

# FRAME WORLD

## Aluminum Structural Framing Components



Introduction .....	2
Section A <b>FastFrames</b> Pre-engineered Components .....	11
<b>FrameQuoter</b> Software .....	23
Section B     5/16" Slot Aluminum Profiles (1.5", 3", 4.5", etc.) .....	26
Section C     5/16" Slot Pictorial Index .....	44
Section C.1   Corner Angle Brackets .....	56
Section C.2   Gusseted Corner Angle Brackets .....	74
Section C.3   Steel Corner Angle Brackets .....	92
Section C.4   Internal and Adjustable Corner Brackets .....	98
Section C.5   Joining Plates .....	128
Section C.6   Floor Mounts, Casters and Adjustable Feet .....	155
Section C.7   Panels, Doors and Hardware .....	182
Section C.8   Hinges, Handles and Latches .....	211
Section C.9   Sliding Components and Bearings .....	244
Section C.11  Stanchions .....	265
Section C.12  Conveyor Components .....	276
Section C.13  Screws, Nuts and Fasteners .....	278
Section C.14  Miscellaneous Components .....	298
Section D     Modular Tooling .....	312
Section E     1/4" Slot Aluminum Profiles (1", 2", 3" etc.) .....	334
Section F     1/4" Slot Pictorial Index .....	341
Section F.1   Corner Angle Brackets .....	351
Section F.2   Gusseted Corner Angle Brackets .....	368
Section F.3   Steel Corner Angle Brackets .....	381
Section F.4   Internal and Adjustable Corner Brackets .....	387
Section F.5   Joining Plates .....	405
Section F.6   Floor Mounts, Casters and Adjustable Feet .....	421
Section F.7   Panels, Doors and Hardware .....	439
Section F.8   Hinges, Handles and Latches .....	450
Section F.9   Sliding Components and Bearings .....	470
Section F.10  Stanchions .....	489
Section F.11  Screws, Nuts and Fasteners .....	497
Section F.12  Miscellaneous Components .....	512
Section G     Aluminum Extrusion Properties and Specifications .....	519
Section H     Other Aluminum Profiles .....	588
Section I     Engineering and Machining Services .....	593
Section J     Applications and Assemblies .....	602
Index .....	607

### **Compare the steps required to complete a project; Aluminum vs. Steel Weldment**

#### **Welded Steel**

1. Planning
2. Purchasing
3. Cutting
4. Layout
5. Welding
6. Straightening
7. Chipping and Sanding
8. Priming and Painting
9. Delivery
10. Maintenance

#### **Aluminum Extrusion**

1. Planning
2. Purchasing
3. Cutting
4. Assembly

### **Welding steel is expensive**

Steel is less costly than aluminum. However, welding steel is an expensive and time consuming process. Welding requires skilled labor and extensive safety precautions to protect personnel from dangerous light and smoke during the welding process. Priming and painting have an environmental impact to be considered and spray booths are a governmental agency concern. The welding is usually done either off-site or in another area of the building, away from the project site. Any changes required later are difficult to make, and often look like a patch or obvious fix.

### **Assembling aluminum extrusions is fast and simple**

Aluminum extrusions have nearly the same tensile strength as mild steel with a much higher strength to weight ratio. A few simple tools and low-tech labor are all that is required for most projects. Aluminum extrusion assembly can easily be done right at the project site, with no special safety equipment required. Construction or design changes or adjustments can be easily and immediately implemented. Even "design as you go" projects have a finished professional look. With great visual aesthetics. The anodized aluminum does not need painting. As soon as the last extrusion is in place, that part of the project is ready for use. The T-slot concept easily accom-

modates later additions or revisions to the project, without looking patched. Finished projects are inherently square, so the need for shimming or leveling is reduced. The nonporous, hollow extrusions are ideal for use as air reservoirs and manifolds for both pressure and valve exhaust collection. Covered extrusion T-slots can be used as conduits for protecting sensor and control wiring.

### **The true cost of steel fixtures includes the cost of welding**

The true cost of steel includes the cost and special needs of the welding process, special equipment, safety concerns, painting and delivery to the site. Once completed, the project is difficult to modify.

### **Aluminum extrusion fixtures are easier than steel fixtures**

Assembly of aluminum extrusions is fast, requires simple tools and labor. It requires no painting, is clean, reusable, easily modified and looks good.

T-Slot technology is widely utilized in industrial structural components.

**FRAME-WORLD** extruded aluminum profiles utilize these longitudinal slots for inserting T-bolts and nuts anywhere along its length to attach connection brackets and accessories.

Threading and machining the ends allows for end joint connections.

No welding or painting is required. All joint connections are screwed together to provide extensive flexibility and allow for conversions, extensions and are separable.

**ALWAYS WEAR SAFETY GLASSES**



## Bulk Profiles

- Standard 8', 12', 16' lengths. (other lengths can be furnished in quantity)
- Available in standard and **SMOOTH-Series** (slotless) designs
- 1/4" and 5/16" slot sizes
- Standard anodized or optional powder coat finishes
- Skidded, wrapped, padded and banded for shipping

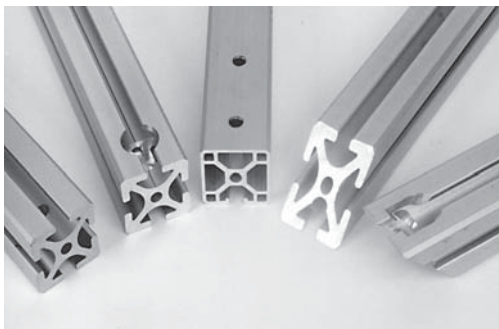

## Cut/Machined Profiles

- Extrusions cut to specified lengths (including miter cuts)
- Custom machining available: drilled holes, tapped holes, counterbores, milling, etc.

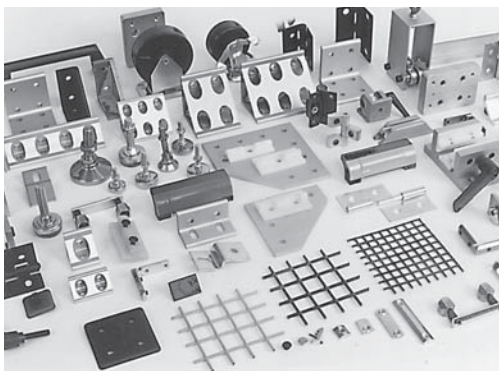

## Components & Accessories

- Wide range of brackets, joining plates, gussets, fasteners, handles, end caps, angles, panel material, bolts, etc.
- Special hinges for ultra-strong doors
- Custom accessories available

**Kits & I.D. Kits**

- **Kits** for multiple frame orders, profiles and accessories are bundled and packaged for each individual frame
- **I.D. Kits** indicate lengths on each extrusion (eliminates profile measuring during assembly)
- Saves you time, money and labor

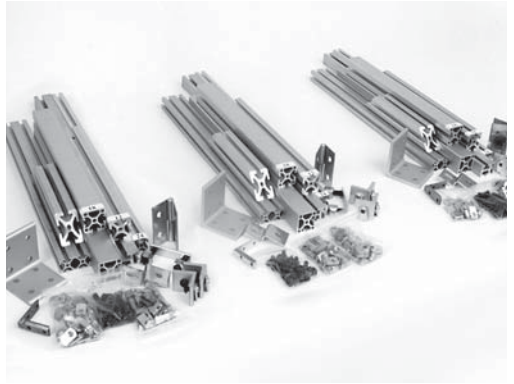
**FastFrames  
Pre-engineered  
Modules and  
Sub Assemblies**

- Includes panels, doors, bases, carts
- All necessary hardware is included
- Available assembled or in kit form
- Greatly simplifies design, ordering and assembly
- Single part number ordering

**Complete Solutions**

- Complete turnkey solutions for machine guards, bases, frames, enclosures, racks, workstations & more
- Tremendous labor (cost) savings
- The simplest solution available

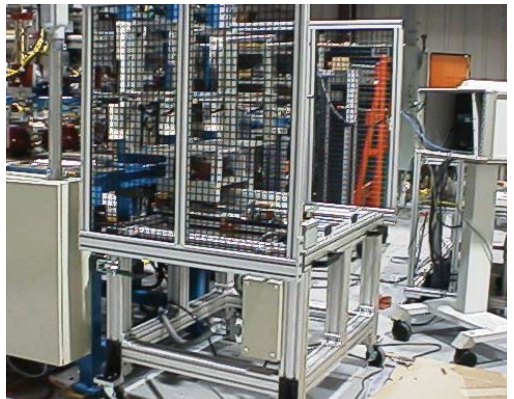

**FRAME-WORLD's** Aluminum Extrusions can be used in any industrial setting, for any purpose!

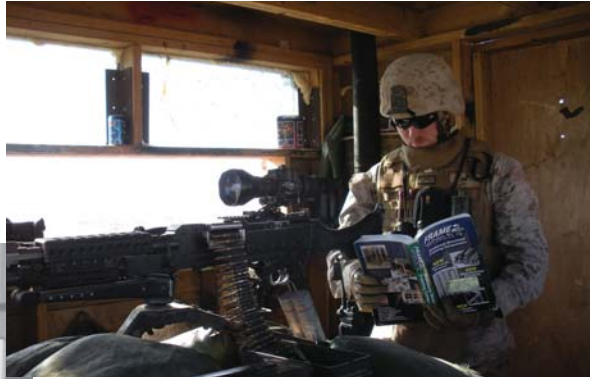

Any setting, Any purpose



Machining & Parts

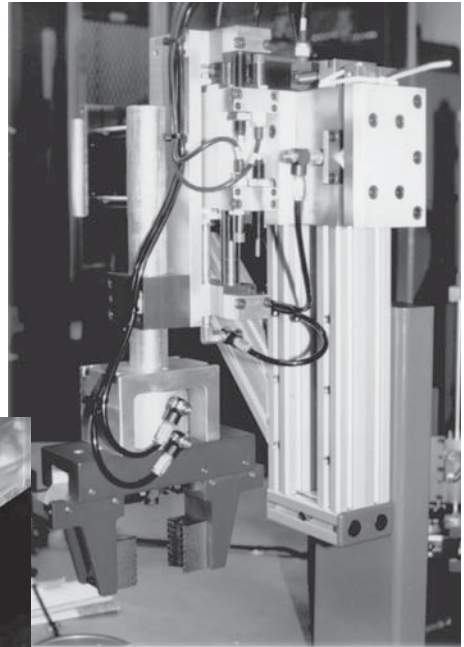

Machine Fixturing

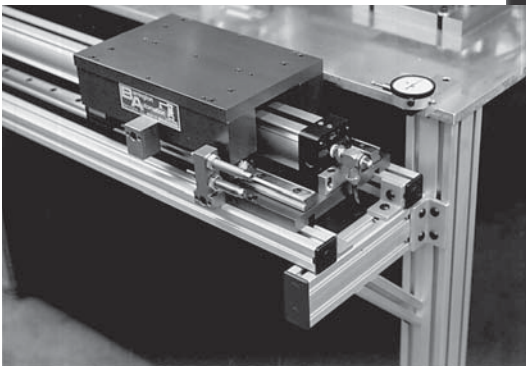

Slide Mount



as Carts



as Racks



Work Stations



Stands





Enclosures



Support brackets



Staging carts



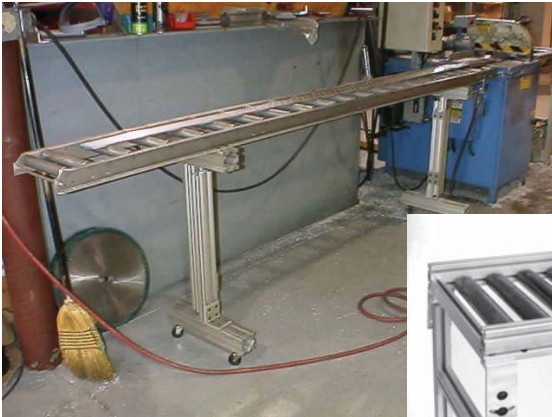

Conveyors



Production Staging



But most importantly, **FRAME-WORLD's** extrusions are a cost effective, low maintenance way to make machine safety guards.

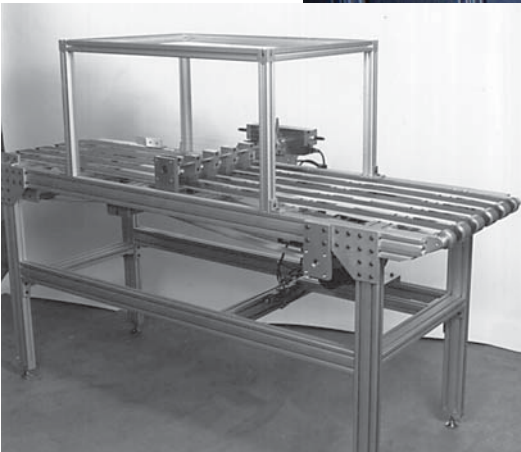
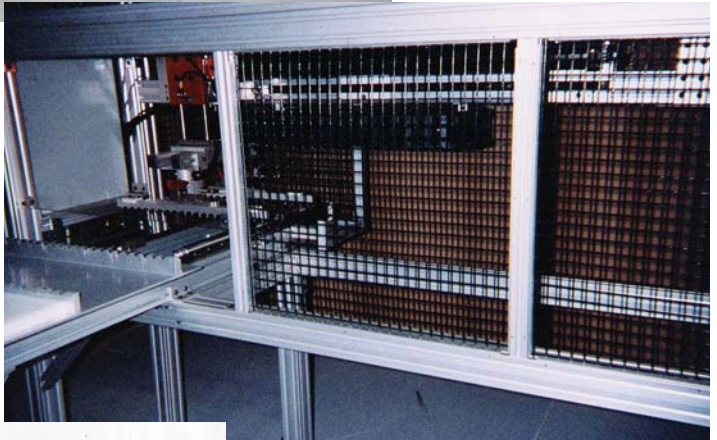

# FastFrames

The fastest and easiest way to develop frames, machine guards, enclosures, carts and conveyor systems.

- Order panels, doors, carts, bases and conveyors with a single part number!
- Each is available pre-assembled or in kit form
- All necessary hardware is included

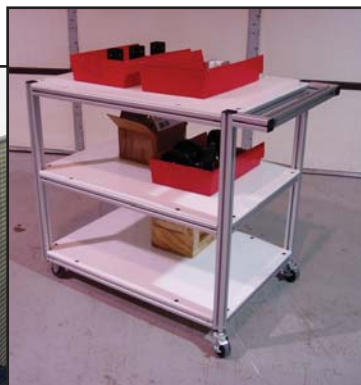

# FastFrames

*Want this?*

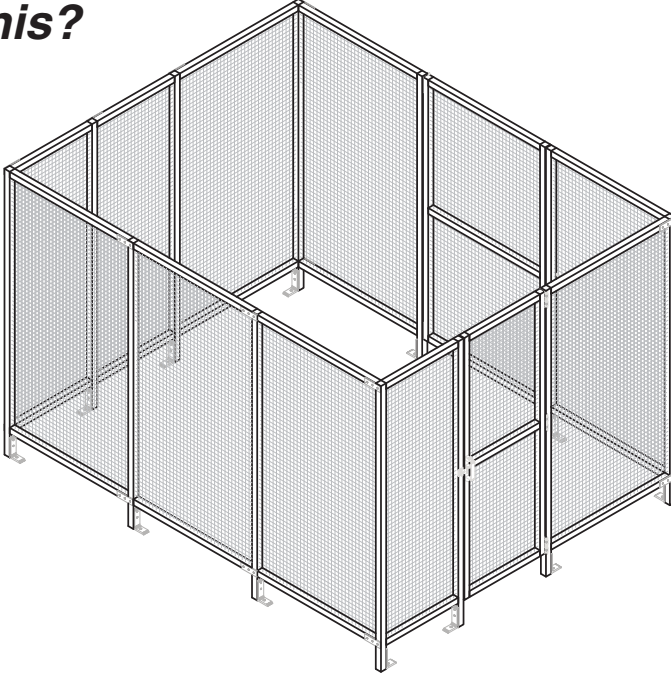

*Order this!*

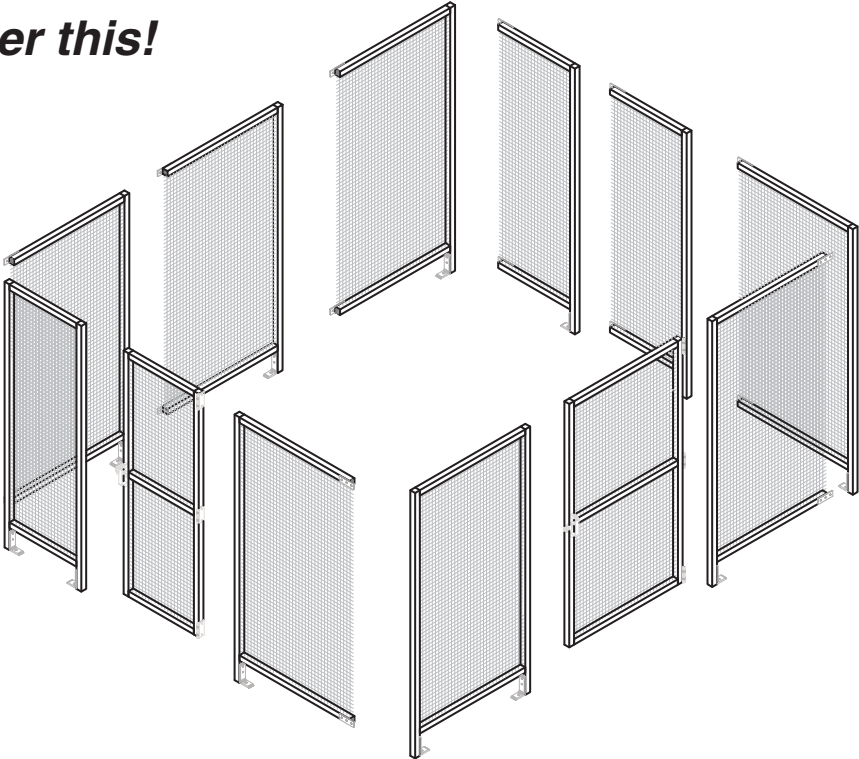

# FastFrames

## Example

Build this entire safety enclosure with only 12 ordered parts, instead of 567 individual components.

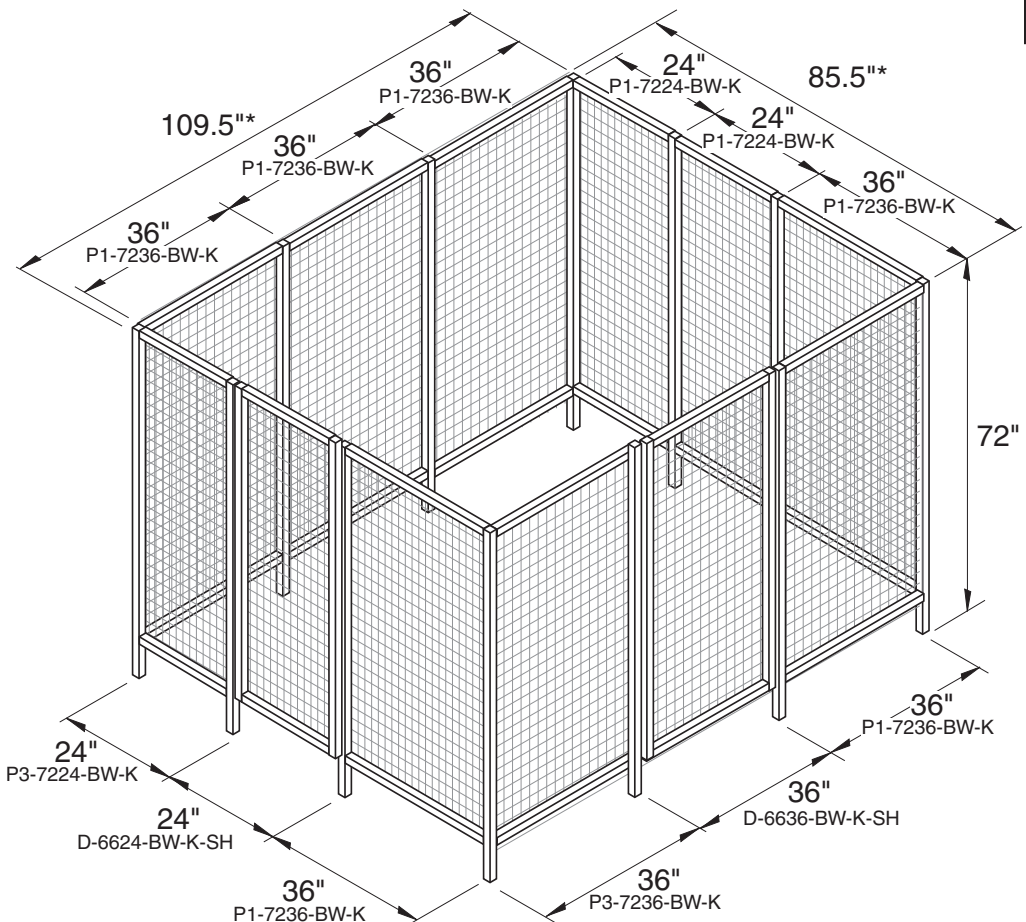

### Bill of Material

(1) D-6636-BW-K-SH	36" Opening Door
(1) D-6624-BW-K-SH	24" Opening Door
(1) P3-7236-BW-K	36" Panel
(1) P3-7224-BW-K	24" Panel
(6) P1-7236-BW-K	36" Panel
(2) P1-7224-BW-K	24" Panel

These dimensions achieved using standard sized panels.

If desired enclosure height, width or depth cannot be achieved with standard sized panels, FRAME-WORLD can add additional panels and adjust the height to do so.

**Please contact your distributor or the factory for custom sizes.**

## Standard Enclosure Panels

- **FastFrames** standard enclosure panels can be purchased pre-assembled or in kit form.
- Frame construction:
  - **Panels**
    - Extrusion frame is EX-9 (page 30) .
    - Corner connectors are EF-29A universal fasteners (page 106).
    - Floor mounting brackets are EB-15AL (page 175).
- Inside panel construction options:
  - 2" x 2" black PVC coated wire mesh is EB-38-2 (page 182)
  - 1" x 1" black PVC coated wire mesh is EB-38-1 (page 182).
  - 1" x 1" yellow PVC coated wire mesh is EB-38-1Y (page 182).
  - 1/4" thick Lexan is EB-160 (page 189).
  - Wire mesh brackets are EB-49B/EB49Y (page 185).
  - Lexan Gasket is EB-40A (page 199).
- Standard panel widths are 18", 24", 30", 36", 48".
- Standard panel heights are 40", 60", 72" & 84".
- Panel to panel connecting brackets and hardware are included.
- Floor anchors are furnished and installed by customer.
- Smooth Series extrusion panels are available.
- **Custom sizes available**



## Standard Enclosure Doors

- **FastFrames** standard doors can be purchased pre-assembled or in kit form.
- Frame construction:
  - **Doors**
    - Extrusion frame is EX-9 (page 30).
    - Corner connectors are EF-29A (page 106).
    - Hinges are EF-70 (page 216).
    - Handle is EF-15B (page 225).
    - Latch is EF-22HD (page 240).
- Inside panel construction options:
  - 2" x 2" black PVC coated wire mesh is EB-38-2 (page 182)
  - 1" x 1" black PVC coated wire mesh is EB-38-1 (page 182).
  - 1" x 1" yellow PVC coated wire mesh is EB-38-1Y (page 182).
  - 1/4" thick Lexan is EB-160 (page 189).
  - Wire mesh brackets are EB-49B/EB49Y (page 185).
  - Lexan Gasket is EB-40A (page 199).
- Standard door widths are 24", 30", 36" & 48" opening.
- Standard door heights are 34", 54", 66", & 78".
- Smooth Series extrusion panels are available.
- **Custom sizes available**

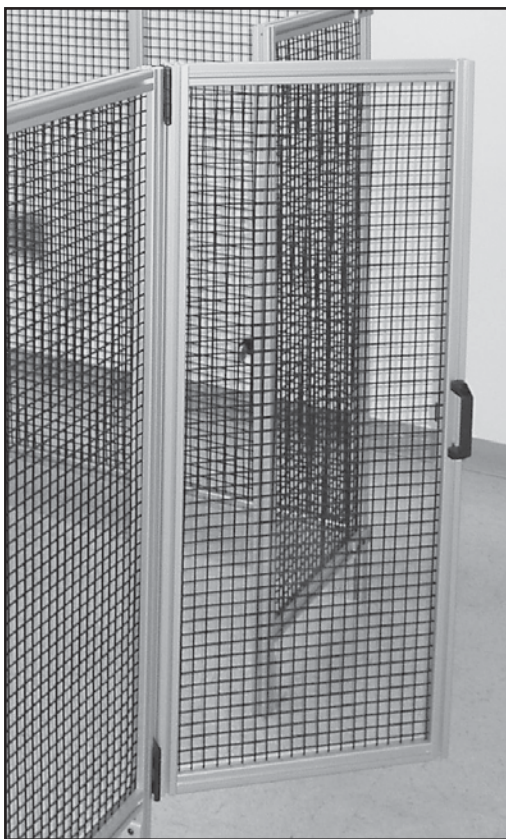



**Standard Enclosure Panels**

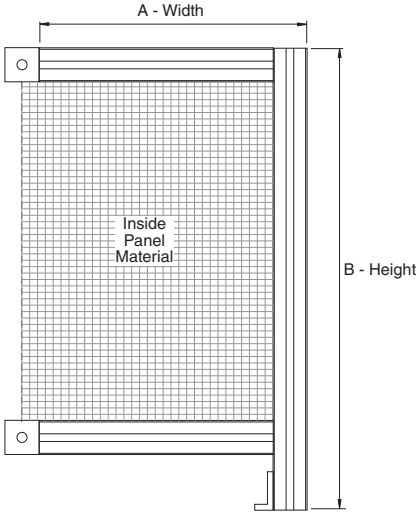

**Standard (1) Leg Panel  
Model P1**

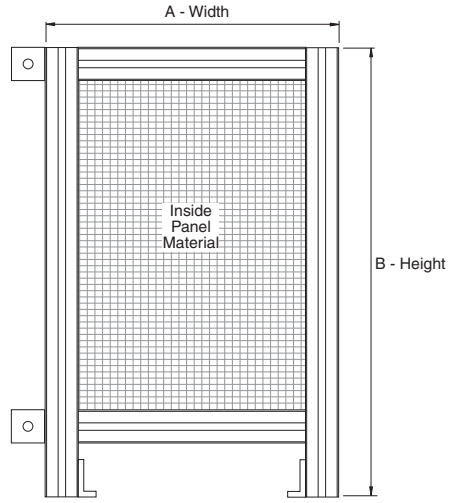

**Standard (2) Leg Panel  
Model P3**

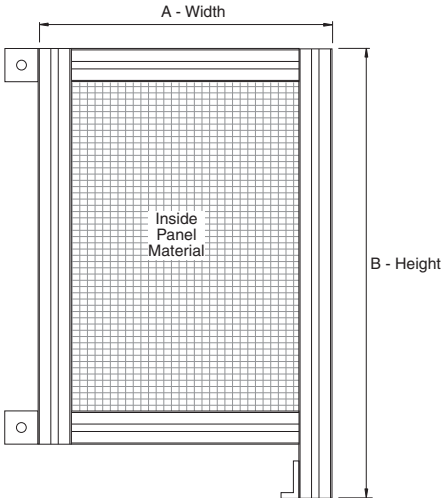

**Standard (1) Leg Panel  
Model P2**

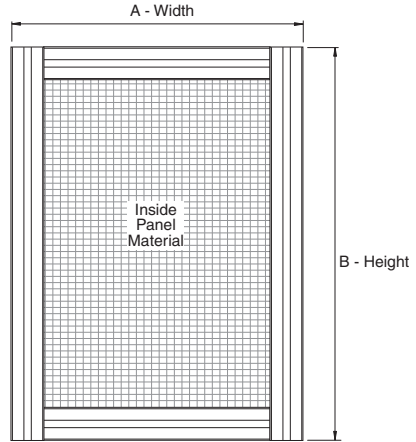

**Standard Basic Panel  
Model P4**

Note: Mounting Hardware Not Included

## Standard Enclosure Panels

- Standard panel heights are 40", 60", 72" & 84".
- Standard panel widths are 18", 24", 30", 36" & 48".
- Smooth Series extrusion panels are available.
- **Custom sizes available** - consult the factory

## Panel Ordering Example

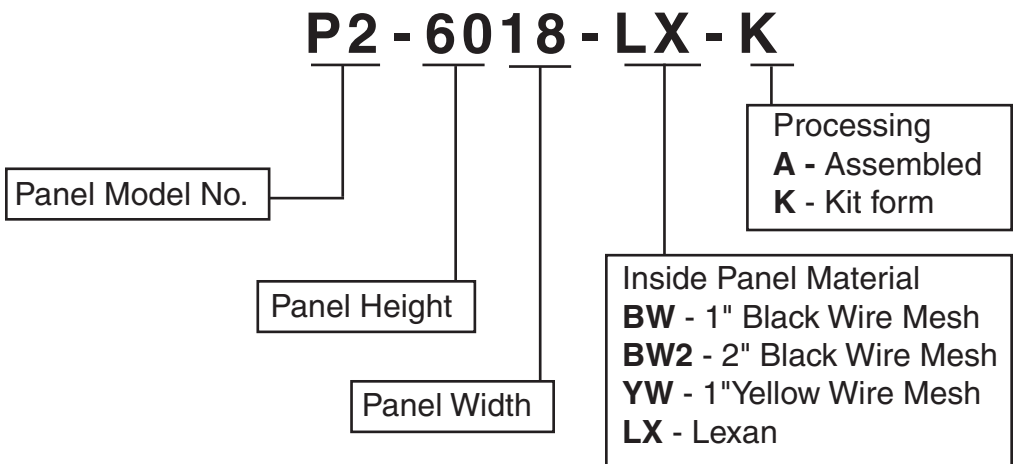

**Standard Enclosure Doors**

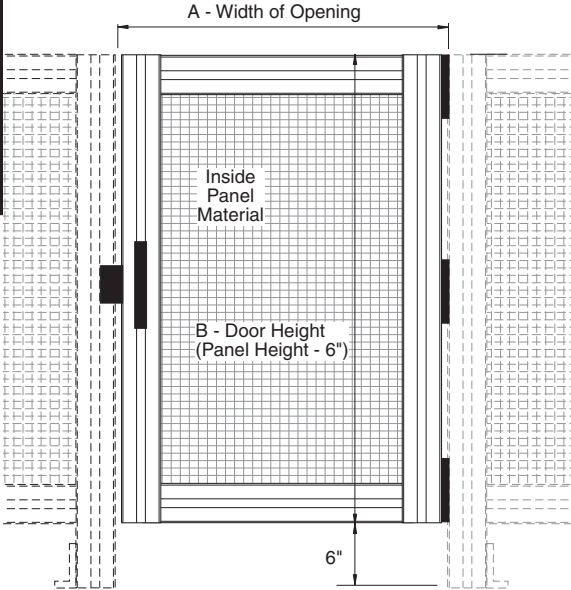

- Standard door heights are 30", 34", 54", 66", & 78".
- Standard door widths are 24", 30", 36" & 48" opening.
- Smooth Series extrusion panels are available.
- **Custom sizes are available** - consult the factory

Note: Part Nos. D-5436, D-6636, & D-7836 have a center extrusion bar.

**Door Ordering Example**

**D- 6624 -BW -A - SH**

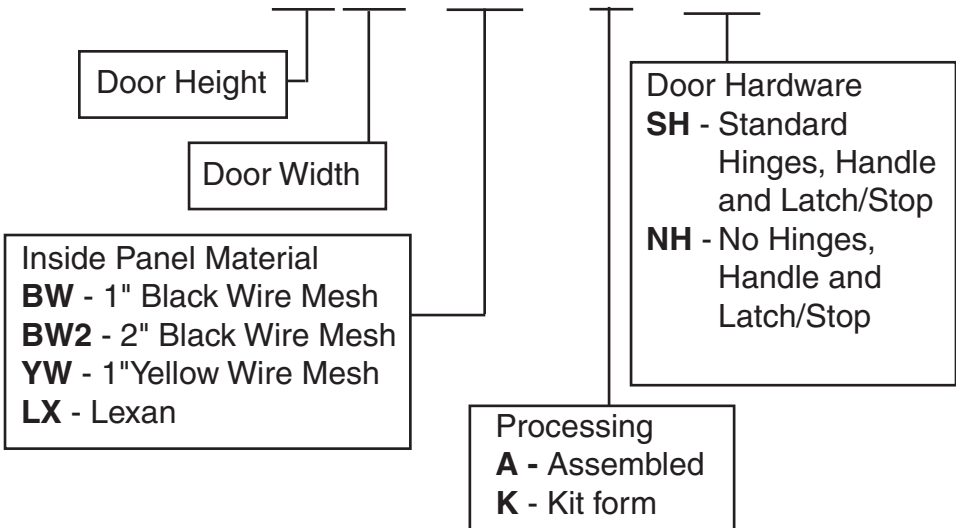

## Standard Material Carts



- 1 1/2" x 1 1/2" extrusion frame
- 3/8" thick high density polyethylene top and shelf material
- 3" diameter casters with brake, 1" wide rubber wheels
- Standard height: 35.0"
- All shelves are height adjustable
- Carts are shipped as kits or assembled
- Shelf sides are achieved by turning shelf upside down
- All hardware included
- 300 pound total capacity
- **Custom sizes available**

**Standard Material Carts**

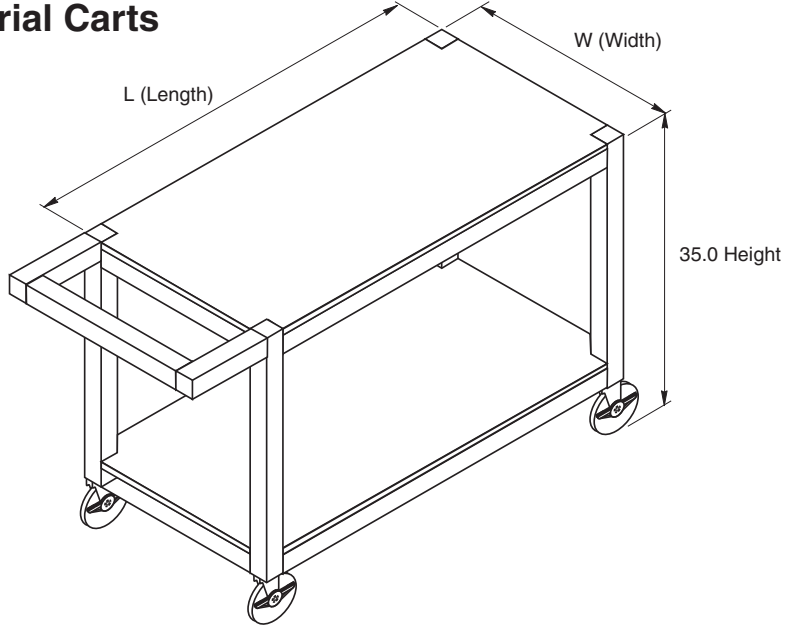

**Model C2 Shelf Cart - (2) shelves**

Length (L)	18"	22"	Width (W)	
			26"	30"
<b>30</b>	C2-3018	C2-3022	C2-3026	C2-3030
<b>36</b>	C2-3618	C2-3622	C2-3626	C2-3630

**Model C3 Shelf Cart- (3) shelves**

Length (L)	18"	22"	Width (W)	
			26"	30"
<b>30</b>	C3-3018	C3-3022	C3-3026	C3-3030
<b>36</b>	C3-3618	C3-3622	C3-3626	C3-3630

**Material Cart Ordering Example**

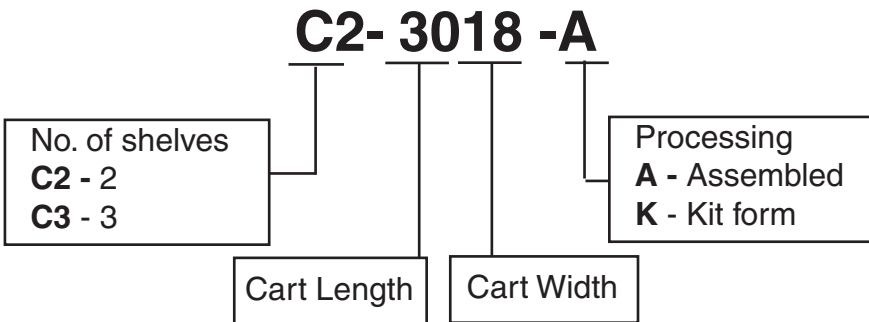

**Custom sizes are available - consult the factory**

## Standard Bases and Tables

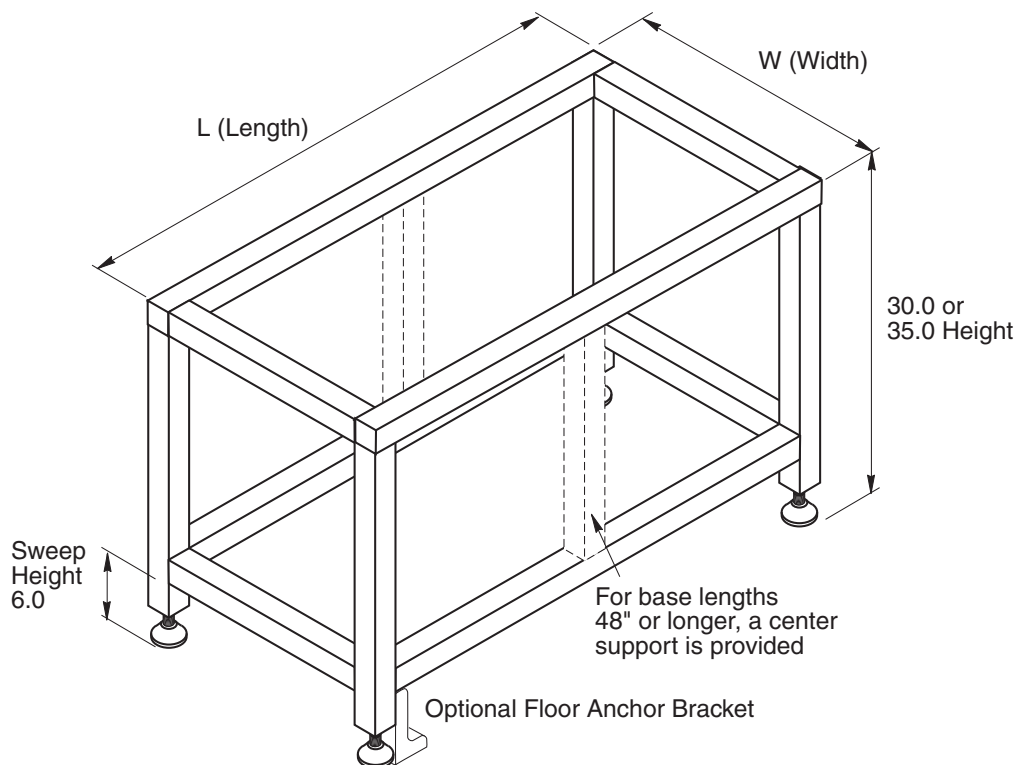

- Available in kit form or assembled
- Includes adjustable legs
- Floor Anchor Brackets available on request
- Choice of Light, Standard or Heavy Duty
- Standard Heights of 30" or 35"
- Tops and enclosure panels available on request - consult factory
- Sweep height = 6.00"
- Light Duty is EX-1
- Standard Duty is EX-2
- Heavy Duty is EX-3
- **Custom sizes available**

**Model L Light Duty**

Length (L)	Width (W)			Max Load
	24"	30"	36"	
36"	L-3624	L-3630	L-3636	400
48"	L-4824	L-4830	L-4836	360
60"	L-6024	L-6030	L-6036	300
72"	L-7224	L-7230	L-7236	240

**Model S Standard Duty**

Length (L)	Width (W)			Max Load
	24"	30"	36"	
36"	S-3624	S-3630	S-3636	2800
48"	S-4824	S-4830	S-4836	2000
60"	S-6024	S-6030	S-6036	1720
72"	S-7224	S-7230	S-7236	1480

**Model H Heavy Duty**

Length (L)	Width (W)			Max Load
	24"	30"	36"	
36"	H-3624	H-3630	H-3636	5400
48"	H-4824	H-4830	H-4836	3800
60"	H-6024	H-6030	H-6036	3300
72"	H-7224	H-7230	H-7236	3000

**Standard Base Ordering Example**

**S - 4824 - 30 - A - FA**

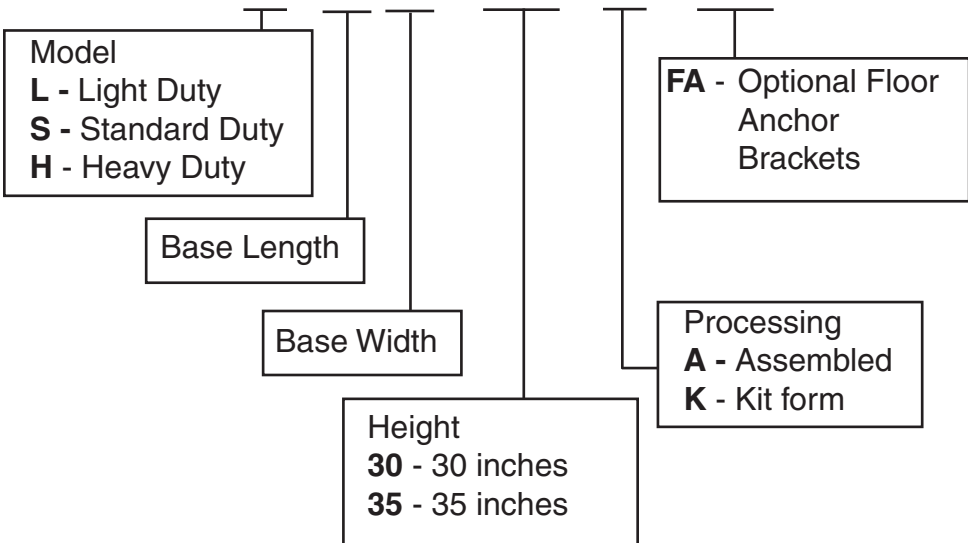

**Custom sizes are available - consult the factory**

# FrameQuoter

Aluminum Extrusion Design Software

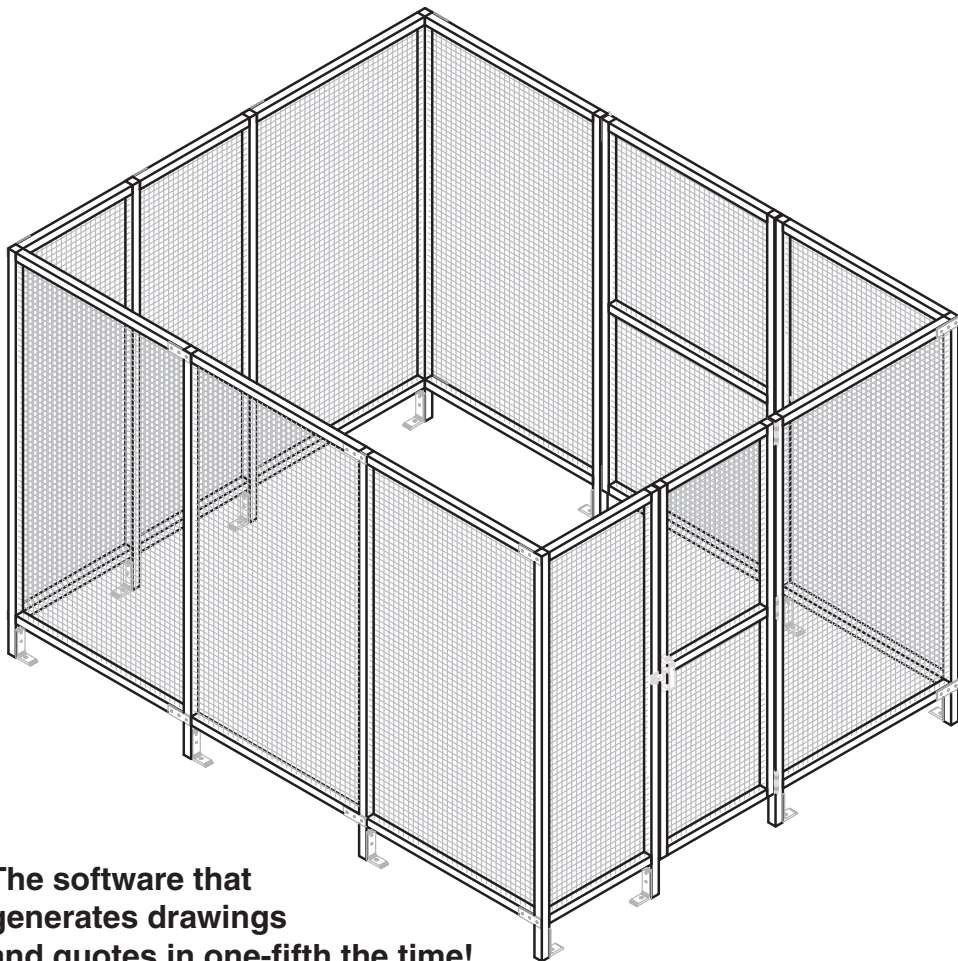

**The software that  
generates drawings  
and quotes in one-fifth the time!**

**FrameQuoter** is the most advanced and easiest to use aluminum profile design and quote software available today! It will enable you to quickly and easily produce professional looking 3D drawings with bills of materials and quotations that are detailed and accurate, 5 times faster than doing them by hand! **FrameQuoter** will increase your efficiency and confidence.



## You Can Design This Machine Guard In 2 ½ Hours...

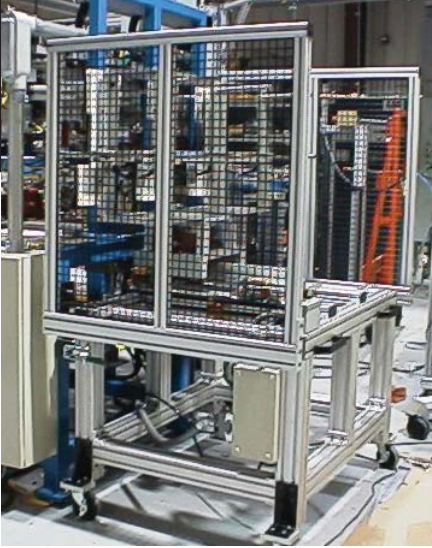

Or In Just 14 Minutes.

### Try Our **FREE Design Software And See For Yourself.**

Designing a machine guard, frame or enclosure can be a very time-consuming and frustrating experience. Any errors, omissions or miscalculations can result in a structure which is cumbersome to use, doesn't fit the application, or is totally useless. Our **FrameQuoter** design software eliminates these problems, and helps you create the ideal structure, quickly and easily.

## **FrameQuoter Software Decreases Design Time By Up To 92% And Eliminates Errors, Omissions and Hassles**

Actual field studies have shown that our **FrameQuoter** design software will drastically reduce the amount of time required to design a machine guard or frame. And because we have simplified and/or automated many functions ("snap-in-place" corner brackets, automatically includes necessary machining, nuts, bolts, etc.), you will have less errors, mistakes or hassles. You can be assured that every structure you design will be right the first time, every time.

## **Easy To Learn, Easy To Use**

This was the #1 design criteria. With even a basic knowledge of AutoCAD, you will quickly master **FrameQuoter**. We have shortened and/or eliminated many of the steps necessary with other design software packages by using simple icons and drop-down menus. A complete Bill of Materials is also only one mouse click away.

## **Incredible Life-Like Full-Color Graphics**

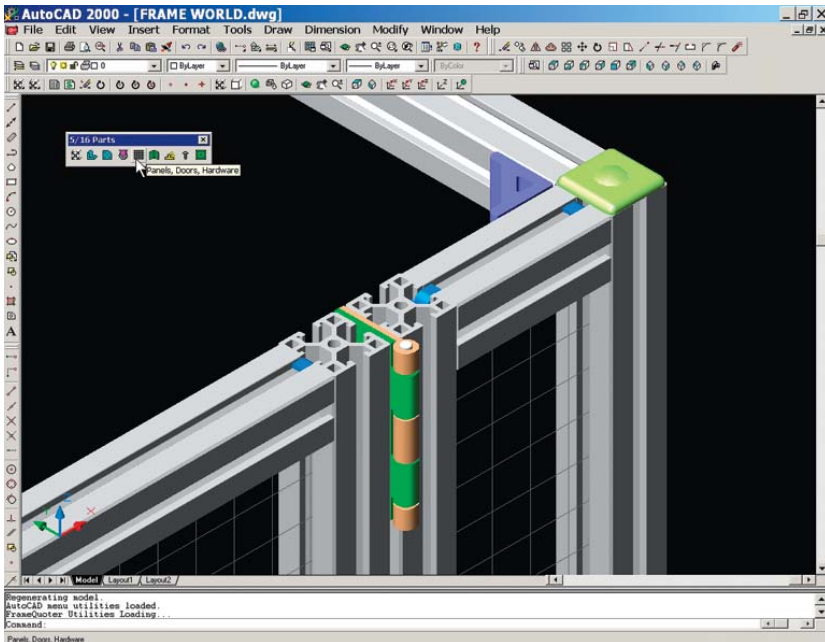

**FrameQuoter** is the only design software package that enables you to develop wireframe, hidden and shaded drawings in 2D and 3D, in both simplified and detailed views. The “Detailed-Shaded” view shows you the final assembly with incredible detail & clarity:

## The Possibilities Are Endless

If you can build it with aluminum extrusions, you can design it with **FrameQuoter**. People have designed wall racks, workstations, tables, machine bases, machining stations, clean room enclosures, tool fixtures, and much more. Unlike other design packages, **FrameQuoter** enables you to employ every FRAME-WORLD extrusion, and every bracket and accessory into any drawing. You can even add non-FRAME-WORLD parts to the Bill of Materials!

## Solidworks Library Available

FRAME-WORLD offers a full Solidworks (TM) parasolid library of all our products. Additional CAD formats of our part library, including .igs, .dwg, and .dxf, are also available. All CAD files are available for download at [www.frame-world.com](http://www.frame-world.com)

# Metric Sizes for FRAME-WORLD T-slot Extrusions and Accessories



Part No.	Extrusion Size		Fastener Size	
	Inches	Nearest Metric	Inches	Metric
EX-1	1.5" x 1.5"	38 x 38 mm	5/16-18	m8
EX-2	1.5" x 3"	38 x 76 mm	5/16-18	m8
EX-3	3" x 3"	76 x 76 mm	5/16-18	m8
EX-6	1.5" x 1.5"	38 x 38 mm	5/16-18	m8
EX-7	1.5" corner	38 x 38 mm	5/16-18	m8
EX-8	1.5" round	38 x 38 mm	5/16-18	m8
EX-9	1.5" x 1.5"	38 x 38 mm	5/16-18	m8
EX-11	1" x 1"	25 x 25 mm	1/4-20	m6
EX-12	1" x 2"	25 x 50 mm	1/4-20	m6
EX-13	1" x 3"	25 x 76 mm	1/4-20	m6
EX-22	2" x 2"	50 x 50 mm	1/4-20	m6
EX-24	2.0" x 4.0"	50 x 100 mm	1/4-20	m6
EX-26	1.5" x 4.5"	38 x 174 mm	5/16-18	m8
EX-36	3" x 6"	76 x 152 mm	5/16-18	m8
EX-37	3.0" x 3.0"	76 x 76 mm	5/16-18	m8
EX-45HD	4.5" x 4.5"	114 x 114 mm	5/16-18	m8
EX-52	1" x 1.5"	25 x 38 mm	5/16-18	m8
EX-54	1" x 1.5"	25 x 38 mm	5/16-18	m8
EX-60	2.38" x 2.38"	60 x 60 mm	5/16-18	m8
EX-61	1.5" x 1.5"	38 x 38 mm	5/16-18	m8
EX-63	1.5" x 1.5"	38 x 38 mm	5/16-18	m8
EX-64	1.5" x 1.5"	38 x 38 mm	5/16-18	m8
EX-65	1.5" x 1.5"	38 x 38 mm	5/16-18	m8
EX-66	1.5" x 3"	38 x 76 mm	5/16-18	m8
EX-67	1.5" x 3"	38 x 76 mm	5/16-18	m8
EX-68	1.5" x 3"	38 x 76 mm	5/16-18	m8
EX-69	1.5" x 3"	38 x 76 mm	5/16-18	m8
EX-70	1" x 1"	25 x 25 mm	1/4-20	m6
EX-71	1" x 1"	25 x 25 mm	1/4-20	m6
EX-72	1" x 1"	25 x 25 mm	1/4-20	m6
EX-73	1" x 1"	25 x 25 mm	1/4-20	m6
EX-82	1.5" angle	38 x 38 mm	5/16-18	m8
EX-83	1.5" x 3.0"	38 x 76 mm	5/16-18	m8

5/16" SLOTS



**EX-1**  
1.5" x 1.5"

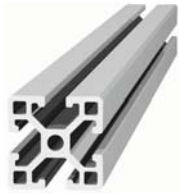

**EX-6**  
1.5" x 1.5"



**EX-9**  
1.5" x 1.5"

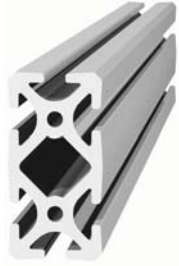

**EX-2**  
1.5" x 3.0"

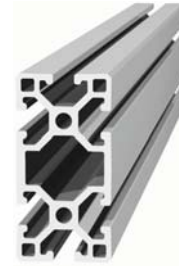

**EX-67**  
1.5" x 3.0"

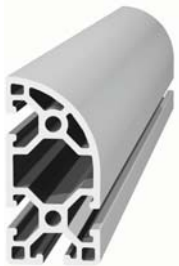

**EX-83**  
1.5" x 3.0"



**EX-26**  
1.5" x 4.5"



**EX-3**  
3.0" x 3.0"

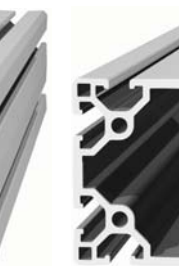

**EX-37**  
3.0" x 3.0"

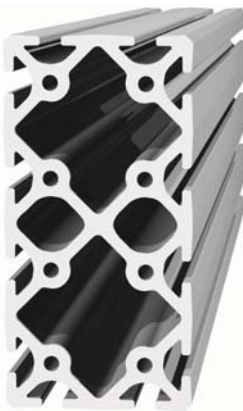

**EX-36**  
3.0" x 6.0"



**EX-45HD**  
4.5" x 4.5"

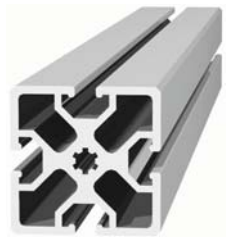

**EX-60**  
2.38" x 2.38"

**5/16" SLOTS**

**SMOOTH-Series**

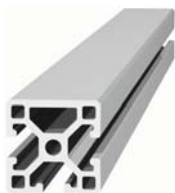

**EX-63**  
1.5" x 1.5"

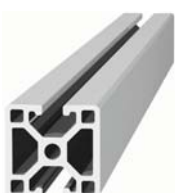

**EX-64**  
1.5" x 1.5"

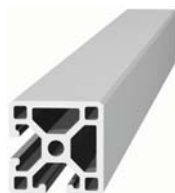

**EX-65**  
1.5" x 1.5"

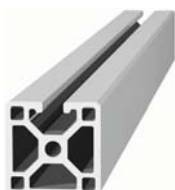

**EX-61**  
1.5" x 1.5"



**EX-7**  
1.5" x 1.5"



**EX-8**  
1.5" x 1.5"



**EX-68**  
1.5" x 3.0"



**EX-66**  
1.5" x 3.0"

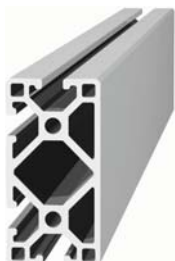

**EX-69**  
1.5" x 3.0"



**EX-52**  
1.0" x 1.5"



**EX-54**  
1.0" x 1.5"



**EX-82**  
1.5" x 1.5"  
45 deg.

5/16" SLOTS

**EX-1**

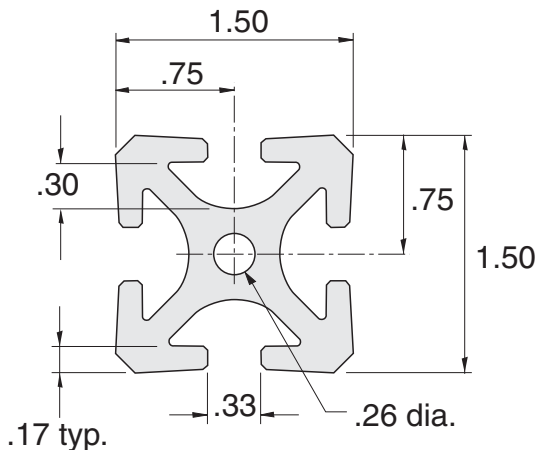

- Finish = Clear anodized
- Material = 6105-T5 Aluminum
- Est. Area = 1.164 Sq. In.
- Weight/ft = 1.4522 lbs.
- 96", 144.25", 192.63" Lengths standard.

**Section Properties:**

Moment of Intertia in <sup>4</sup>	.242
Section modulus in <sup>3</sup>	.323

5/16" SLOTS

**EX-6**

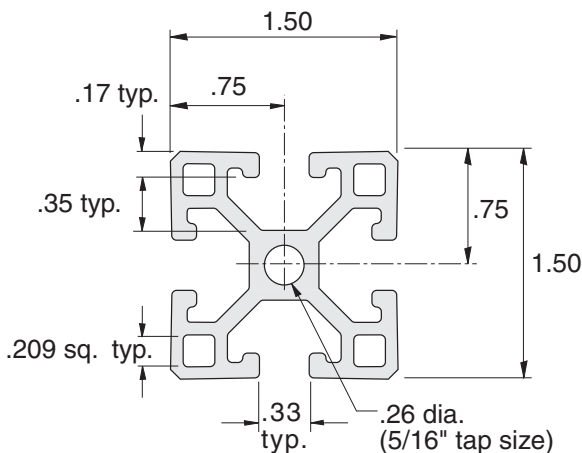

- Finish = Clear anodized
- Material = 6105-T5 Aluminum
- Est. Area = .878 Sq. In.
- Weight/ft = 1.029 lbs.
- 96", 144.25", 192.63" Lengths standard.

**Section Properties:**

Moment of Intertia in <sup>4</sup>	.199
Section modulus in <sup>3</sup>	.265

**EX-9**

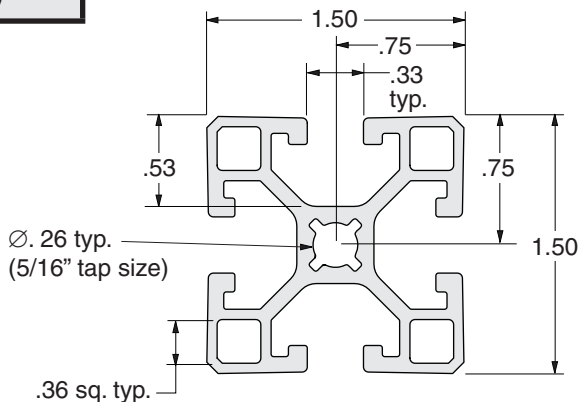

- 5/16" Slot Size
- Weight/Ft = .85 lbs.
- Est. Area = .73 Sq. In.
- Finish = Clear Anodized
- Material = 6105-T5 Aluminum
- 96", 192.63" Standard Lengths

**EX-2**

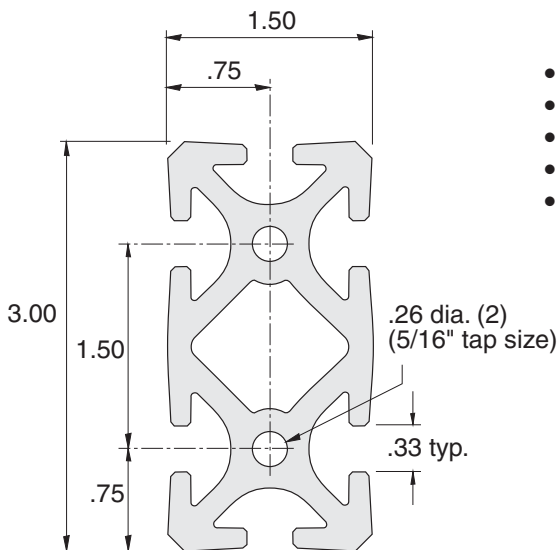

- Finish = Clear anodized
- Material = 6105-T5 Aluminum
- Est. Area = 2.051 Sq. In.
- Weight/ft = 2.471 lbs.
- 96", 144.25", 192.63" Lengths standard.

**Section Properties:**

Moment of Intertia in <sup>4</sup>	1.76	.481
Section modulus in <sup>3</sup>	1.173	.641



**EX-67**

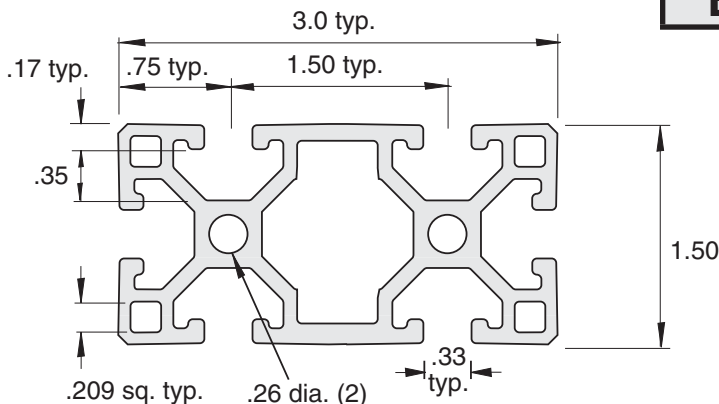

- Finish = Clear anodized
- Material = 6105-T5 Aluminum
- Est. Area = 1.569 Sq. In.

- Weight/ft = 1.845 lbs
- 96", 144.25", 192.63" Lengths standard.

**Section Properties:**

Moment of Intertia in <sup>4</sup>	1.376	0.387
Section modulus in <sup>3</sup>	0.917	0.516



**5/16" SLOTS**

**EX-3**

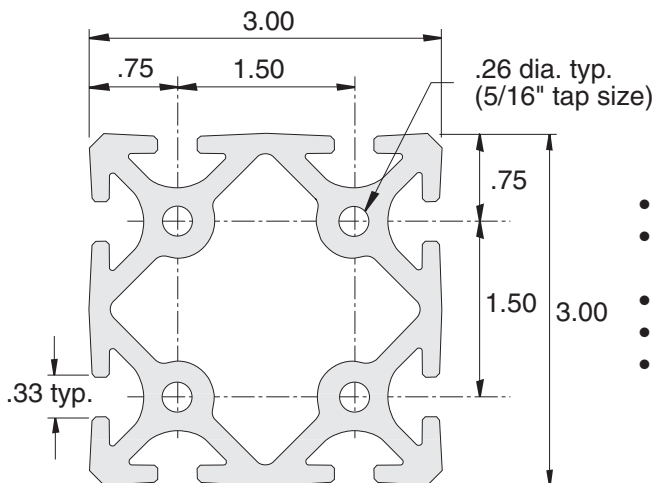

- Finish = Clear anodized
- Material = 6105-T5 Aluminum
- Est. Area = 3.188 Sq. In.
- Weight/ft = 4.037 lbs.
- 96", 144.25", 192.63" Lengths standard.

**Section Properties:**

Moment of Intertia in <sup>4</sup>	3.26
Section modulus in <sup>3</sup>	2.173





**EX-37**

**5/16" SLOTS**

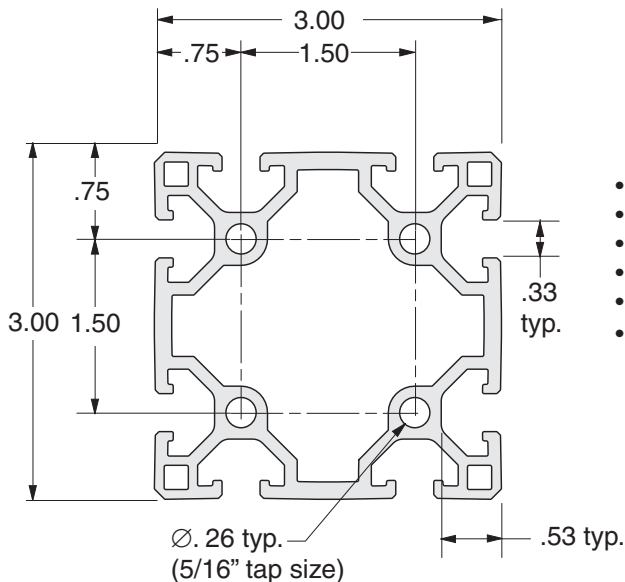



- 5/16" Slot Size
- Weight/Ft = 2.81 lbs.
- Est. Area = 2.35 Sq. In.
- Finish = Clear Anodized
- Material = 6105-T5 Aluminum
- 96", 192.63" Standard Lengths

**EX-26**

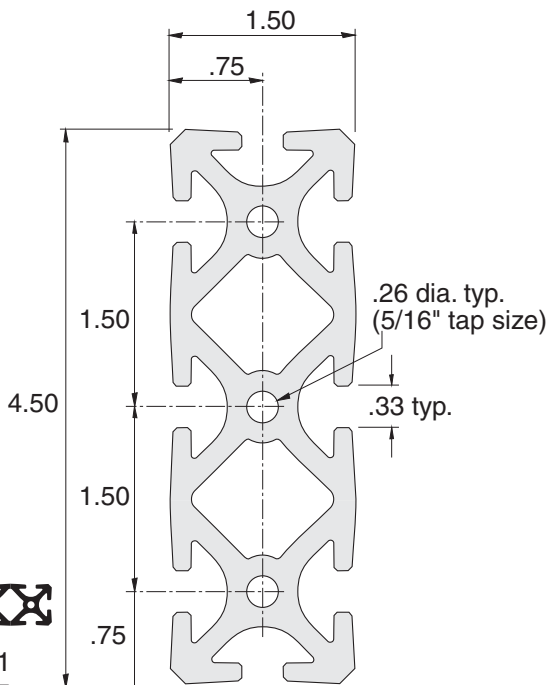
- Finish = Clear anodized
- Material = 6105-T5 Aluminum
- Est. Area = 3.02 Sq. In.
- Weight/ft = 3.552 lbs.
- 96", 192.63" Lengths standard.



<b>Section Properties:</b>		
	Moment of Intertia in <sup>4</sup>	5.6781
Section modulus in <sup>3</sup>	2.5236	.9215

## EX-36

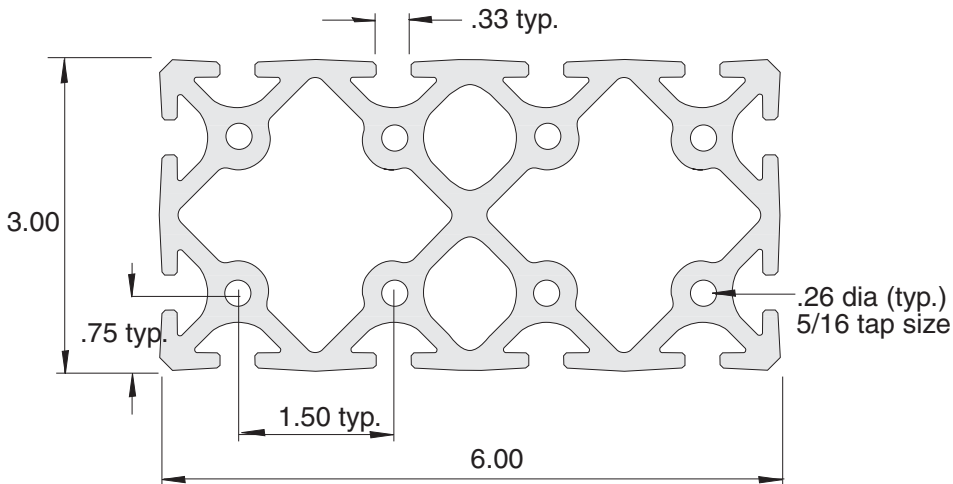

- Finish = Clear anodized
- Material = 6063-T6 Aluminum
- Est. Area = 5.924 Sq. In.
- Weight/ft = 6.967 lbs.
- 96", 192.63"
- Lengths standard.

### Section Properties:

Moment of Intertia in <sup>4</sup>	22.05	6.41
Section modulus in <sup>3</sup>	7.35	4.28



5/16" SLOTS

## EX-60

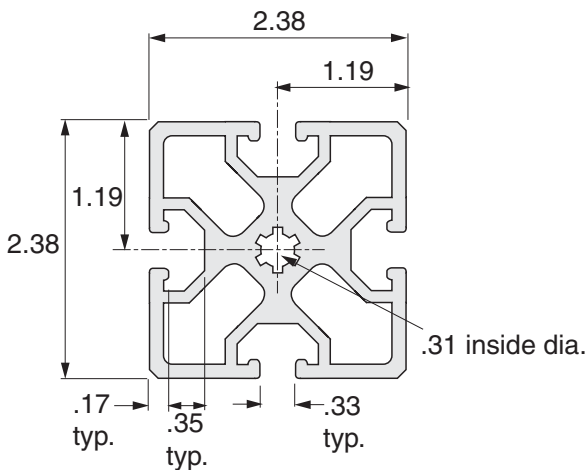

- Finish = Clear anodized
- Material = 6105-T6 Aluminum
- Est. Area = 2.041 Sq. In.
- Weight/ft = 2.400 lbs
- 96", 192.63" Lengths standard.

### Section Properties:

Moment of Intertia in <sup>4</sup>	1.021
Section modulus in <sup>3</sup>	0.860



## EX-83

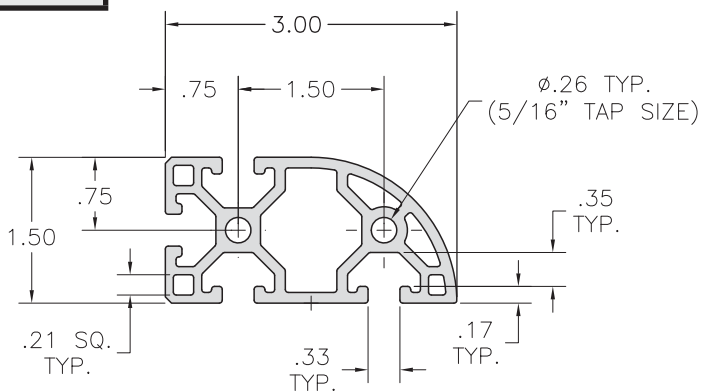

5/16" SLOTS

Finish: Clear Anodize  
 Material: 6105-T6 Aluminum  
 Est. Area: 1.464 Sq In.  
 Wt./Ft: 1.722 lbs.  
 Std. Length: 144"

Section Properties:  
 Moment of Inertia in<sup>4</sup>  
 Section Modulus in<sup>3</sup>



1.229  
 0.779



0.338  
 0.424

## EX-45HD

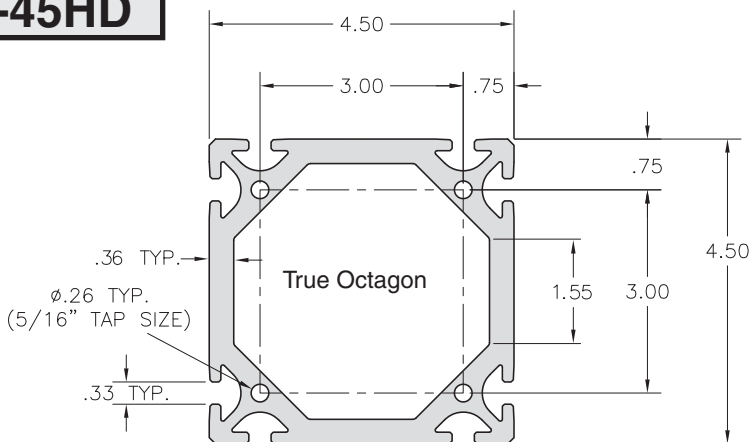

Finish: Mill Finish  
 Material: 6105-T6 Aluminum  
 Est. Area: 6.330 Sq In.  
 Wt./Ft: 7.445 lbs.  
 Std. Length: 192.63"  
 Special cut charge required for non-standard length (EM-1-EX45)

Section Properties:  
 Moment of Inertia in<sup>4</sup>  
 Section Modulus in<sup>3</sup>



16.4  
 6.56

## SMOOTH-Series Aluminum Profiles Give You *Less*:

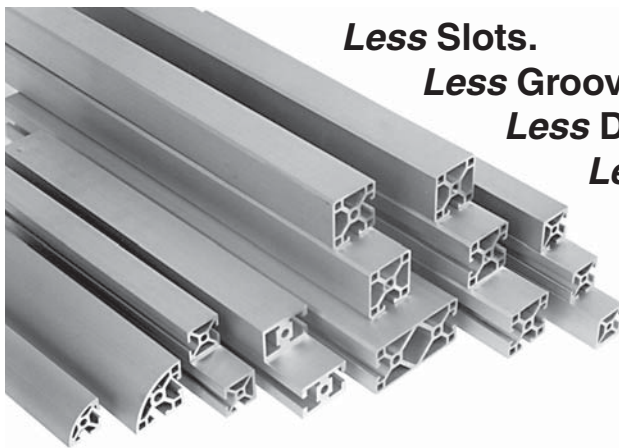

***Less Slots.***

***Less Grooves.***

***Less Dirt.***

***Less Germs.***

***Less Maintenance.***

***And Less  
Headaches.***

***For Less Money.***

5/16" SLOTS

Aluminum extrusions are the ideal choice when building protective machine guards, machine frames or enclosures for any industrial environment. Unfortunately, traditional aluminum profiles are also a breeding ground for dirt, oil, grease, mold, mildew, germs and bacteria to accumulate and grow. They have up to 22 places to hide (3 exposed T-slots and 19 grooves, per length of extrusion). This makes maintenance and cleaning difficult, ongoing and very expensive. Health and safety issues are a huge concern.

How do you stop the maintenance nightmare? Our **SMOOTH-Series** profiles eliminate all the dirt catching grooves, and provide you only the number of T-slots required for your assembly. The **SMOOTH surfaces** wipe clean easily, without the toothbrush-scrubbing, knuckle-breaking cleaning required for exposed slots and grooves. Dirt, germs and other contaminants don't have a place to hide.

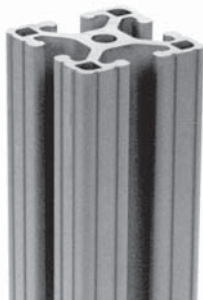

Traditional Aluminum  
Extrusion  
4 Slots & 16 Grooves



FRAME-WORLD's  
**SMOOTH-Series**  
1 Slot, NO Grooves

5/16" SLOTS

Suitable for clean rooms, tough enough for steel mills  
*SMOOTH-Series* profiles are ideal for any manufacturing facility where dirt, germs, mold, mildew and bacteria build-up can result in critical health and safety issues:

- Clean Rooms
- Food & Beverage
- Packaging
- Pharmaceutical
- Medical and Biotechnology
- Electronics

The same *SMOOTH-Series* profiles can also withstand harsh industrial environments where dirt, oil, grease and chemicals are a daily fact of life.

***In stock and available for immediate delivery.***

This is the only full range of truly smooth profiles in U.S. fractional sizes on the market. All models and versions are available for same-day shipment. For your convenience, *SMOOTH-Series* profiles are also available as kits, engineered sub-assemblies, or as complete turnkey solutions (machine guards, frames, enclosures, etc.).

**EX-61**

**SMOOTH-Series**

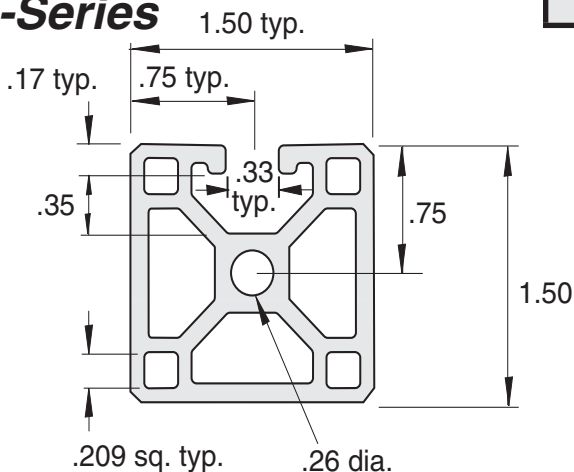

- Finish = Clear anodized
- Material = 6105-T5 Aluminum
- Est. Area = .866 Sq. In.
- Weight/ft = 1.018 lbs
- 96", 144.25", 192.63" Lengths standard.

**Section Properties:**

Moment of Intertia in <sup>4</sup>	0.200	0.210
Section modulus in <sup>3</sup>	0.267	0.276



**5/16" SLOTS**

**SMOOTH-Series**

**EX-63**

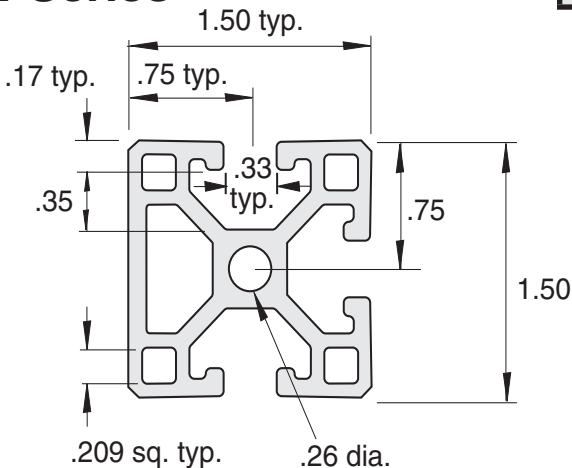

- Finish = Clear anodized
- Material = 6105-T5 Aluminum
- Est. Area = .833 Sq. In.
- Weight/ft = .980 lbs.
- 96", 144.25", 192.63" Lengths standard.

**Section Properties:**

Moment of Intertia in <sup>4</sup>	0.195	0.203
Section modulus in <sup>3</sup>	0.260	0.267



**EX-64**

**SMOOTH-Series**

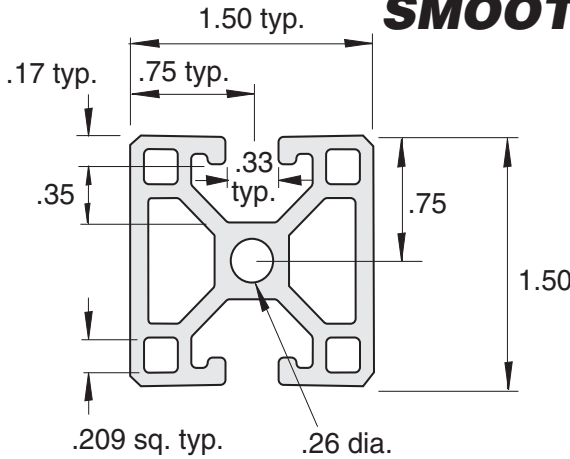

5/16" SLOTS

- Finish = Clear anodized
- Material = 6105-T5 Aluminum
- Est. Area = .849 Sq. In.
- Weight/ft = .998 lbs
- 96", 144.25", 192.63" Lengths standard.



**Section Properties:**

Moment of Inertia in <sup>4</sup>	0.190	0.210
Section modulus in <sup>3</sup>	0.253	0.280

**EX-65**

**SMOOTH-Series**

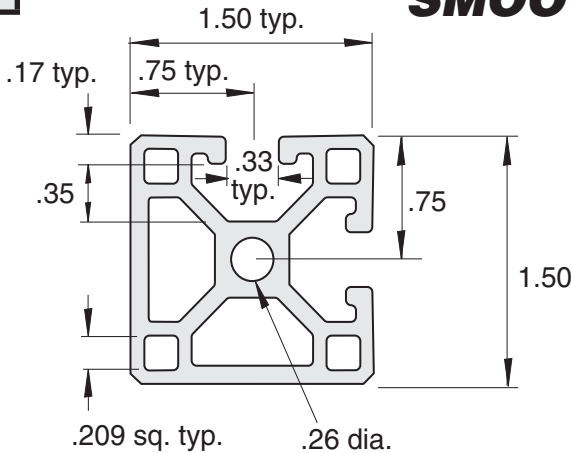

- Finish = Clear anodized
- Material = 6105-T5 Aluminum
- Est. Area = .849 Sq. In.
- Weight/ft = .998 lbs.
- 96", 144.25", 192.63" Lengths standard.



**Section Properties:**

Moment of Inertia in <sup>4</sup>	0.200
Section modulus in <sup>3</sup>	0.267

**SMOOTH-Series**

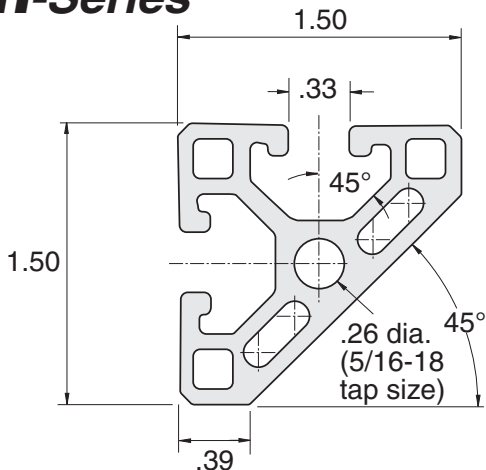

- Finish = Clear anodized
- Material = 6105-T5 Aluminum
- Est. Area = .729 Sq. In.
- Weight/ft = .854 lbs.
- 96", 192.63" Lengths standard.

**Section Properties:**

Moment of Intertia in <sup>4</sup>	.137
Section modulus in <sup>3</sup>	.195

**5/16" SLOTS**

**SMOOTH-Series**

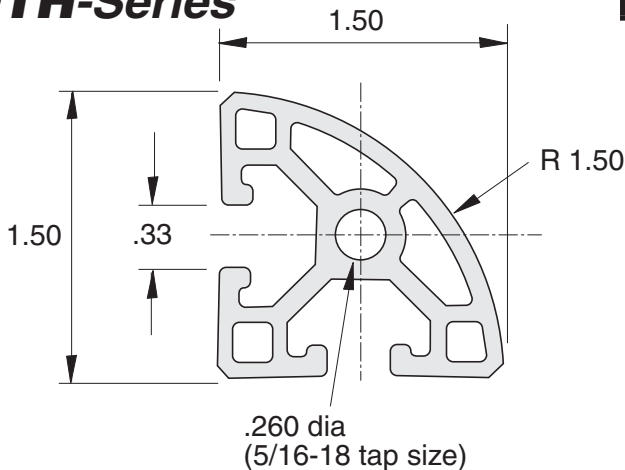

- Finish = Clear anodized
- Material = 6105-T6 Aluminum
- Est. Area = .803 Sq. In.
- Weight/ft = .945 lbs.
- 96", 192.63" Lengths standard.

**Section Properties:**

Moment of Intertia in <sup>4</sup>	.156
Section modulus in <sup>3</sup>	.188



**EX-68**

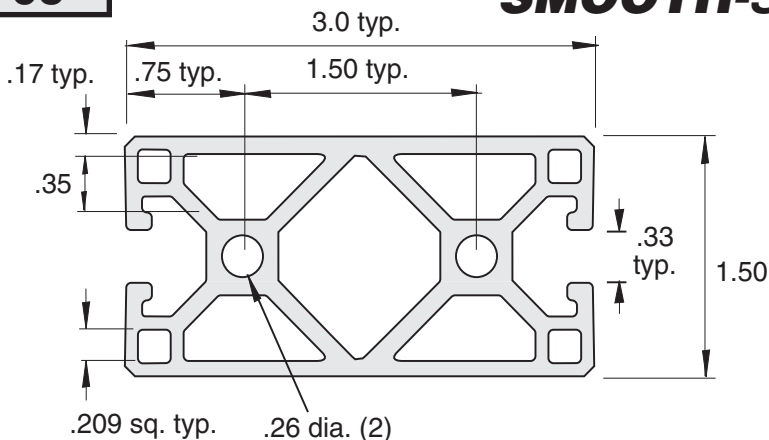

5/16" SLOTS

- Finish = Clear anodized
- Material = 6105-T5 Aluminum
- Est. Area = 1.599 Sq. In.
- Weight/ft = 1.880 lbs.
- 96", 144.25", 192.63"  
Lengths standard.

**Section Properties:**

Moment of Inertia in <sup>4</sup>	1.385	0.401
Section modulus in <sup>3</sup>	0.923	0.535



**EX-66**

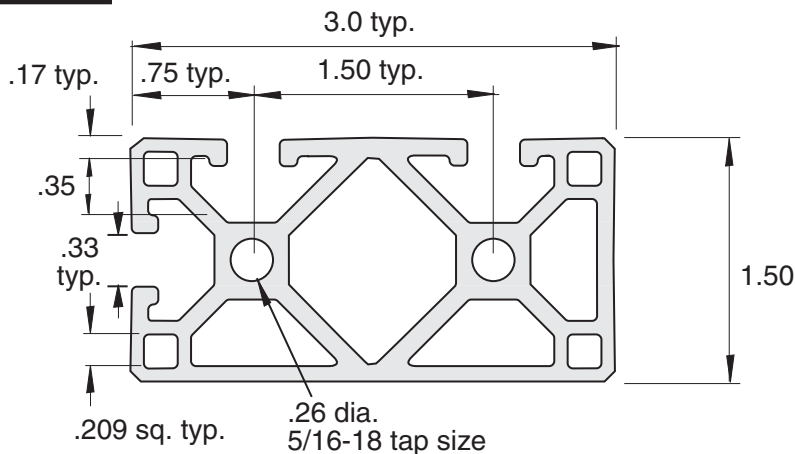

- Finish = Clear anodized
- Material = 6105-T5 Aluminum
- Est. Area = 1.599 Sq. In.
- Weight/ft = 1.880 lbs.
- 96", 144.25", 192.63"  
Lengths standard.

**Section Properties:**

Moment of Inertia in <sup>4</sup>	1.385	0.401
Section modulus in <sup>3</sup>	0.923	0.535



**EX-69**

**SMOOTH-Series**

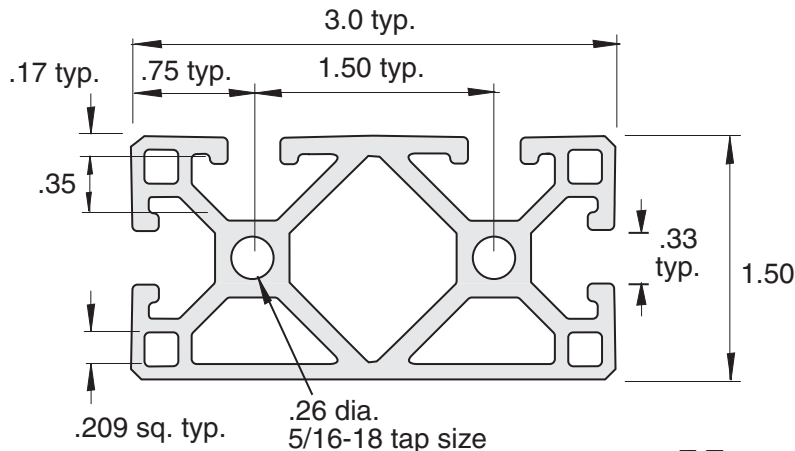

- Finish = Clear anodized
- Material = 6105-T5 Aluminum
- Est. Area = 1.599 Sq. In.
- Weight/ft = 1.880 lbs.
- 96", 144.25", 192.63" Lengths standard.

**Section Properties:**

Moment of Intertia in <sup>4</sup>	1.385	0.401
Section modulus in <sup>3</sup>	0.923	0.535



**5/16" SLOTS**

**SMOOTH-Series**

**EX-52**

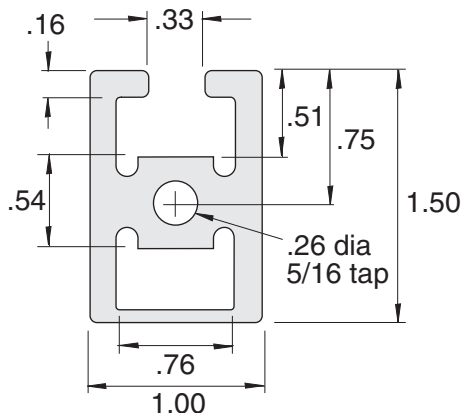

- Finish = Clear anodized
- Material = 6105-T5 Aluminum
- Est. Area = .818 Sq. In.
- Weight/ft = .954 lbs.
- 96", 144.25", 192.63" Lengths standard.

**Section Properties:**

Moment of Intertia in <sup>4</sup>	0.417	0.099
Section modulus in <sup>3</sup>	0.549	0.198



**EX-54**

**SMOOTH-Series**

**5/16" SLOTS**

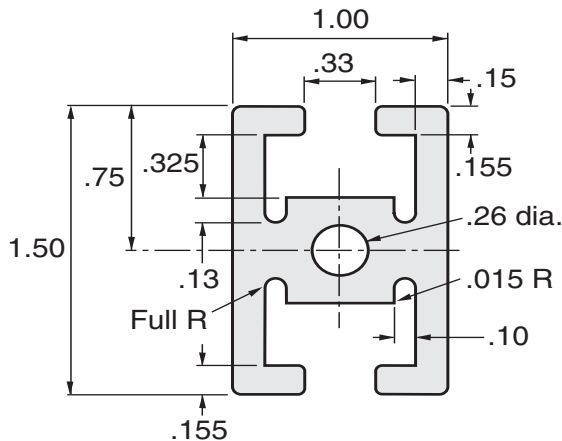

- Finish = Clear anodized
- Material = 6105-T5 Aluminum
- Est. Area = .840 Sq. In.
- Weight/ft = 1.008 lbs.
- 96", 144.25", 192.63" Lengths standard.



**Section Properties:**

Moment of Intertia in <sup>4</sup>	0.142	0.100
Section modulus in <sup>3</sup>	0.189	0.200

**EX-82**

**SMOOTH-Series**

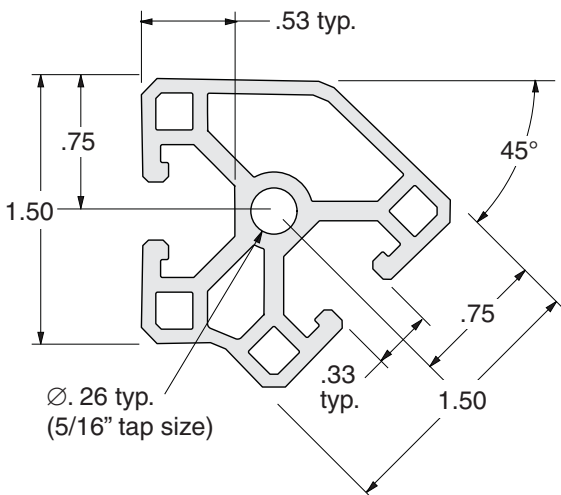

- 5/16" Slot Size
- Weight/Ft = 1.02 lbs.
- Est. Area = .85 Sq. In.
- Finish = Clear Anodized
- Material = 6105-T5 Aluminum
- 96", 192.63" Standard Lengths

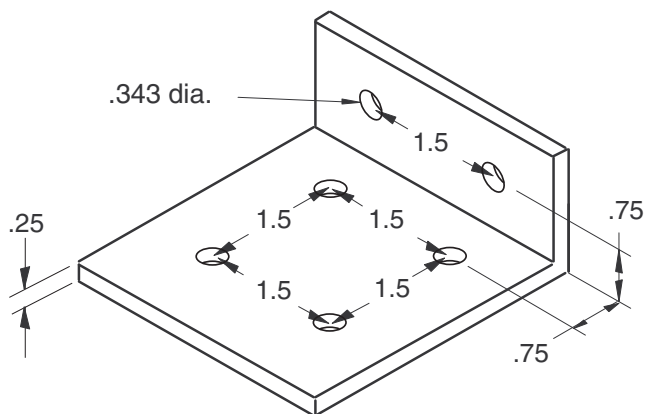

Mounting and connecting brackets have clearance holes for 5/16" (8 mm) dia. connecting screws which are all on .75" and 1.5" centers.

FRAME-WORLD designed fastener brackets, extrusions, hardware and accessories provide an unlimited system for structural design and assembly.

Note: Mounting brackets and plates are made of clear anodized aluminum unless otherwise specified

Recommended torque for 5/16-18 or m8 fasteners is 15 to 20 ft lbs

**Section C.1**  
**Corner Angle**  
**Brackets**

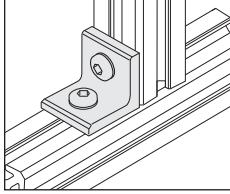

page 56

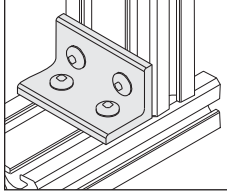

page 57

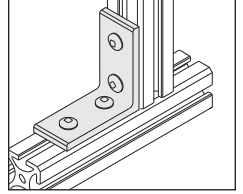

page 58

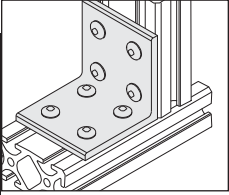

page 59

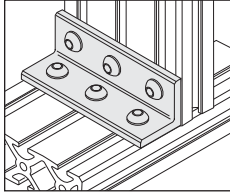

page 60

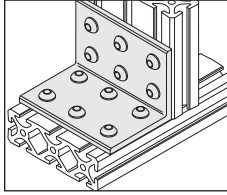

page 61

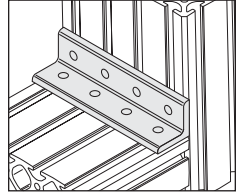

page 62

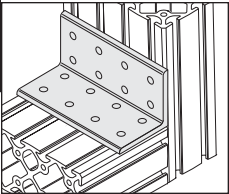

page 63

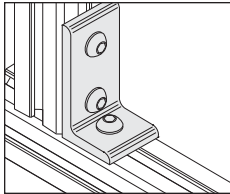

page 64

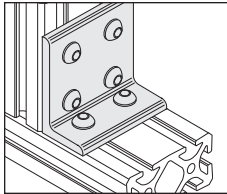

page 65

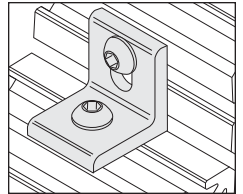

page 66

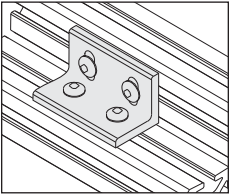

page 67

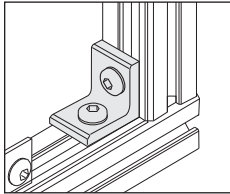

page 68

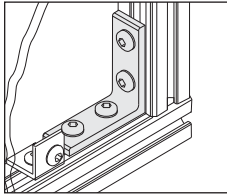

page 69

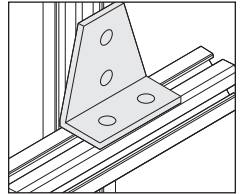

page 70

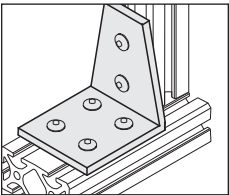

page 71

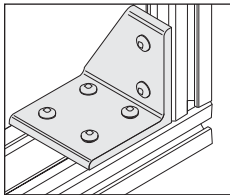

page 72

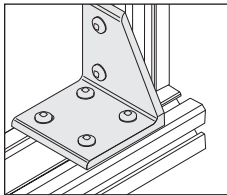

page 73

**Section C.2**  
**Gusseted**  
**Corner Angle**  
**Brackets**

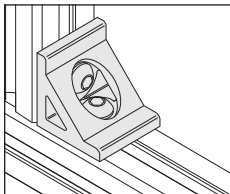

page 74

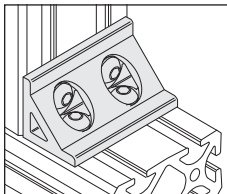

page 75

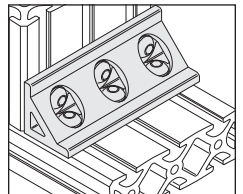

page 76

5/16" SLOTS

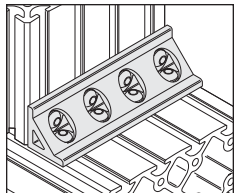

page 77

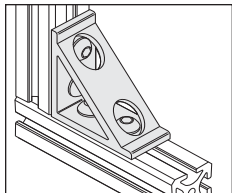

page 78

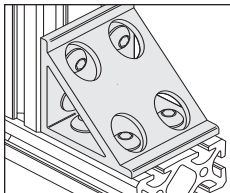

page 79

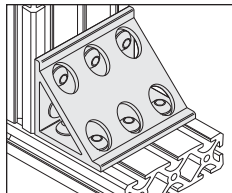

page 80

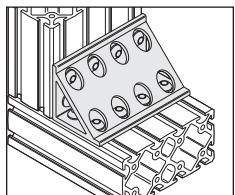

page 81

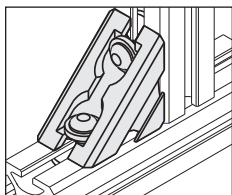

page 82

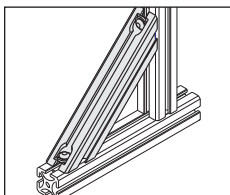

page 83

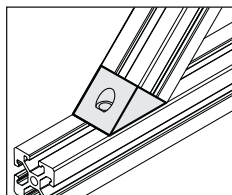

page 84

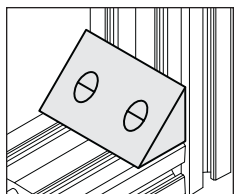

page 85

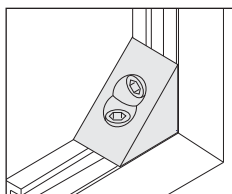

page 86

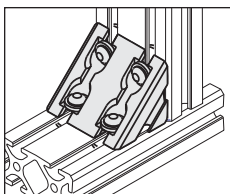

page 87

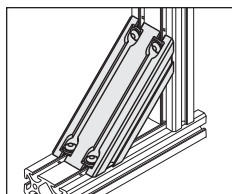

page 88

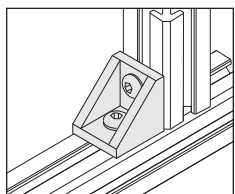

page 89

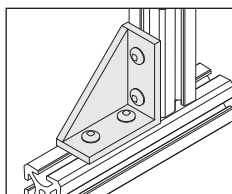

page 90

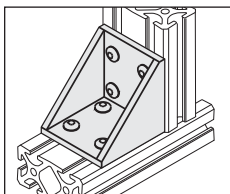

page 91

## Section C.3

### Steel Corner Angle Brackets

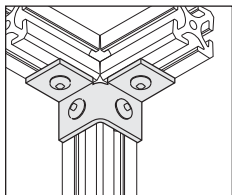

page 94

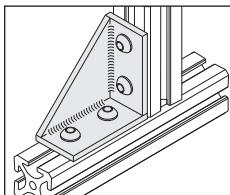

page 95

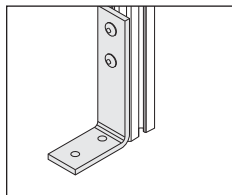

page 96

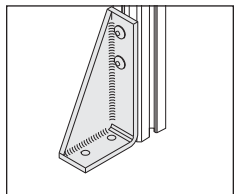

page 97

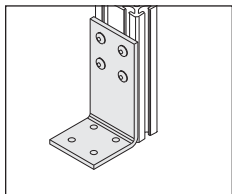

page 98

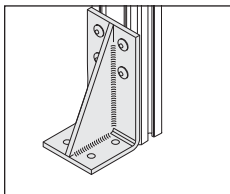

page 99

5/16" SLOTS

## Section C.4

### Internal & Adjustable Corner Brackets

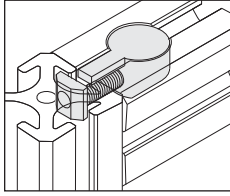

page 98

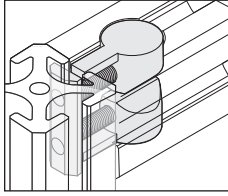

page 99

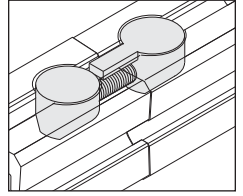

page 100

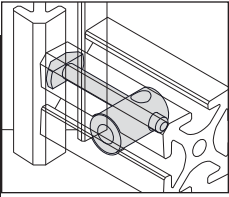

page 101

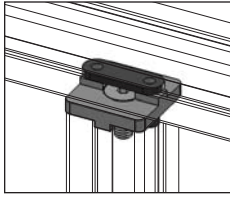

page 102

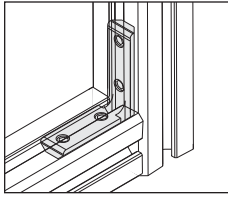

page 103

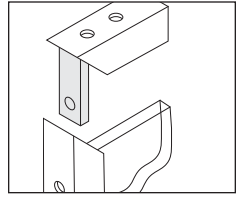

page 104

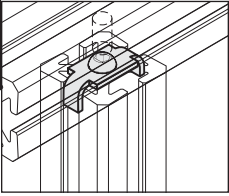

page 105

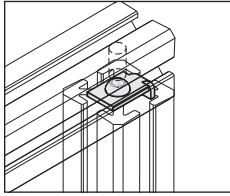

page 106

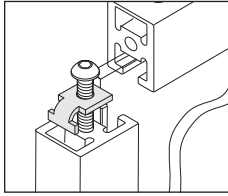

page 107

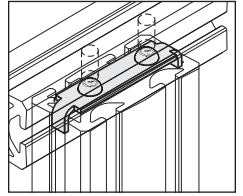

page 108

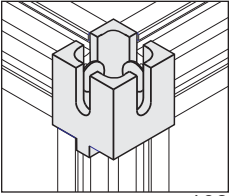

page 109

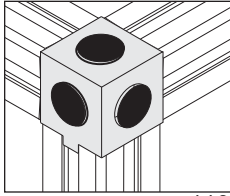

page 110

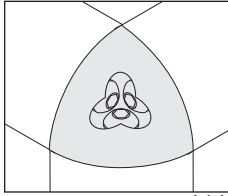

page 111

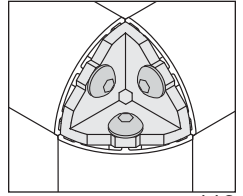

page 112

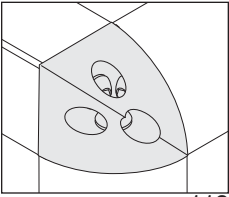

page 113

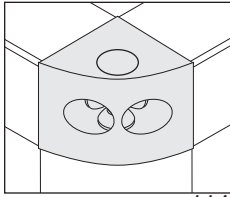

page 114

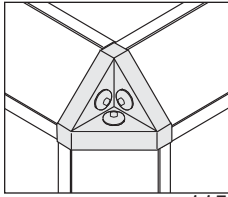

page 115

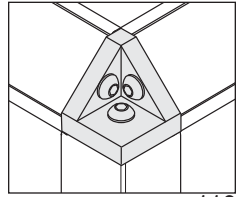

page 116

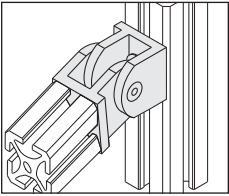

page 117

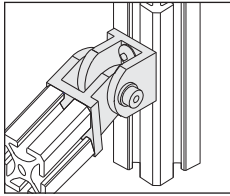

page 118

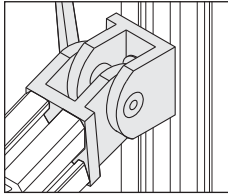

page 119

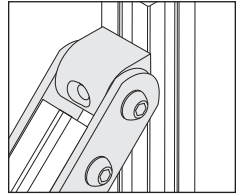

page 120

5/16" SLOTS

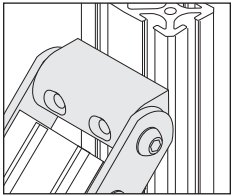

page 121

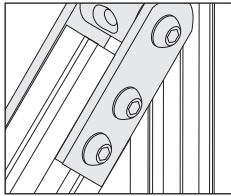

page 122

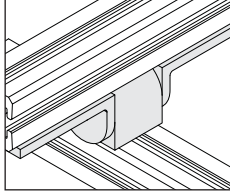

page 123

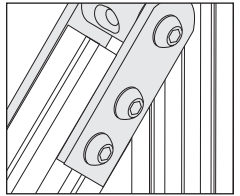

page 124

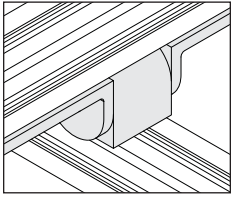

page 125

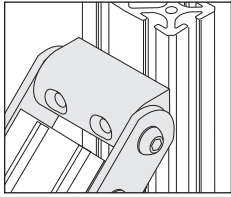

page 126

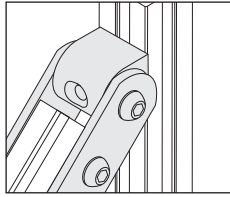

page 127

## Section C.5

### Joining Plates

5/16" SLOTS

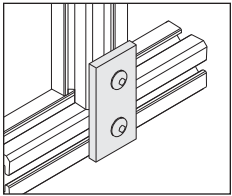

page 128

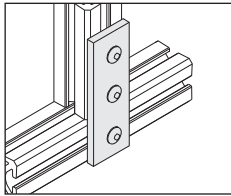

page 129

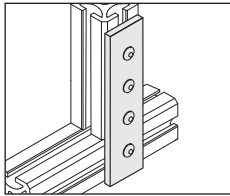

page 130

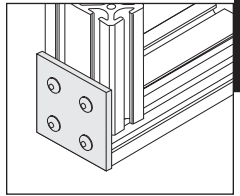

page 131

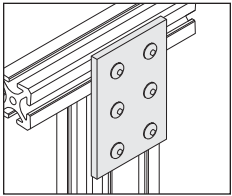

page 132

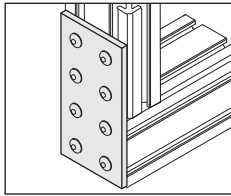

page 133

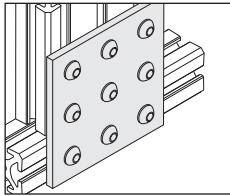

page 134

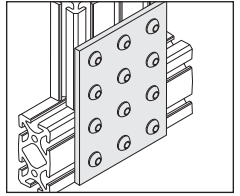

page 135

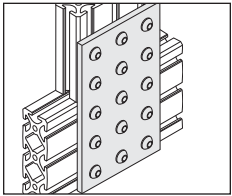

page 136

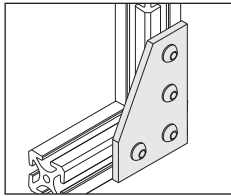

page 137

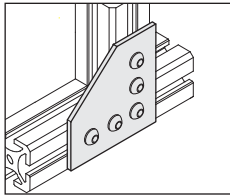

page 138

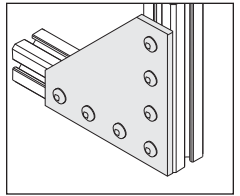

page 139

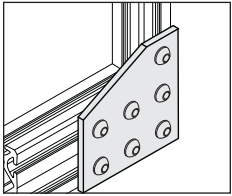

page 140

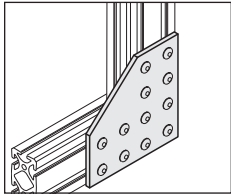

page 141

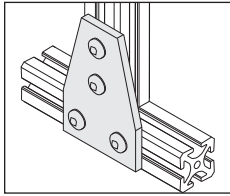

page 142

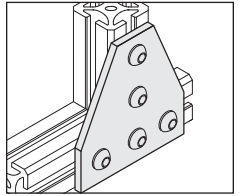

page 143



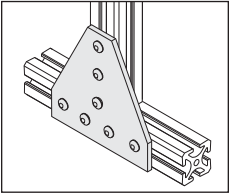

page 144

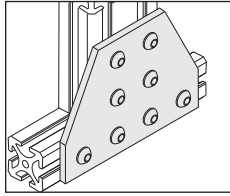

page 145

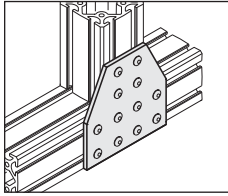

page 146

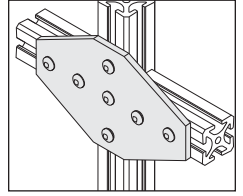

page 147

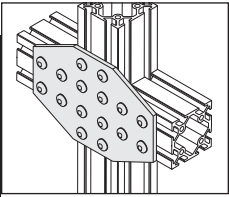

page 148

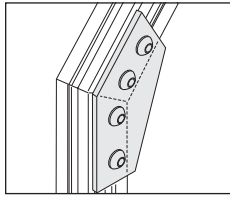

page 149

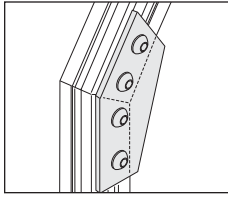

page 150

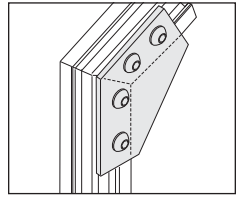

page 151

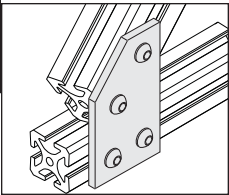

page 152

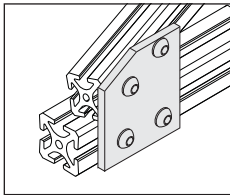

page 153

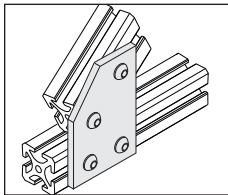

page 154

**Section C.6**  
**Floor Mounts,  
 Casters and  
 Adjustable  
 Feet**

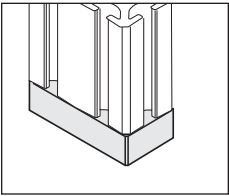

page 155

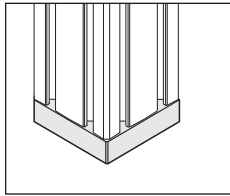

page 156

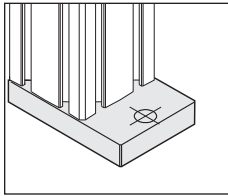

page 157

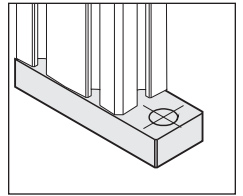

page 158

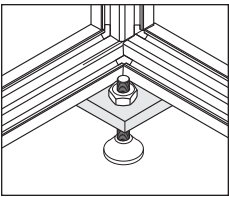

page 159

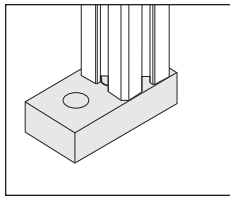

page 160

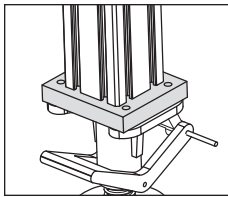

page 161, 162

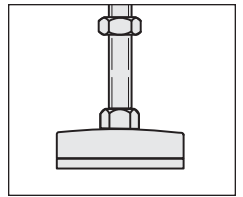

page 163

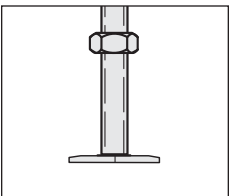

page 164

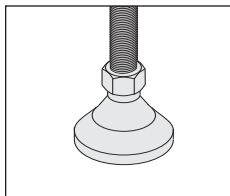

page 165

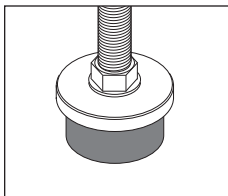

page 166

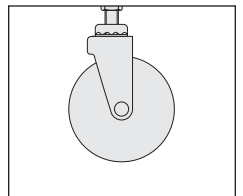

page 167

5/16" SLOTS

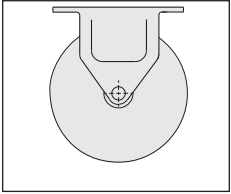

page 168

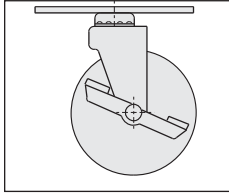

page 169

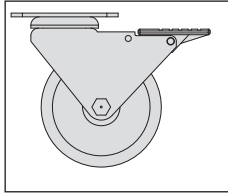

page 170

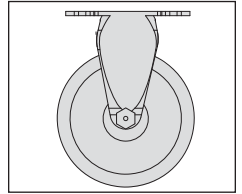

page 171

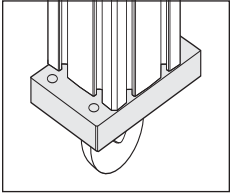

page 172

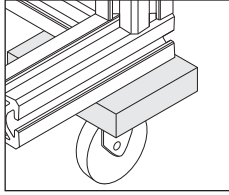

page 173

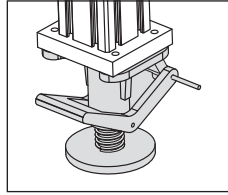

page 174

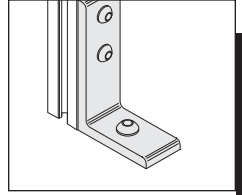

page 175

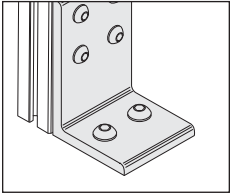

page 176

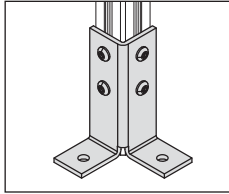

page 177

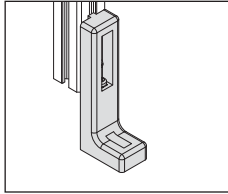

page 178

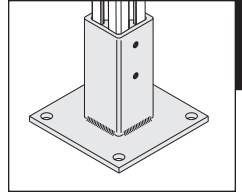

page 179

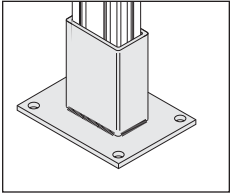

page 180

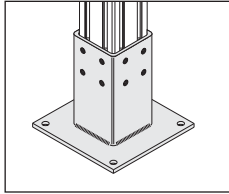

page 181

**Section C.7**  
**Panels, Doors**  
**and Hardware**

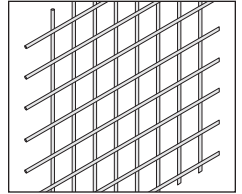

page 182

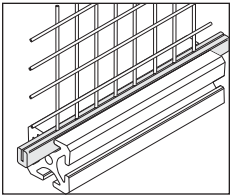

page 183

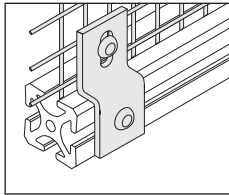

page 184

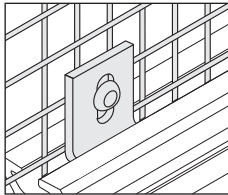

page 185

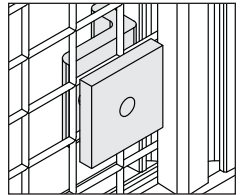

page 186

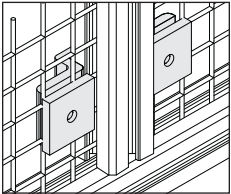

page 187

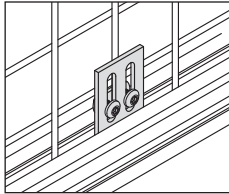

page 188

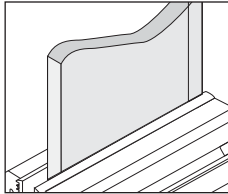

page 189

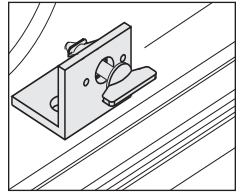

page 190

5/16" SLOTS

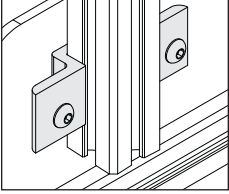

page 191

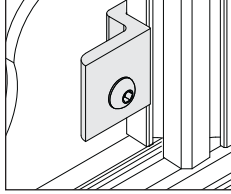

page 192

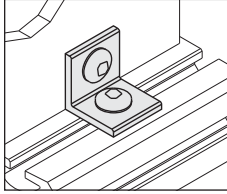

page 193

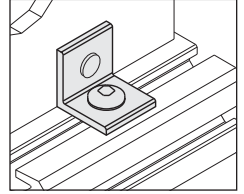

page 194

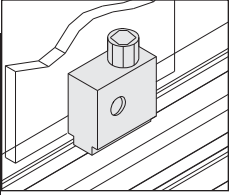

page 195

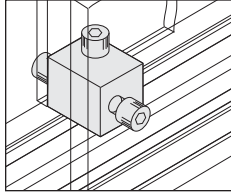

page 196

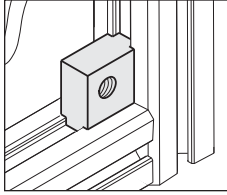

page 197

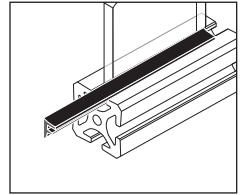

page 198

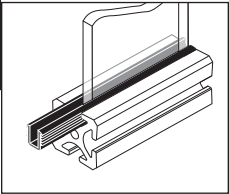

page 199

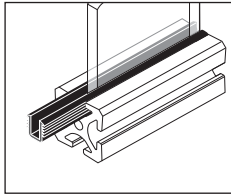

page 200

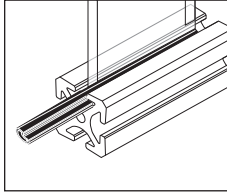

page 201

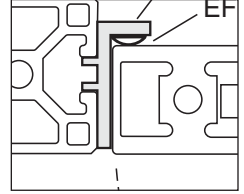

page 202

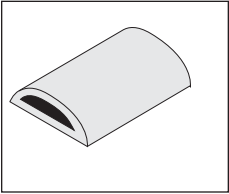

page 202

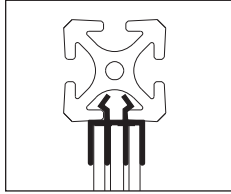

page 203

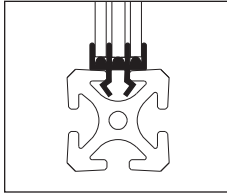

page 204

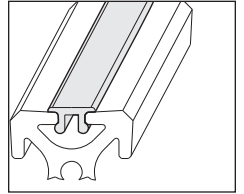

page 205

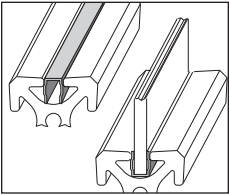

page 206

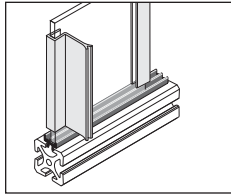

page 207

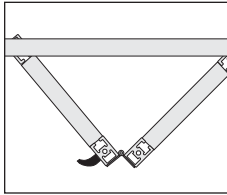

page 208

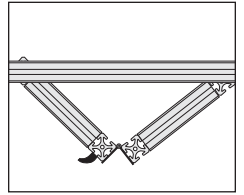

page 209

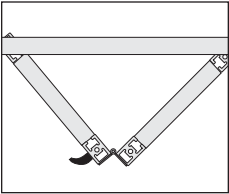

page 210

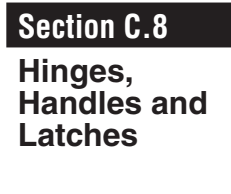

**Section C.8**

**Hinges,  
Handles and  
Latches**

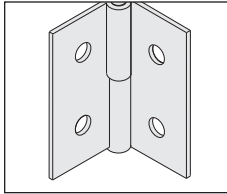

page 211

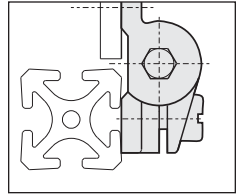

page 212

5/16" SLOTS

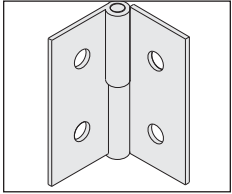

page 213

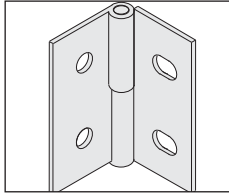

page 214

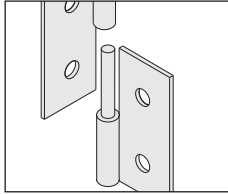

page 215

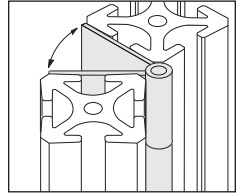

page 216

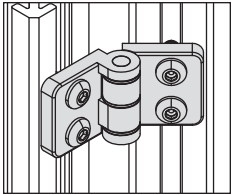

page 217

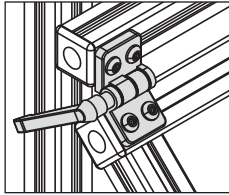

page 218

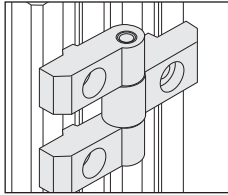

page 219

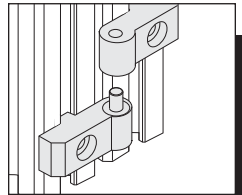

page 220

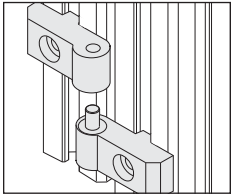

page 221

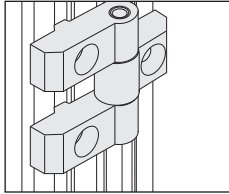

page 222

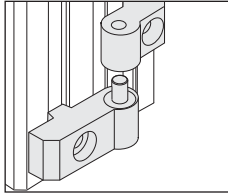

page 223

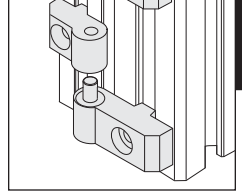

page 224

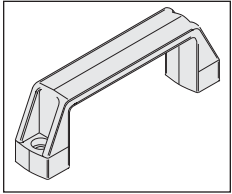

page 225

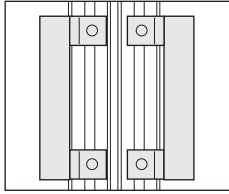

page 226

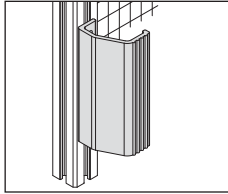

page 227

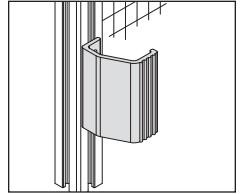

page 228

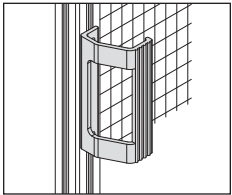

page 229

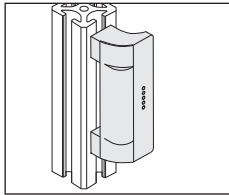

page 230

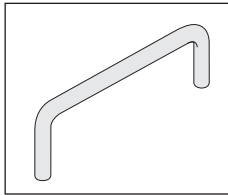

page 231

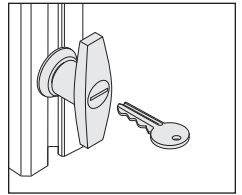

page 232

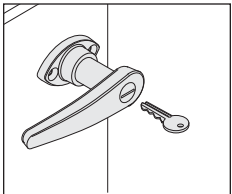

page 233

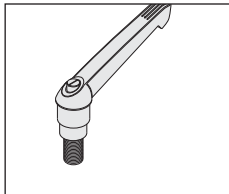

page 234

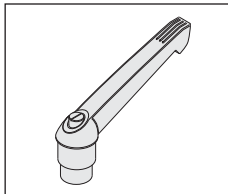

page 235

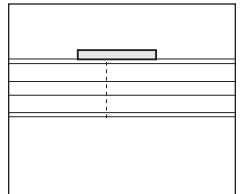

page 236

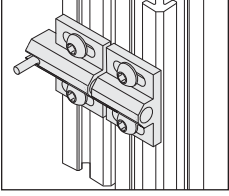

page 237

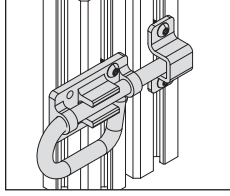

page 238

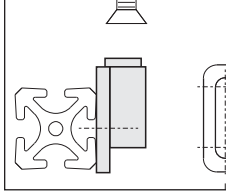

page 239

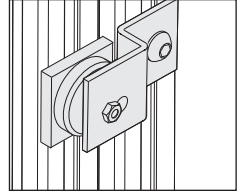

page 240

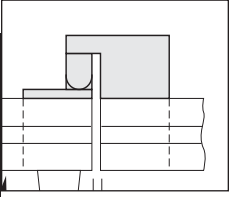

page 241

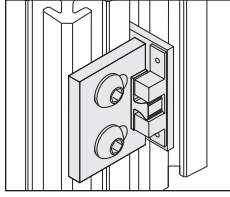

page 242

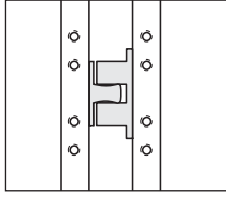

page 243

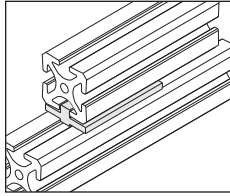

page 244

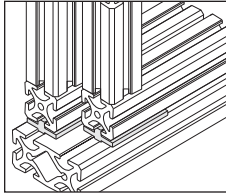

page 245

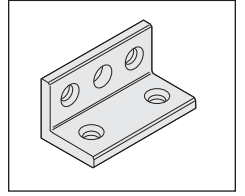

page 246

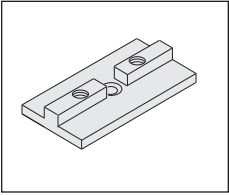

page 247

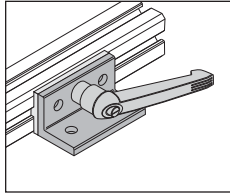

page 248

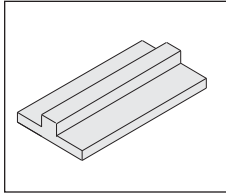

page 249

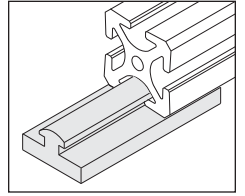

page 250

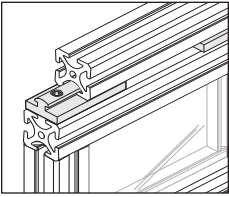

page 251

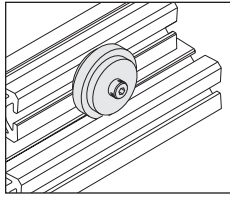

page 252

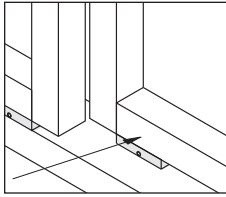

page 253

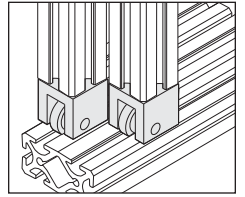

page 254

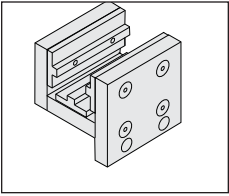

page 255

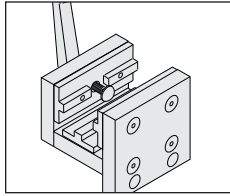

page 256

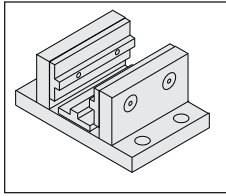

page 257

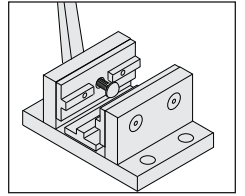

page 258

5/16" SLOTS

## Section C.9 Sliding Components and Bearings

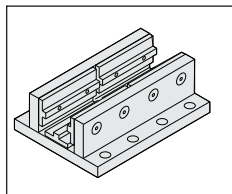

page 259

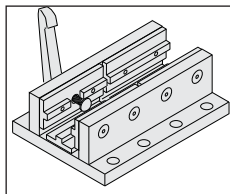

page 260

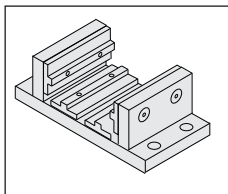

page 261

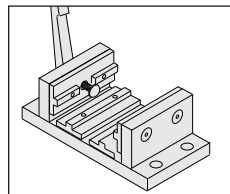

page 262

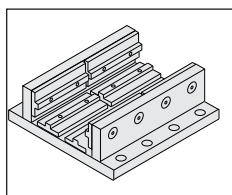

page 263

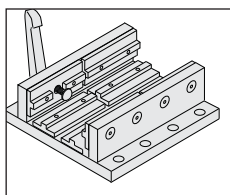

page 264

## Section C.10 Stanchions

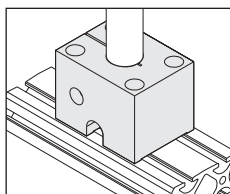

page 266

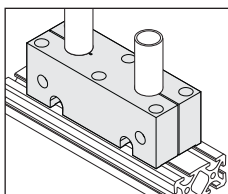

page 267

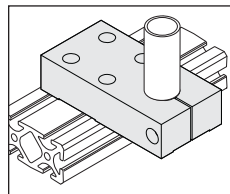

page 268

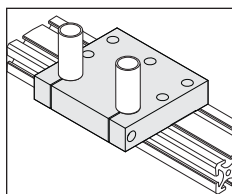

page 269

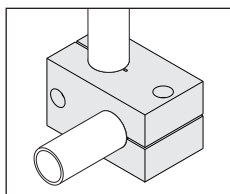

page 270

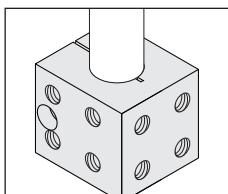

page 271

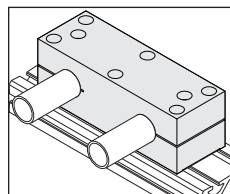

page 272

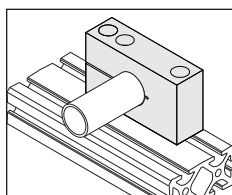

page 273

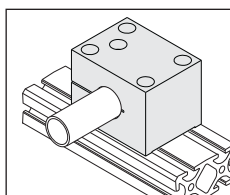

page 274

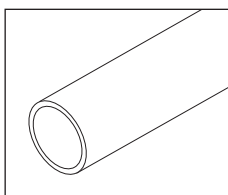

page 275

## Section C.11 Conveyor

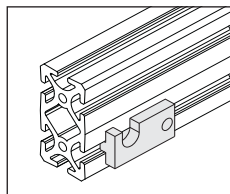

page 276

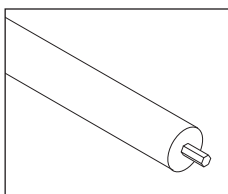

page 277

**Section C.12**

**Screws,  
Nuts &  
Fasteners**

**5/16" SLOTS**

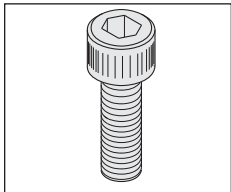

page 278

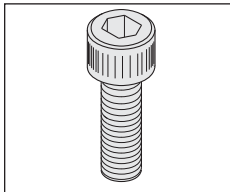

page 278

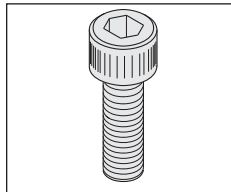

page 279

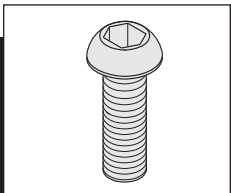

page 279

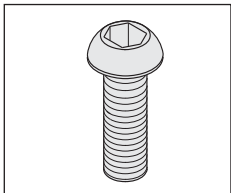

page 280

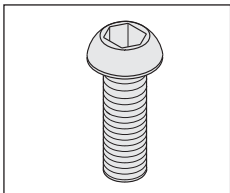

page 280

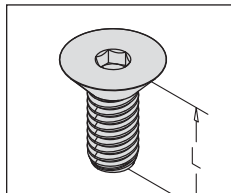

page 281

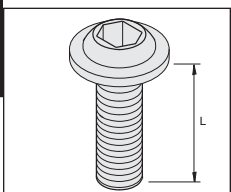

page 281

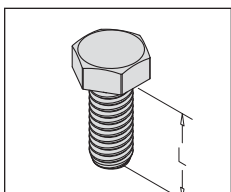

page 282

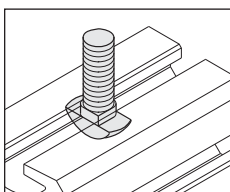

page 283

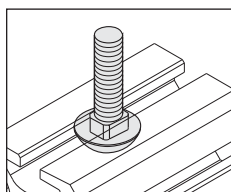

page 284

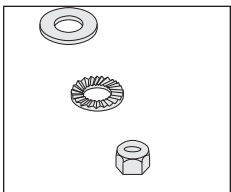

page 285

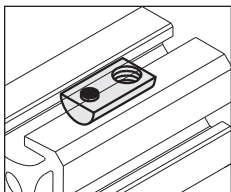

page 286

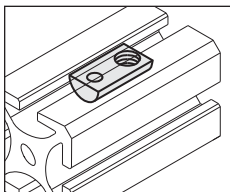

page 287

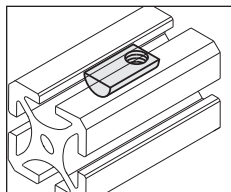

page 288

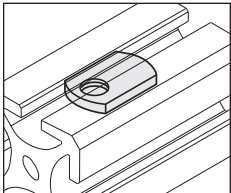

page 289

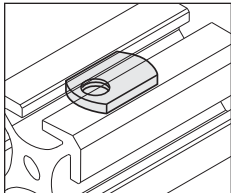

page 290

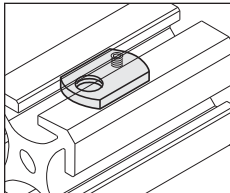

page 291

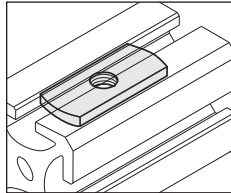

page 292

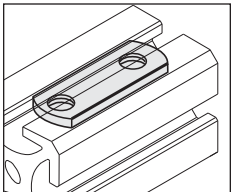

page 293

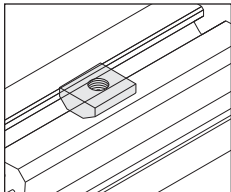

page 294

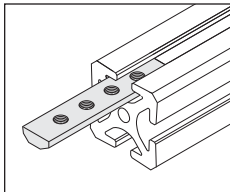

page 295

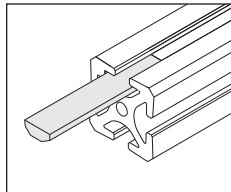

page 296

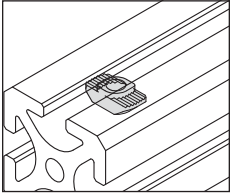

page 297

**Section C.13**  
**Miscellaneous**  
**Components**

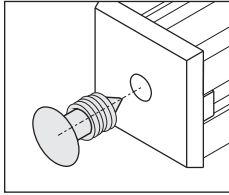

page 298

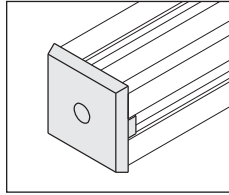

page 299

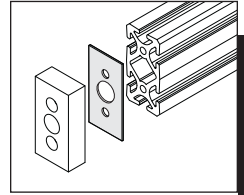

page 300

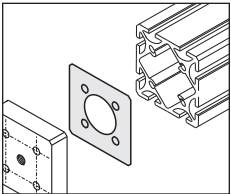

page 301

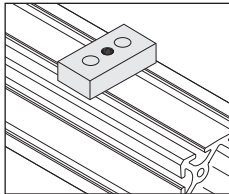

page 302

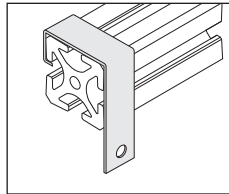

page 303

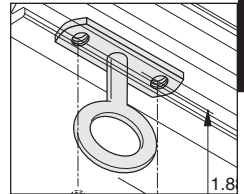

page 304

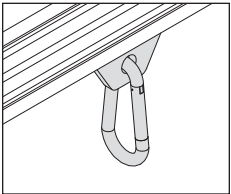

page 305

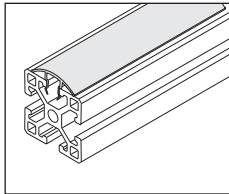

page 306

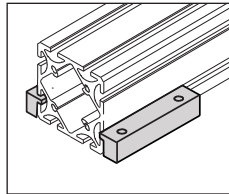

page 307

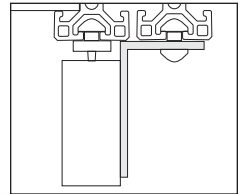

page 308

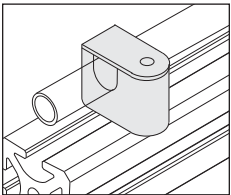

page 309

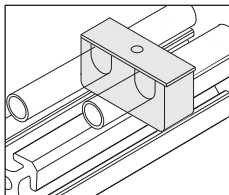

page 310

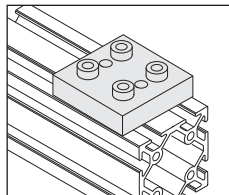

page 311

**5/16" SLOTS**



**EB-1**

5/16" SLOTS

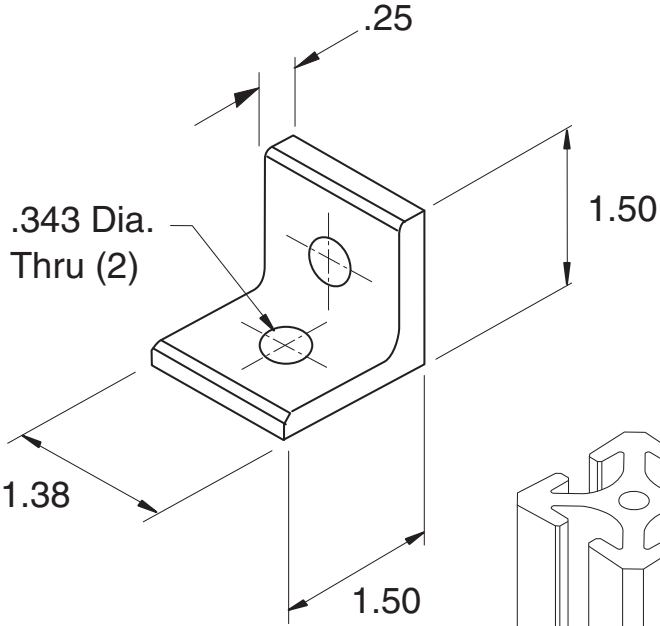

Recommended Hardware  
(2) EF-12-.63 BHCS  
(2) EF-2 T-nut

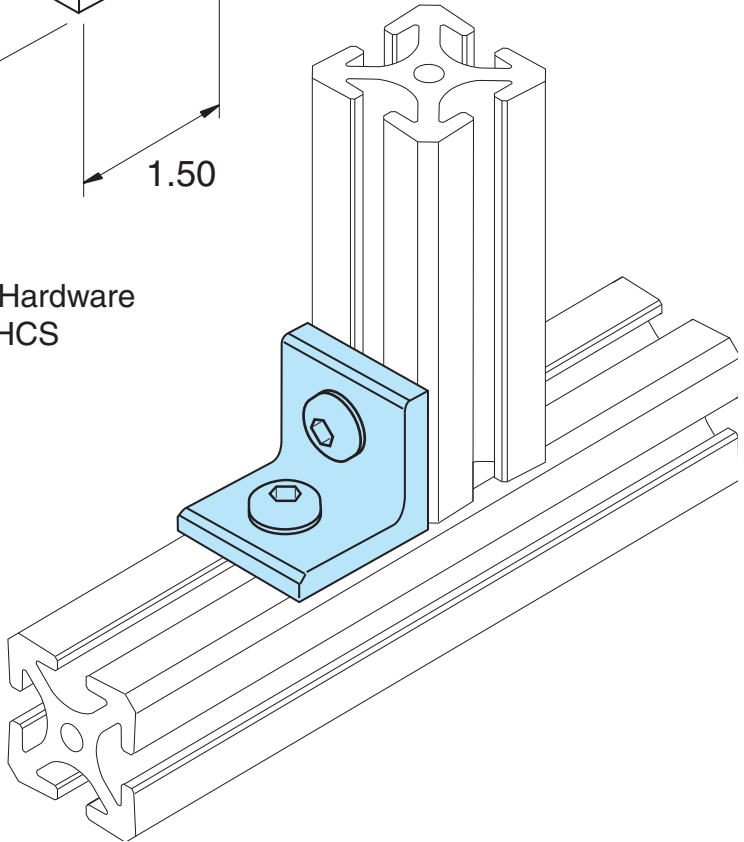

Material - Aluminum  
Finish - Clear Anodize

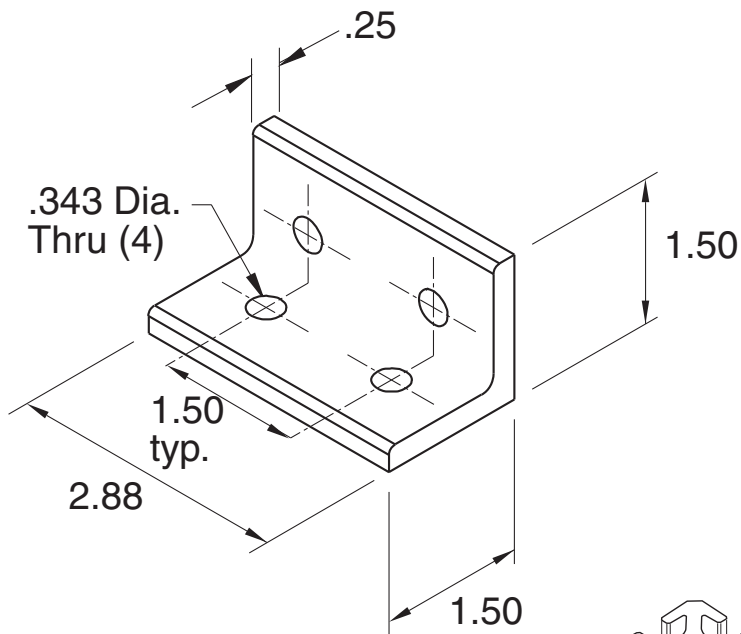

5/16" SLOTS

Recommended Hardware  
(4) EF-12-.63 BHCS  
(4) EF-2 T-nut

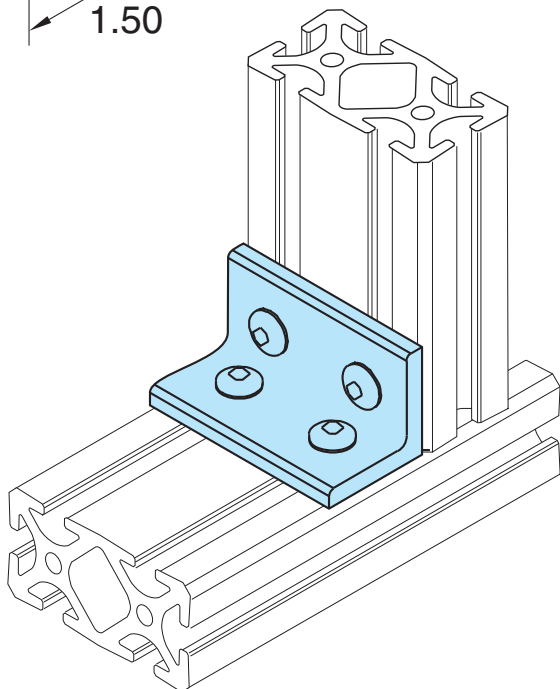

Material - Aluminum  
Finish - Clear Anodize

**EB-3**

5/16" SLOTS

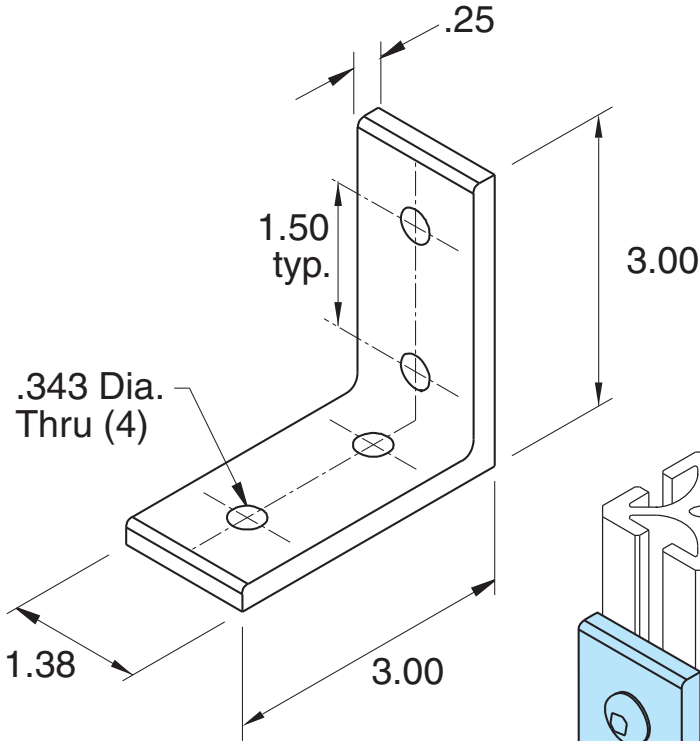

Recommended Hardware  
(4) EF-12-.63 BHCS  
(4) EF-2 T-nut

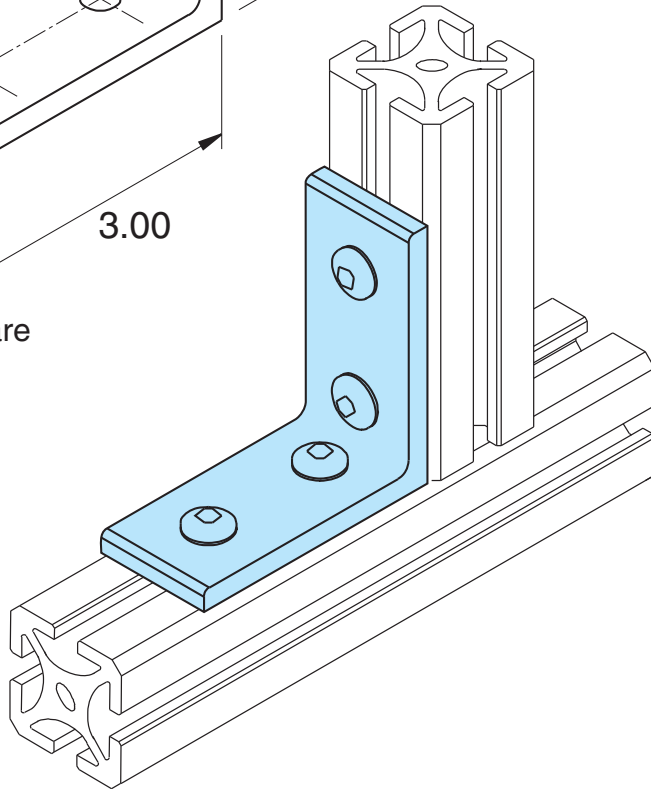

Material - Aluminum  
Finish - Clear Anodize

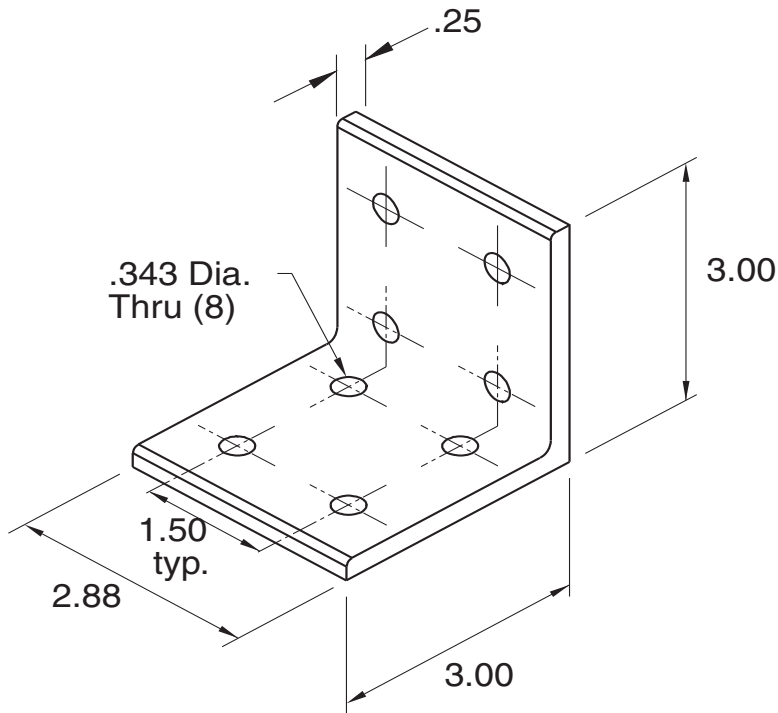

5/16" SLOTS

Recommended Hardware  
(8) EF-12-.63 BHCS  
(8) EF-2 T-nut

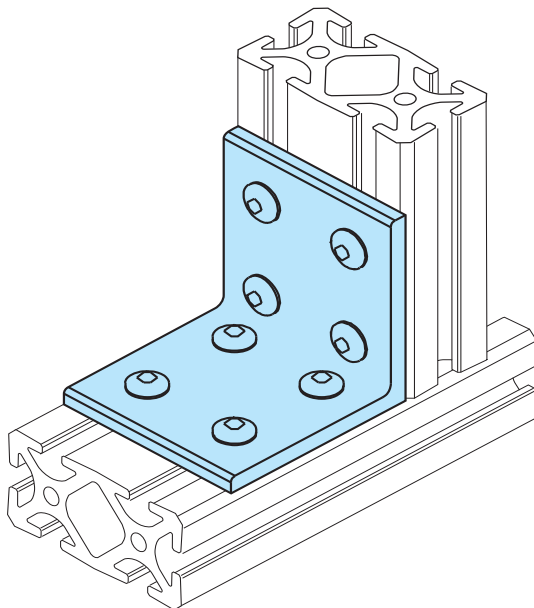

Material - Aluminum  
Finish - Clear Anodize

**EB-59**

5/16" SLOTS

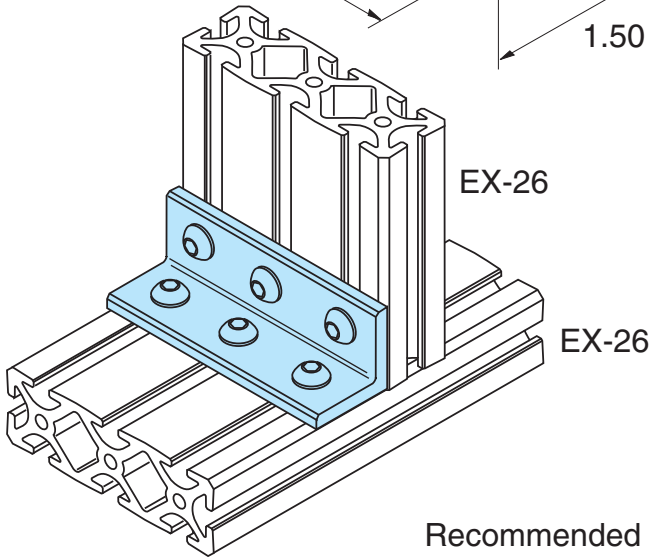
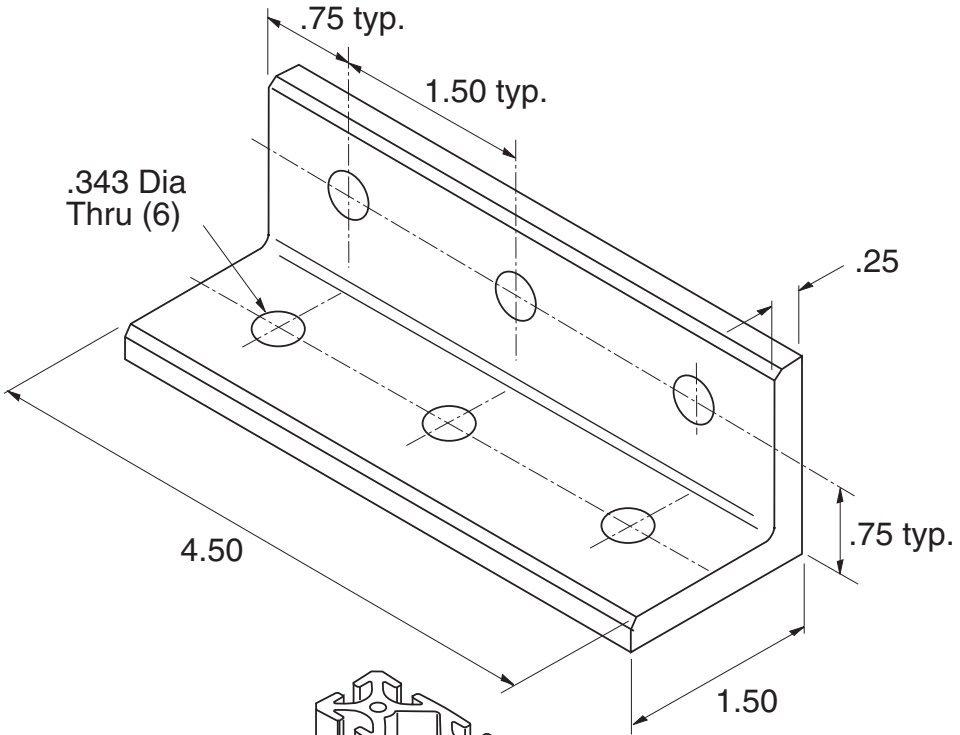

Recommended Hardware  
(6) EF-12-.63 BHCS  
(6) EF-2 T-nut

Material - Aluminum  
Finish - Clear Anodize

**EB-60**

**5/16" SLOTS**

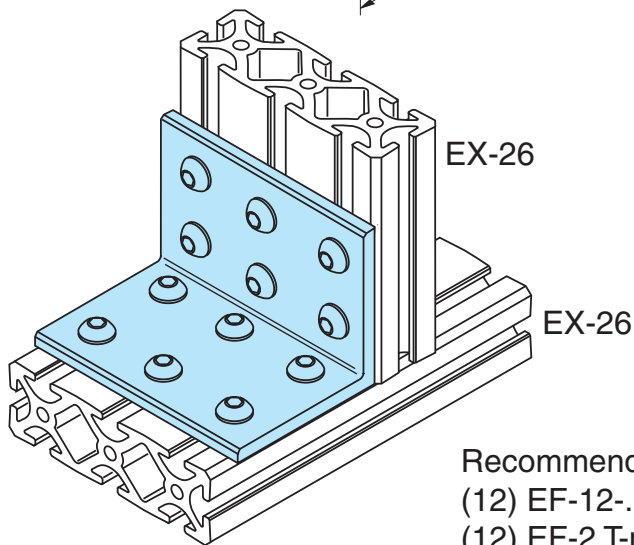
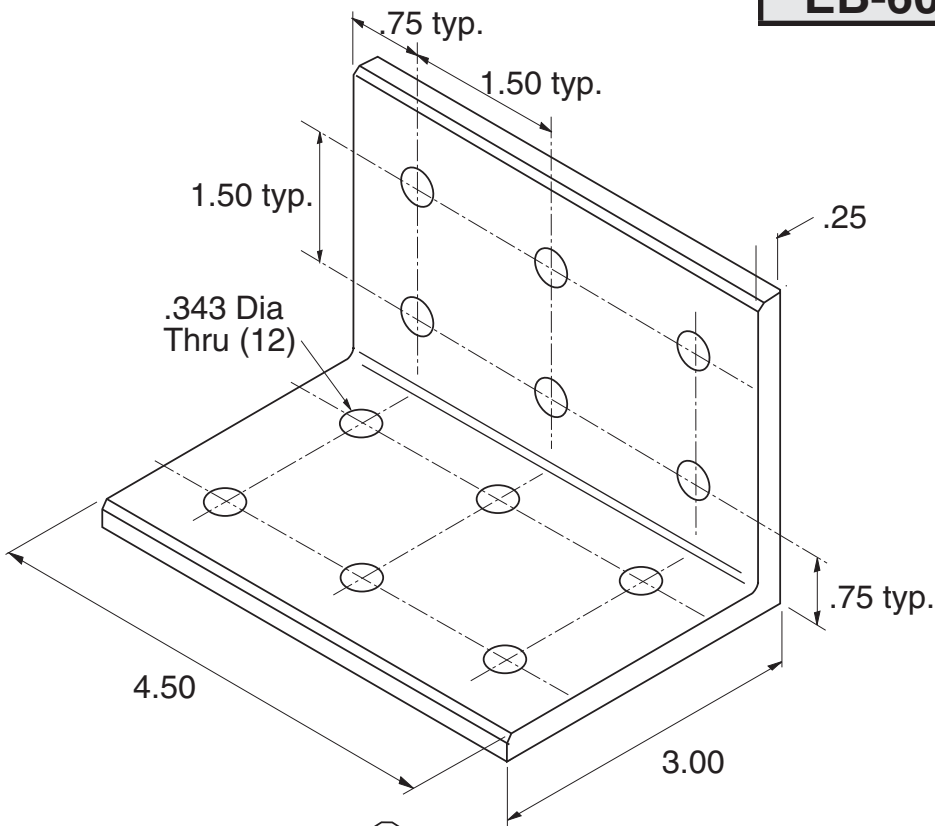

**Recommended Hardware**  
 (12) EF-12-.63 BHCS  
 (12) EF-2 T-nut

**Material - Aluminum**  
**Finish - Clear Anodize**

**EB-55**

5/16" SLOTS

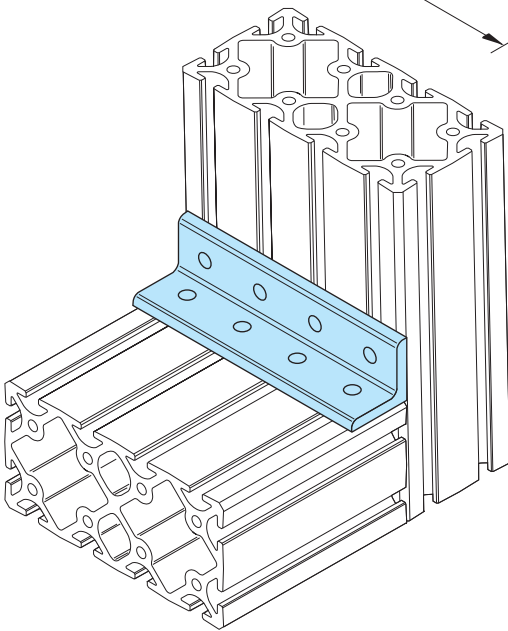
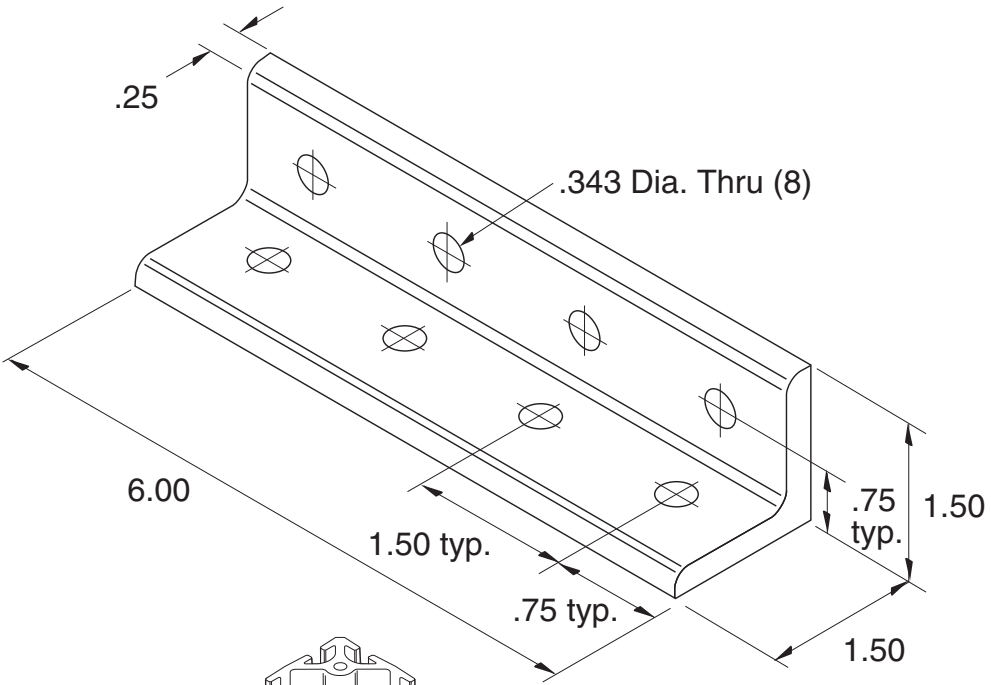

Recommended  
Hardware  
(8) EF-12-.63 BHCS  
(8) EF-2 T-nut

Material - Aluminum  
Finish - Clear Anodize

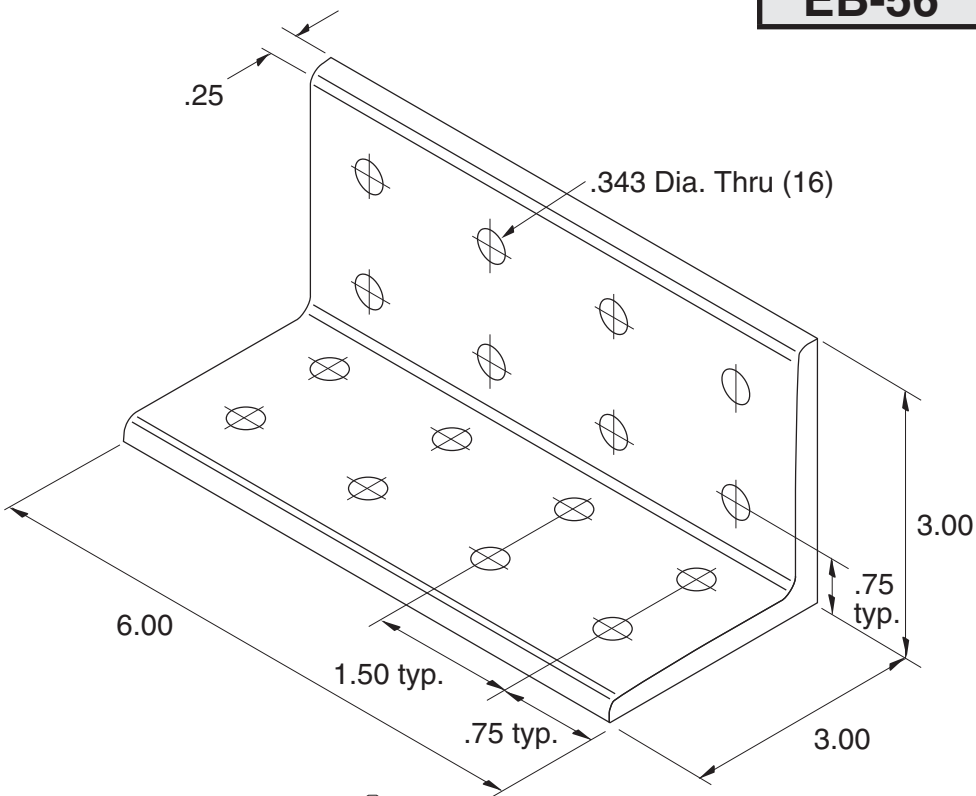

**5/16" SLOTS**

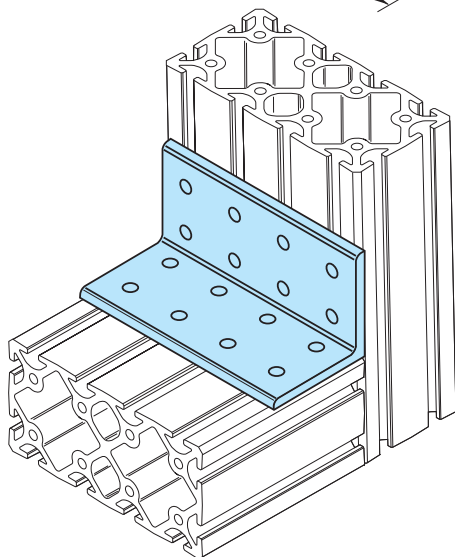

Recommended  
Hardware  
(16) EF-12-.63 BHCS  
(16) EF-2 T-nut

Material - Aluminum  
Finish - Clear Anodize



**EB-100**

5/16" SLOTS

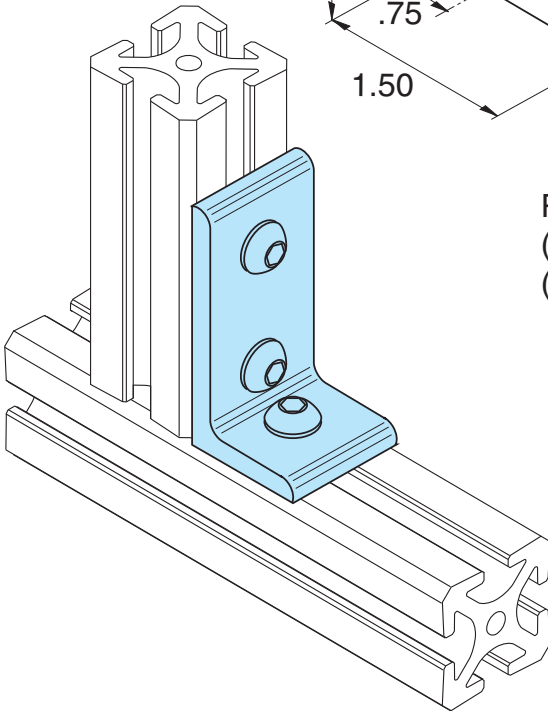
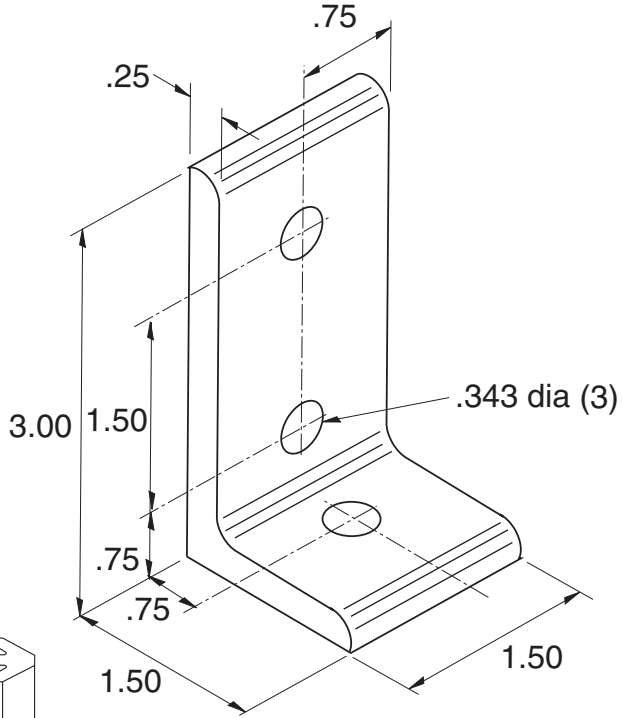

Recommended Hardware  
(3) EF-12-.63 BHCS  
(3) EF-2 T-nut

Material - Aluminum  
Finish - Clear Anodize

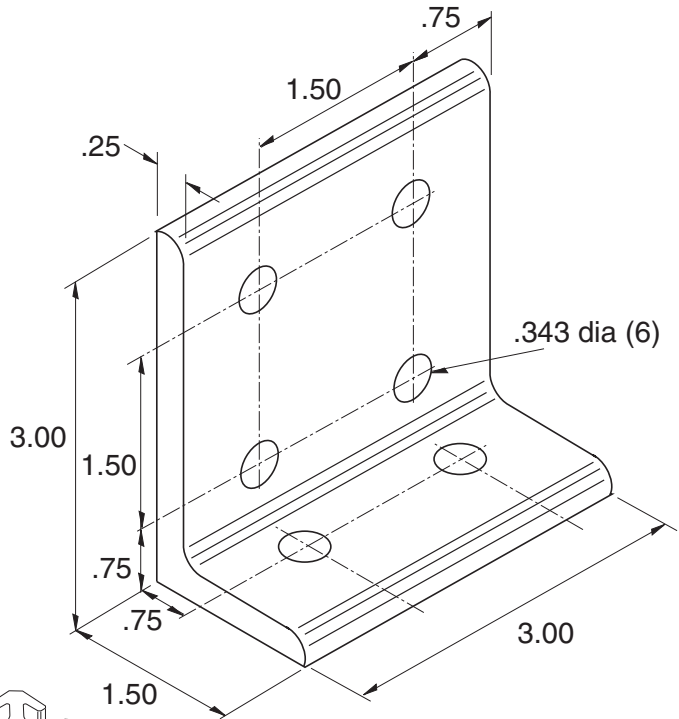

5/16" SLOTS

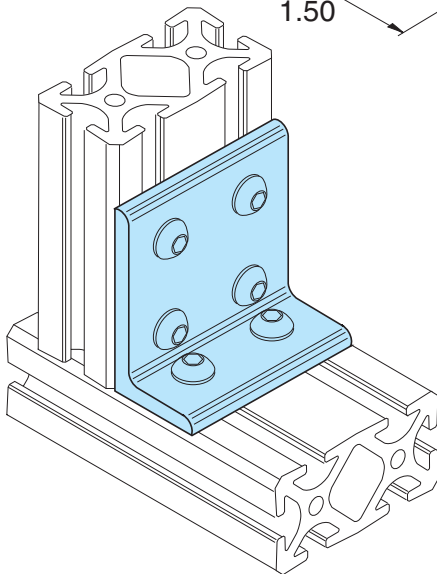

Recommended Hardware  
 (6) EF-12-.63 BHCS  
 (6) EF-2 T-nut

Material - Aluminum  
 Finish - Clear Anodize

**EB-102**

5/16" SLOTS

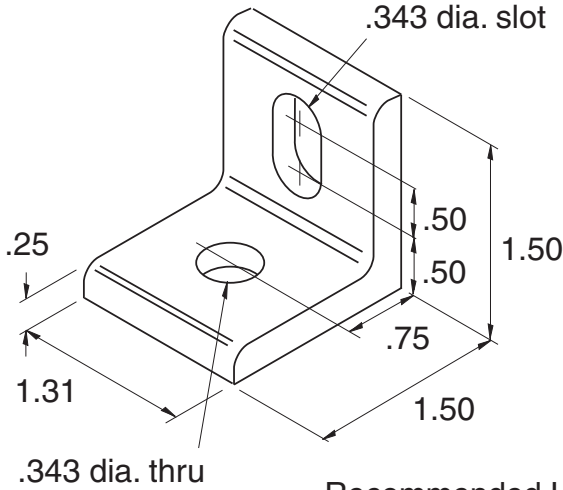

Recommended Hardware  
(2) EF-12-.63 BHCS  
(2) EF-2 T-nut

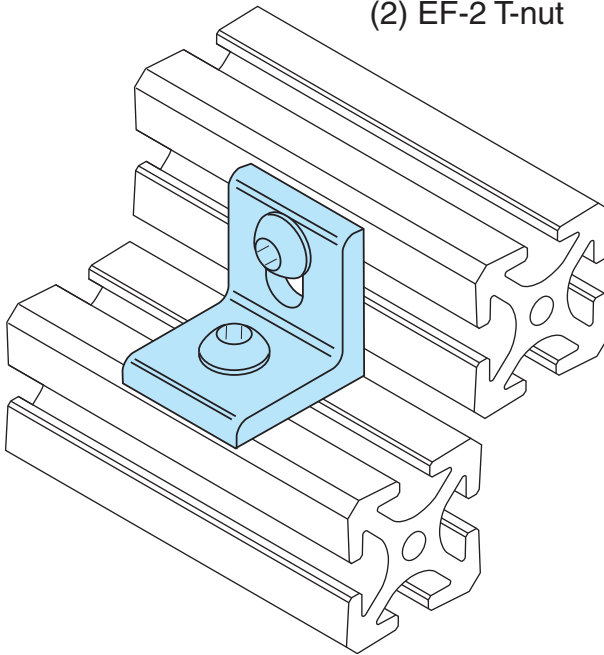

Material - Aluminum  
Finish - Clear Anodize

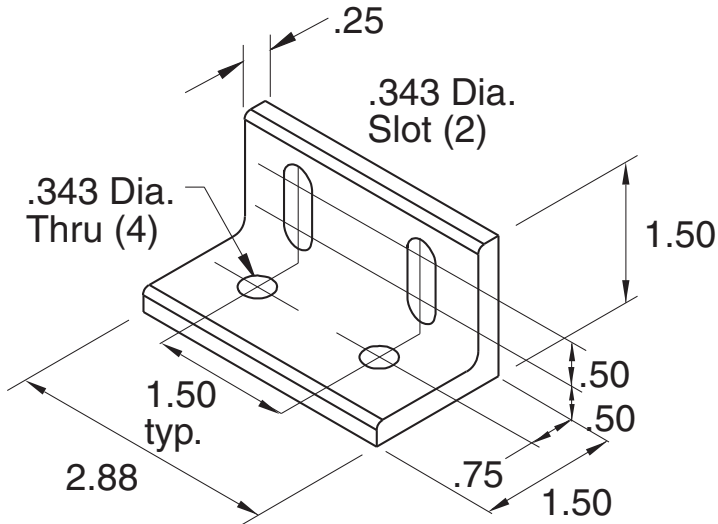

Recommended Hardware  
(4) EF-12-.63 BHCS  
(4) EF-2 T-nut

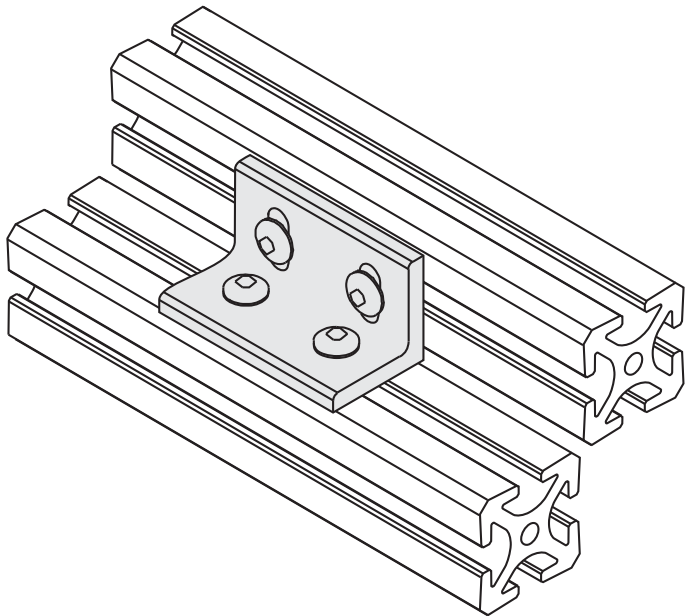

Material - Aluminum  
Finish - Clear Anodize

**5/16" SLOTS**

**EB-81**

5/16" SLOTS

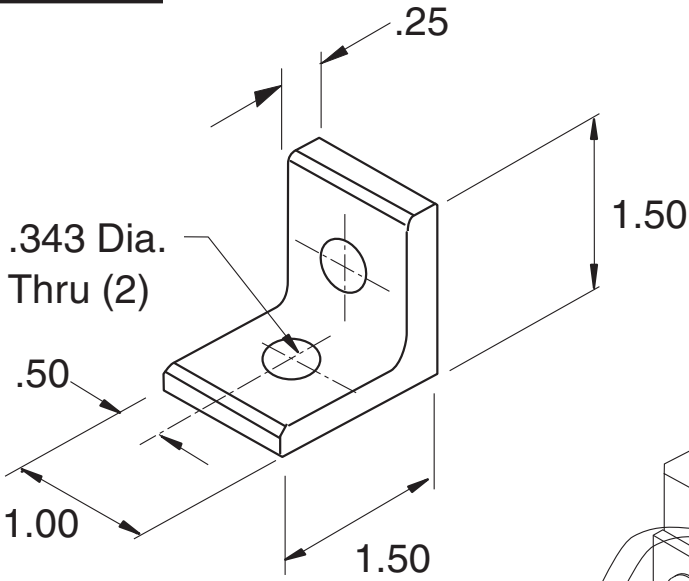

Recommended Hardware

- (2) EF-12-.63 BHCS
- (2) EF-2 T-nut

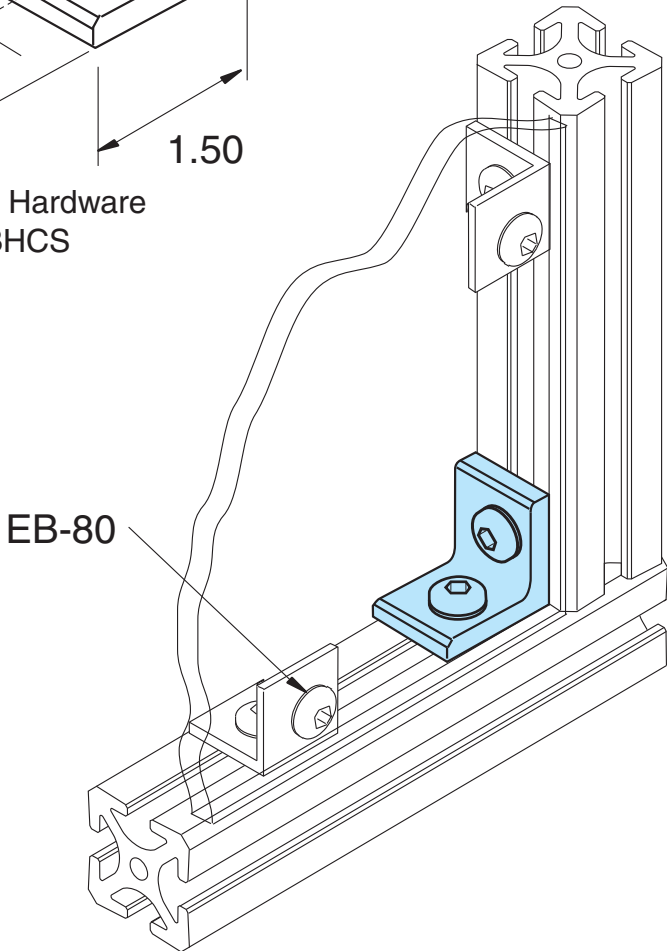
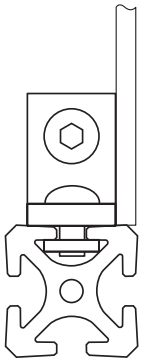

Material - Aluminum  
Finish - Clear Anodize

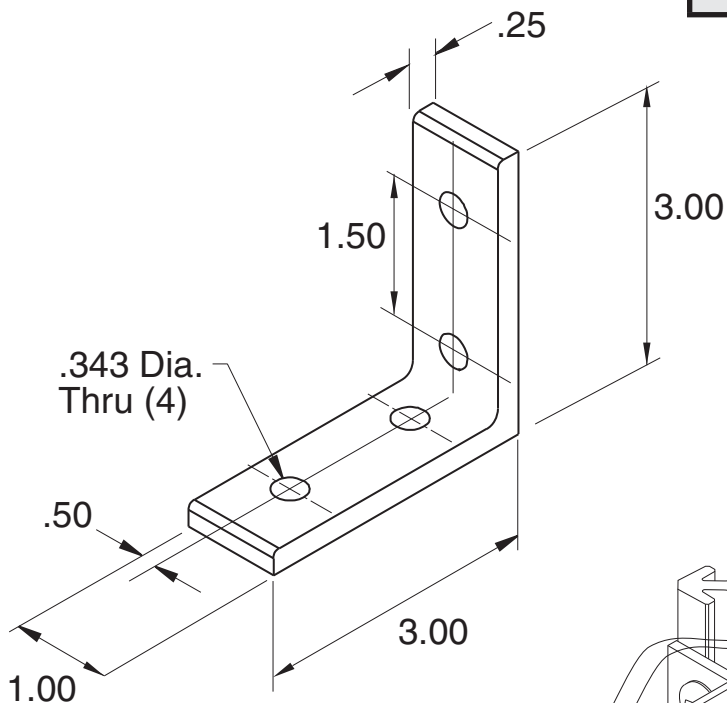

**5/16" SLOTS**

**Recommended Hardware**  
 (4) EF-12-.63 BHCS  
 (4) EF-2 T-nut

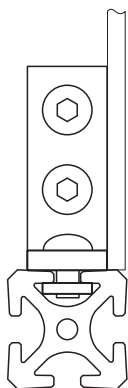

**EB-82**

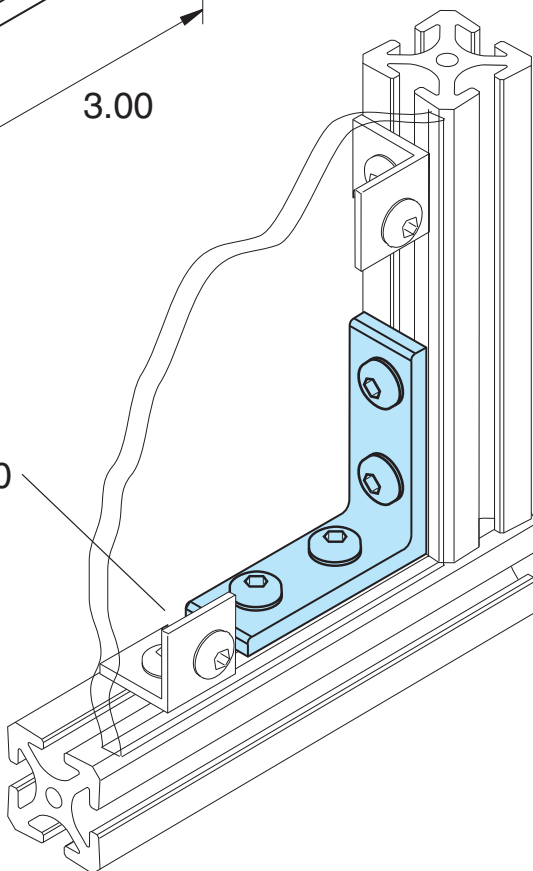

**Material - Aluminum**  
**Finish - Clear Anodize**

**EB-30**

**5/16" SLOTS**

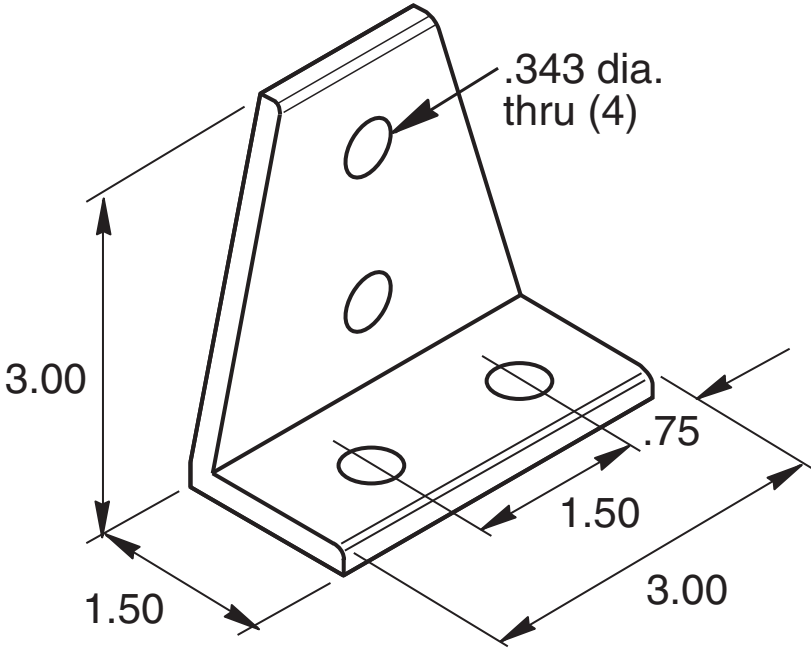

Recommended Hardware  
(4) EF-12-.63 BHCS  
(4) EF-2 T-nut

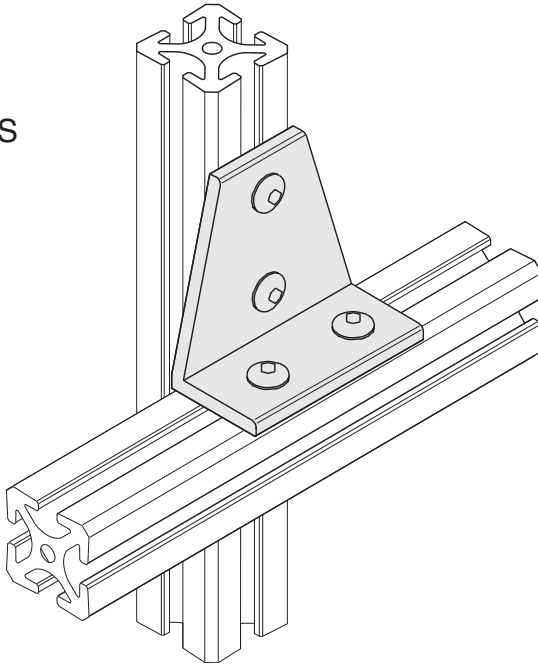

Material - Aluminum  
Finish - Clear Anodize

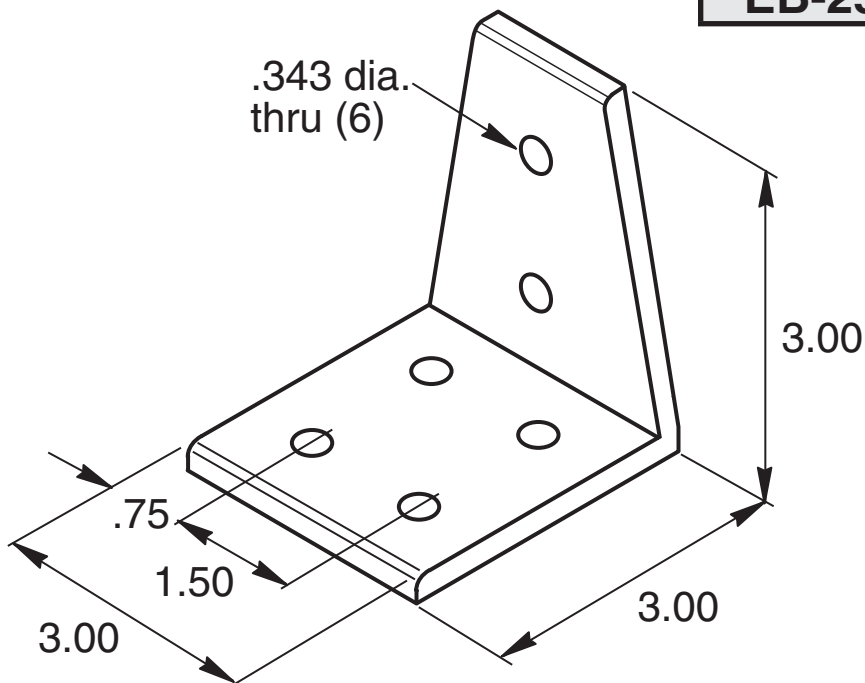

5/16" SLOTS

Recommended  
Hardware  
(6) EF-12-.63 BHCS  
(6) EF-2 T-nut

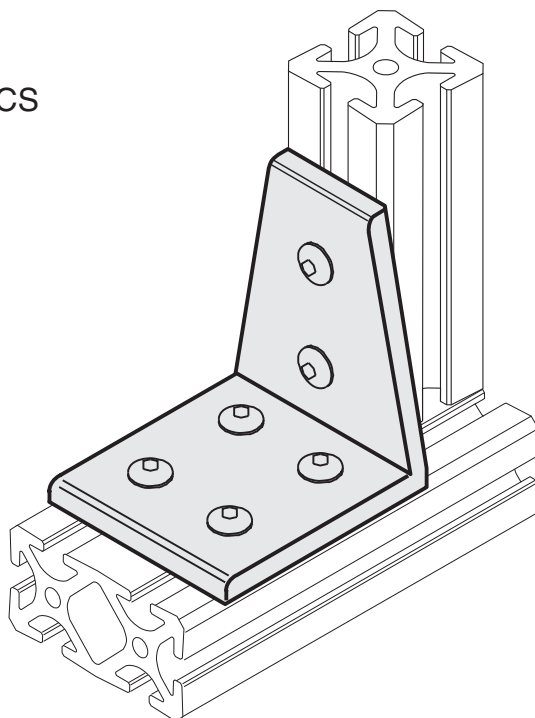

Material - Aluminum  
Finish - Clear Anodize



**EB-57**

5/16" SLOTS

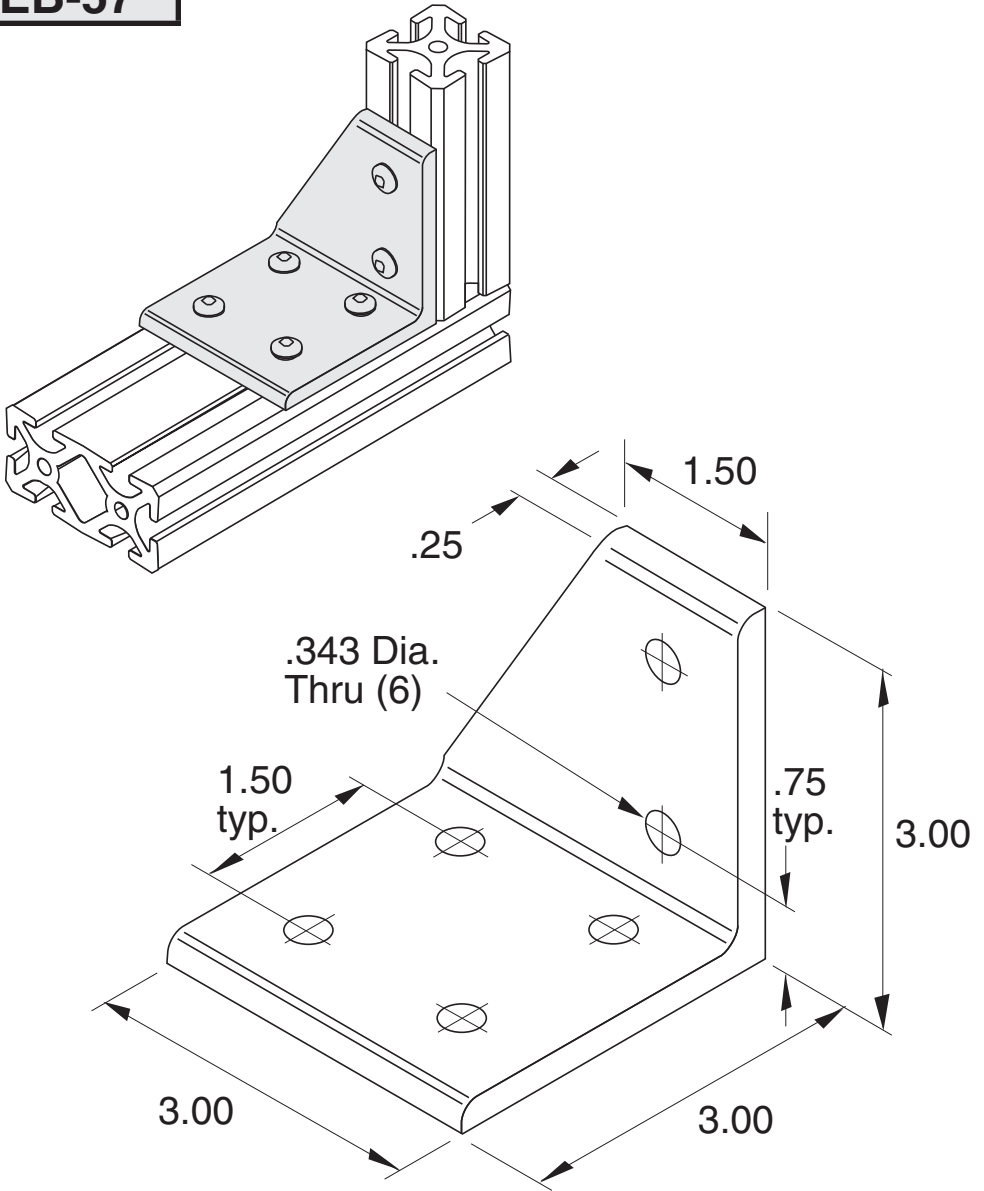

Recommended Hardware  
(6) EF-12-.63 BHCS  
(6) EF-2 T-nut

Material - Aluminum  
Finish - Clear Anodize

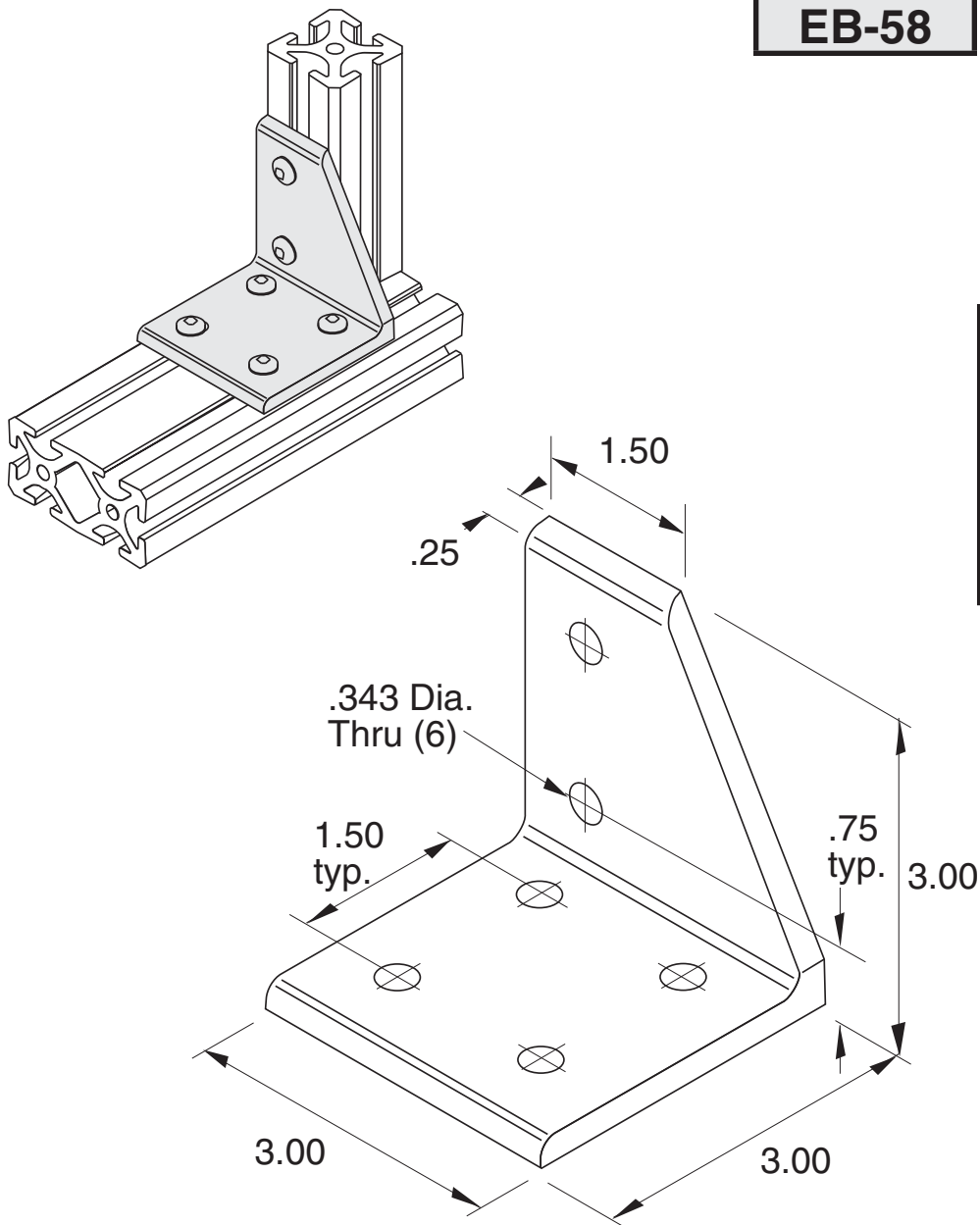

Recommended Hardware  
(6) EF-12-.63 BHCS  
(6) EF-2 T-nut

Material - Aluminum  
Finish - Clear Anodize

**EB-111**

5/16" SLOTS

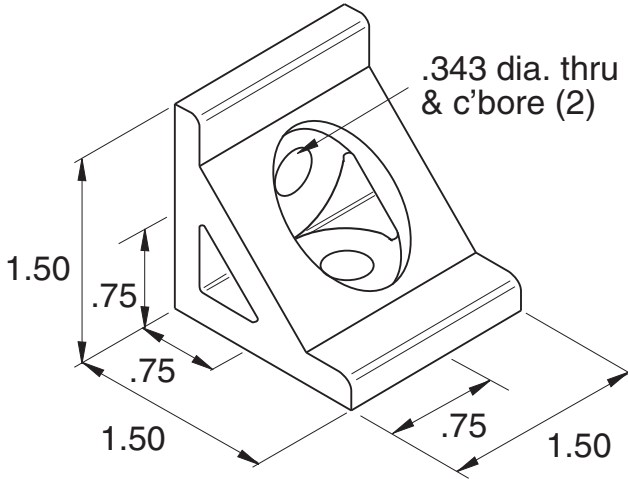

Recommended Hardware  
(2) EF-12-.63 BHCS  
(2) EF-2 T-nut

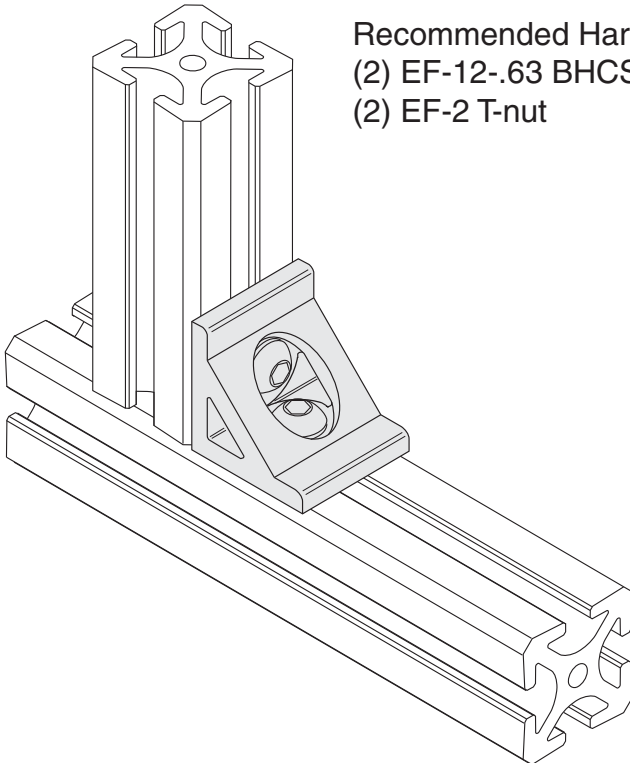

Material - Aluminum  
Finish - Clear Anodize

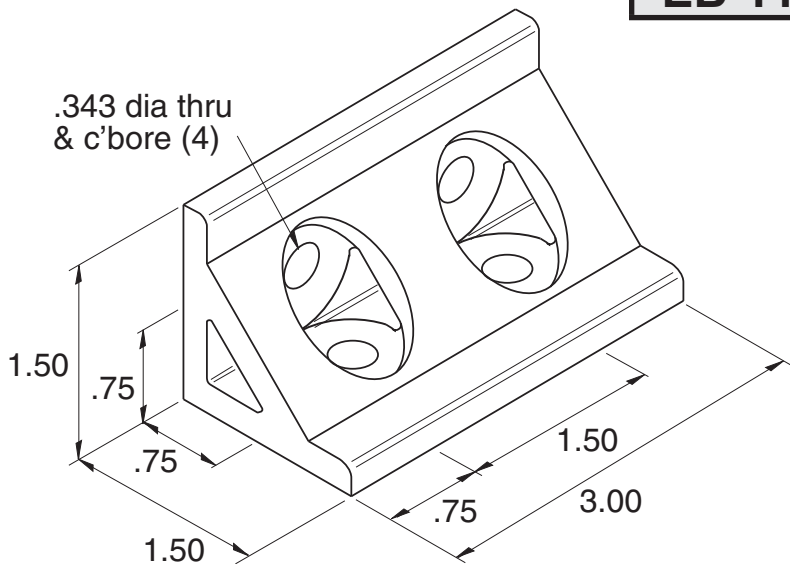

**5/16" SLOTS**

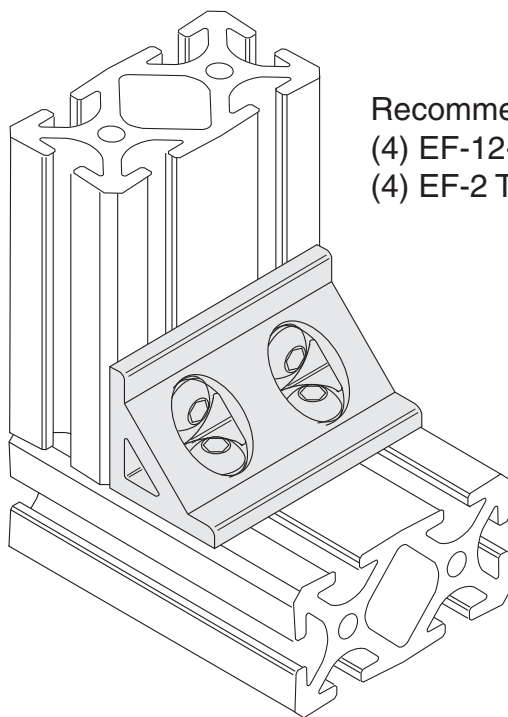

**Recommended Hardware**  
(4) EF-12-.63 BHCS  
(4) EF-2 T-nut

**Material - Aluminum**  
**Finish - Clear Anodize**

**EB-113**

5/16" SLOTS

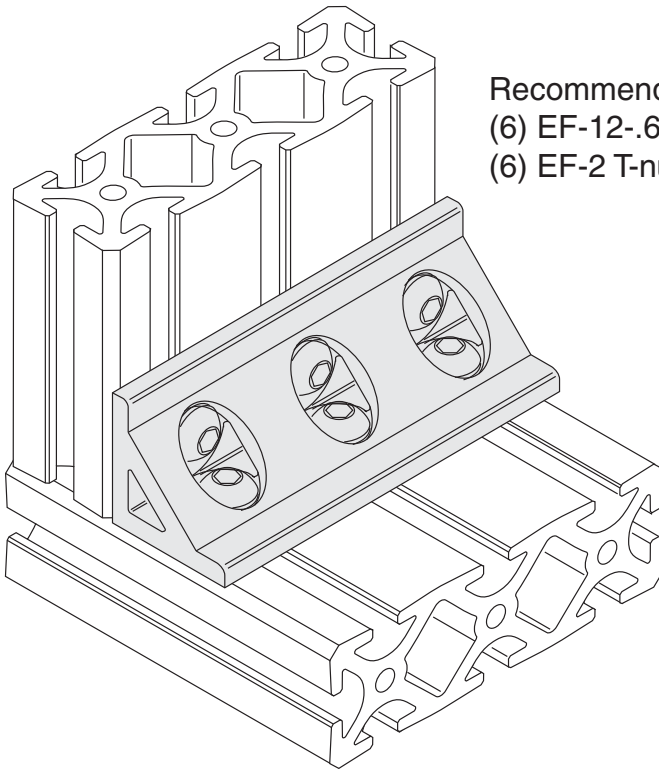
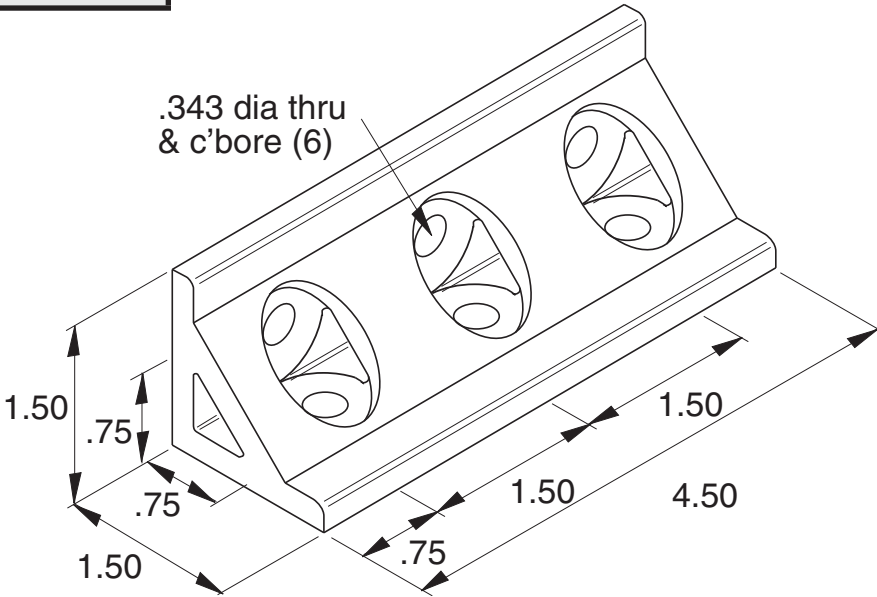

Recommended Hardware  
(6) EF-12-.63 BHCS  
(6) EF-2 T-nut

Material - Aluminum  
Finish - Clear Anodize

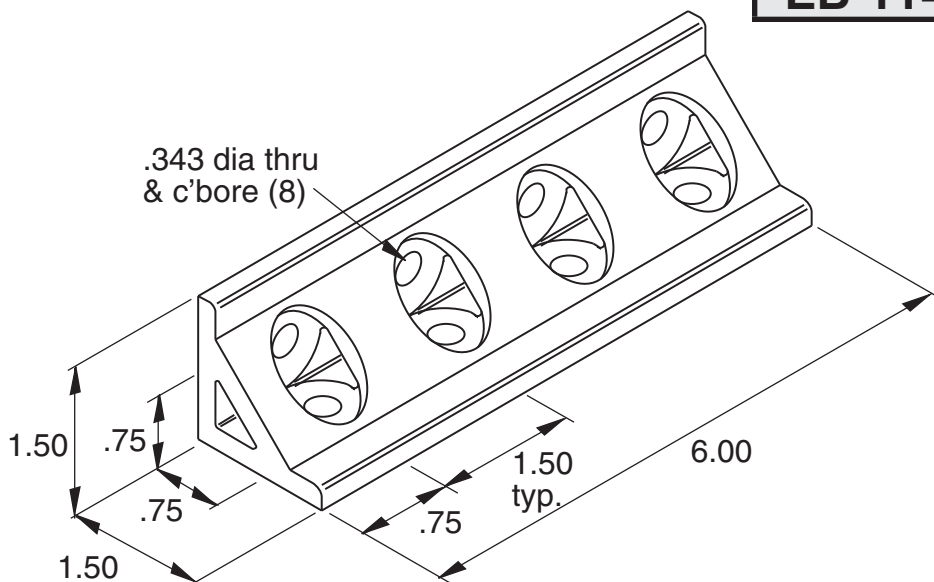

**5/16" SLOTS**

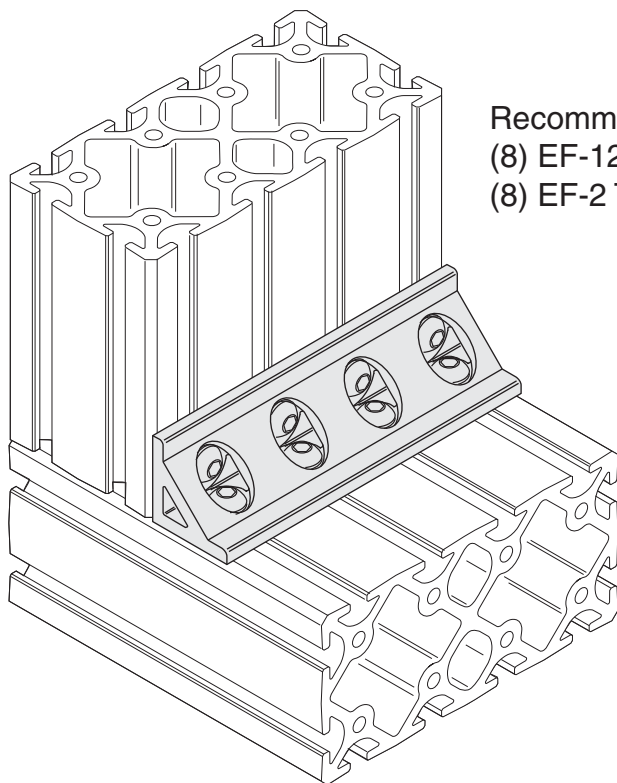

**Recommended Hardware**  
(8) EF-12-.63 BHCS  
(8) EF-2 T-nut

**Material - Aluminum**  
**Finish - Clear Anodize**

**EB-121**

**5/16" SLOTS**

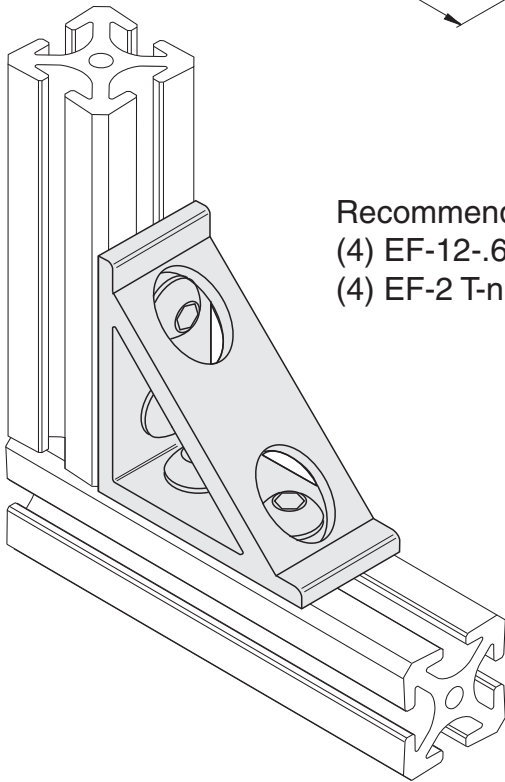
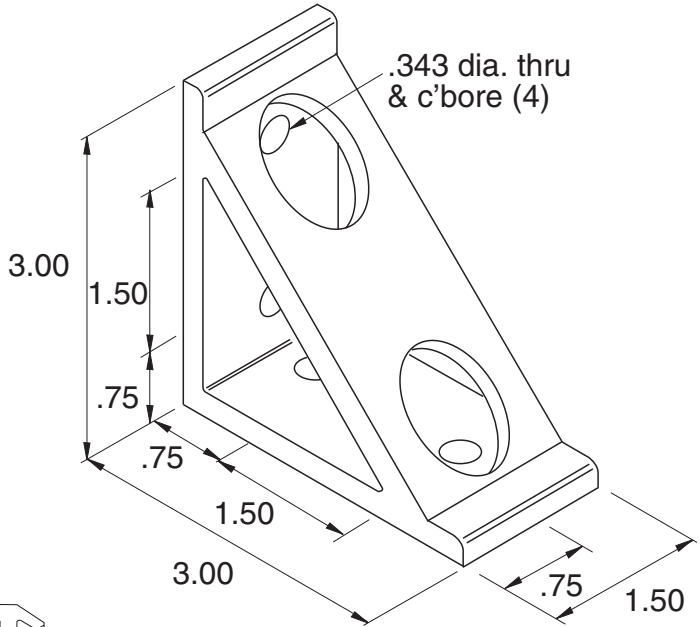

Recommended Hardware  
(4) EF-12-.63 BHCS  
(4) EF-2 T-nut

Material - Aluminum  
Finish - Clear Anodize

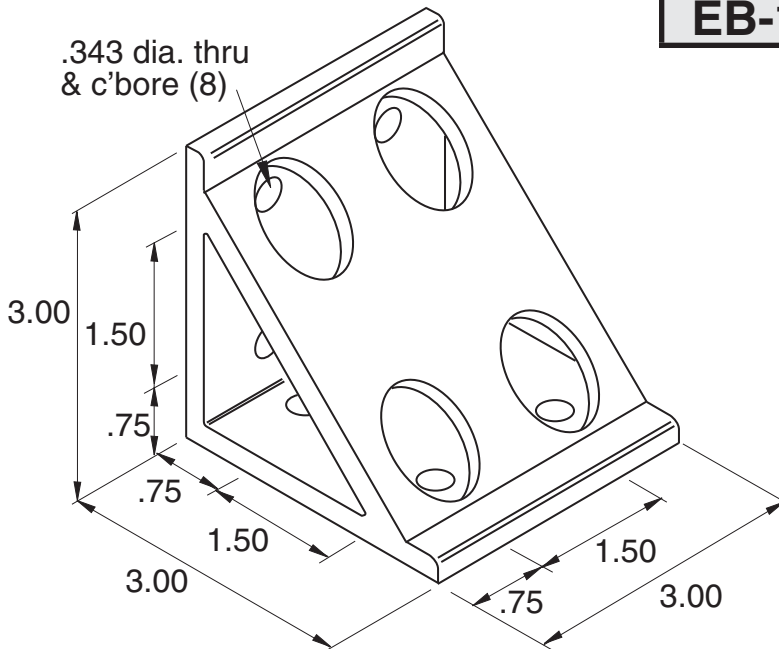

**5/16" SLOTS**

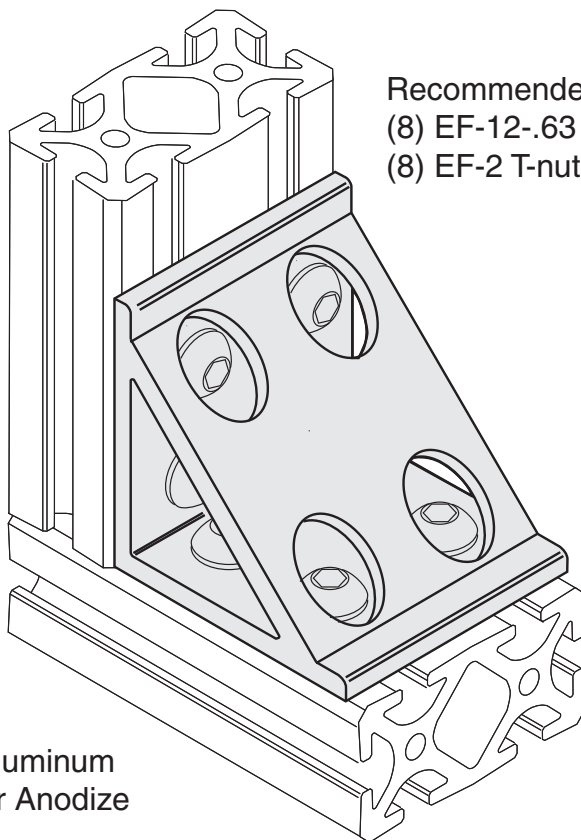

**Recommended Hardware**  
 (8) EF-12-.63 BHCS  
 (8) EF-2 T-nut

**Material - Aluminum**  
**Finish - Clear Anodize**



**EB-123**

5/16" SLOTS

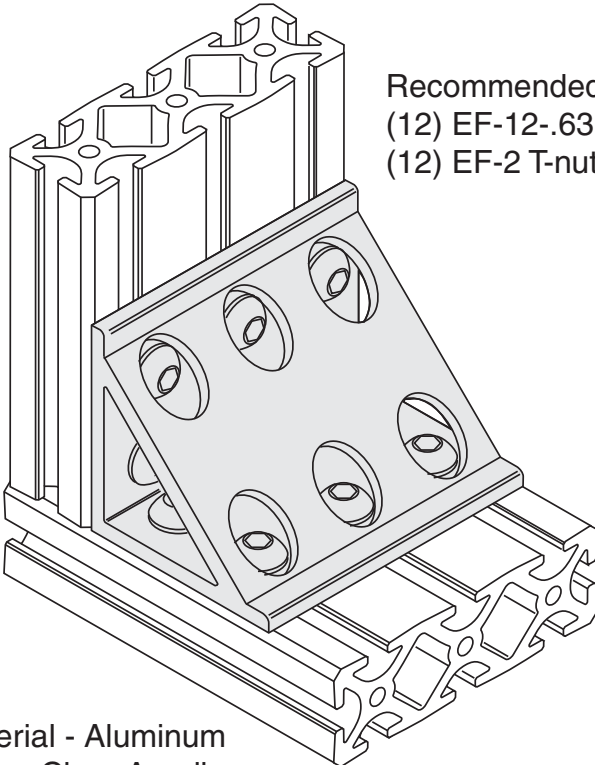
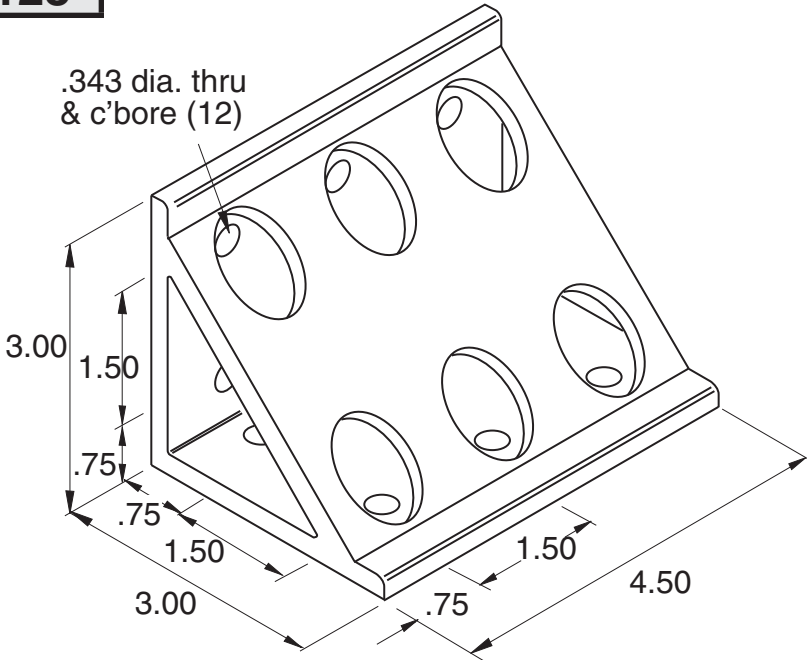

Recommended Hardware  
(12) EF-12-.63 BHCS  
(12) EF-2 T-nut

Material - Aluminum  
Finish - Clear Anodize

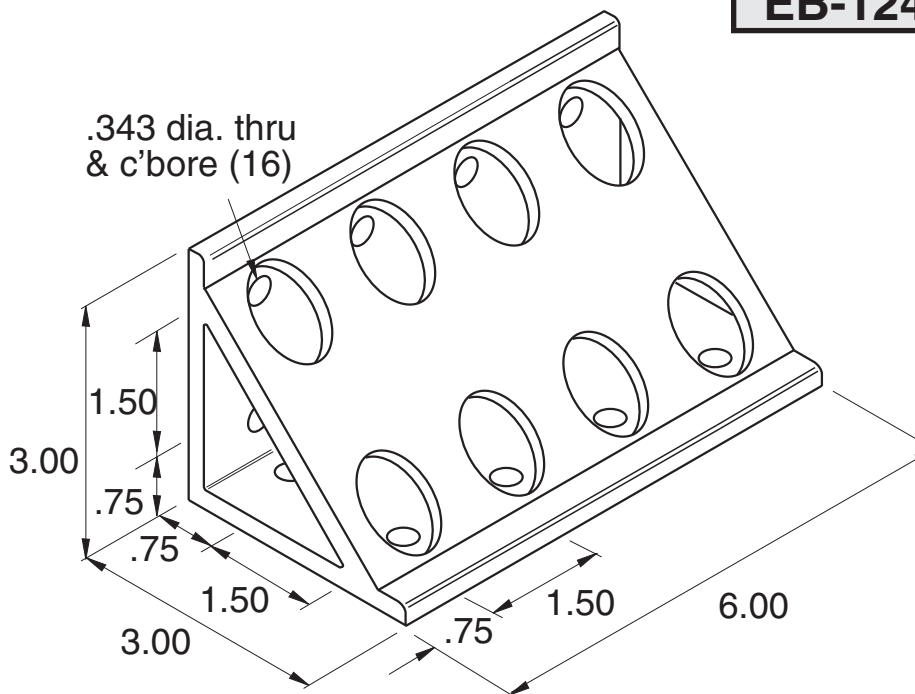

**5/16" SLOTS**

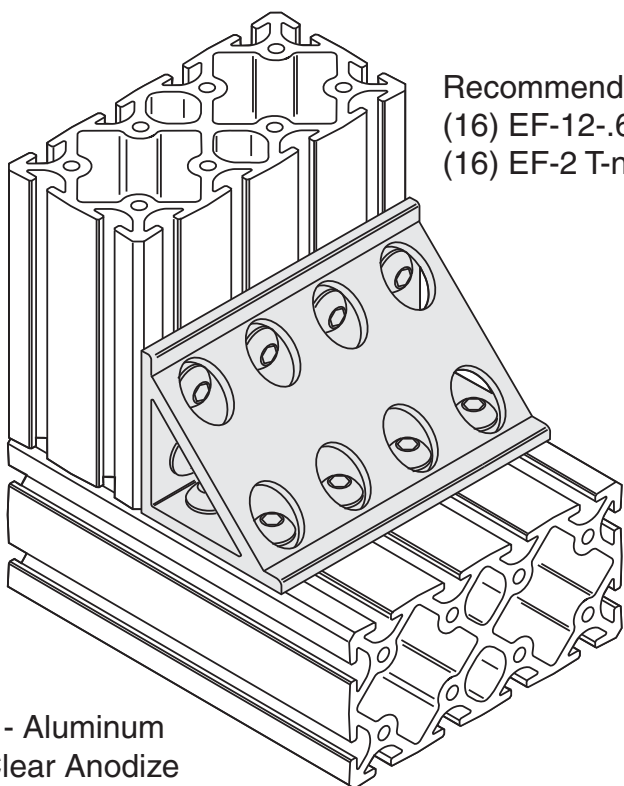

**Recommended Hardware**  
 (16) EF-12-.63 BHCS  
 (16) EF-2 T-nut

**Material - Aluminum**  
**Finish - Clear Anodize**

1.5 x 1.5 Extrusion  
Corner Gusset



**EB-6**

5/16" SLOTS

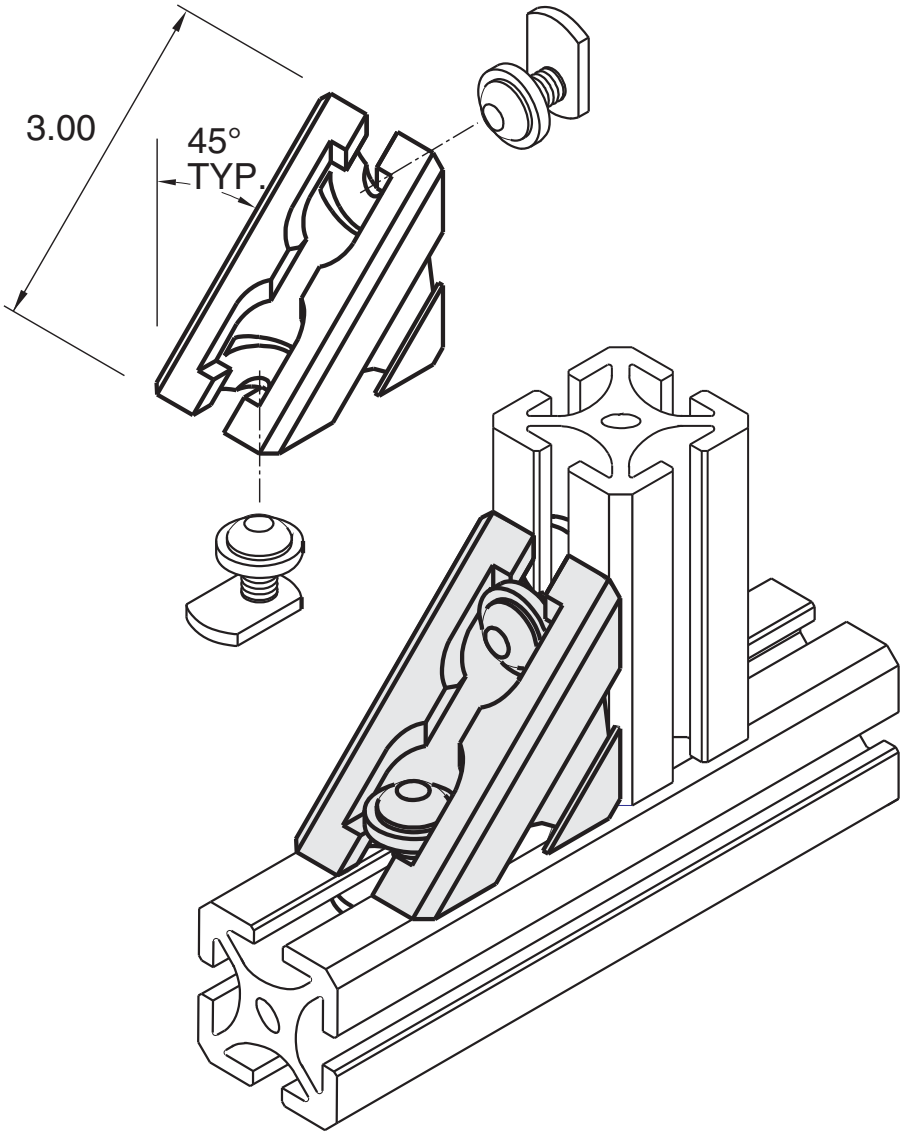

Hardware included

Material - Aluminum (EX-1)  
Finish - Clear Anodize

**5/16" SLOTS**

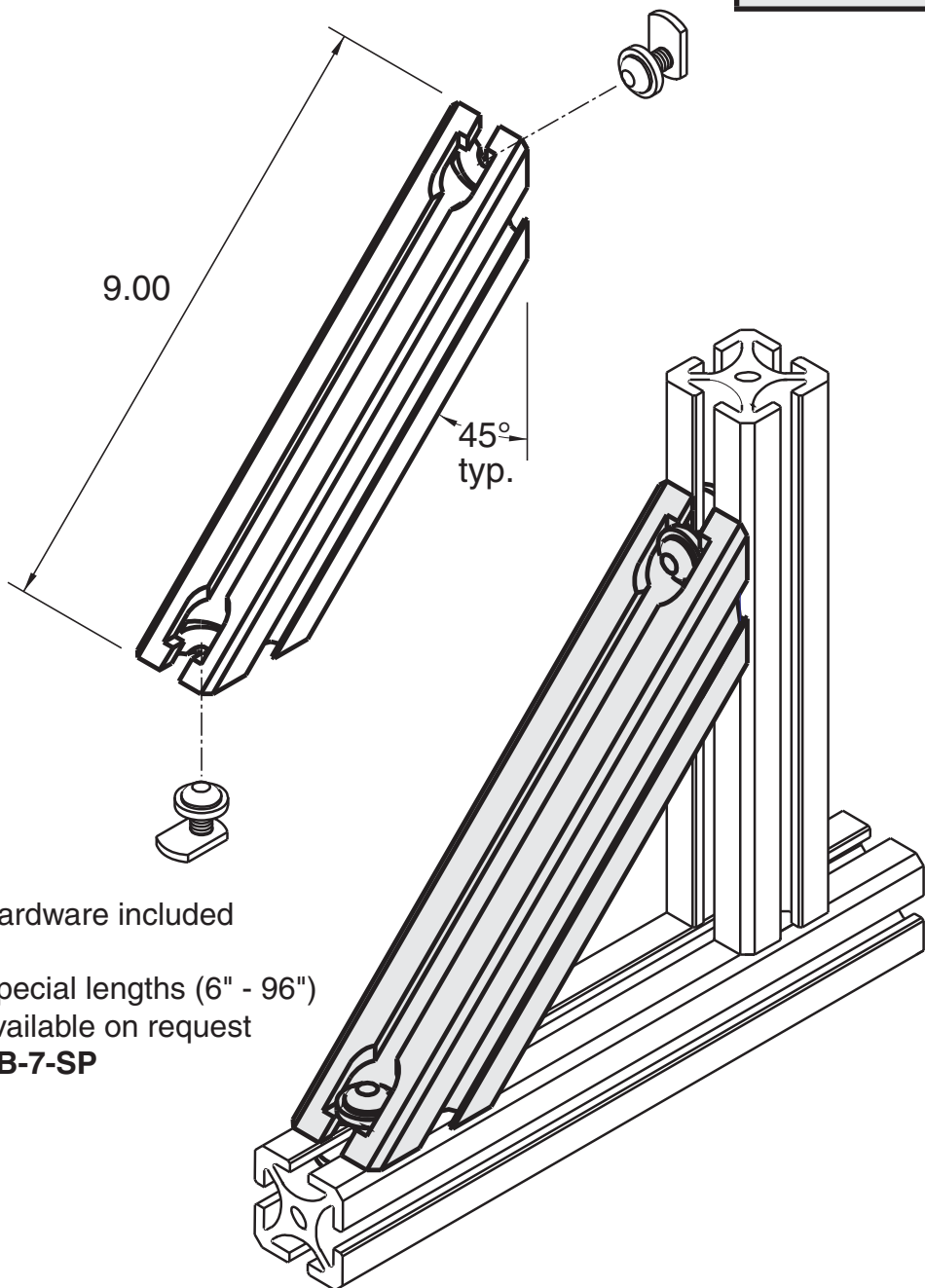

Hardware included

Special lengths (6" - 96")  
available on request  
**EB-7-SP**

Material - Aluminum (EX-1)  
Finish - Clear Anodize

<b>EB-36</b>
<b>EB-37</b>

drilled and c'bored  
for EF-11-.63 SHCS

drilled and c'bored  
for EF-11-.75 SHCS

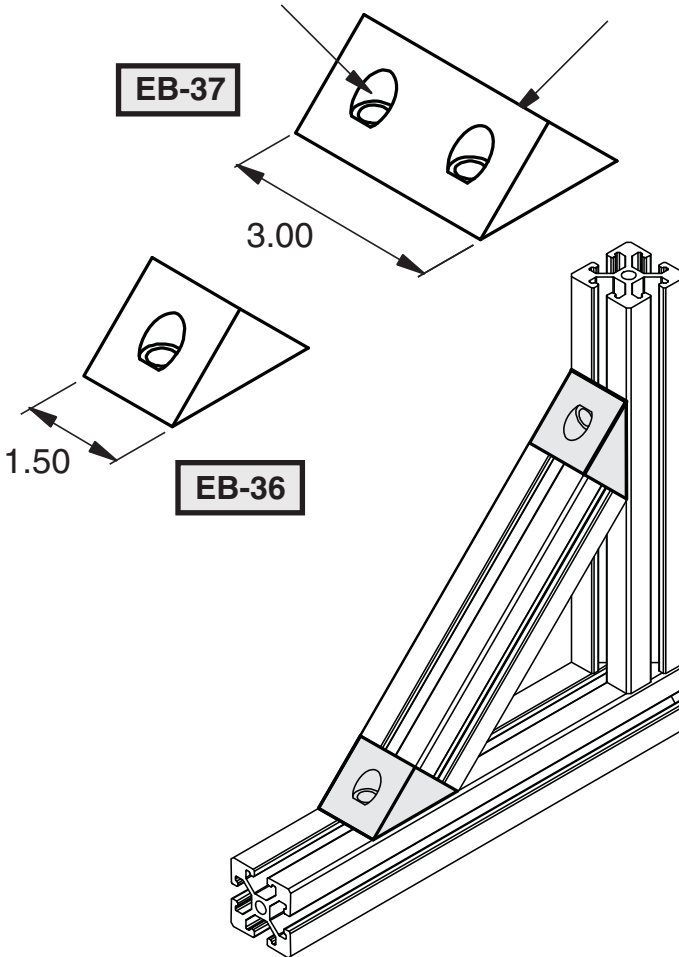

5/16" SLOTS

### EB-36

#### Recommended Hardware

- (1) EF-11-.75 SHCS
- (1) EF-11-.63 SHCS
- (1) EF-2 T-nut

### EB-37

#### Recommended Hardware

- (2) EF-11-.75 SHCS
- (2) EF-11-.63 SHCS
- (2) EF-2 T-nut

Material - Aluminum  
Finish - Clear Anodize

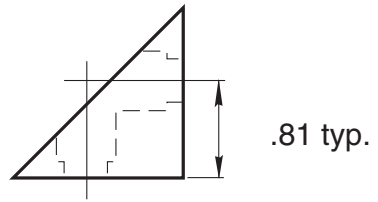
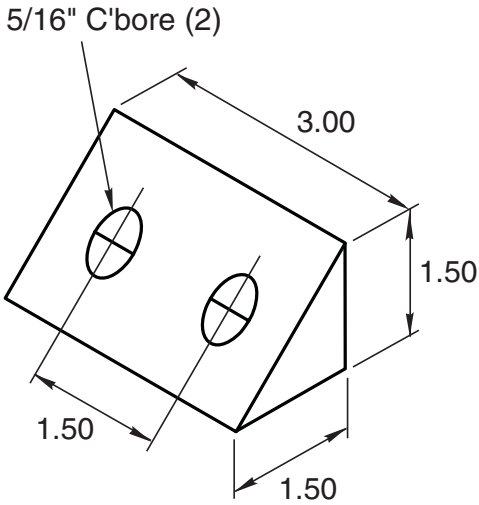

5/16" SLOTS

Recommended Hardware  
(4) EF-11-.63 SHCS  
(4) EF-2 T-nut

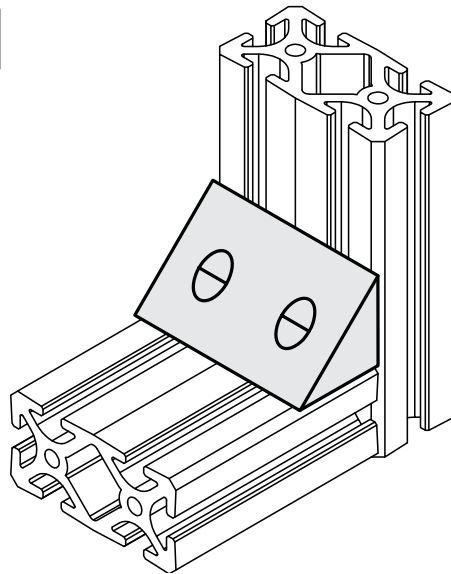

Material - Aluminum  
Finish - Clear Anodize

**Corner Gusset**  
(used with EX-52 and EX-54)



**EB-20**

5/16" SLOTS

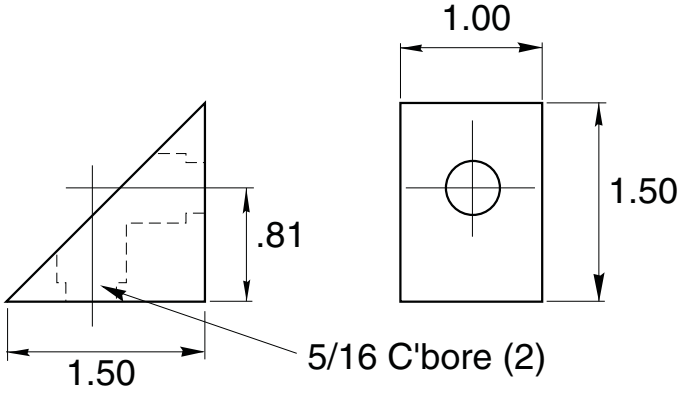

Recommended Hardware  
(4) EF-11-.63 SHCS  
(4) EF-2 T-nut

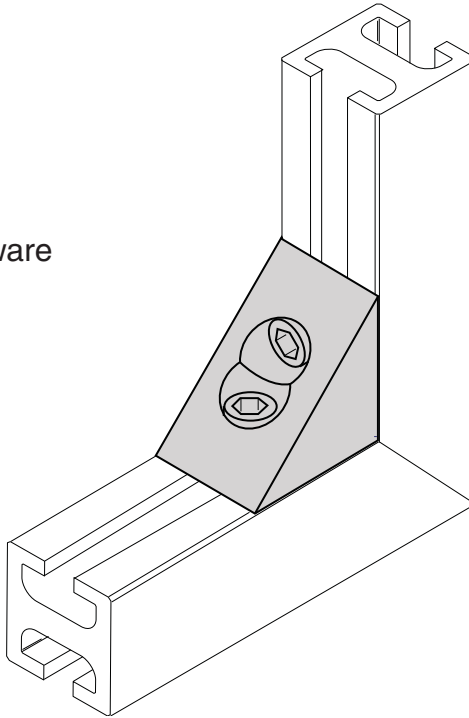

Material - Aluminum  
Finish - Clear Anodize

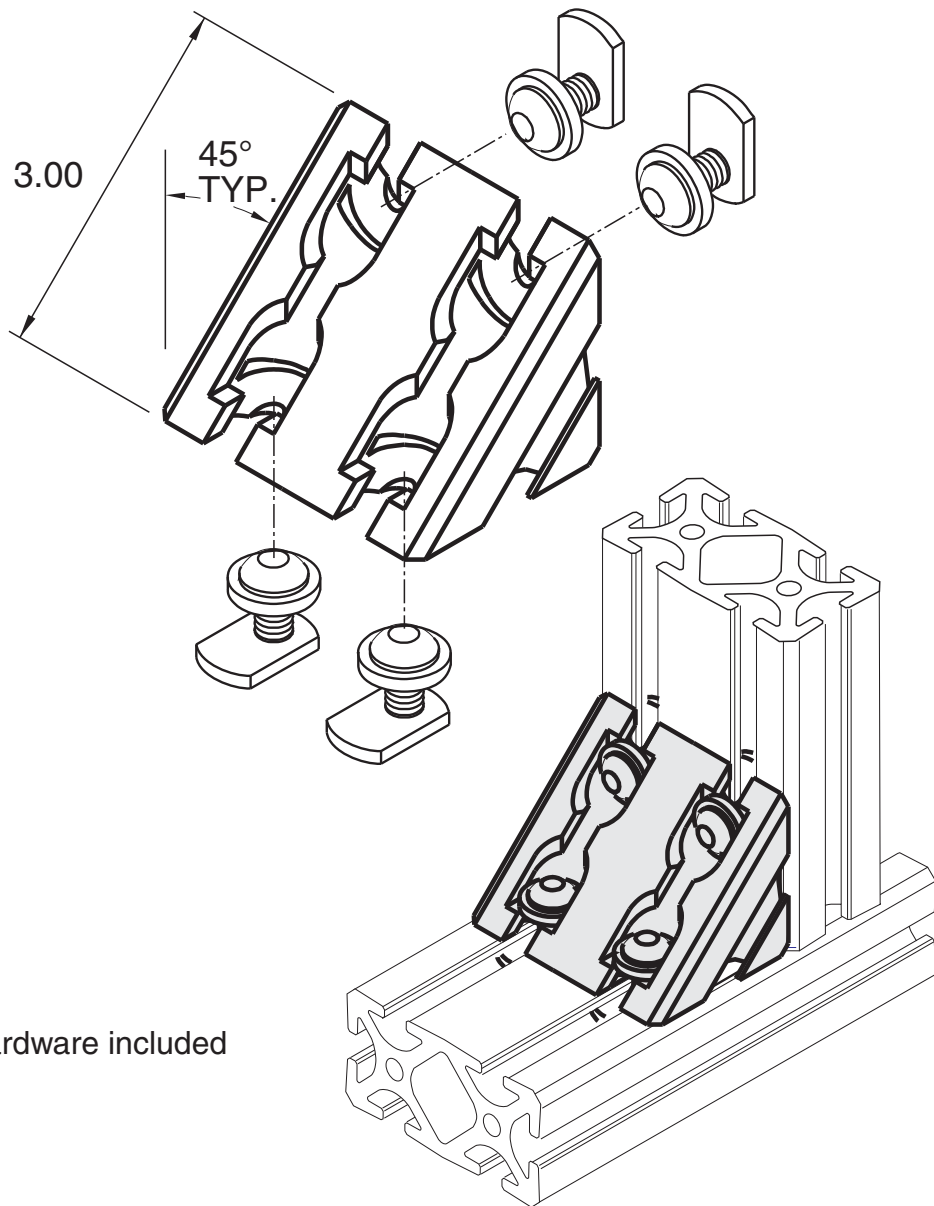

Hardware included

Material - Aluminum (EX-2)  
Finish - Clear Anodize



1.5 x 3.0 Extrusion  
Corner Gusset



**EB-9**

**5/16" SLOTS**

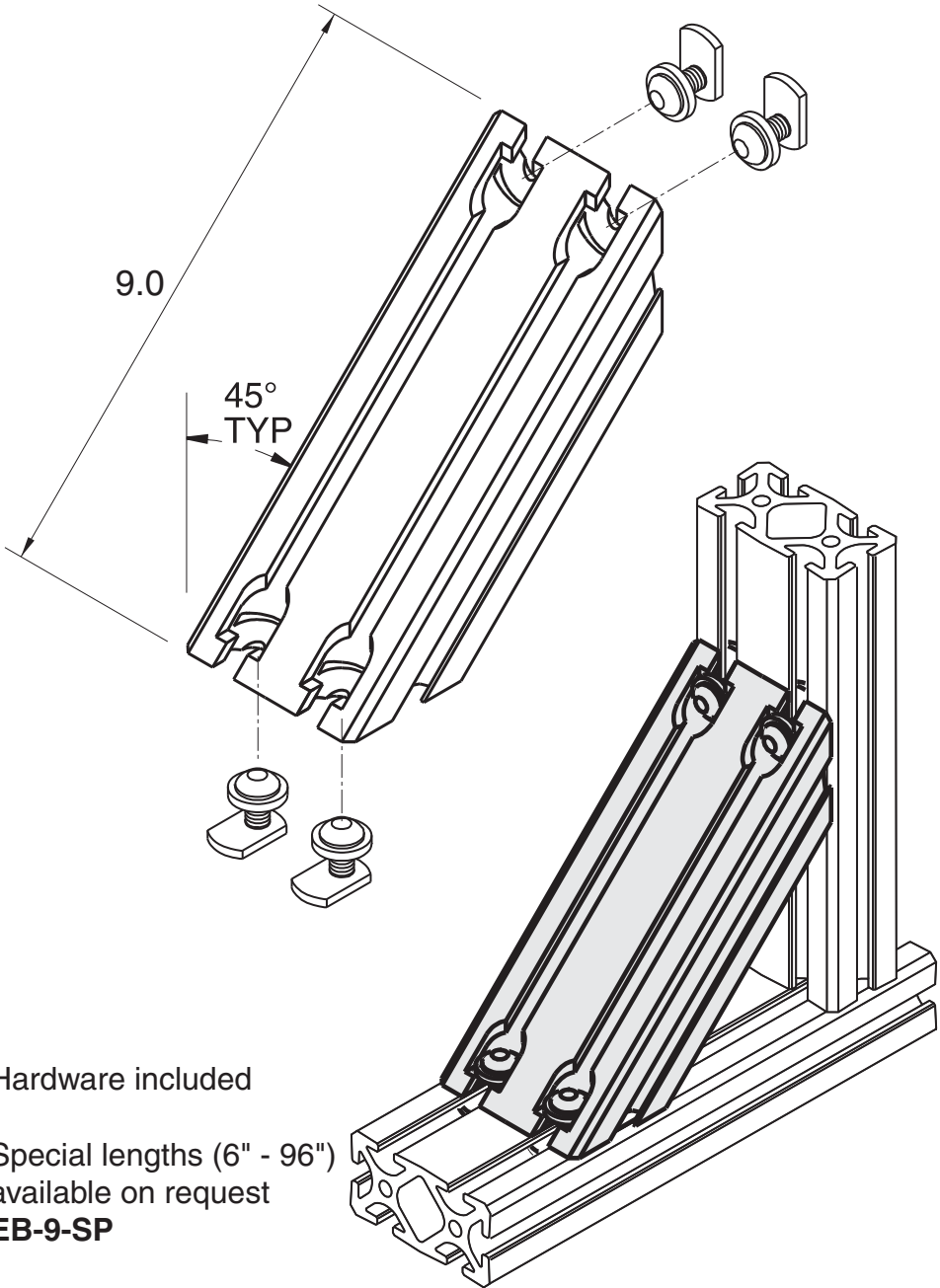

Hardware included

Special lengths (6" - 96")  
available on request  
**EB-9-SP**

Material - Aluminum (EX-2)  
Finish - Clear Anodize

**EB-10**

Slotted

**EB-10A**

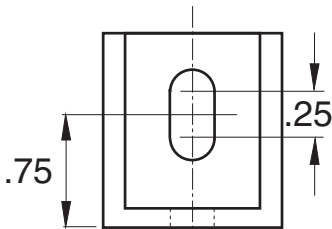
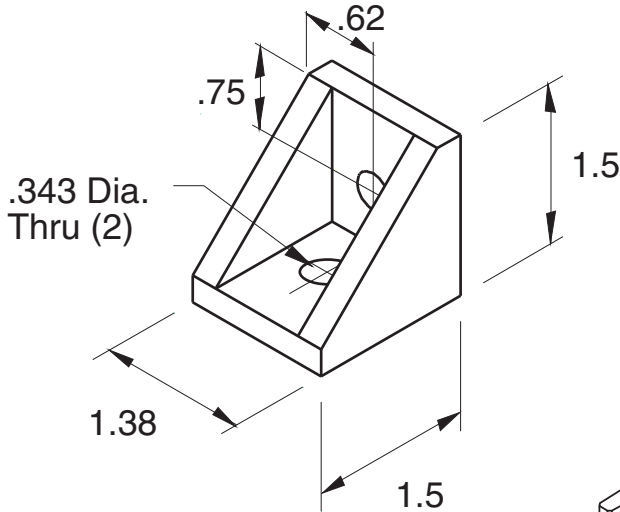

**EB-10A  
(1) hole  
slotted**

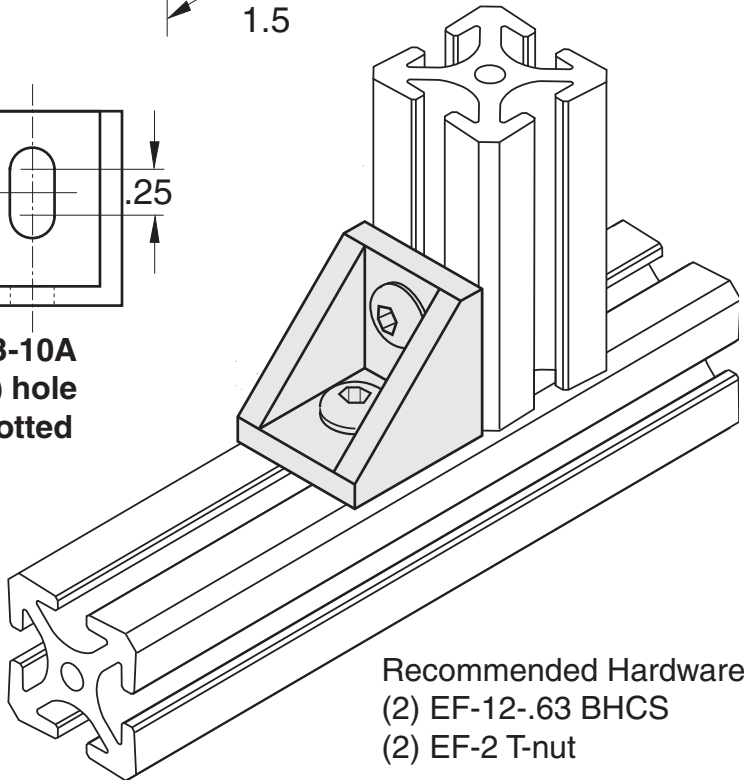

**Recommended Hardware**  
(2) EF-12-.63 BHCS  
(2) EF-2 T-nut

**Material - Aluminum**  
**Finish - Grey Powder Coat**

**5/16" SLOTS**

**EB-11**

**5/16" SLOTS**

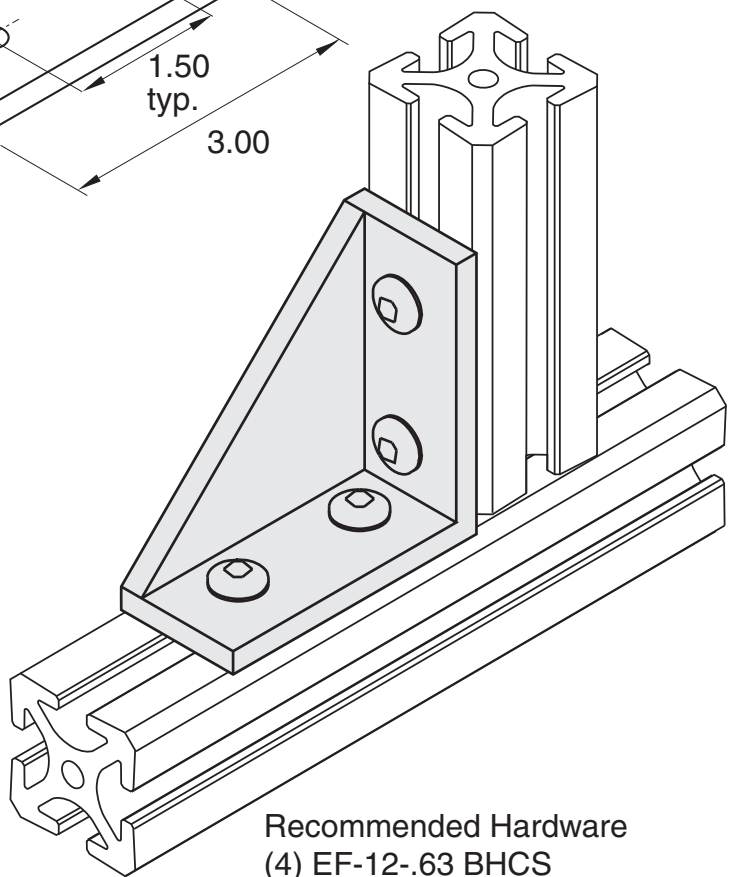
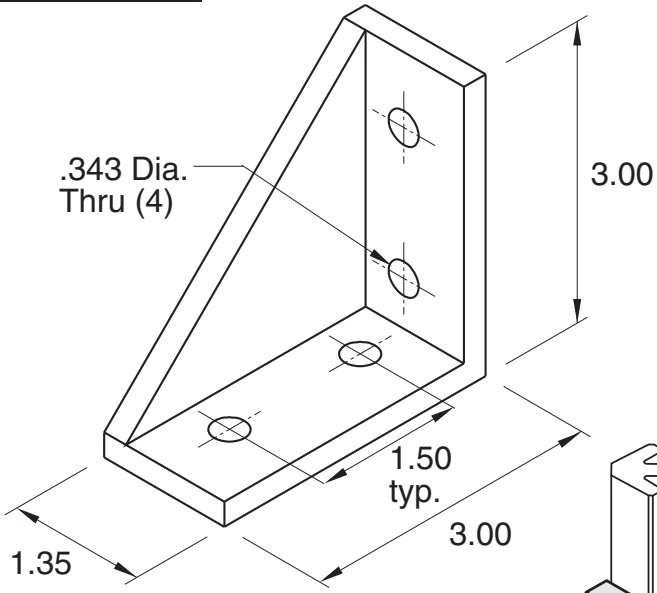

Recommended Hardware  
(4) EF-12-.63 BHCS  
(4) EF-2 T-nut

Material - Aluminum  
Finish - Grey Powder Coat

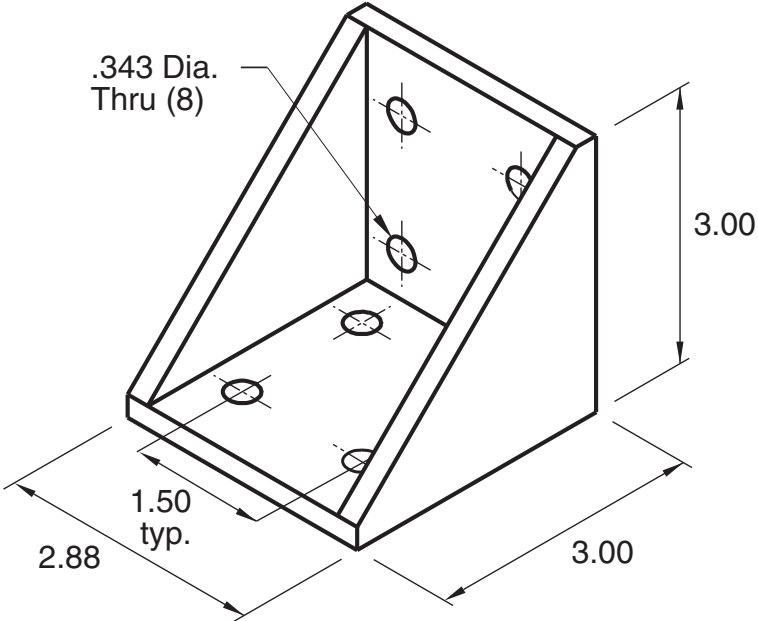

5/16" SLOTS

Recommended Hardware  
(8) EF-12-.63 BHCS  
(8) EF-2 T-nut

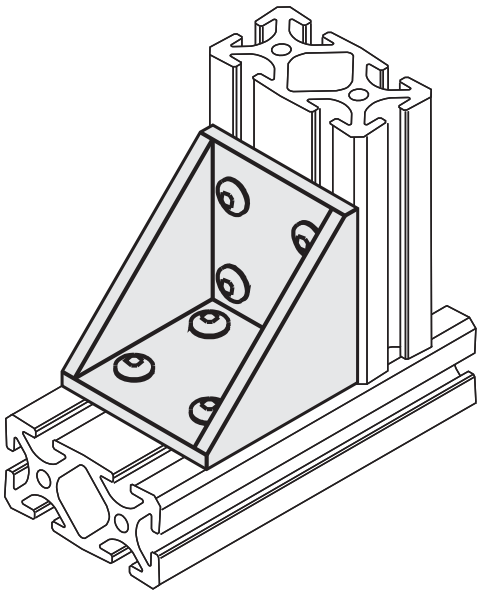

Material - Aluminum  
Finish - Grey Powder Coat

**EB-17**

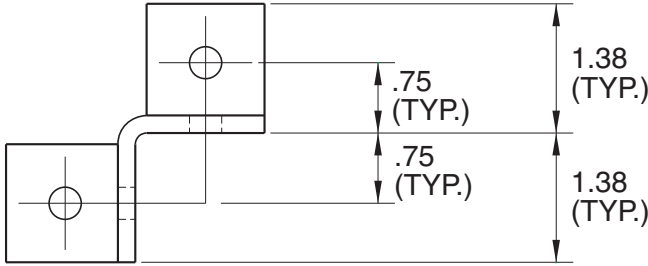

.343 Dia.  
Thru (4)

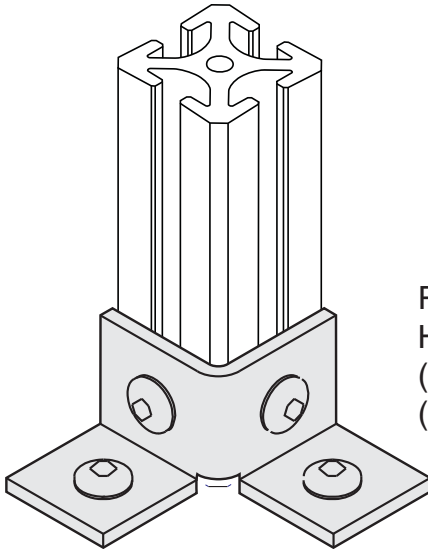
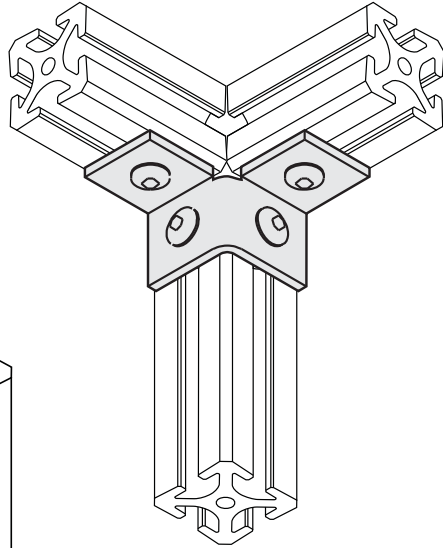
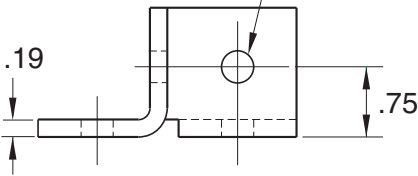

Recommended  
Hardware  
(4) EF-12-.63 BHCS  
(4) EF-2 T-nut

Material - Steel  
Finish - Zinc Plated

5/16" SLOTS

**EB-16**

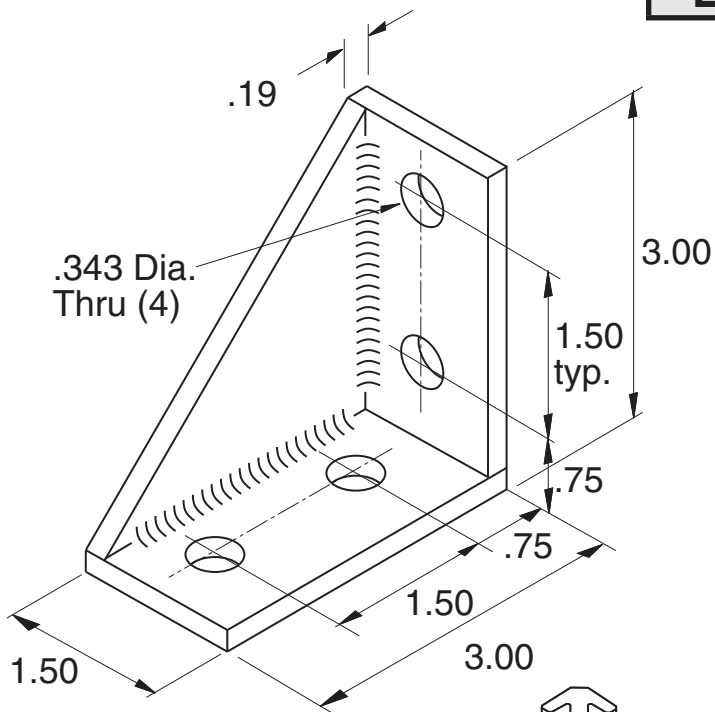

**5/16" SLOTS**

Recommended  
Hardware  
(4) EF-12-.63 BHCS  
(4) EF-2 T-nut

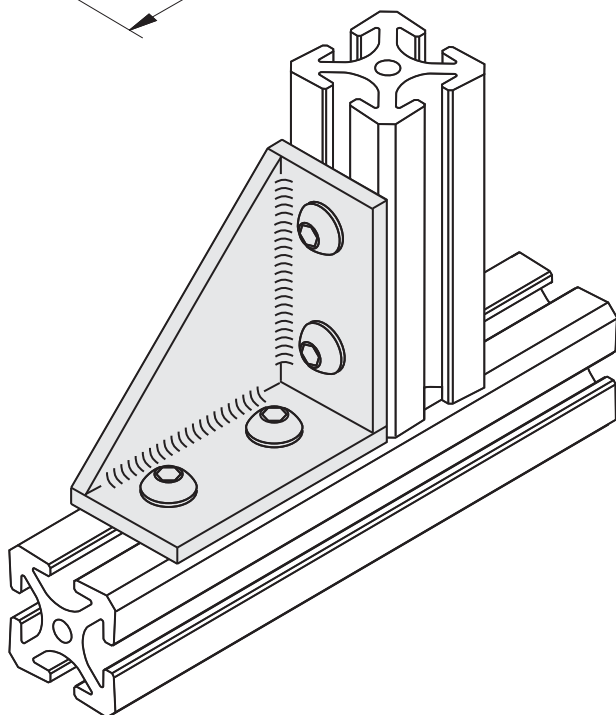

**Material - Steel**  
**Finish - Black Powder Coat**

**EB-15P**

5/16" SLOTS

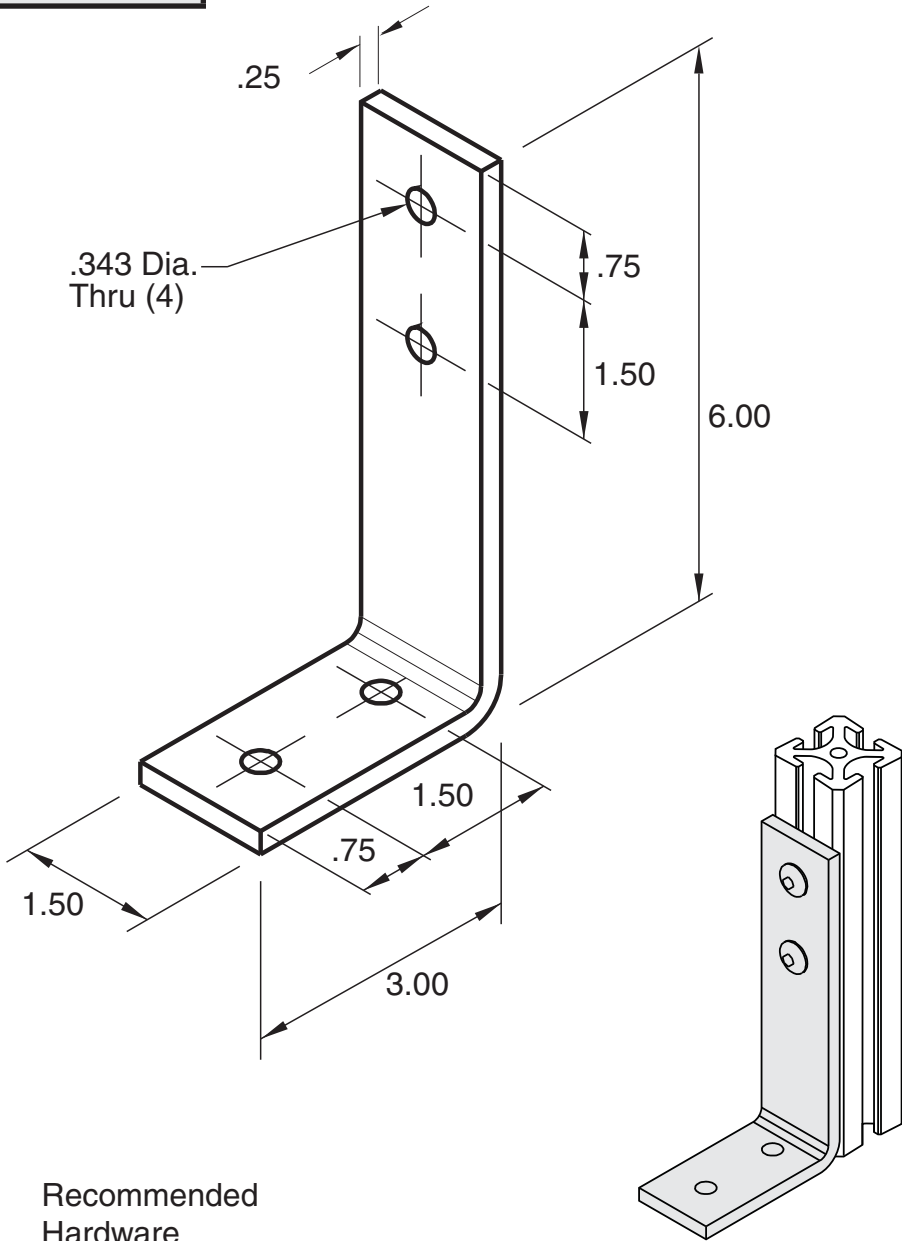

Recommended Hardware  
(4) EF-12-.63 BHCS  
(4) EF-2 T-nut

Material - Steel  
Finish - Black Powder Coat

**EB-15LH (left hand )  
EB-15RH (right hand )**

**EB-15**

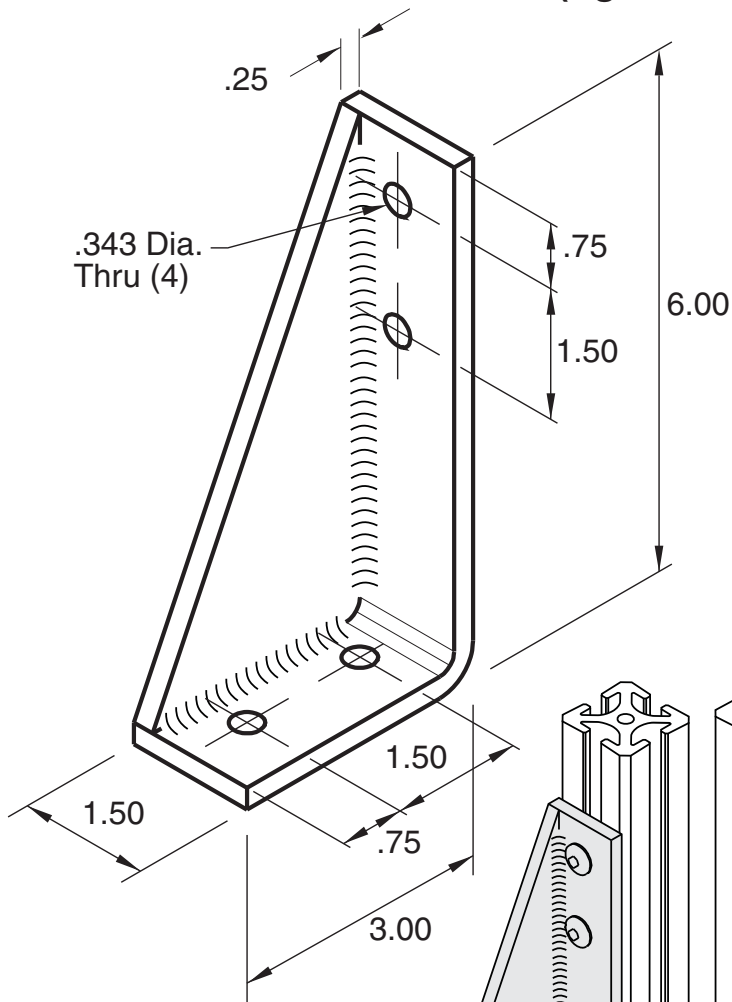

5/16" SLOTS

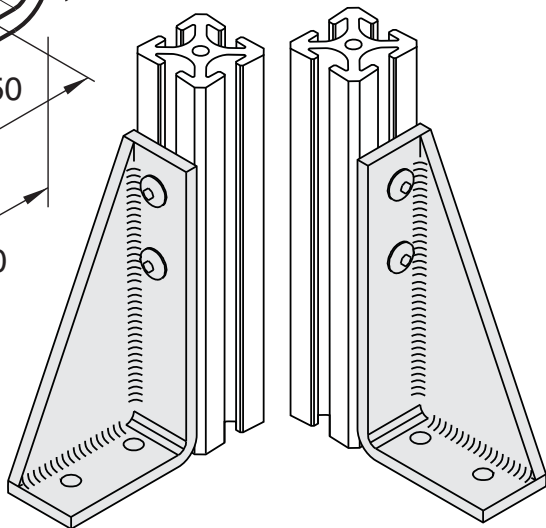

**EB-15LH  
(left hand)**

**EB-15RH  
(right hand)**

Recommended  
Hardware  
(4) EF-12-.63 BHCS  
(4) EF-2 T-nut

Material - Steel  
Finish - Black Powder Coat



**EB-14P**

5/16" SLOTS

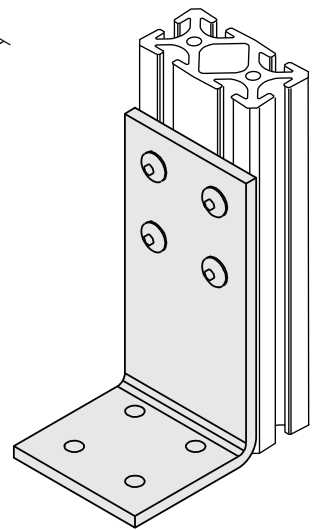
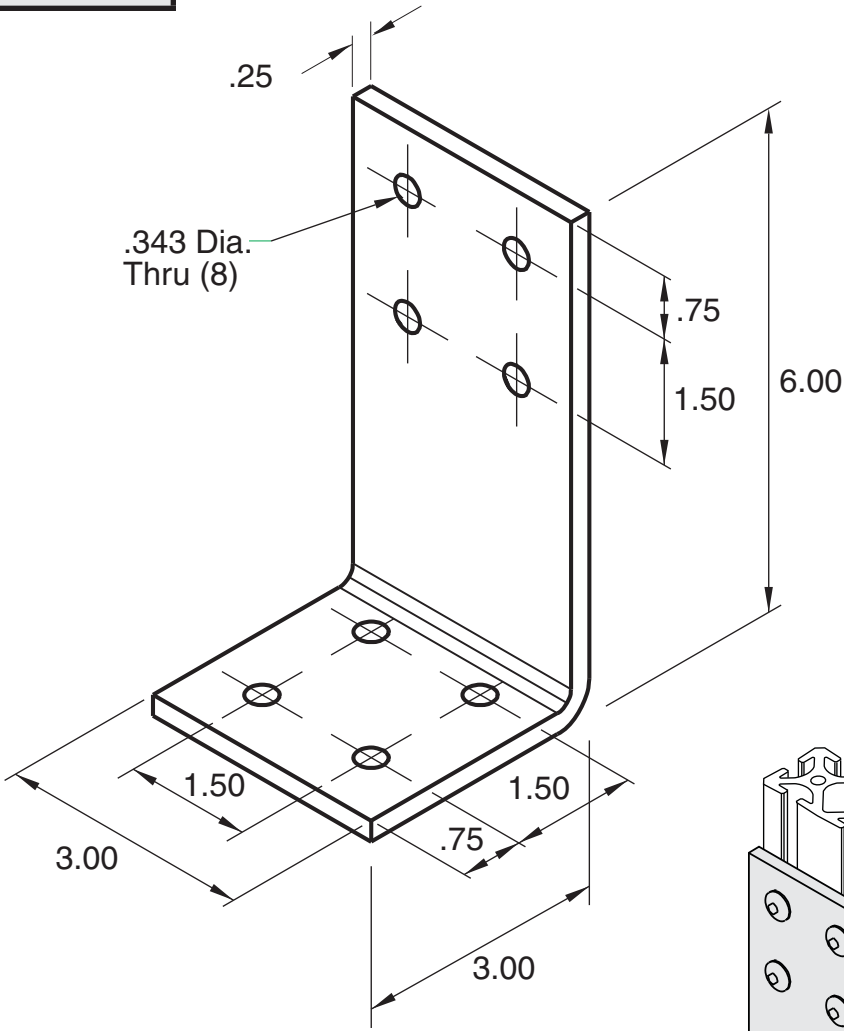

Recommended Hardware  
(8) EF-12-.63 BHCS  
(8) EF-2 T-nut

Material - Steel  
Finish - Black Powder Coat

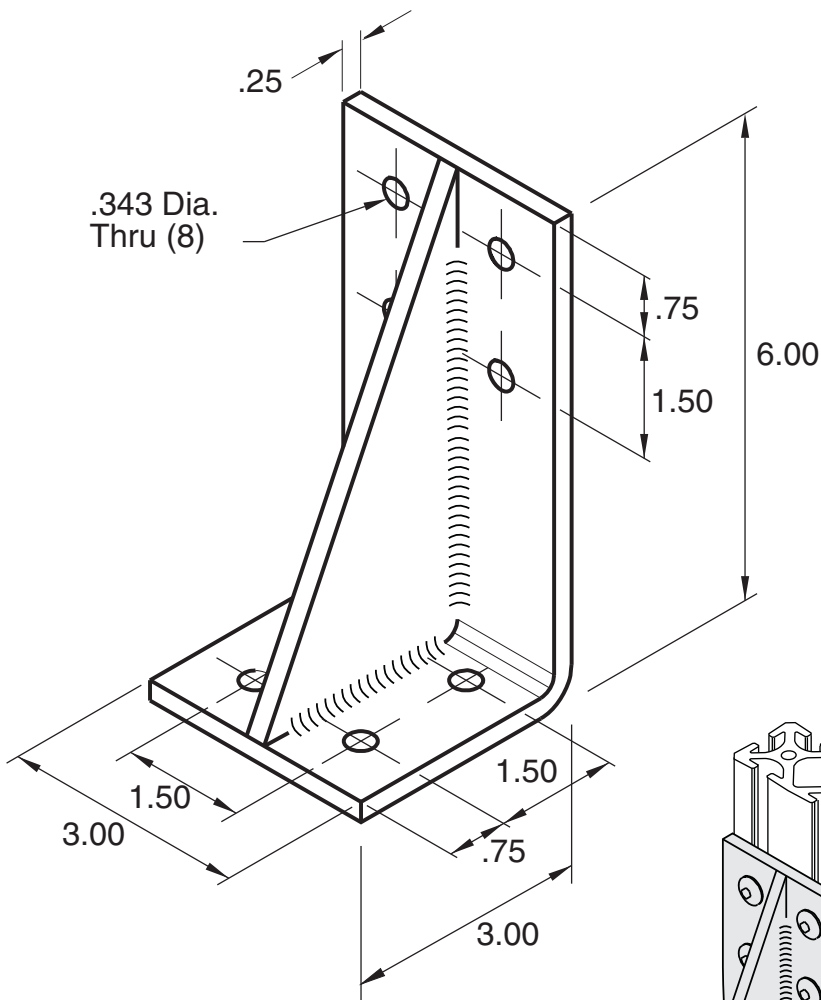

**5/16" SLOTS**

Recommended  
Hardware  
(8) EF-12-.63 BHCS  
(8) EF-2 T-nut

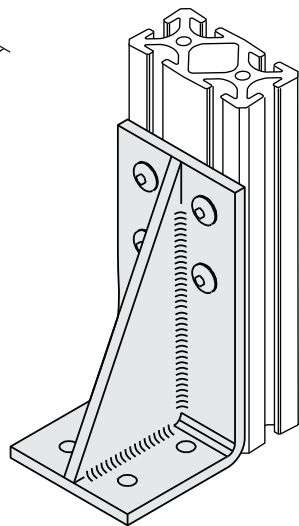

Material - Steel  
Finish - Black Powder Coat

<b>EF-62</b>	with hardware
<b>EF-62P</b>	without hardware
<b>EF-62M</b>	with metric hardware
<b>EF-62SS</b>	with stainless steel bolt

5/16" SLOTS

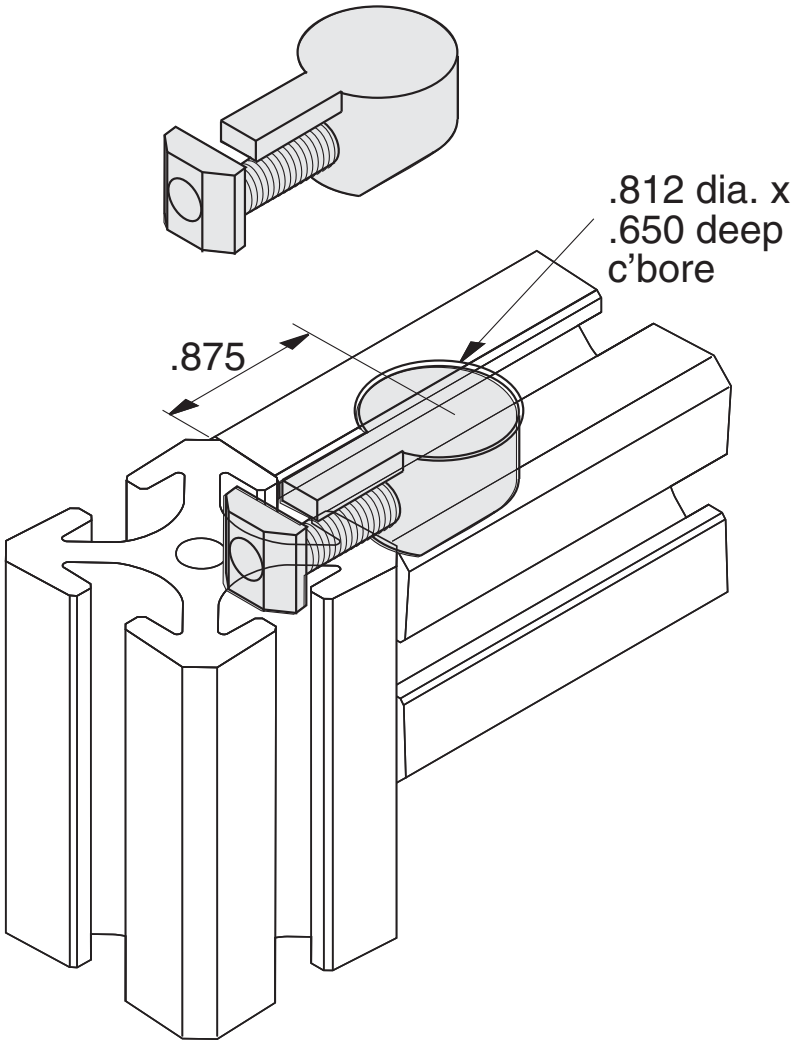

**Material:**  
Anchor - Cast Zinc, Zinc Plated  
Bolt - Steel, Black Oxide Coating  
T-nut - Steel Zinc Coated

X = 1.50 in.	<b>EF-63</b>
X = 1.50 in. with metric hardware	<b>EF-63M</b>
X = 1.50 in. with stainless steel bolt	<b>EF-63SS</b>
X = 3.0 in.	<b>EF-64</b>
X = 3.0 in. with metric hardware	<b>EF-64M</b>
X = 3.0 in. with stainless steel bolt	<b>EF-64SS</b>

**5/16" SLOTS**

All Hardware Included

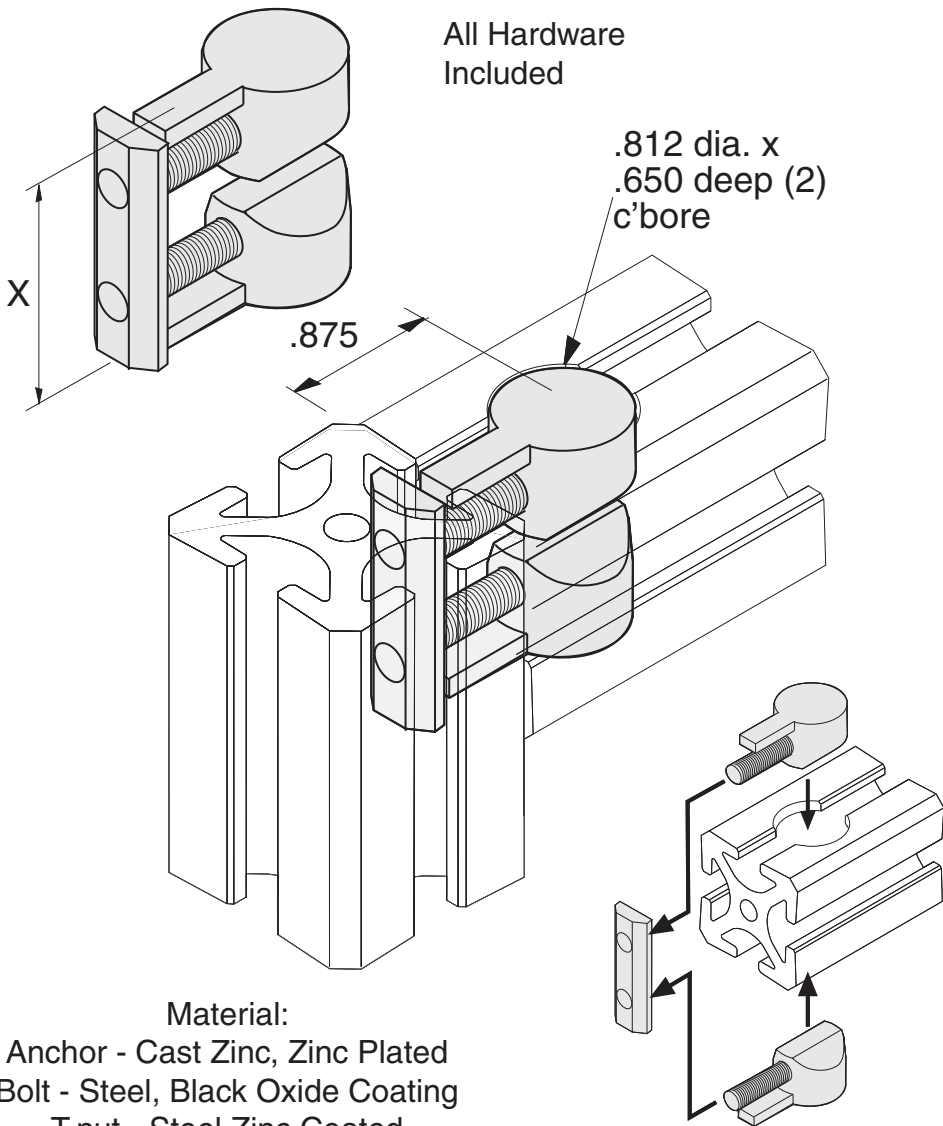

**Material:**  
 Anchor - Cast Zinc, Zinc Plated  
 Bolt - Steel, Black Oxide Coating  
 T-nut - Steel Zinc Coated

# Anchor Butt Fastener



<b>EF-61</b>
<b>EF-61M</b>
<b>EF-61SS</b>

with metric hardware

with stainless steel bolt

All Hardware  
Included

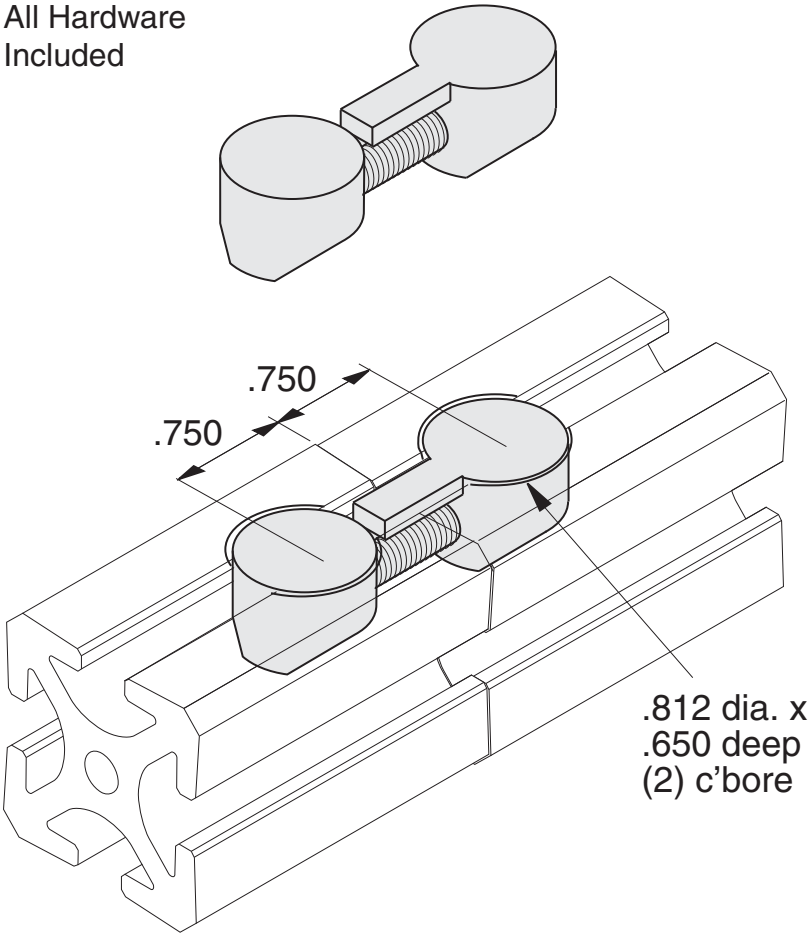

### Material:

Anchor - Cast Zinc, Zinc Plated  
Bolt - Steel, Black Oxide Coating  
T-nut - Steel Zinc Coated

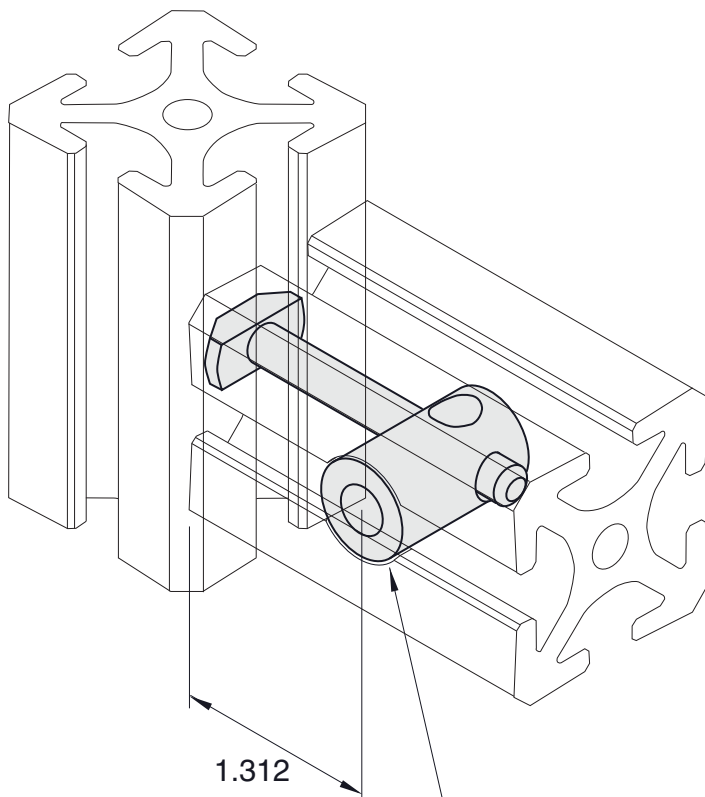
**5/16" SLOTS****DRILL  $\varnothing$  5/8" X 1.00 DEEP**

Hardware Included

Use with 5/16" Slot Extrusions Only

**Material**

Anchor - Cold Rolled Steel

Bolt - Cold Rolled Steel

Set Screw - Steel, Black Oxide Coating

# Plate Connector



<b>EF-100</b>
<b>EF-100M</b>

hardware included

metric hardware included

5/16" SLOTS

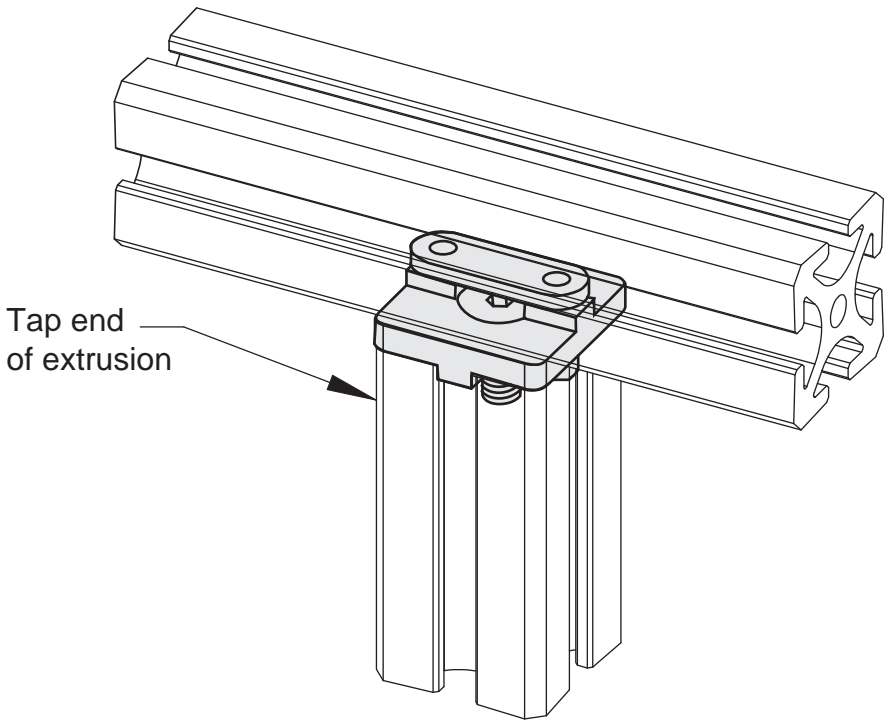
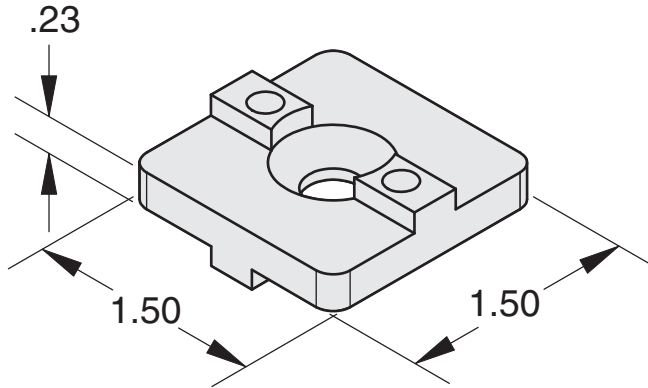

Material - Cast Zinc  
Finish - Zinc Plated

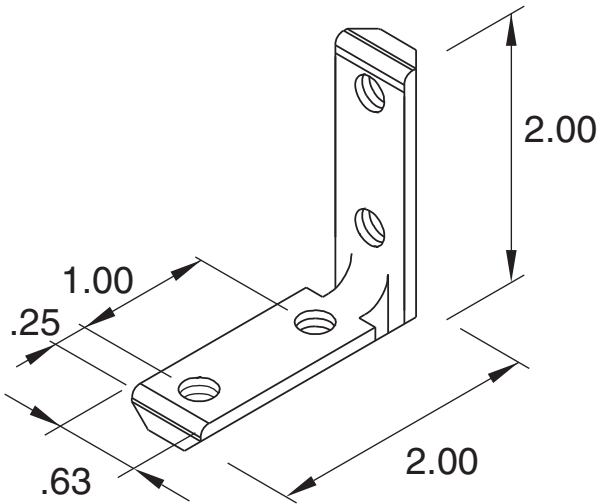

Hardware  
Included

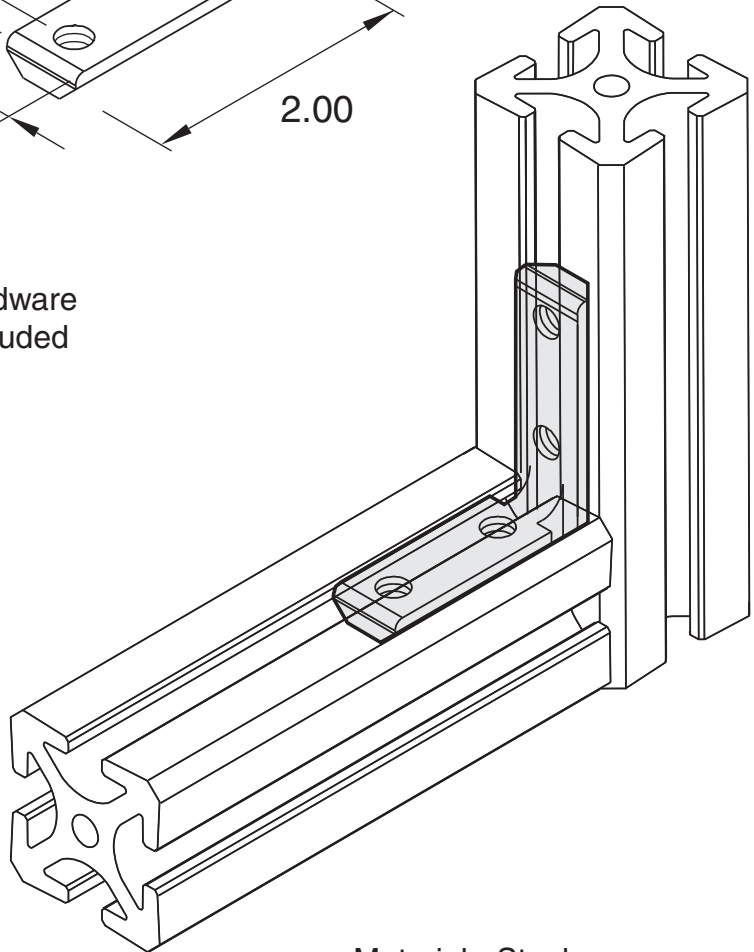

**5/16" SLOTS**

Material - Steel  
Finish - Zinc Plated



# Internal Corner Bracket



**EF-27A** use with EX-52 and EX-54

Hardware  
Included

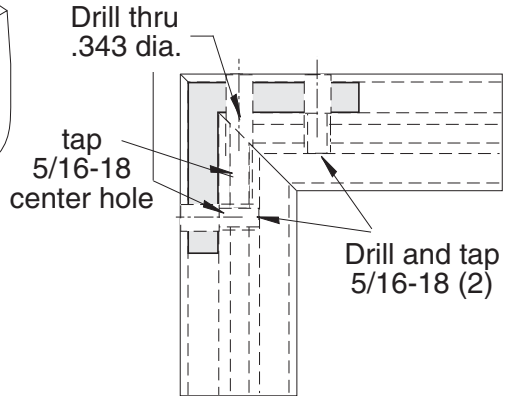
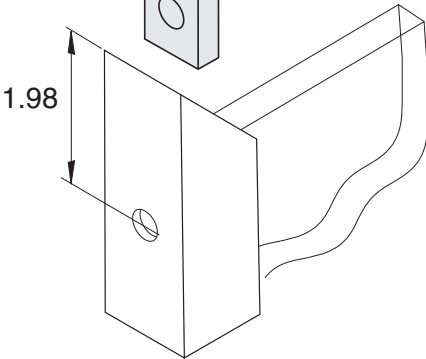
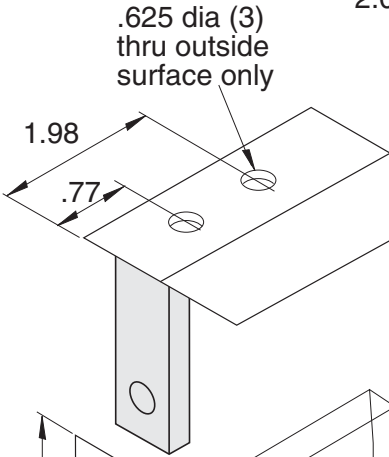
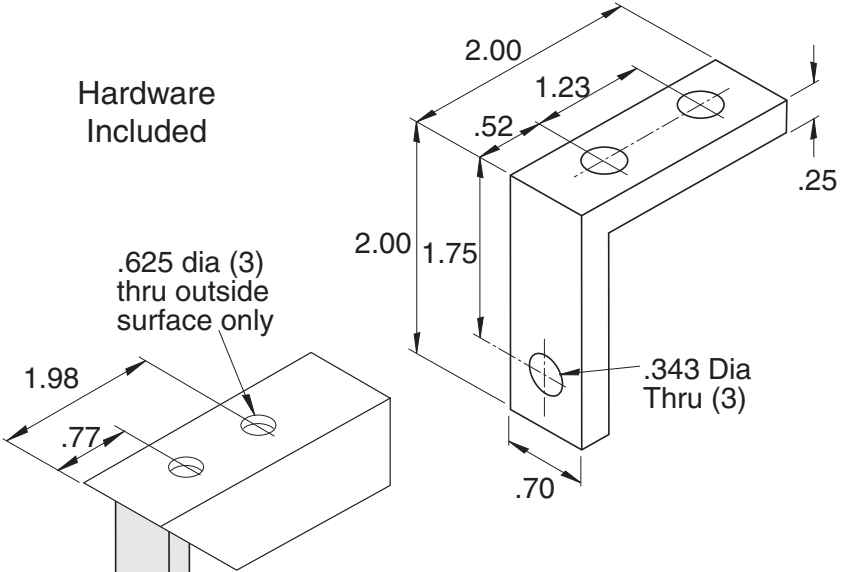

Note: This is the strongest door corner available anywhere.

Material - Steel  
Finish - Zinc Plated

5/16" SLOTS

zinc plated steel

**EF-29**

stainless steel

**EF-SS29**

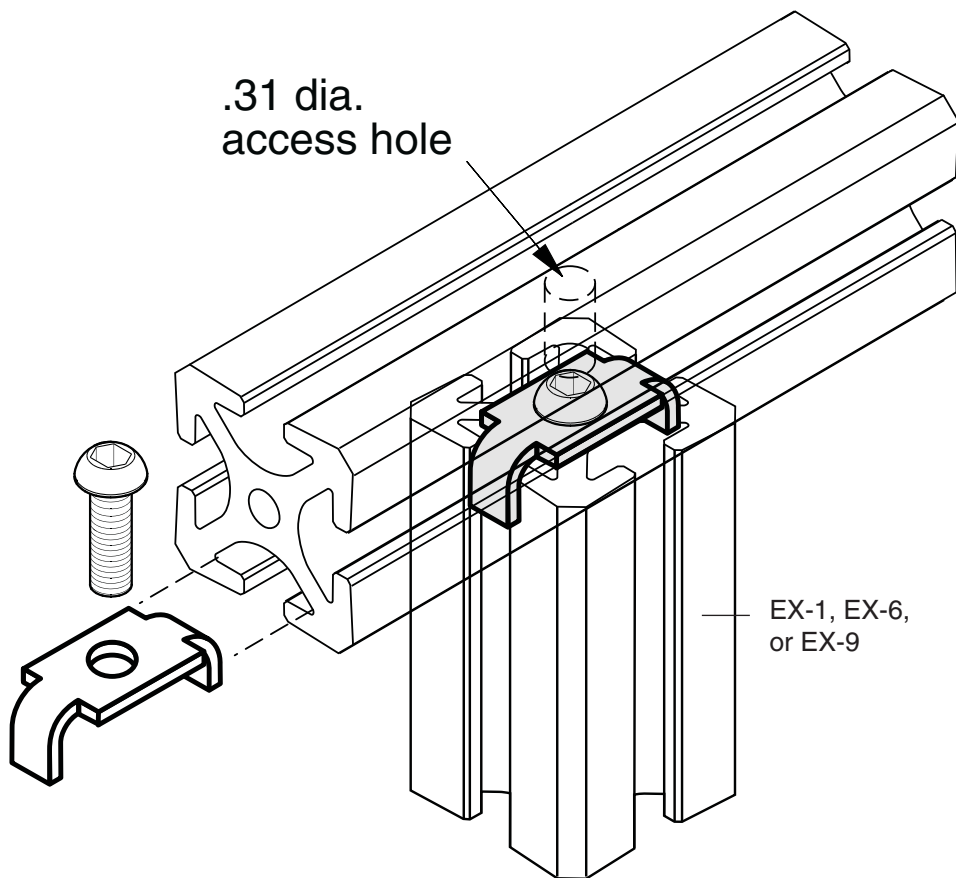

Requires (1) EF-12-1.0 BHCS

# Universal Connector



<b>EF-29A</b>	zinc plated steel
<b>EF-SS29A</b>	stainless steel

5/16" SLOTS

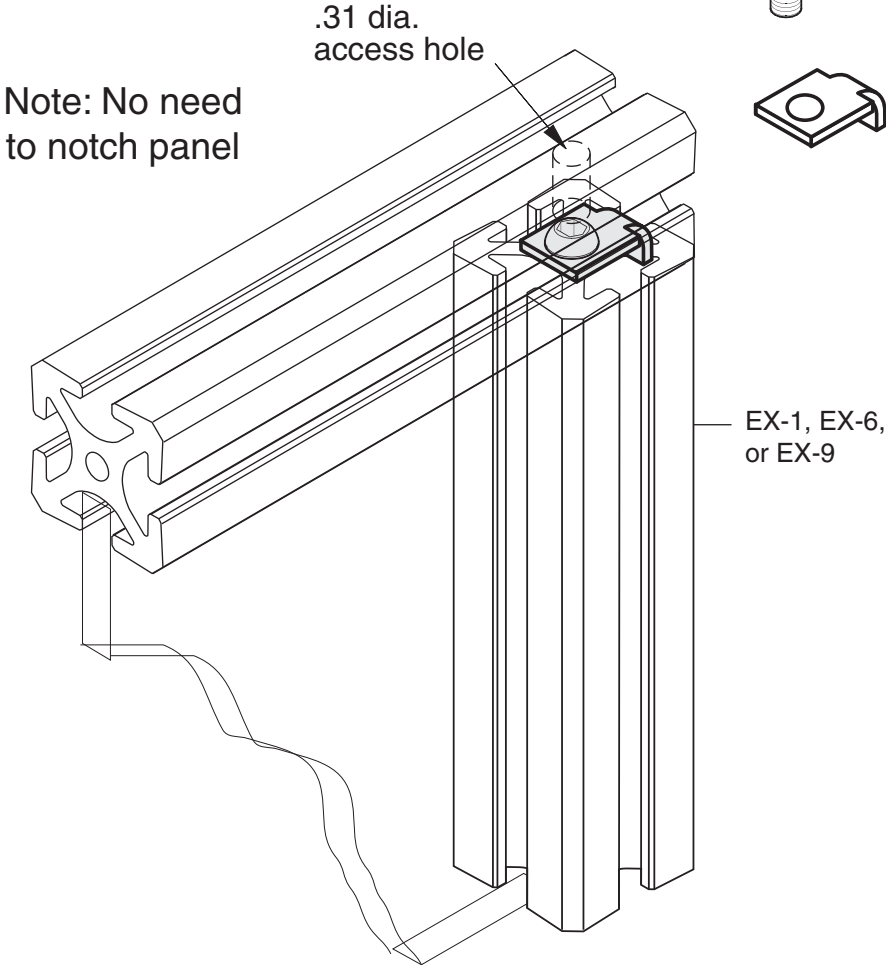

Requires (1) EF-12-1.0 BHCS

Use with *SMOOTH-Series* profiles  
EX-52, EX-54, EX-61, EX-63, EX-64, EX-65

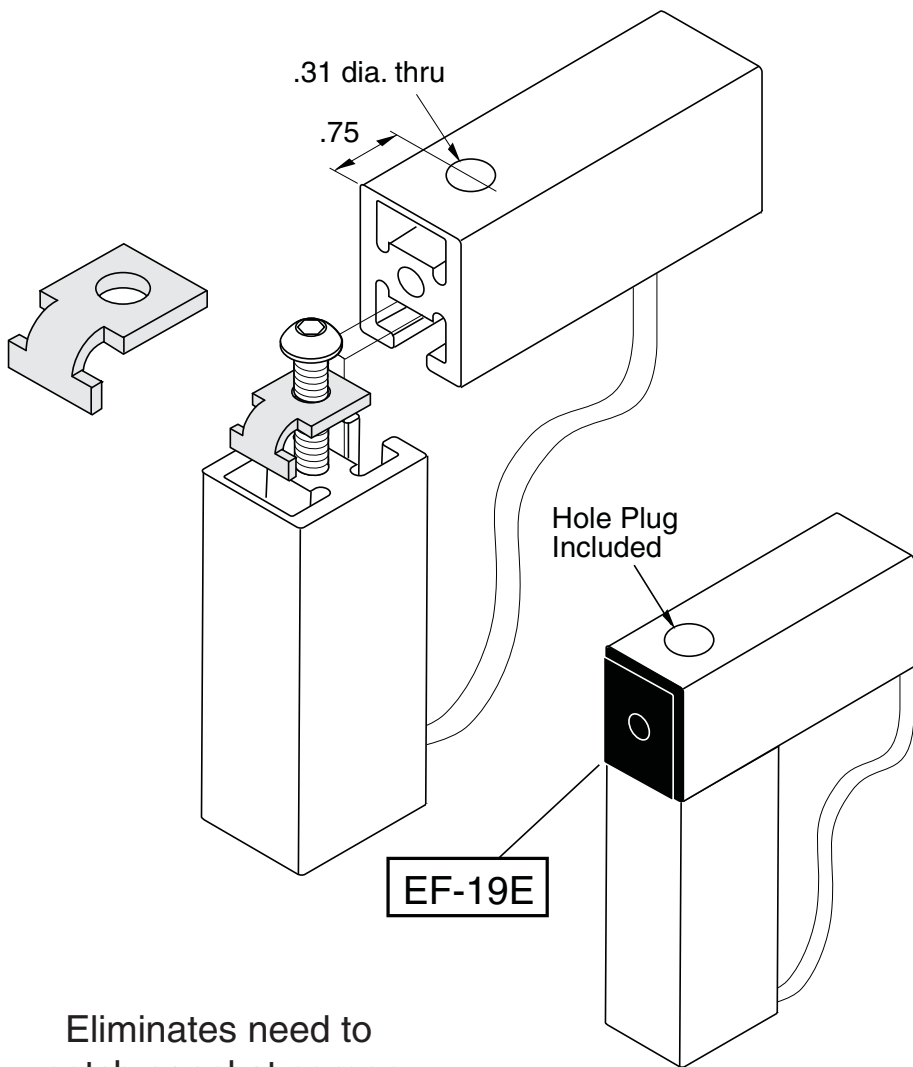
**EF-29B****5/16" SLOTS**

Eliminates need to  
notch panel at corner

Requires (1) EF-12-1.0 BHCS

Material - Steel  
Finish - Zinc Plated

# Double Universal Connector



**EF-29D** .33 wide slot

5/16" SLOTS

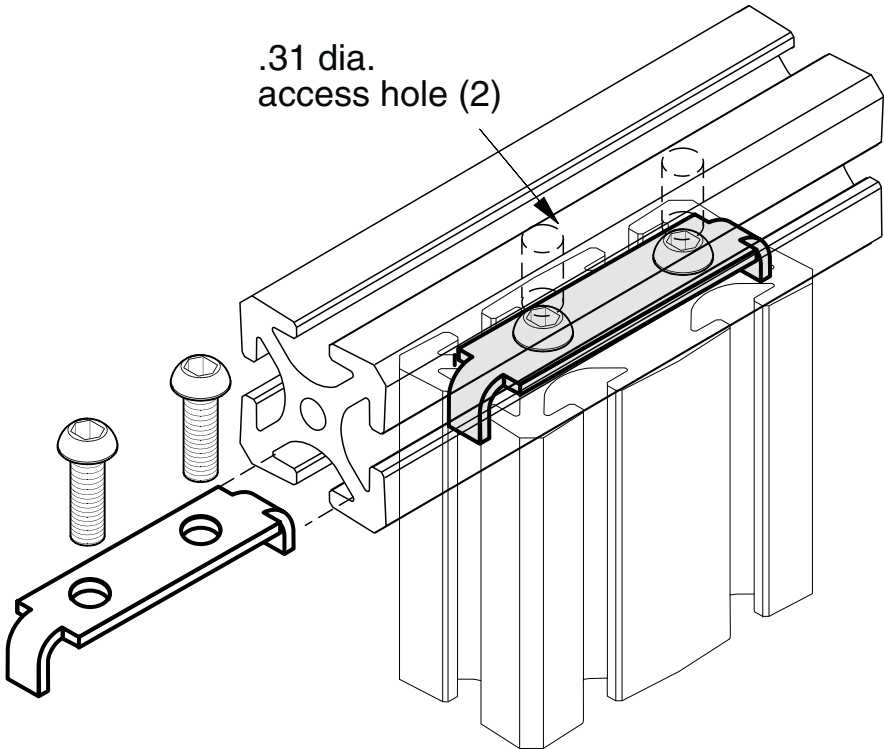

Requires (2) EF-12-1.0 BHCS

Material - Steel  
Finish - Zinc Plated

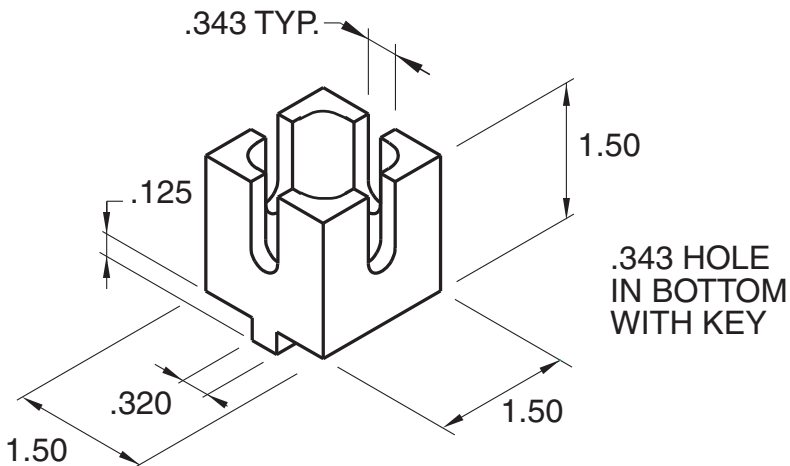

5/16" SLOTS

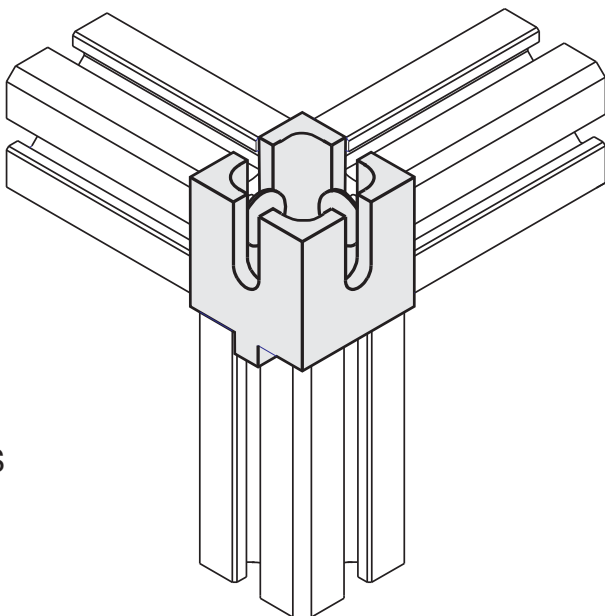

Requires  
(3) EF-12-.75 BHCS

Material - Aluminum  
Finish - Clear Anodize

**ECC-A**

5/16" SLOTS

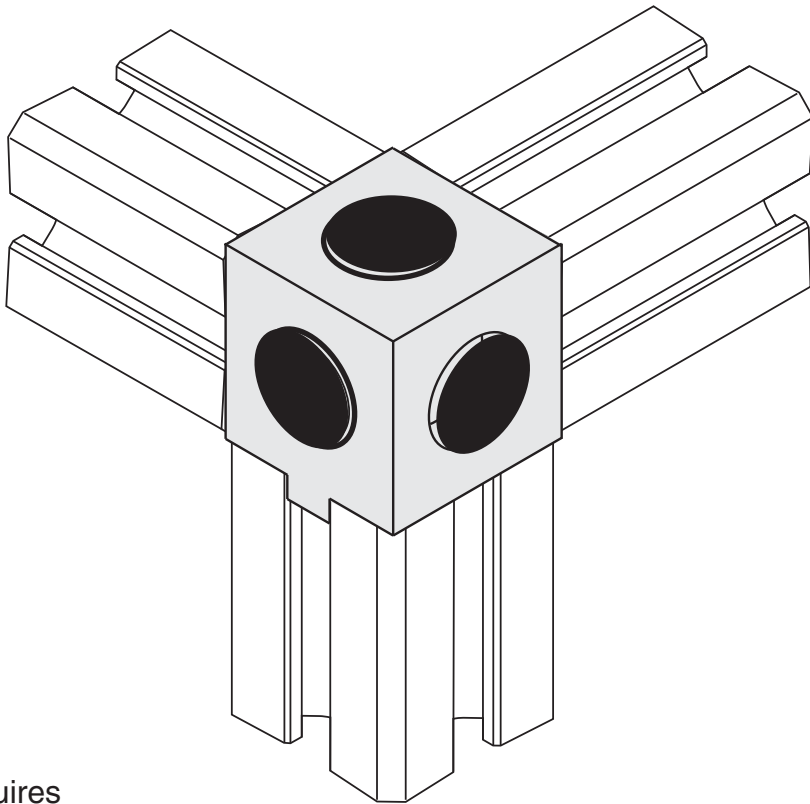

Requires  
(3) EF-12-.75 BHCS

Hole plugs included

Material - Aluminum  
Finish - Clear Anodize

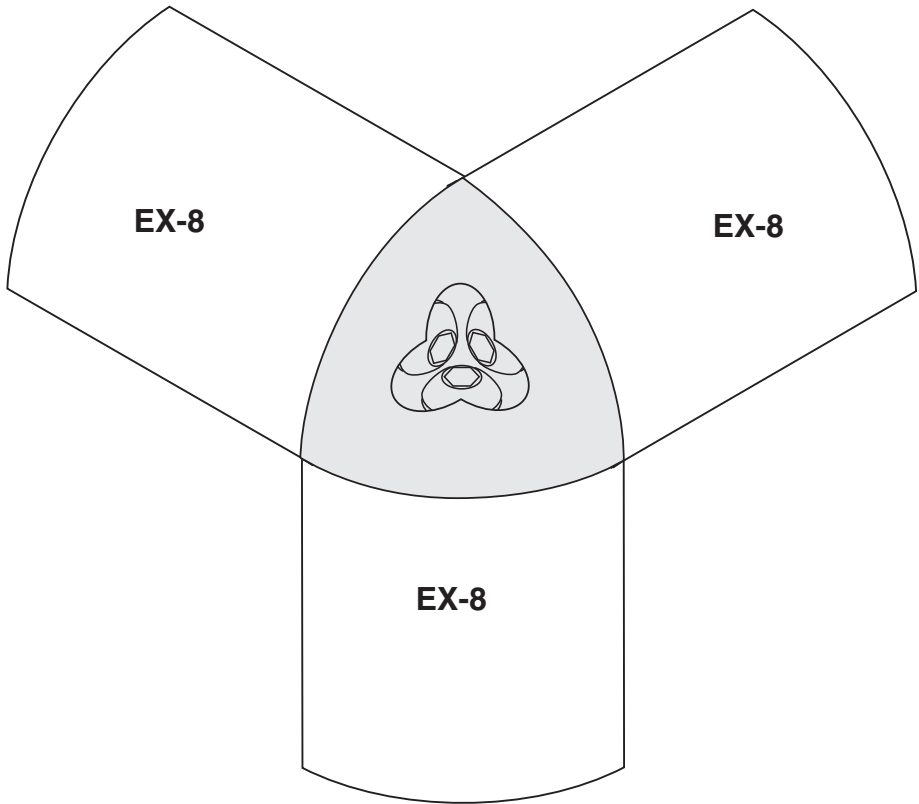

**5/16" SLOTS**

Hardware Included

Material - Aluminum  
Finish - Clear Anodize



**EB-86**

5/16" SLOTS

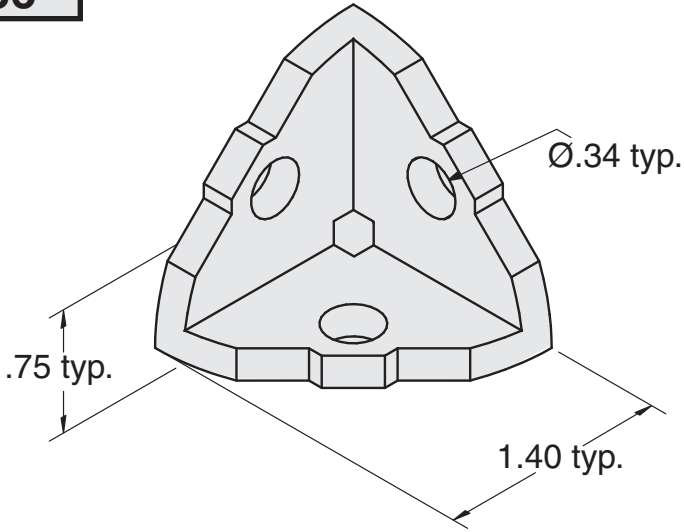

Hardware Included

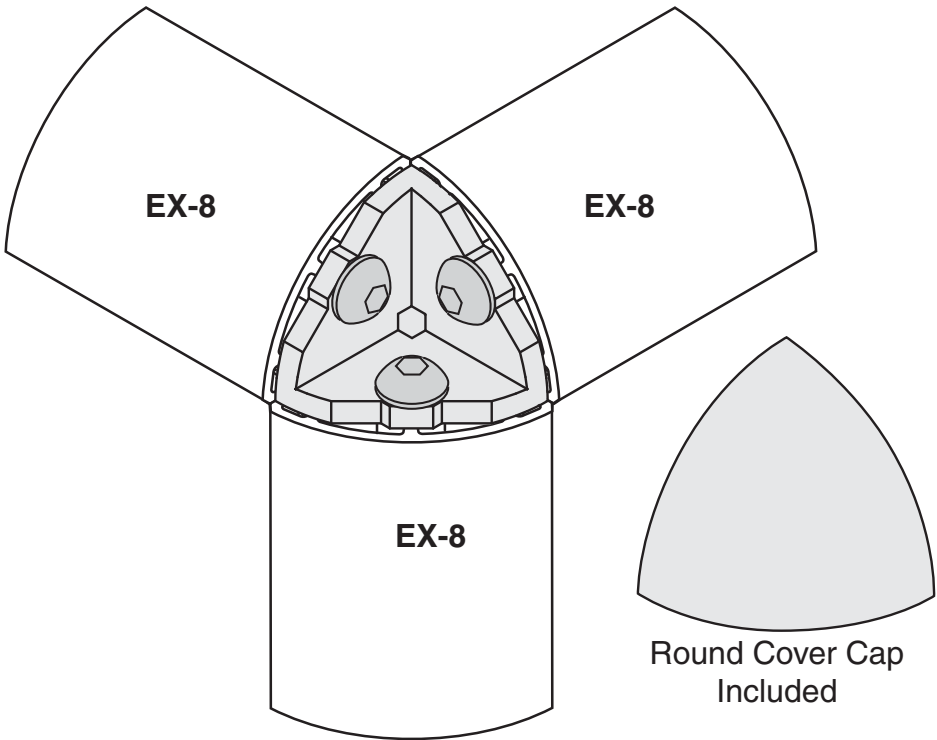

Material -Bracket: Die Cast Zinc  
Cap: Reinforced Nylon

**5/16" SLOTS**

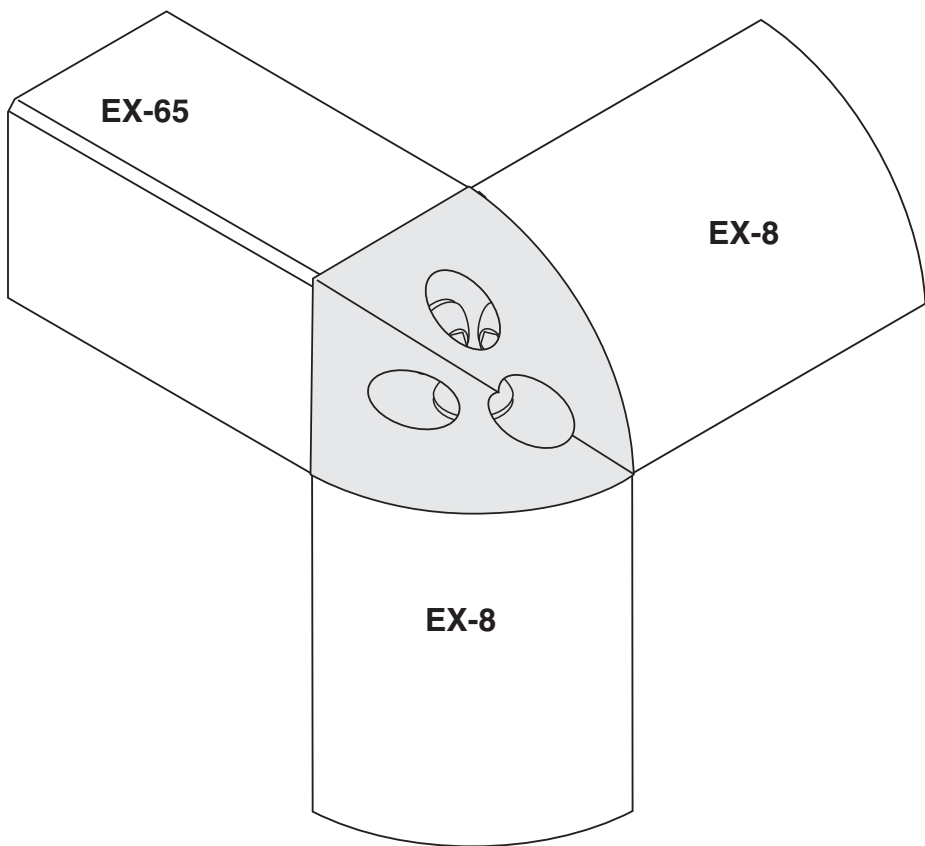

Hardware Included

Material - Aluminum  
Finish - Clear Anodize

**EB-54**

**5/16" SLOTS**

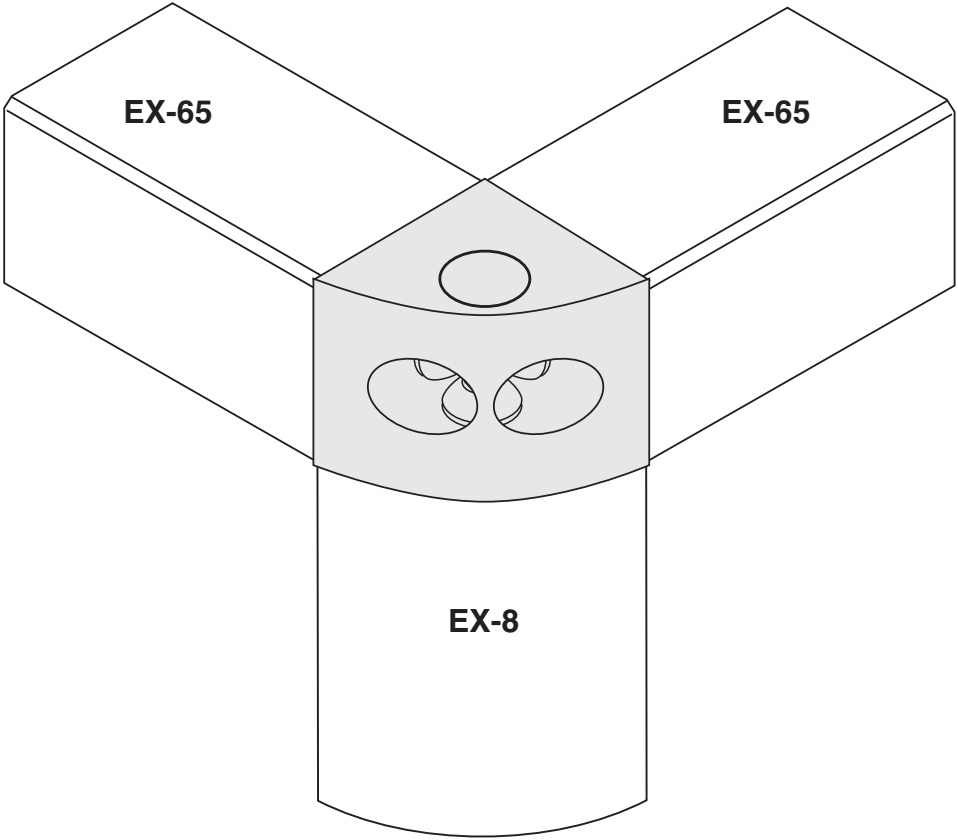

Hardware Included

Material - Aluminum  
Finish - Clear Anodize

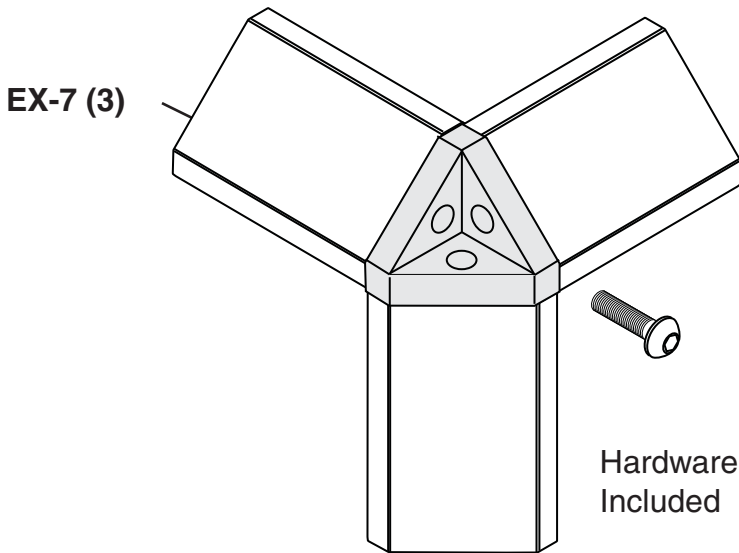
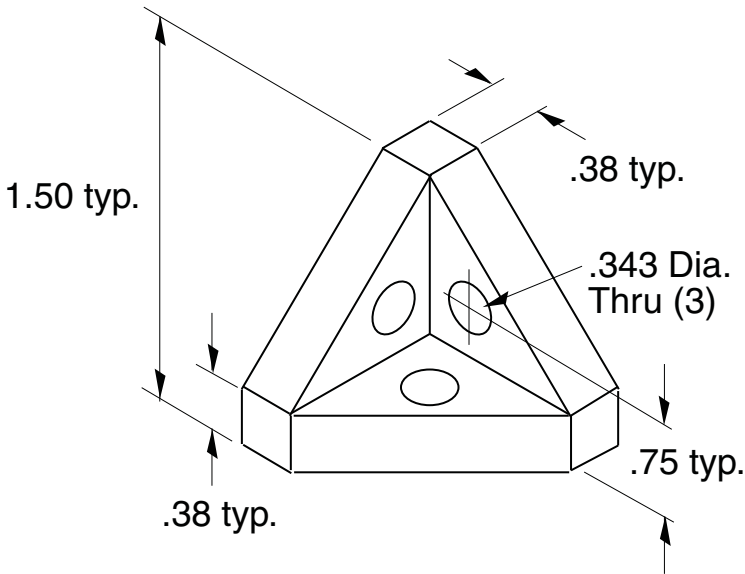

Material - Aluminum  
Finish - Clear Anodize

**EB-51**

5/16" SLOTS

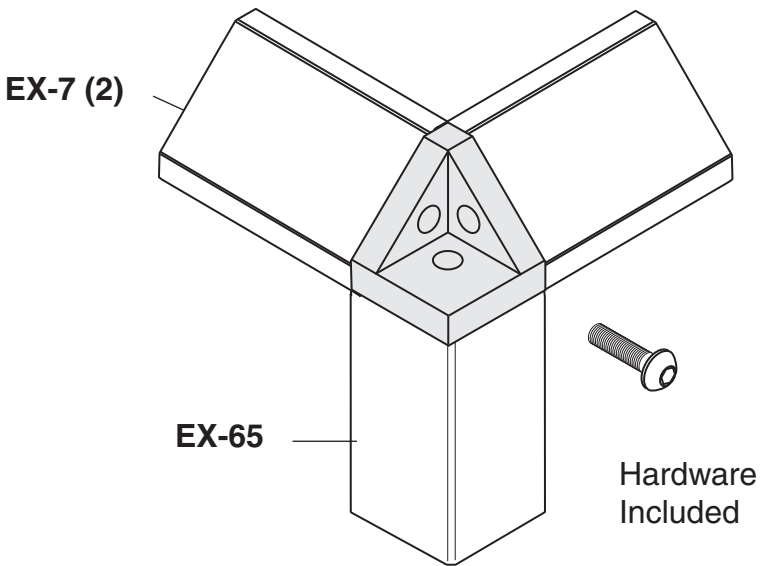
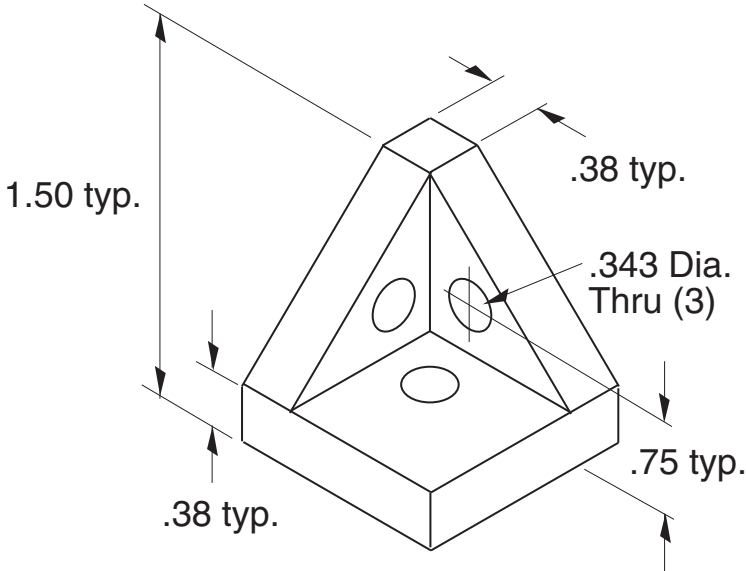

Material - Aluminum  
Finish - Clear Anodize

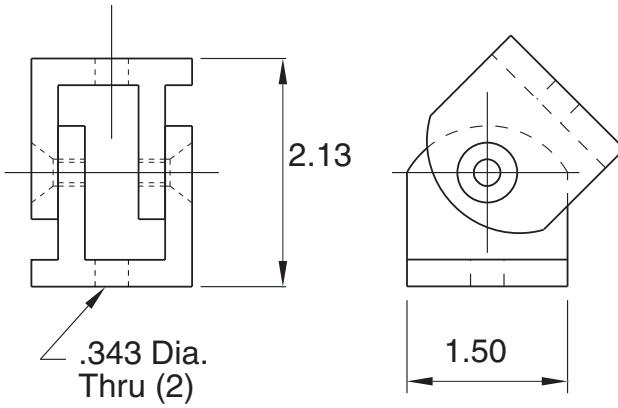

**5/16" SLOTS**

Requires  
(2) EF-11-.63 SHCS  
(1) EF-2 T-nut

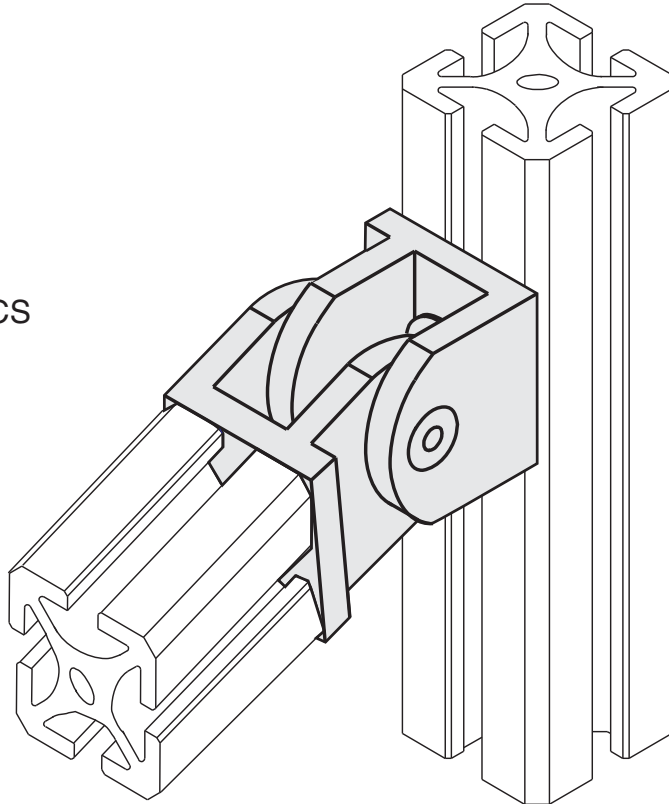

**Material - Aluminum**  
**Finish - Grey Powder Coat**

# Pivoting Hinge



## EB-13P

5/16" SLOTS

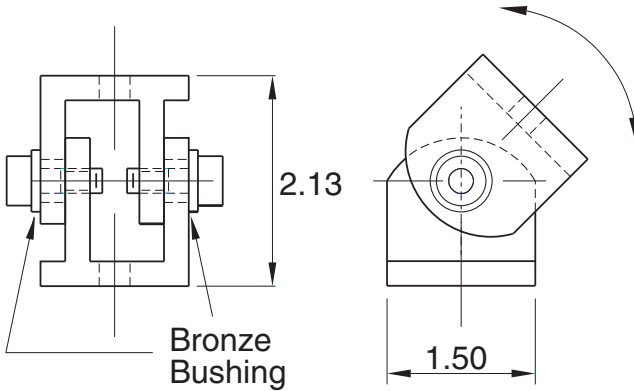

- Requires  
(2) EF-11-.63 SHCS  
(1) EF-2 T-nut

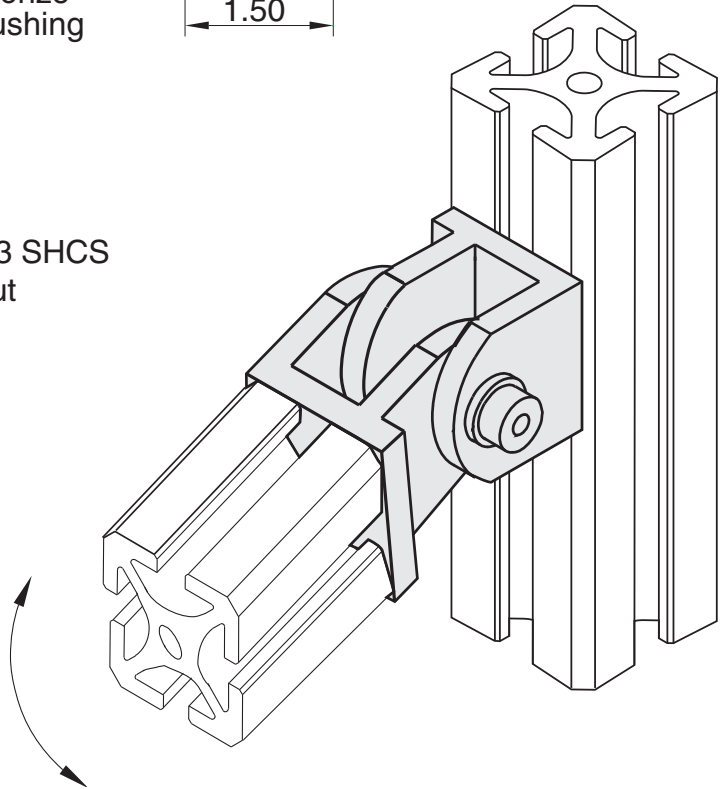

Material - Aluminum  
Finish - Grey Powder Coat

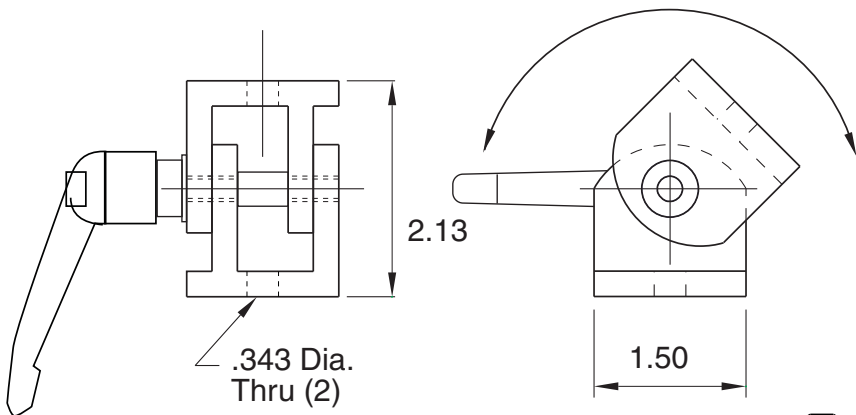

**5/16" SLOTS**

- Requires  
 (2) EF-11-.63 SHCS  
 (1) EF-2 T-nut

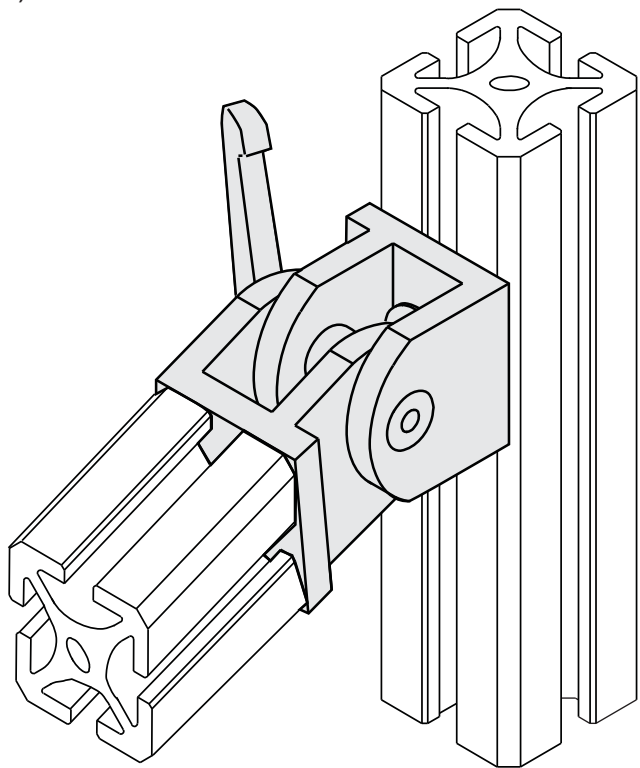

**Material - Aluminum**  
**Finish - Grey Powder Coat**



**EB-46**

5/16" SLOTS

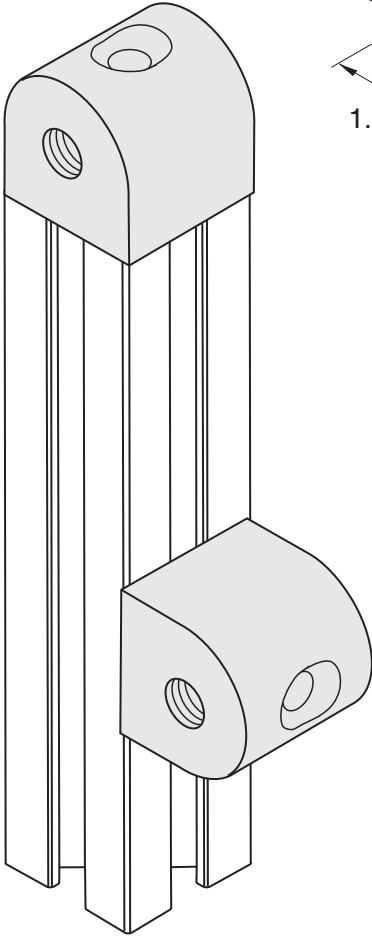
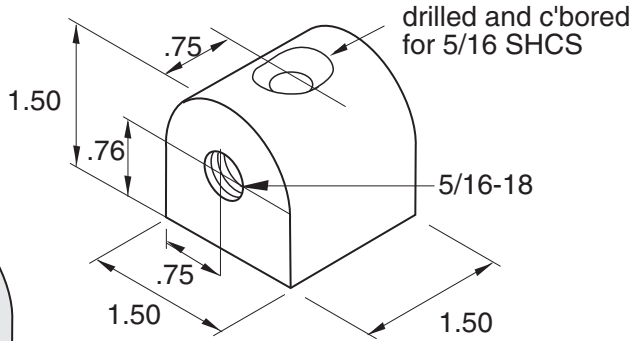

Assembly  
(2) EB-48  
(1) EB-46

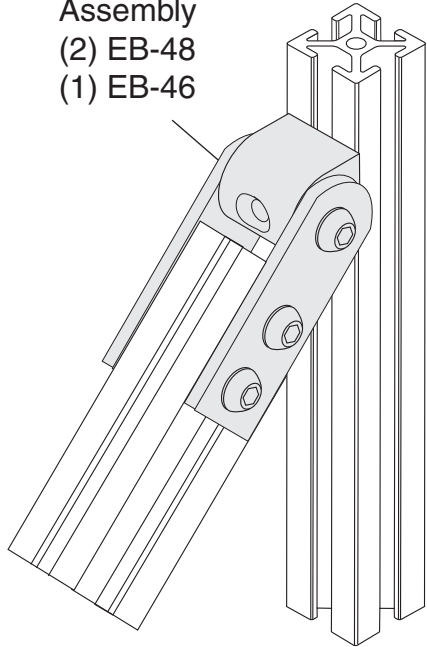

Requires  
(1) EF-11-1.25 SHCS  
(1) EF-2 T-nut

Material - Aluminum  
Finish - Clear Anodize

**EB-47**

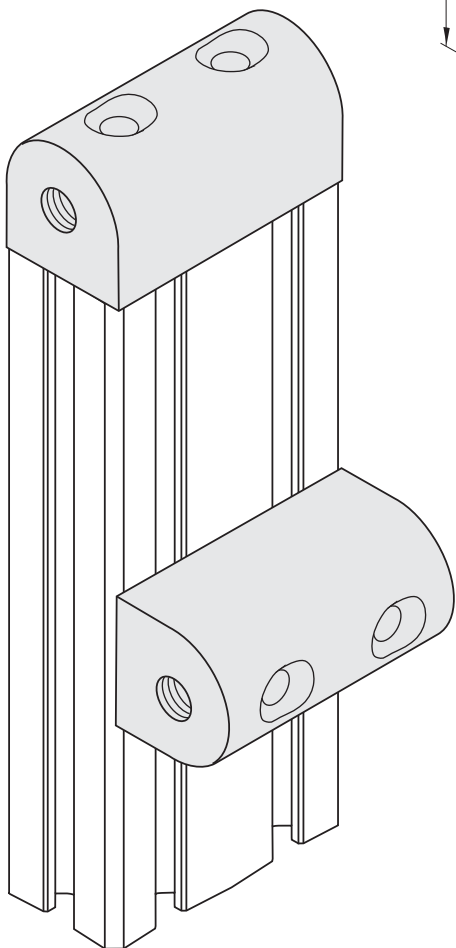
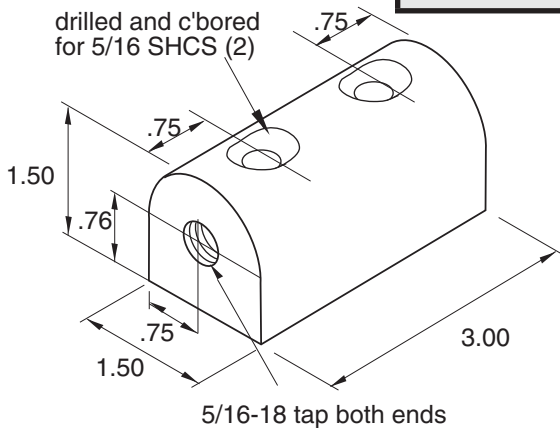

Assembly  
(2) EB-48  
(1) EB-47

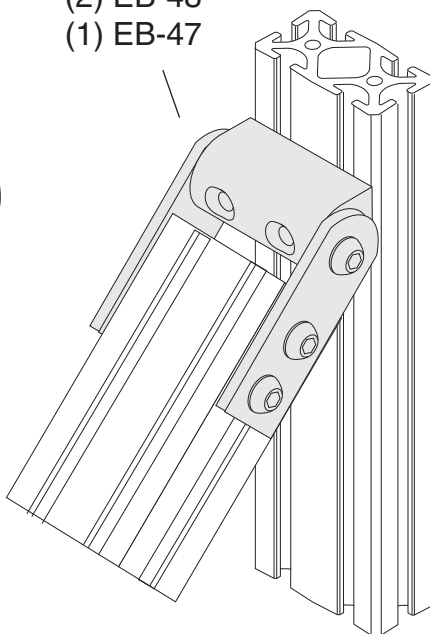

**5/16" SLOTS**

**Requires**  
(2) EF-11-1.25 SHCS  
(2) EF-2 T-nut

**Material - Aluminum**  
**Finish - Clear Anodize**

# Adjustable Arm Post



**EB-48**

use with EB-46 & EB-47

5/16" SLOTS

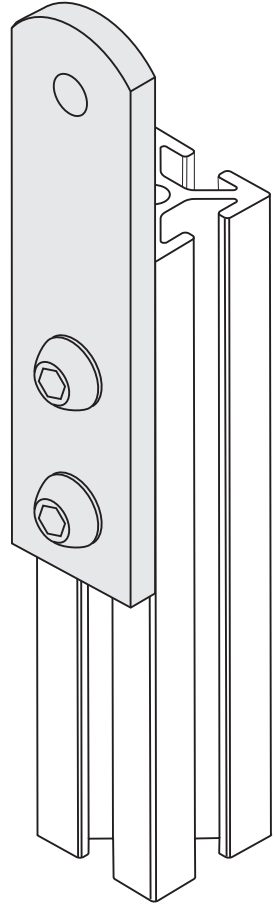
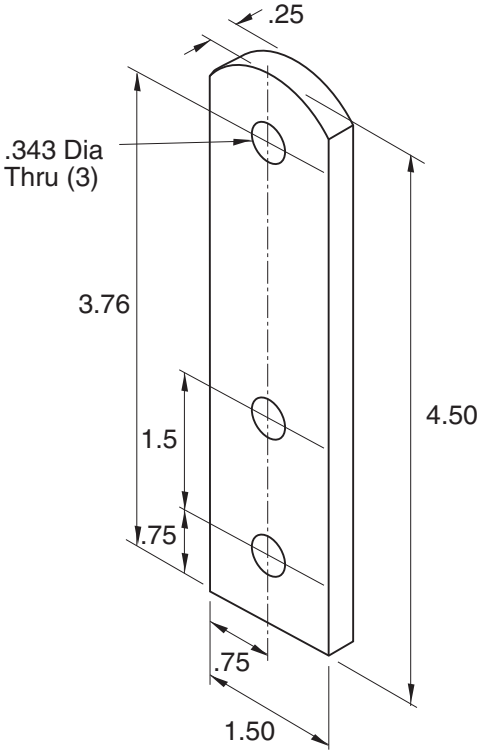

Assembly  
(2) EB-48  
(1) EB-46

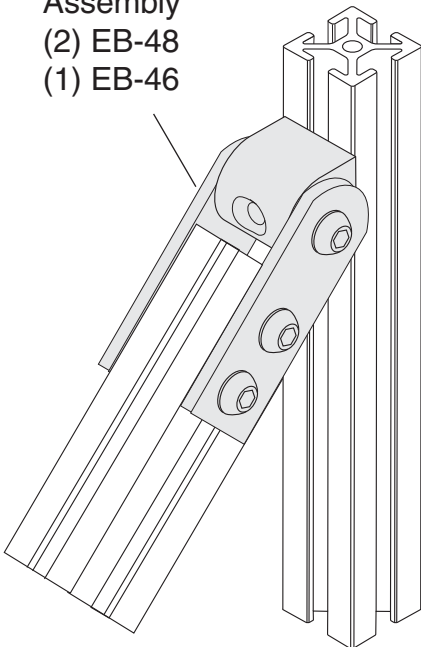

Requires  
(3) EF-12-.63 BHCS  
(2) EF-2 T-nut

Material - Aluminum  
Finish - Clear Anodize

Use with EB-46, EB-47

**EB-66**

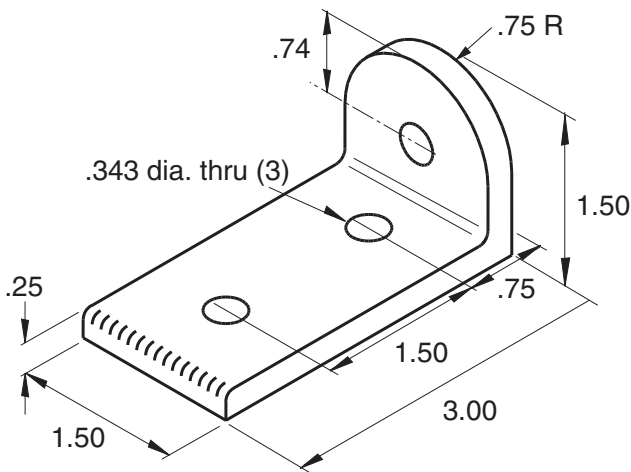

**5/16" SLOTS**

**Recomended Hardware**

(3) EF-12-.63 SHCS

(2) EF-2 T-nut

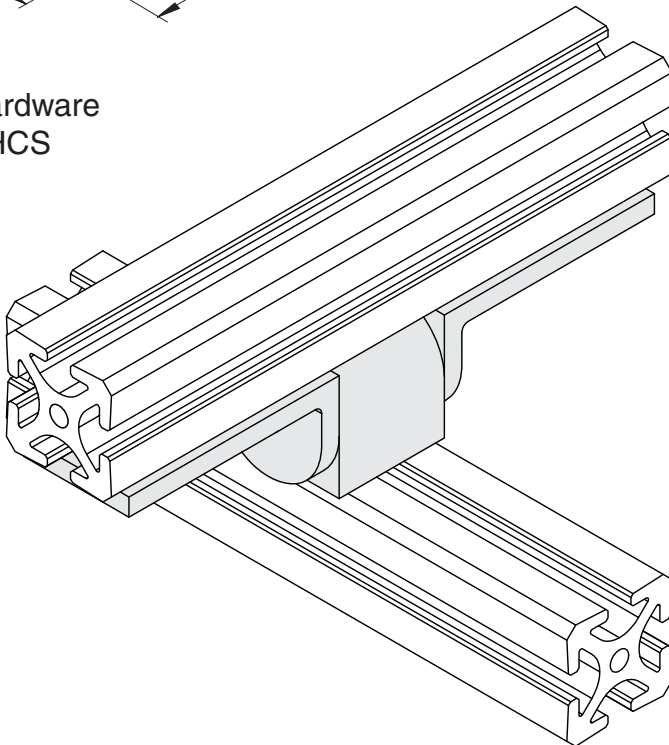

**Material - Aluminum**  
**Finish - Clear Anodize**

# Pivoting Post Arm with Bushing



**EB-65**

Use with EB-68, EB-69

For Shoulder Bolt  
order (1) EF-46

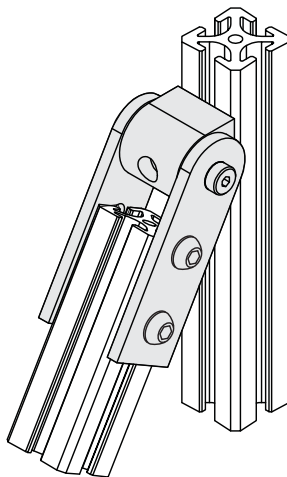
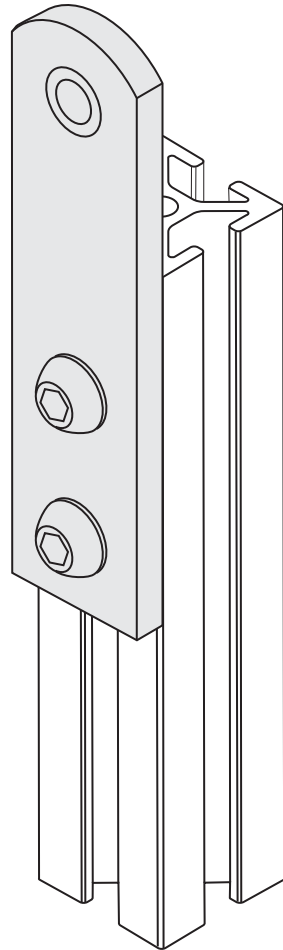
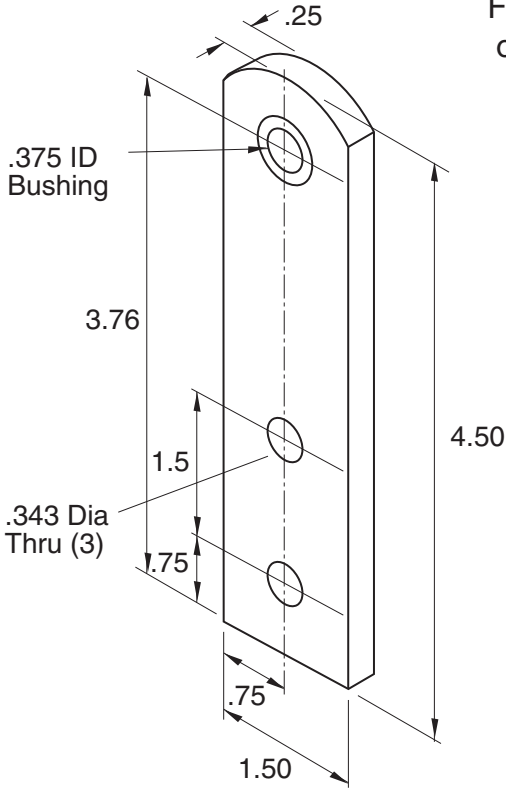

Recommended Hardware  
(2) EF-12-.63 BHCS  
(2) EF-2 T-nut  
(1) EF-46

Material - Aluminum  
Finish - Clear Anodize

5/16" SLOTS

Use with EB-68, EB-69

**EB-67**

For Shoulder  
Bolt order (1) EF-46

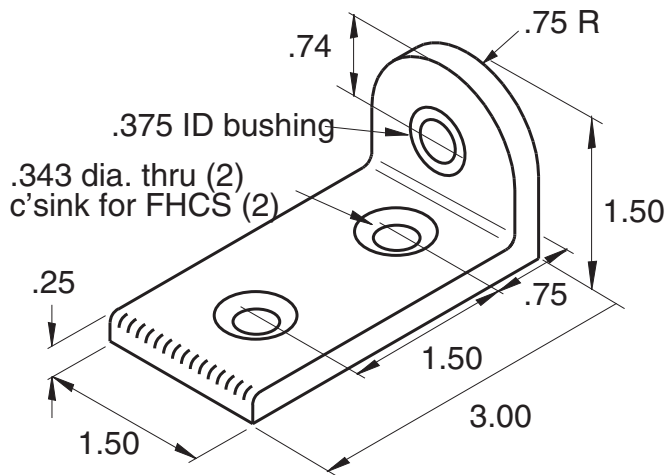

5/16" SLOTS

**Recommended Hardware**

- (2) 5/16-18 x 5/8 FHCS
- (2) EF-2 T-nut
- (1) EF-46

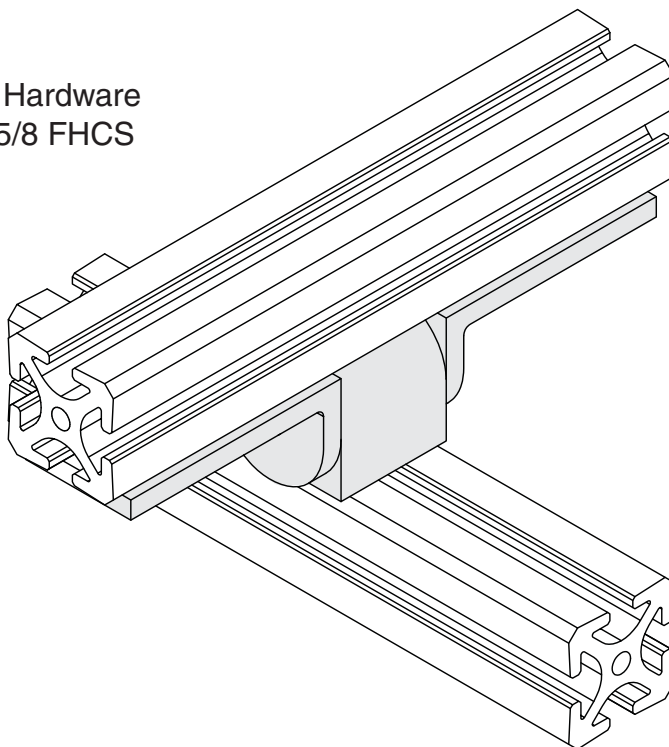

Material - Aluminum  
Finish - Clear Anodize

# Pivoting Corner Post



**EB-68**

Use with (2) EB-65 or (2) EB-67

5/16" SLOTS

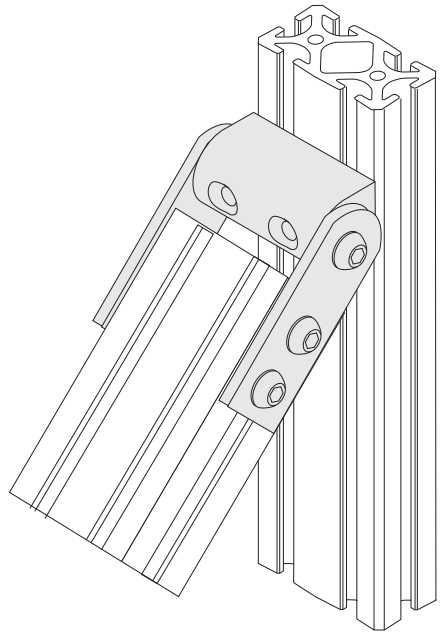
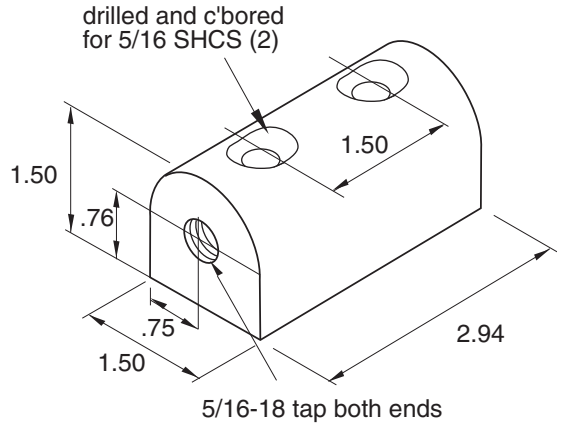
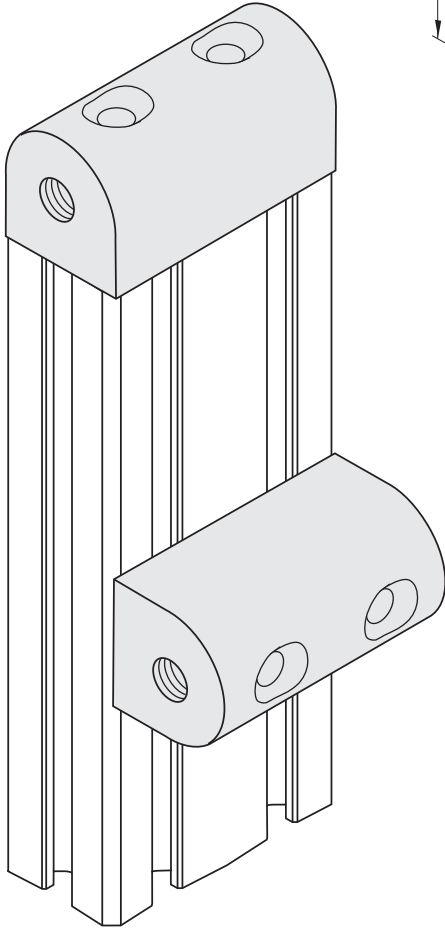

Recomended Hardware  
(2) EF-11-1.25 SHCS  
(2) EF-2 T-nut

Material - Aluminum  
Finish - Clear Anodize

Use with (2) EB-65 or (2) EB-67

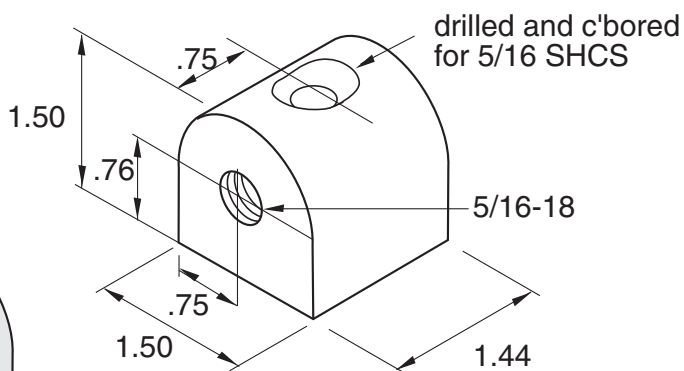
**EB-69****5/16" SLOTS**

Recomended Hardware  
(1) EF-11-1.25 SHCS  
(1) EF-2 T-nut

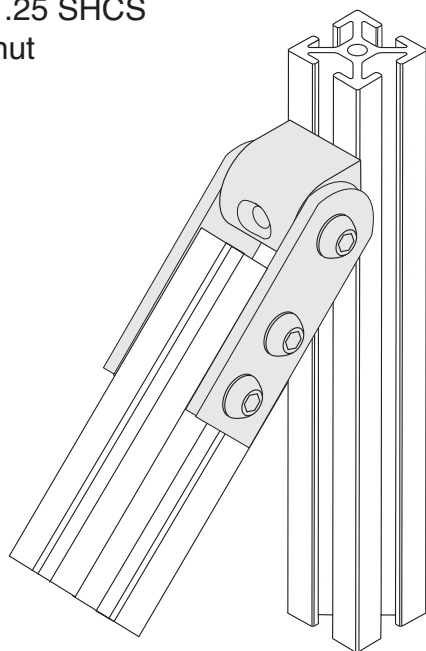
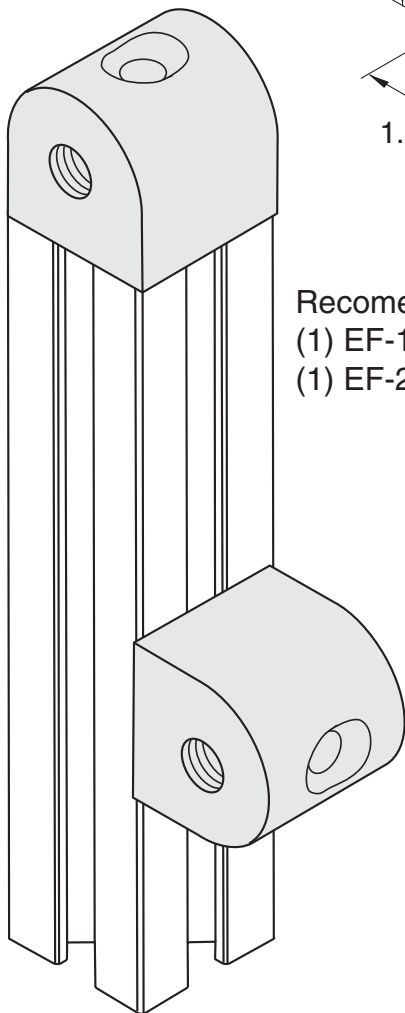

Material - Aluminum  
Finish - Clear Anodize



# Joining Plate



**EB-33**  
**EB-33-S**

1 hole is slotted

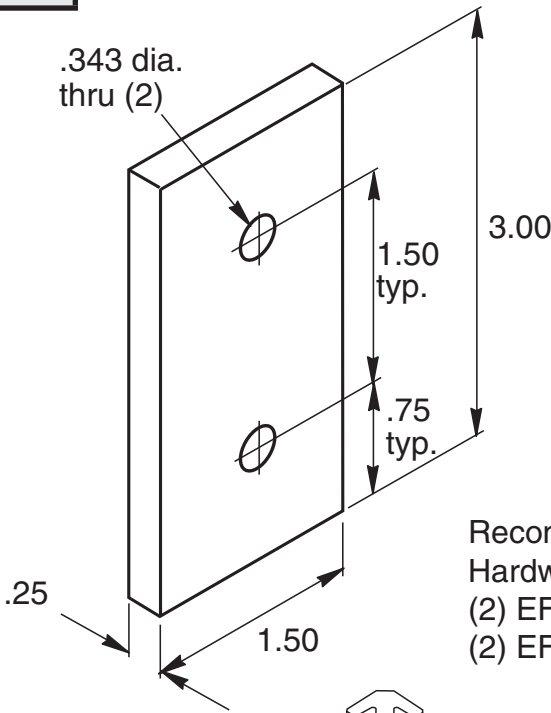

Recommended Hardware  
(2) EF-12-.63 BHCS  
(2) EF-2 T-nut

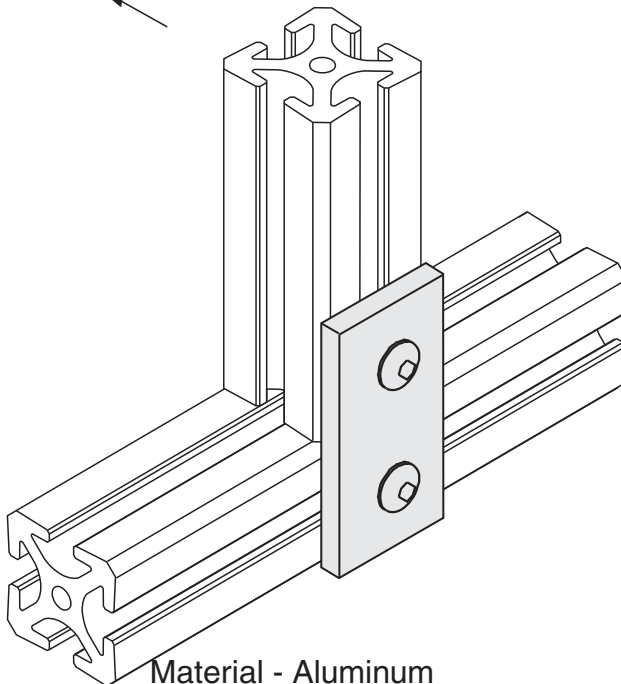

Material - Aluminum  
Finish - Clear Anodize

5/16" SLOTS

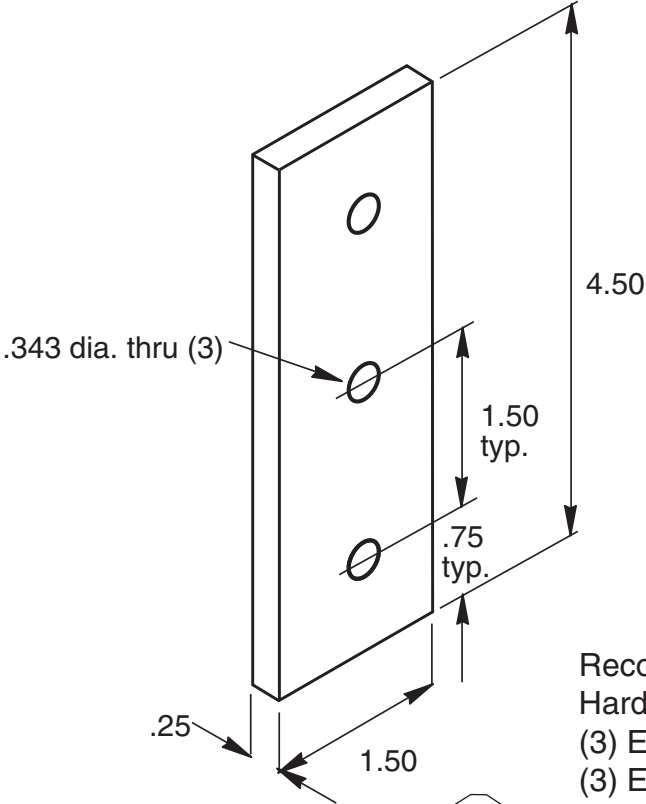

Recommended  
Hardware  
(3) EF-12-.63 BHCS  
(3) EF-2 T-nut

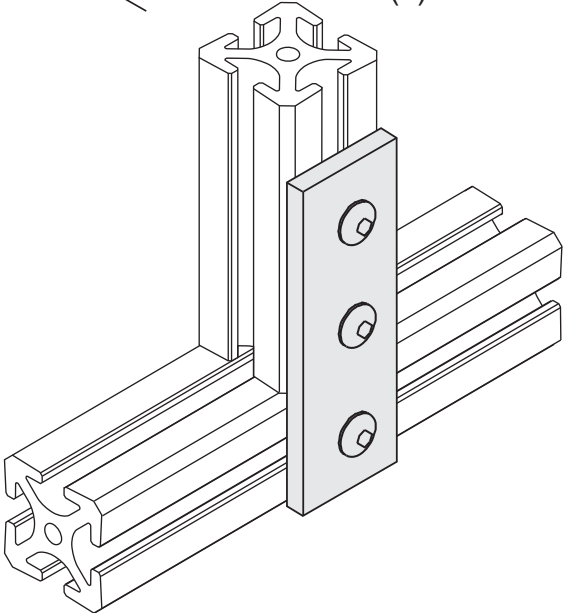

Material - Aluminum  
Finish - Clear Anodize

**EB-28**

5/16" SLOTS

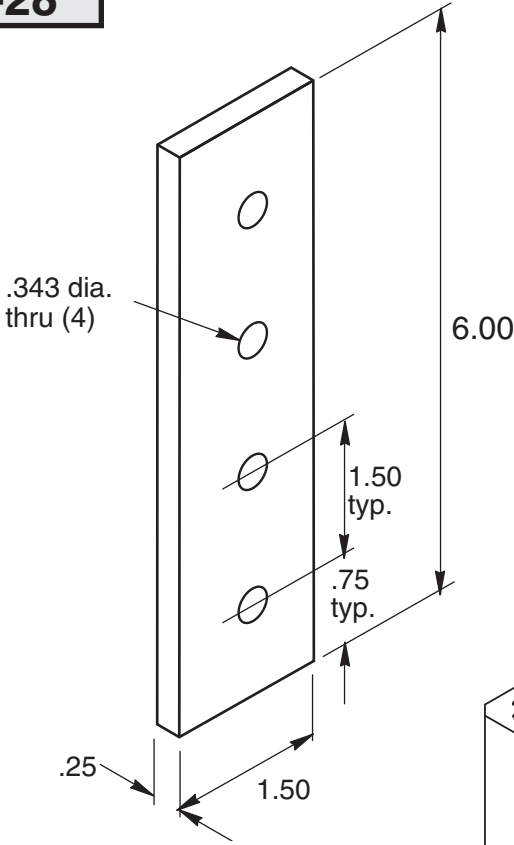

Recommended Hardware  
(4) EF-12-.63 BHCS  
(4) EF-2 T-nut

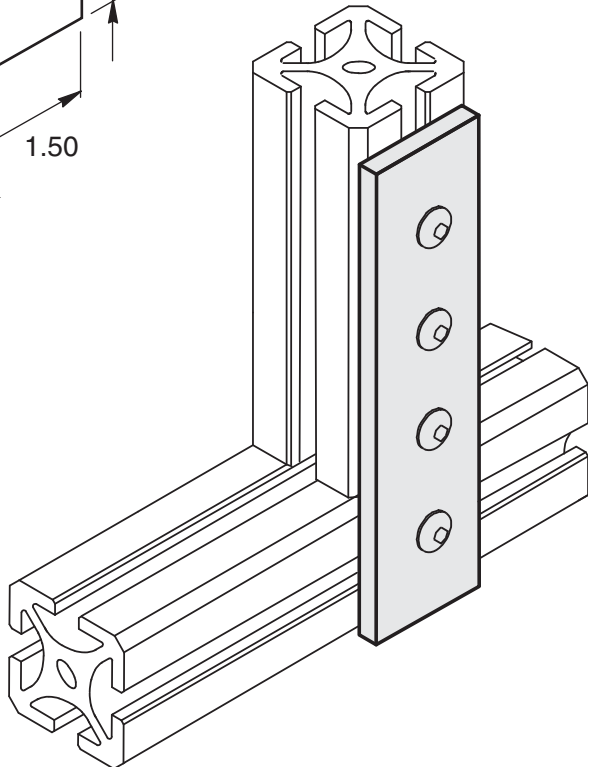

Material - Aluminum  
Finish - Clear Anodize

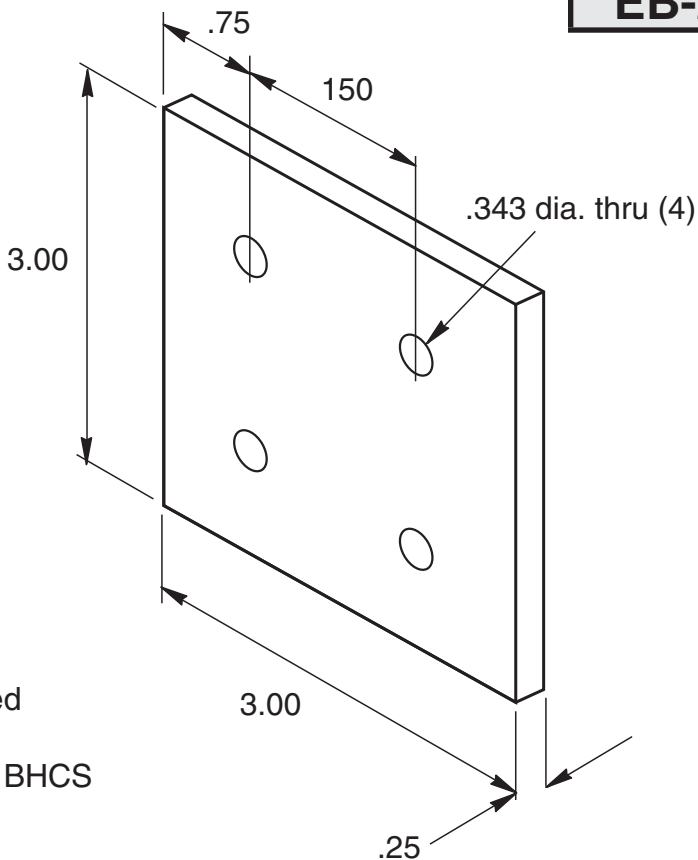

Recommended  
Hardware  
(4) EF-12-.63 BHCS  
(4) EF-2 T-nut

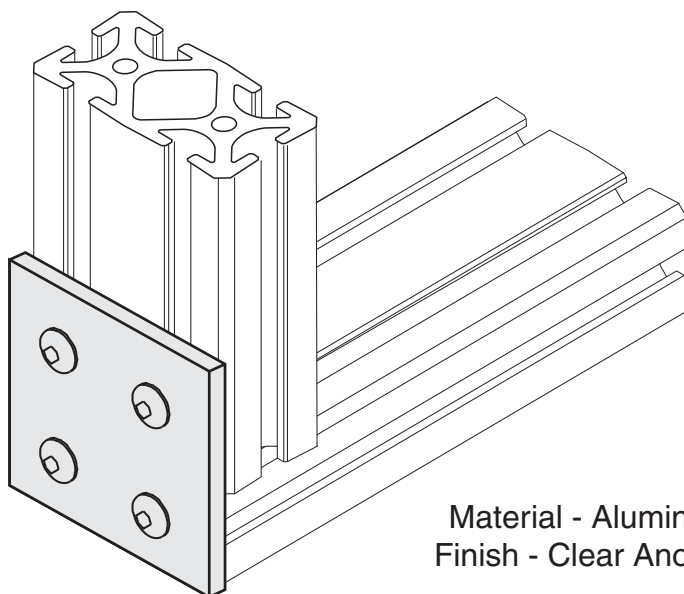

Material - Aluminum  
Finish - Clear Anodize

**5/16" SLOTS**

**EB-32**

5/16" SLOTS

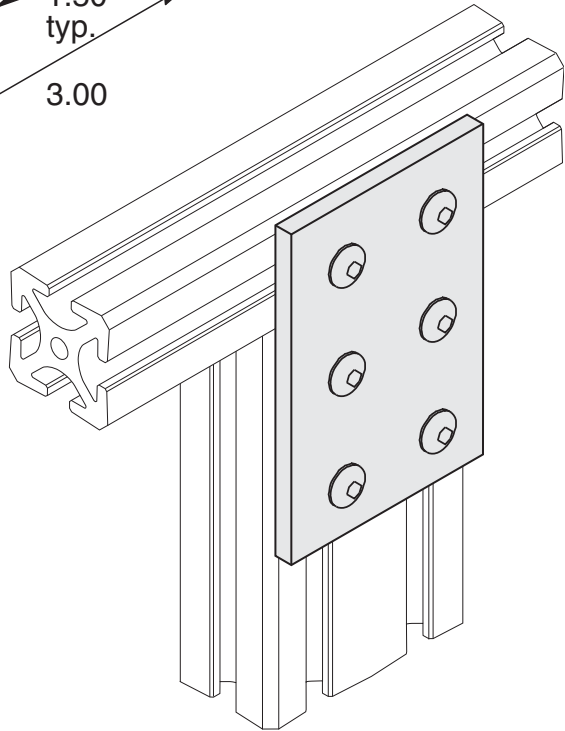
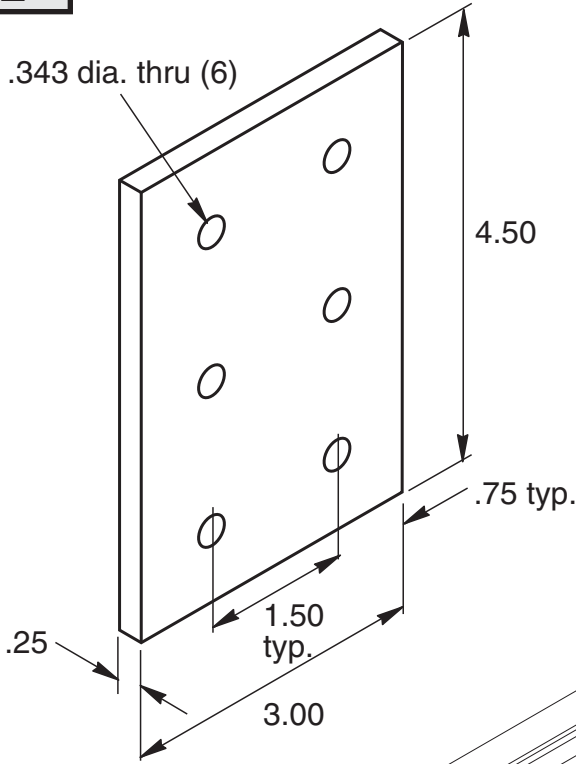

Recommended  
Hardware  
(6) EF-12-.63 BHCS  
(6) EF-2 T-nut

Material - Aluminum  
Finish - Clear Anodize

**EB-26**

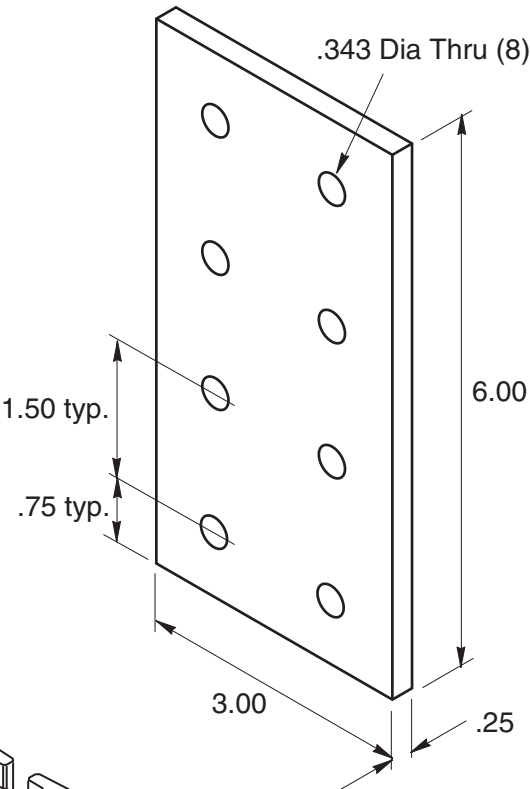

**5/16" SLOTS**

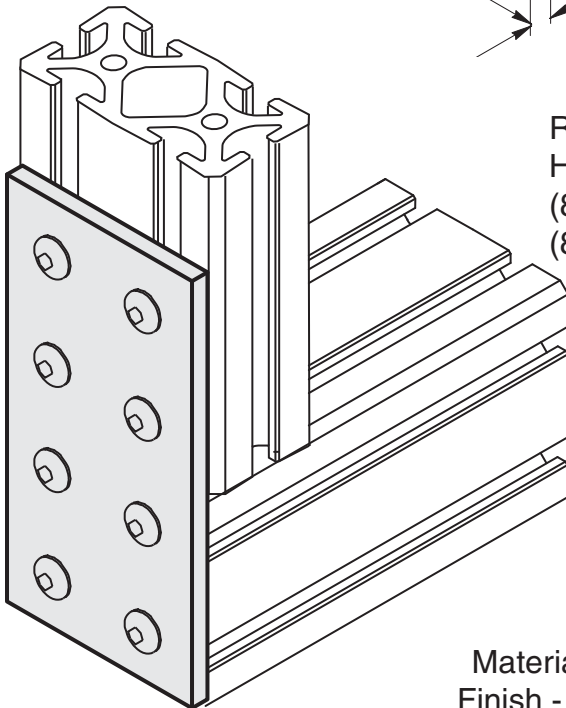

**Recommended  
Hardware**  
(8) EF-12- .63 BHCS  
(8) EF-2 T-nut

**Material - Aluminum  
Finish - Clear Anodize**

# Joining Plate



**EB-83**

**5/16" SLOTS**

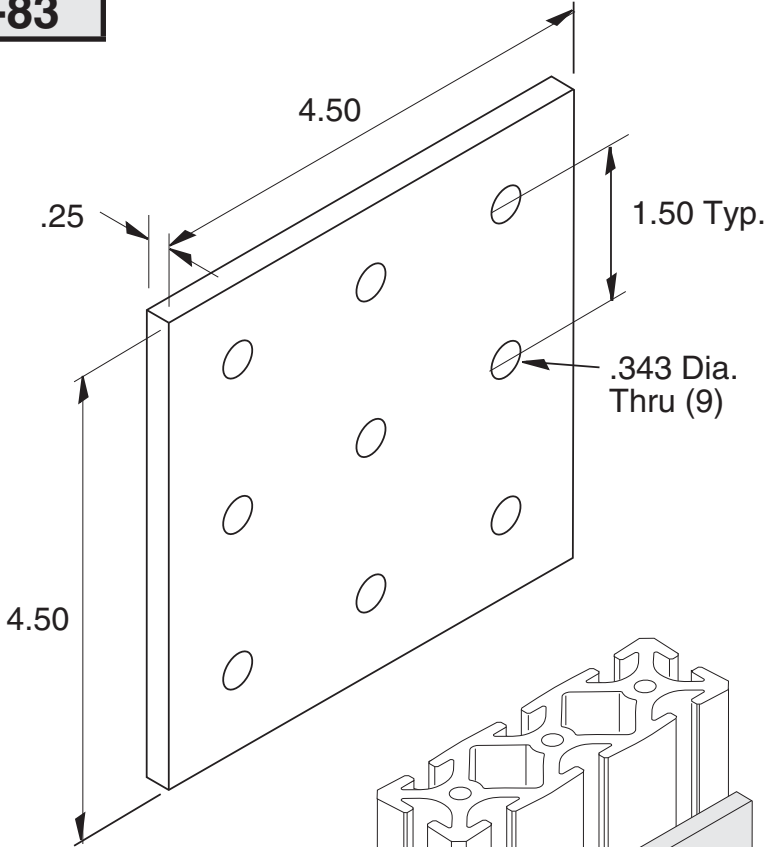

Recommended Hardware  
(9) EF-12-.63 BHCS  
(9) EF-2 T-nut

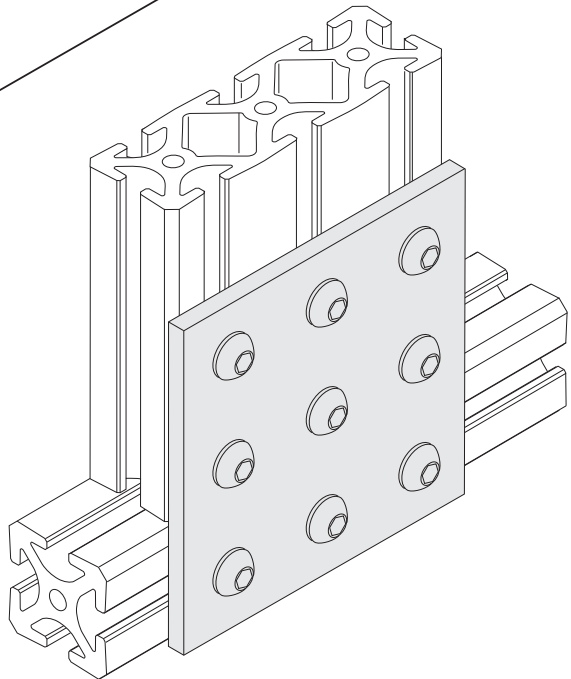

Material - Aluminum  
Finish - Clear Anodize

**EB-84**

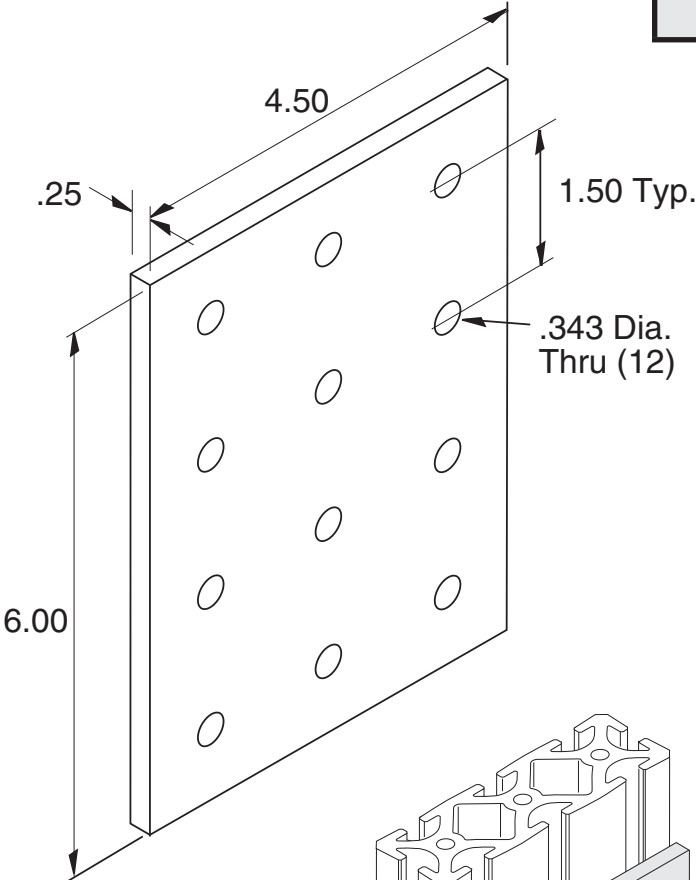

**5/16" SLOTS**

Recommended  
Hardware  
(12) EF-12- .63 BHCS  
(12) EF-2 T-nut

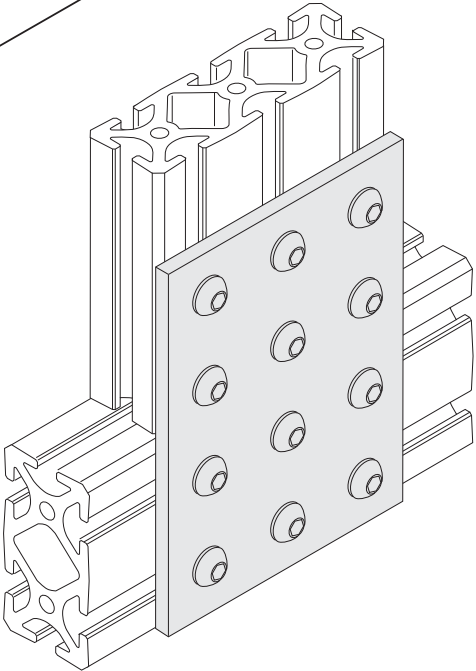

**Material - Aluminum  
Finish - Clear Anodize**



**EB-85**

**5/16" SLOTS**

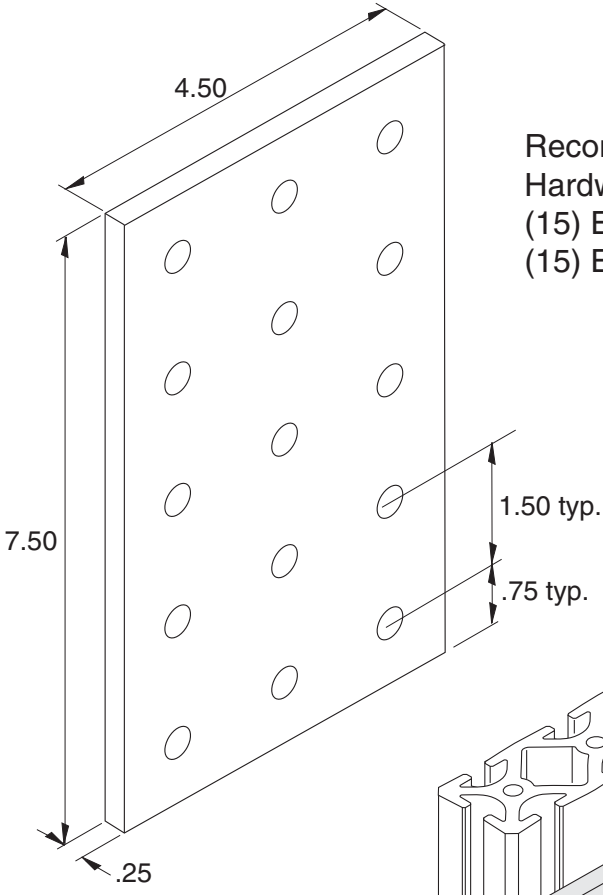

Recommended  
Hardware  
(15) EF-12-.63 BHCS  
(15) EF-2 T-nut

Material - Aluminum  
Finish - Clear Anodize

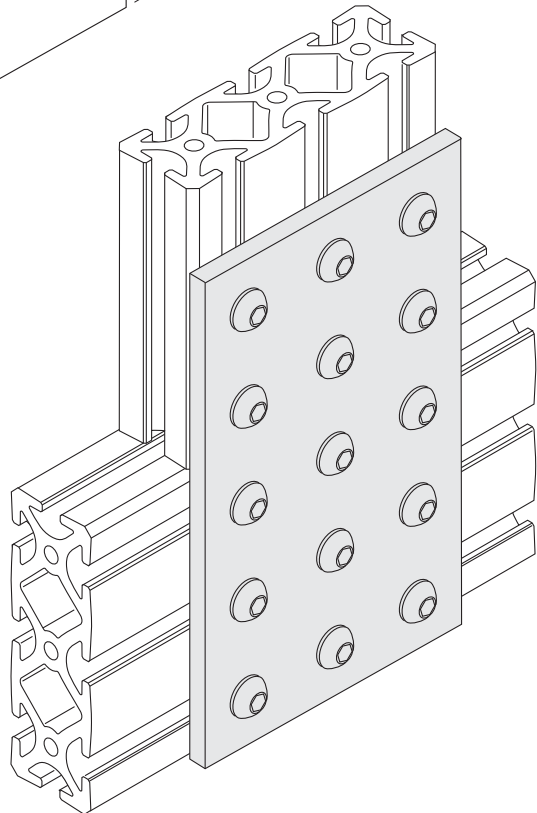

**5/16" SLOTS**

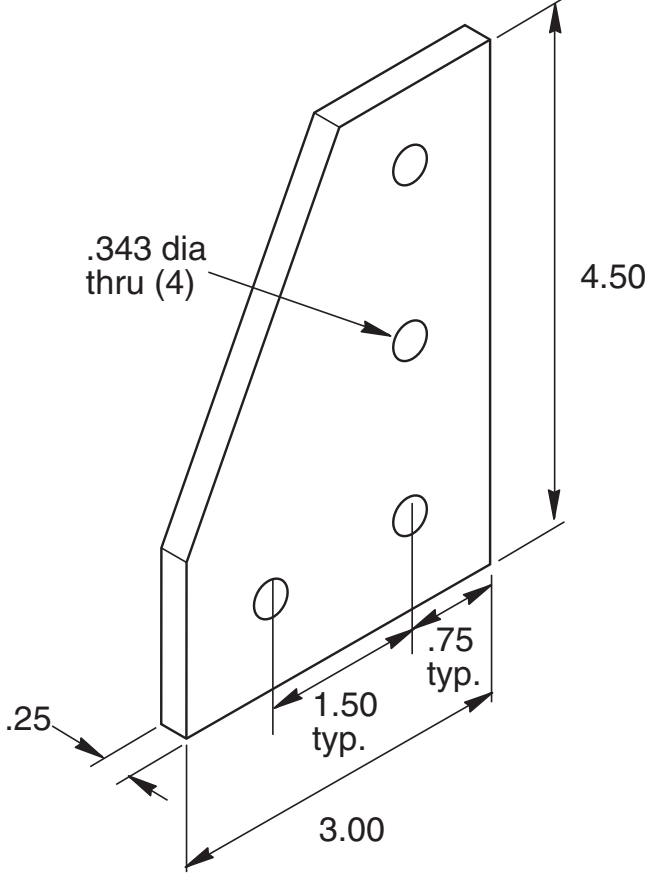

Recommended Hardware  
 (4) EF-12-.63 BHCS  
 (4) EF-2 T-nut

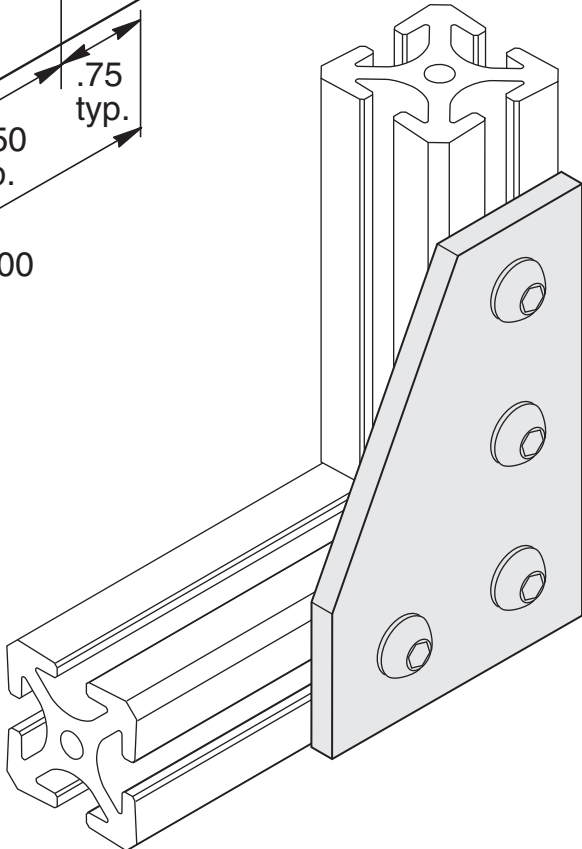

**Material - Aluminum**  
**Finish - Clear Anodize**

**EB-22**

5/16" SLOTS

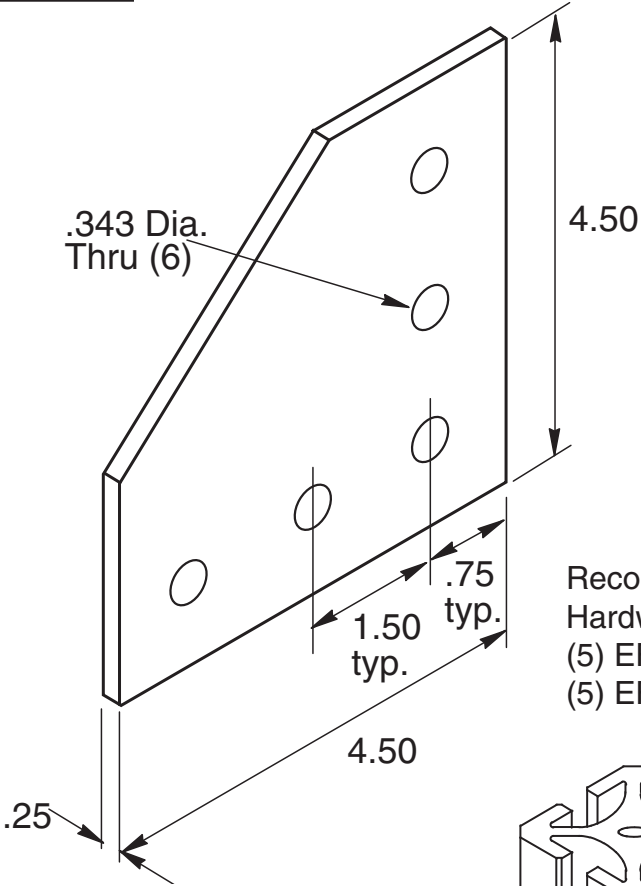

Recommended Hardware  
(5) EF-12-.63 BHCS  
(5) EF-2 T-nut

Material - Aluminum  
Finish - Clear Anodize

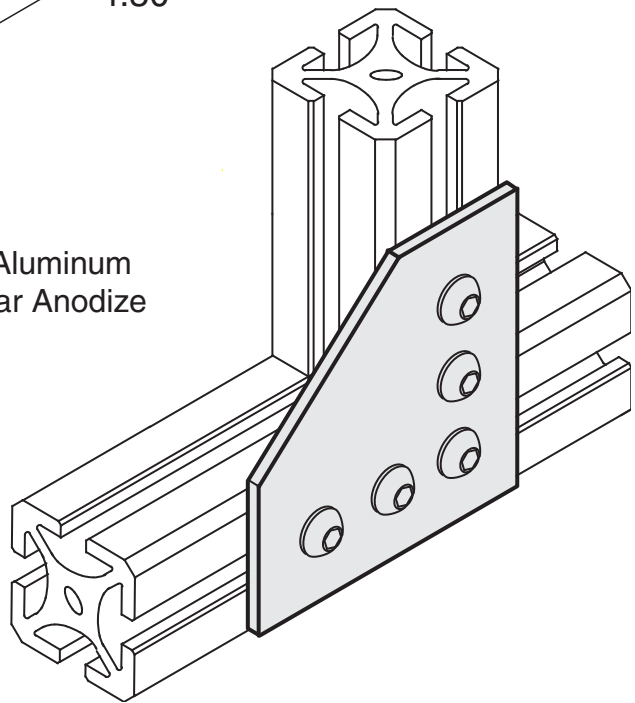

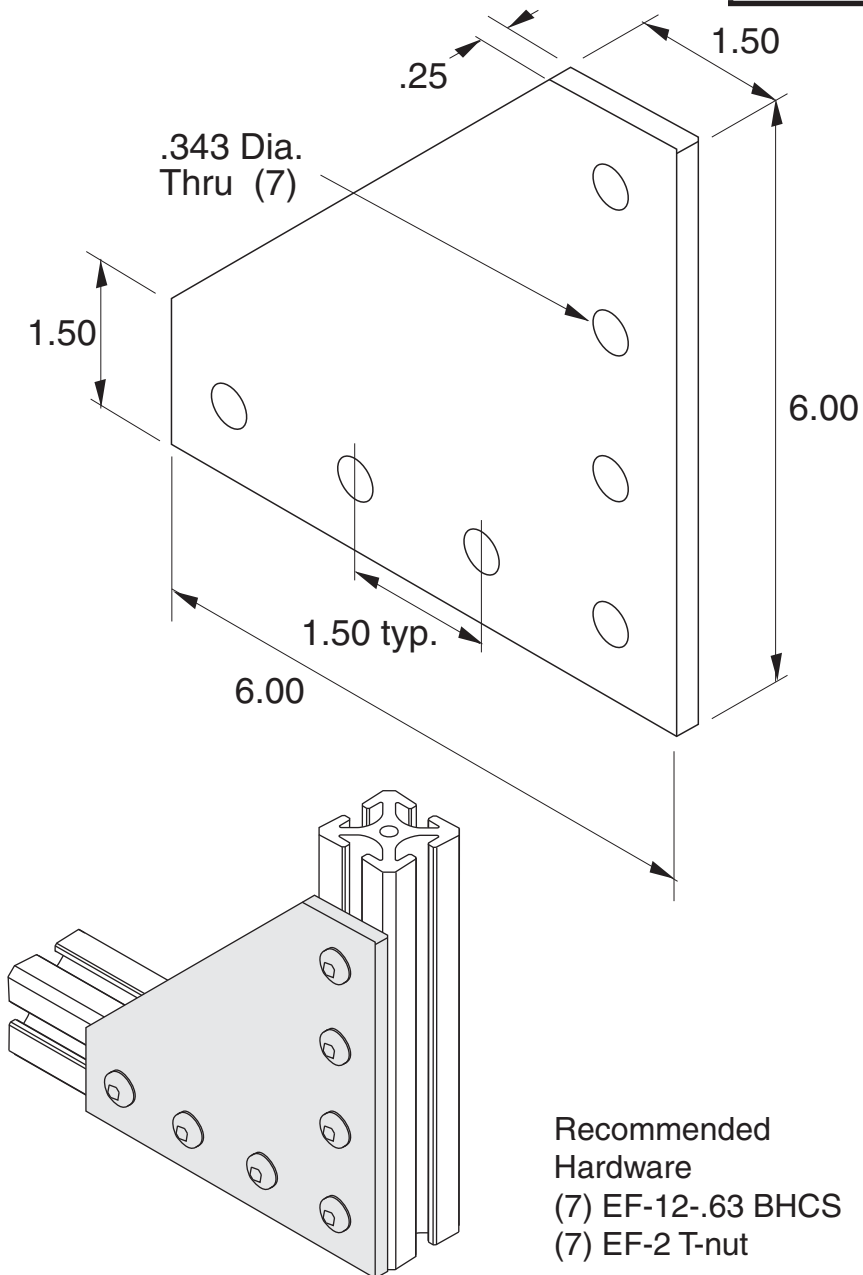

**5/16" SLOTS**

**Material - Aluminum**  
**Finish - Clear Anodize**

**EB-34**

5/16" SLOTS

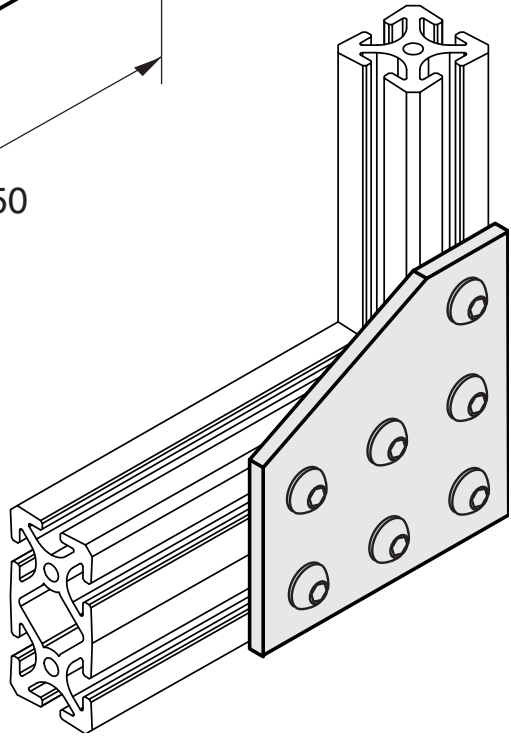
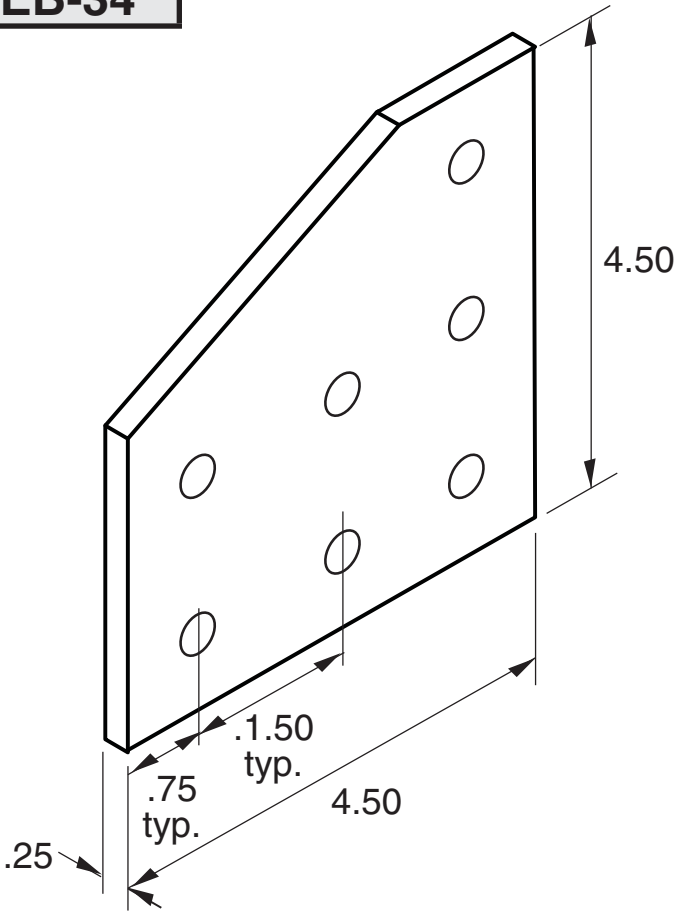

- Recommended Hardware  
(7) EF-12-.63 BHCS  
(7) EF-2 T-nut

Material - Aluminum  
Finish - Clear Anodize

**EB-27**

**5/16" SLOTS**

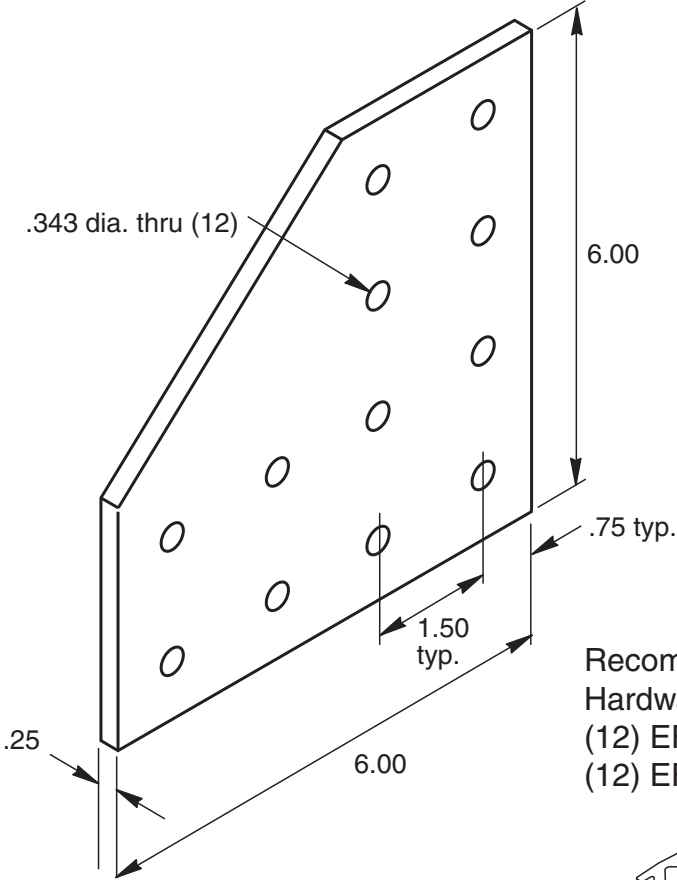

**Recommended  
Hardware**  
(12) EF-12-.63 BHCS  
(12) EF-2 T-nut

**Material - Aluminum**  
**Finish - Clear Anodize**

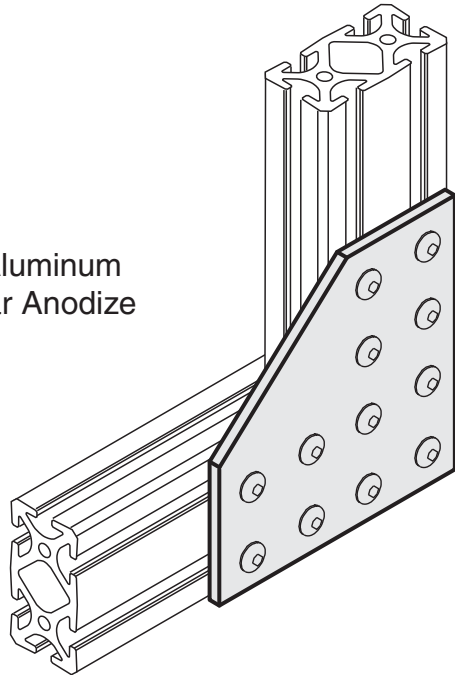

**EB-73**

5/16" SLOTS

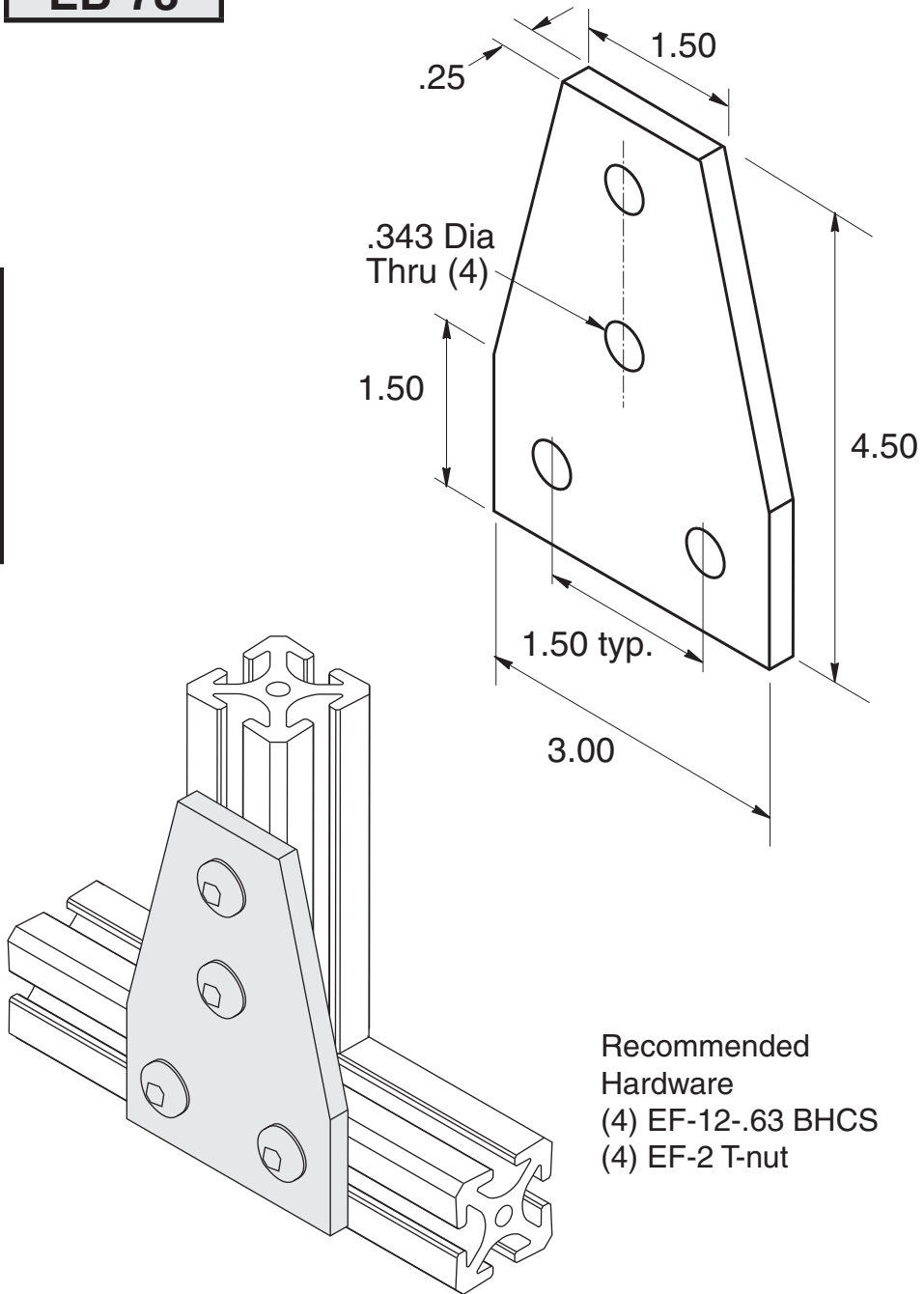

Recommended Hardware  
(4) EF-12-.63 BHCS  
(4) EF-2 T-nut

Material - Aluminum  
Finish - Clear Anodize

**EB-23**

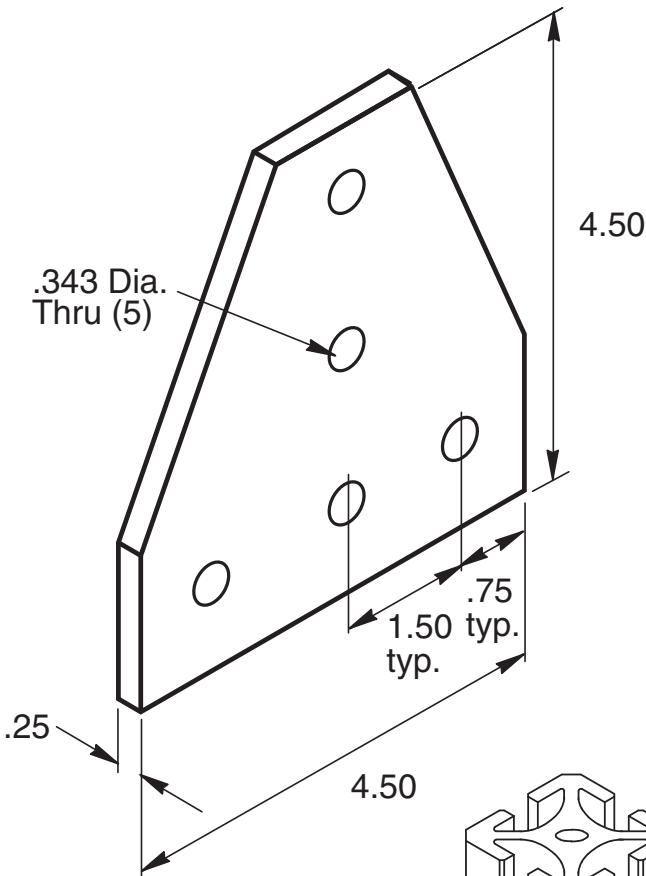

5/16" SLOTS

Recommended  
Hardware  
(5) EF-12-.63 BHCS  
(5) EF-2 T-nut

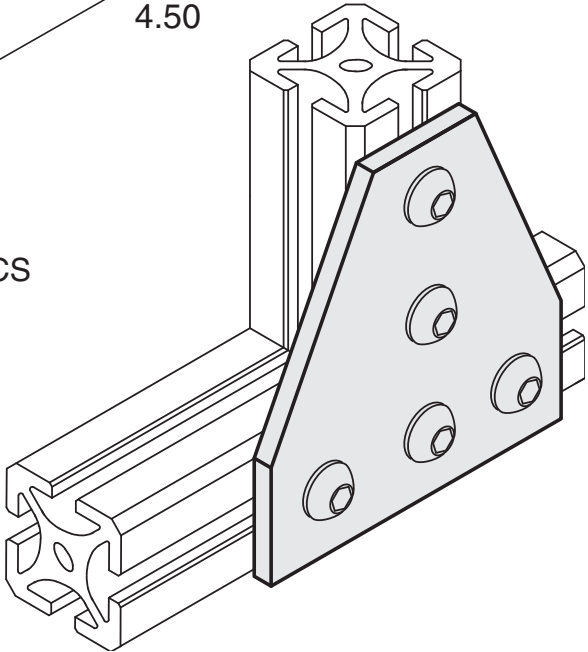

Material - Aluminum  
Finish - Clear Anodize



# Joining Plate



**EB-74**

5/16" SLOTS

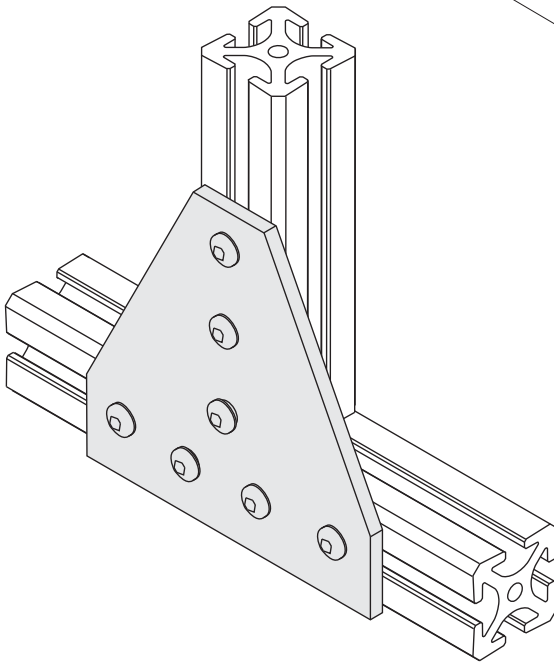
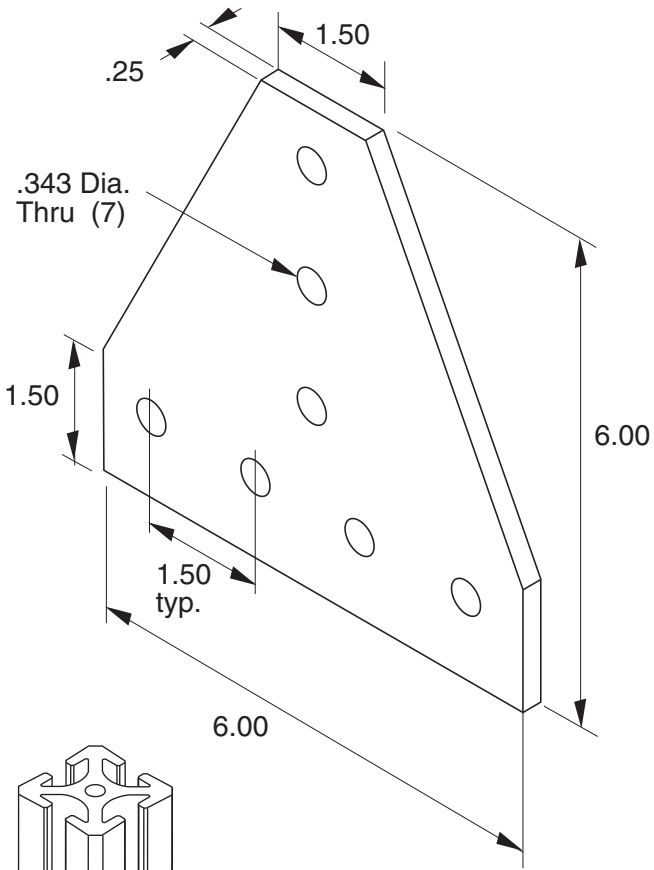

Recommended Hardware  
(7) EF-12-.63 BHCS  
(7) EF-2 T-nut

Material - Aluminum  
Finish - Clear Anodize

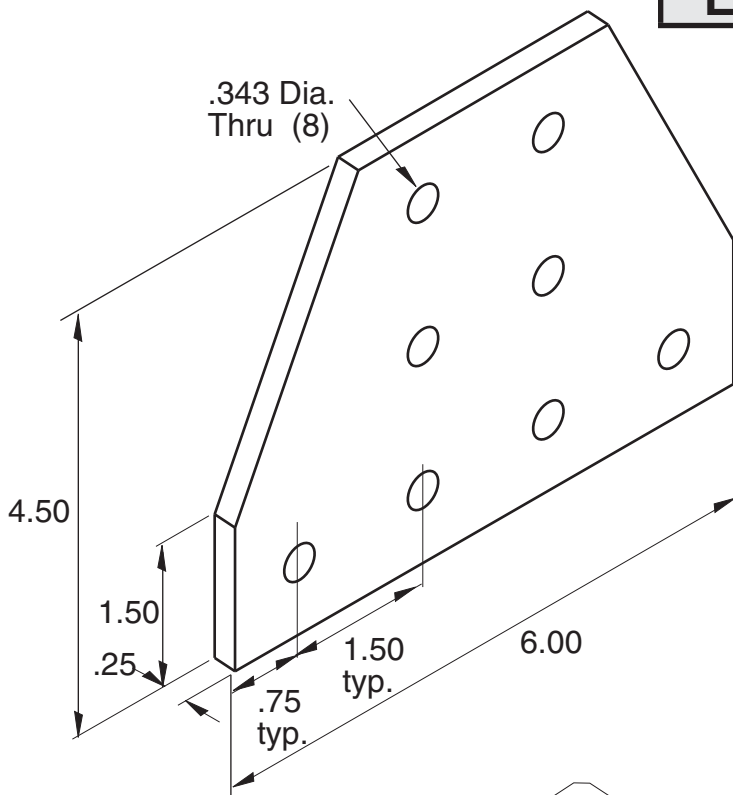

**5/16" SLOTS**

Recommended  
Hardware  
(8) EF-12-.63 BHCS  
(8) EF-2 T-nut

Material - Aluminum  
Finish - Clear Anodize

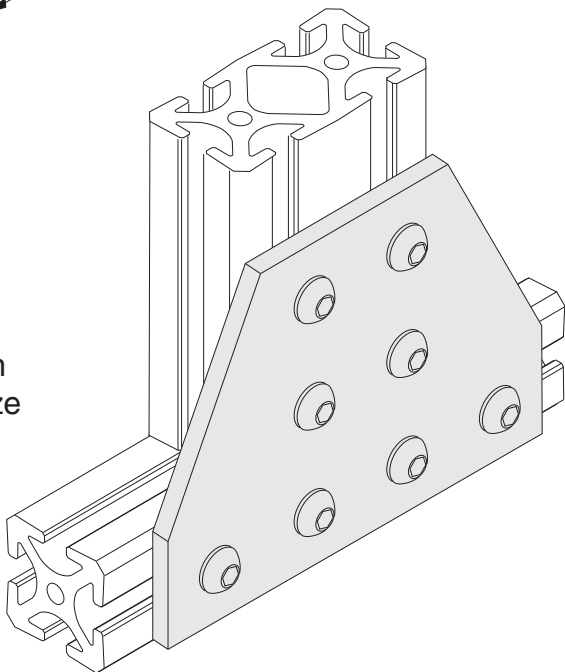

**EB-24**

5/16" SLOTS

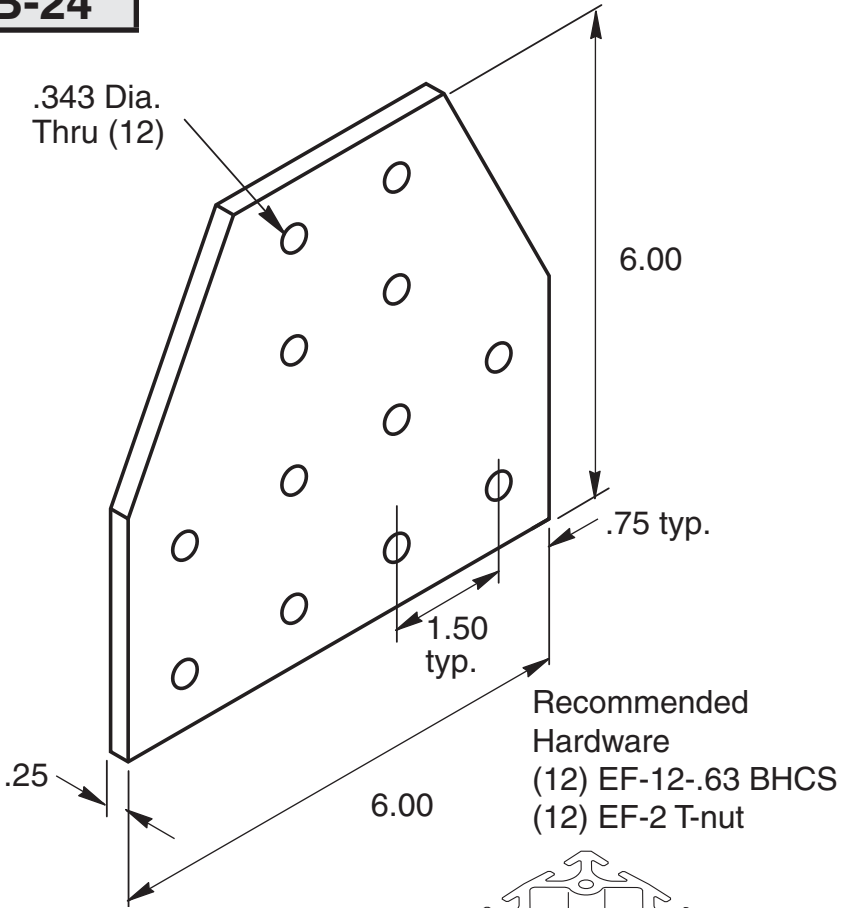

Material - Aluminum  
Finish - Clear Anodize

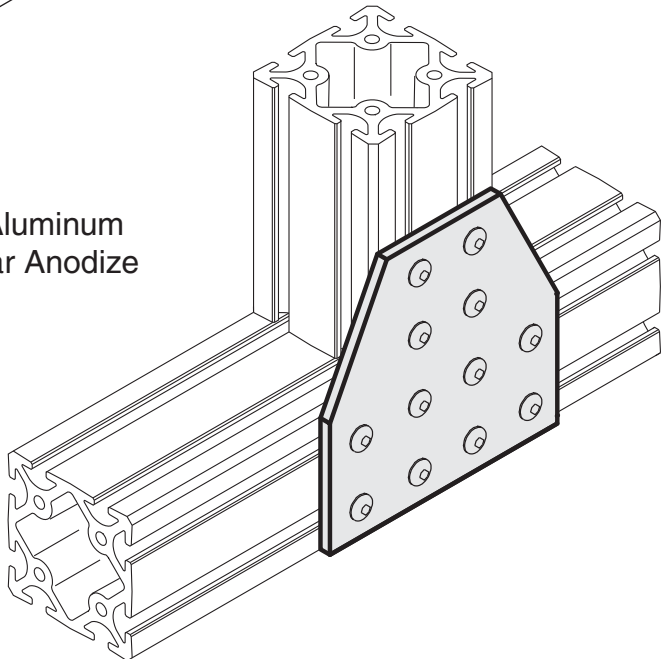

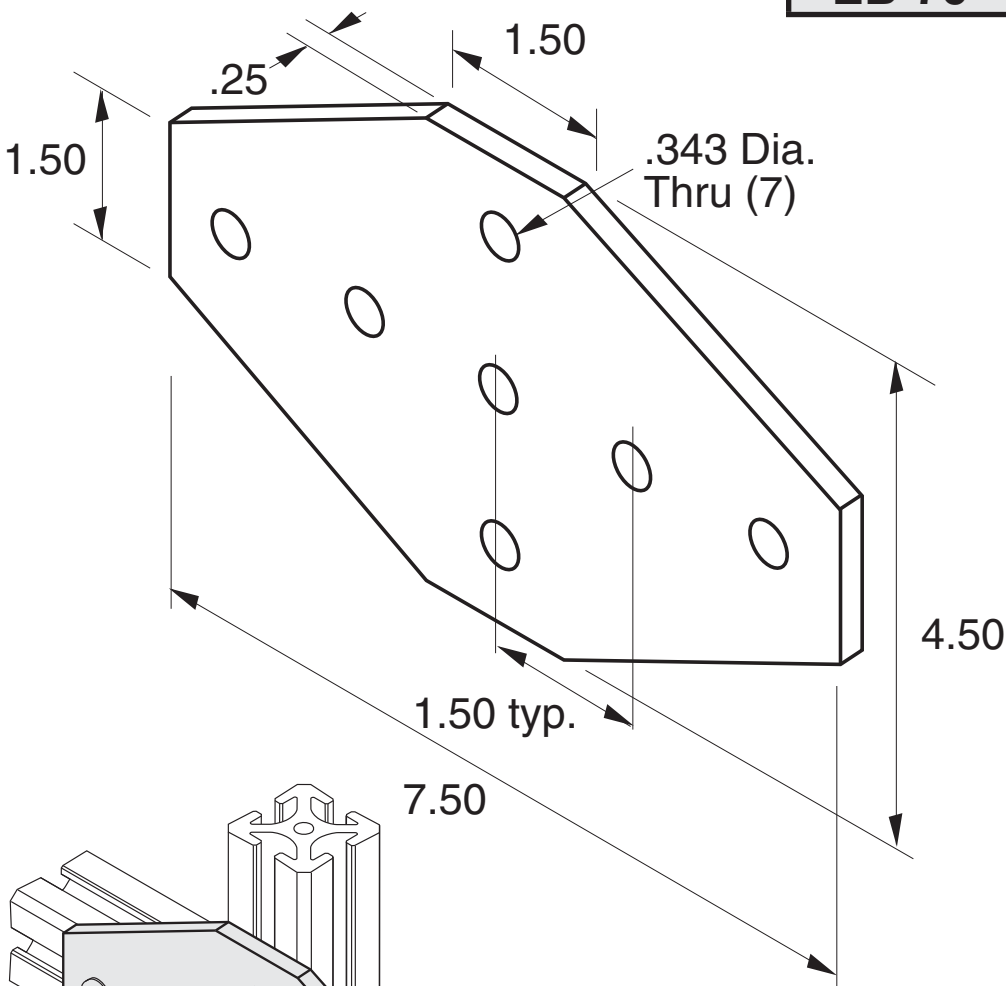

5/16" SLOTS

Recommended  
Hardware  
(7) EF-12-.63 BHCS  
(7) EF-2 T-nut

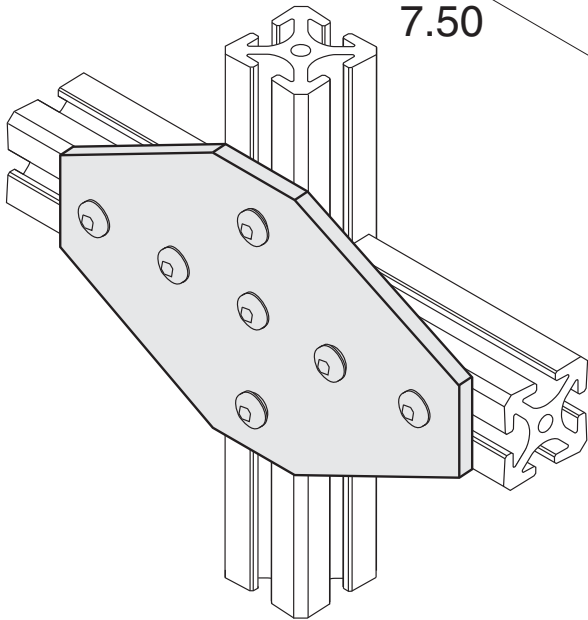

Material - Aluminum  
Finish - Clear Anodize

**EB-78**

5/16" SLOTS

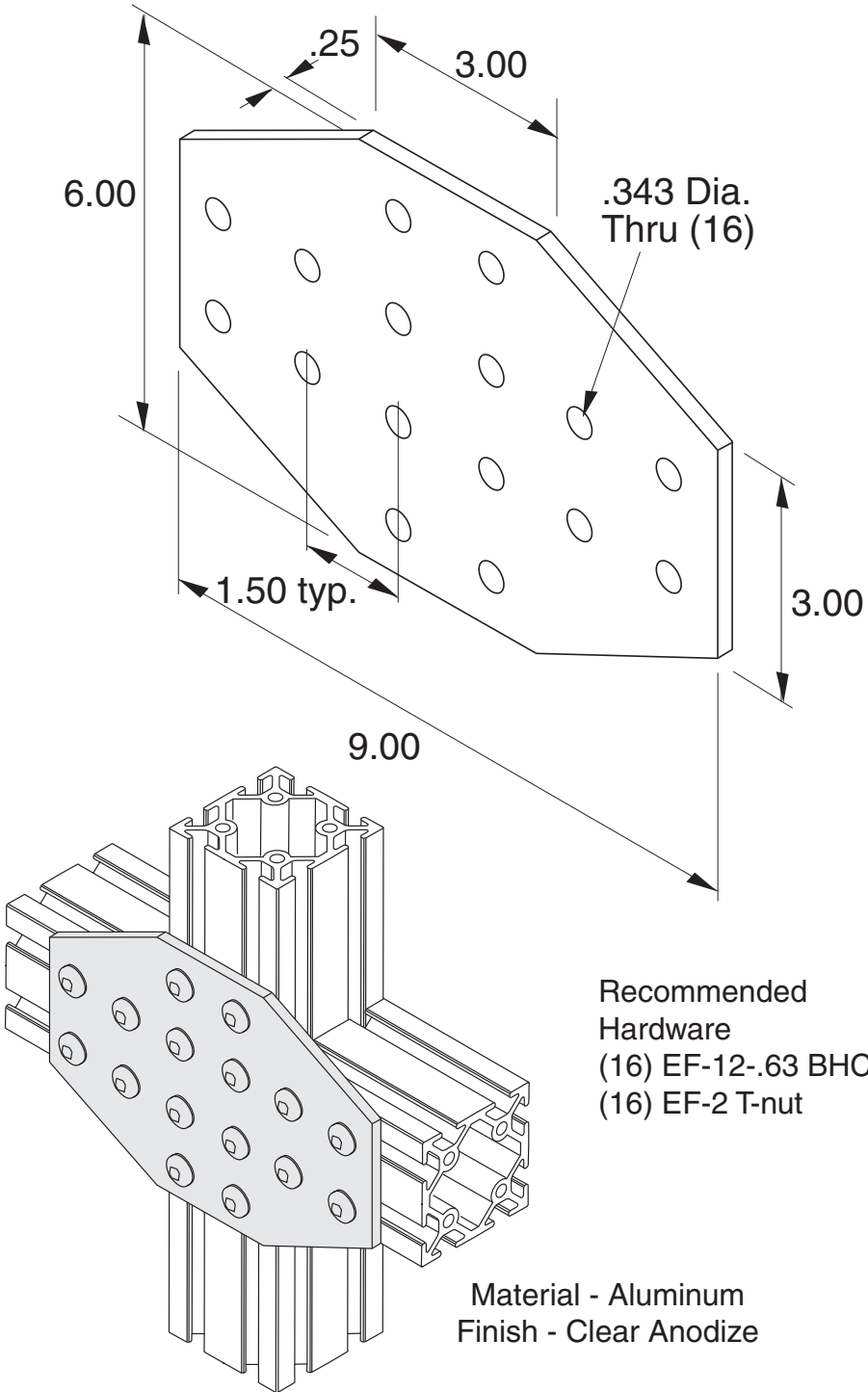

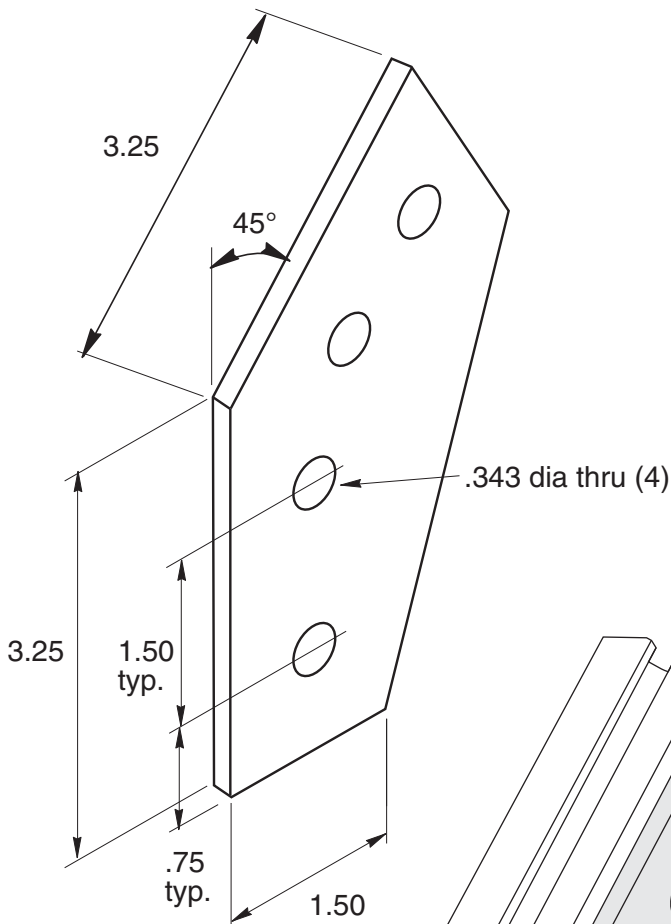

Recommended  
Hardware  
(4) EF-12-.63 BHCS  
(4) EF-2 T-nut

Material - Aluminum  
Finish - Clear Anodize

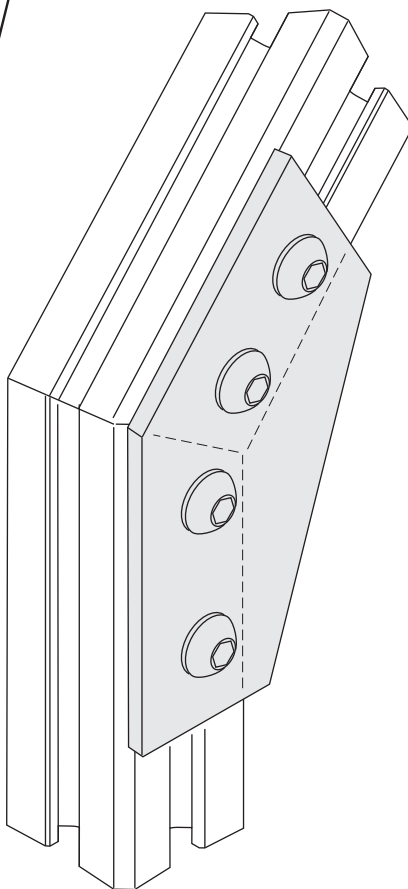

**5/16" SLOTS**

# 30° Joining Plate



**EB-125**

**5/16" SLOTS**

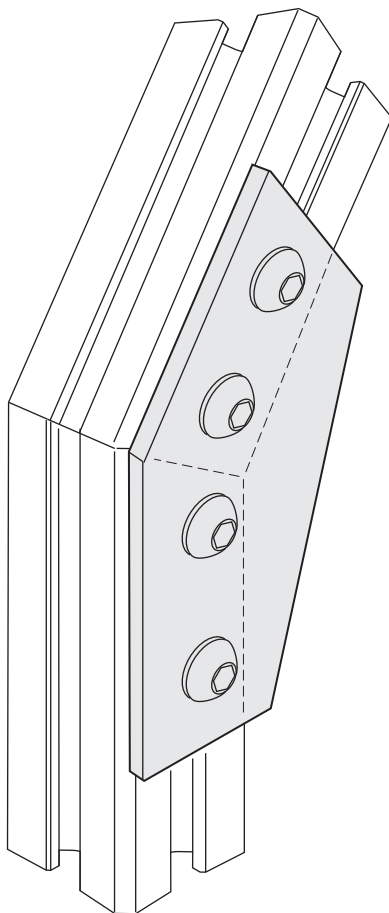
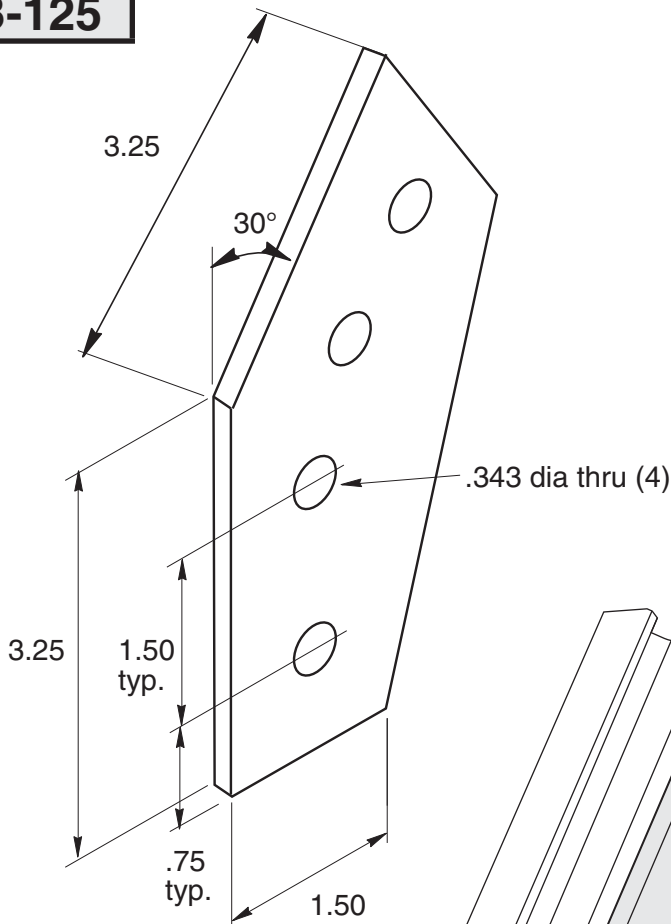

Recommended Hardware

(4) EF-12-.63 BHCS

(4) EF-2 T-nut

Material - Aluminum  
Finish - Clear Anodize

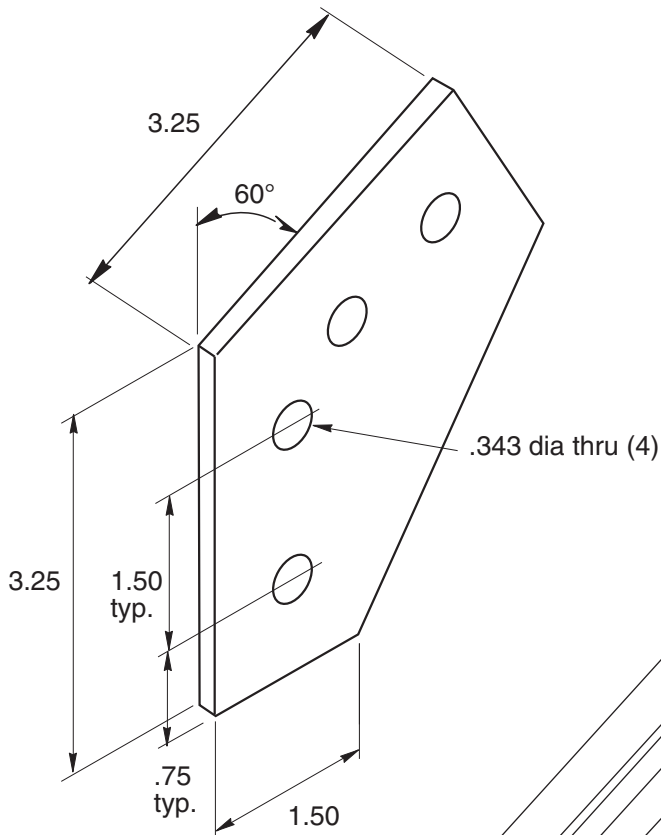

Recommended  
Hardware  
(4) EF-12-.63 BHCS  
(4) EF-2 T-nut

Material - Aluminum  
Finish - Clear Anodize

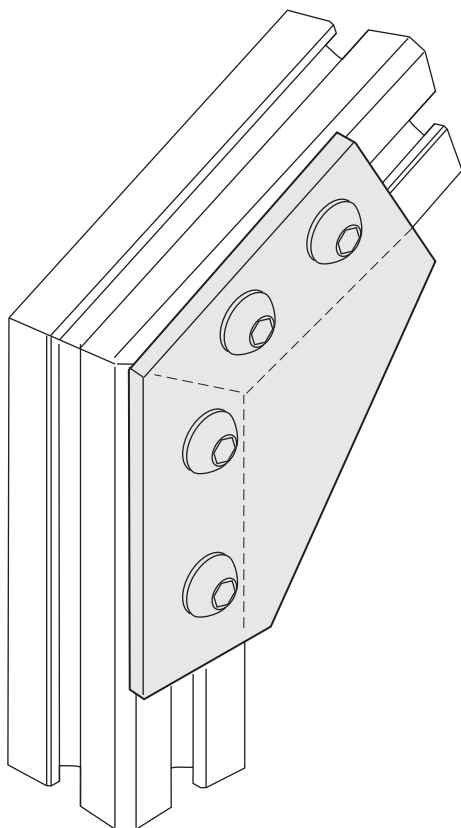

**5/16" SLOTS**



# 45° Joining Plate



**EB-127**

5/16" SLOTS

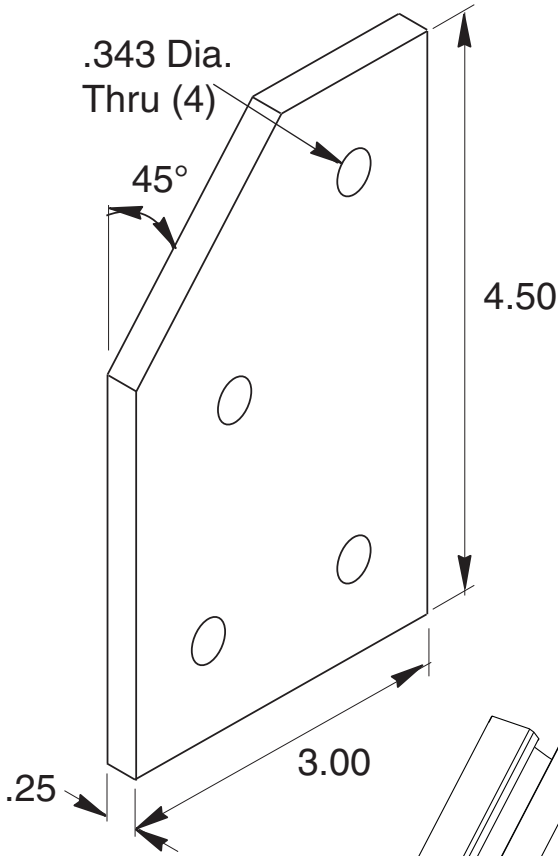

Recommended Hardware

- (4) EF-12-.63 BHCS
- (4) EF-2 T-nut

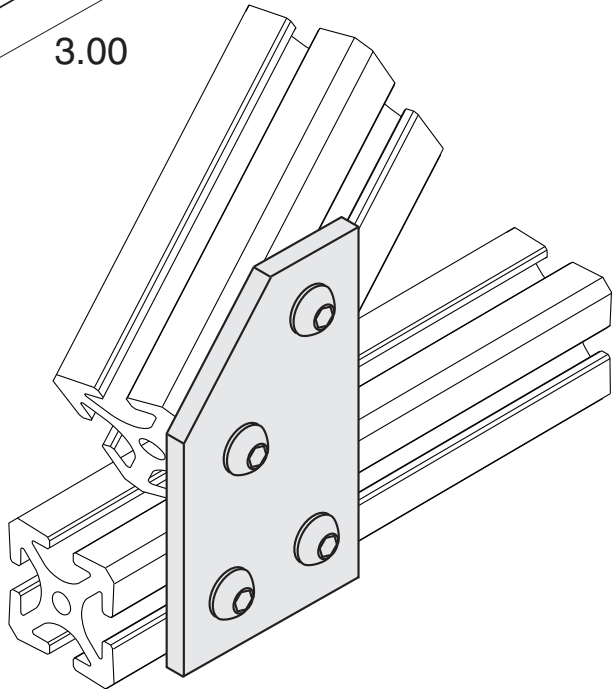

Material - Aluminum  
Finish - Clear Anodize

**EB-128**

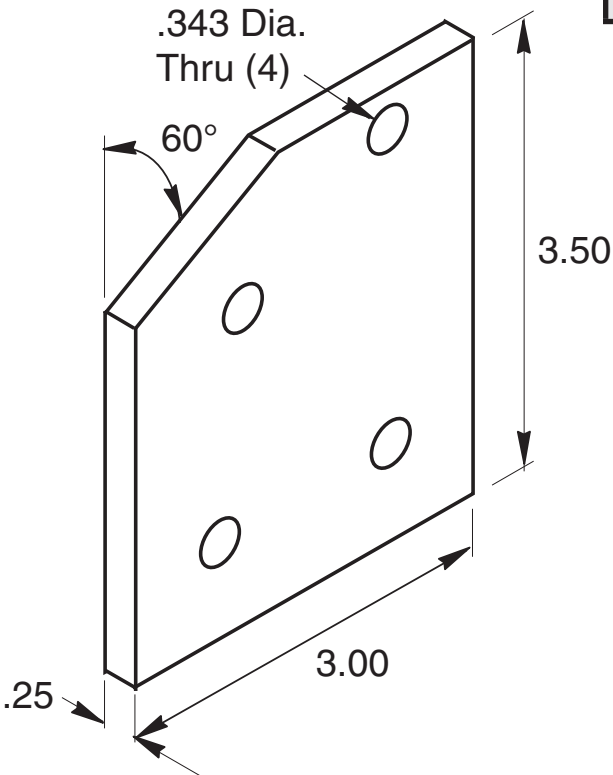

5/16" SLOTS

Recommended  
Hardware  
(4) EF-12-.63 BHCS  
(4) EF-2 T-nut

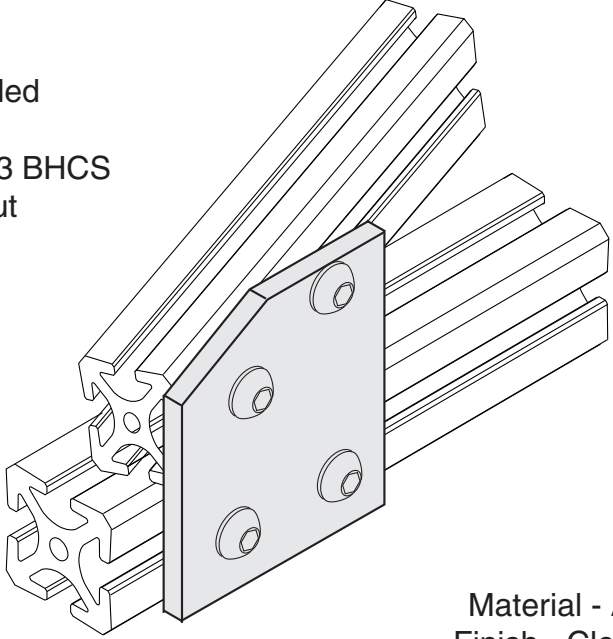

Material - Aluminum  
Finish - Clear Anodize

# 30° Joining Plate



**EB-129**

**5/16" SLOTS**

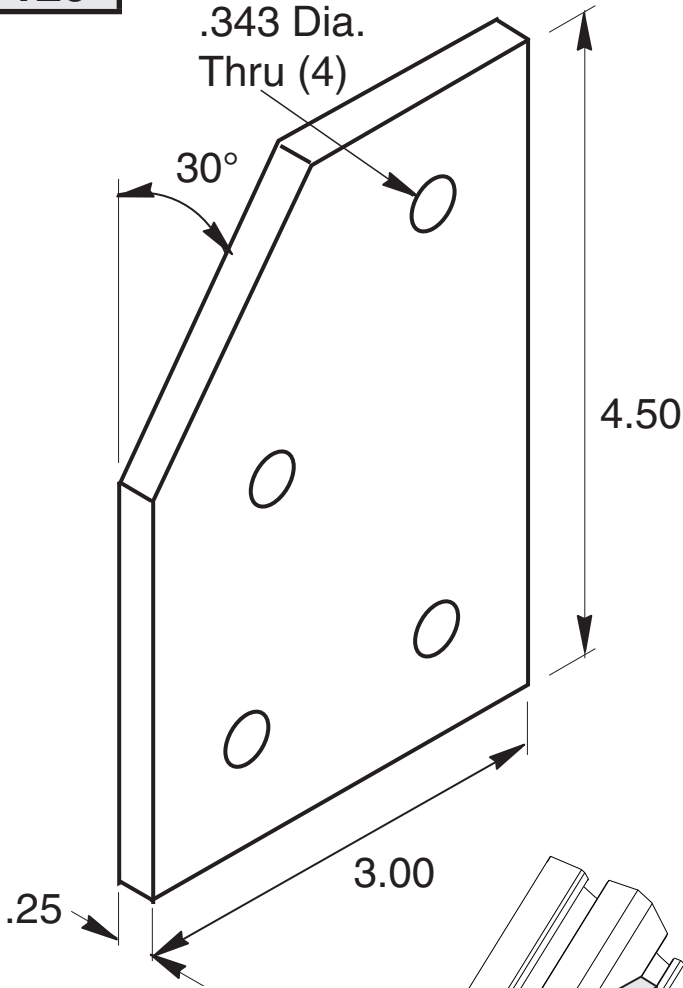

Recommended Hardware  
(4) EF-12-.63 BHCS  
(4) EF-2 T-nut

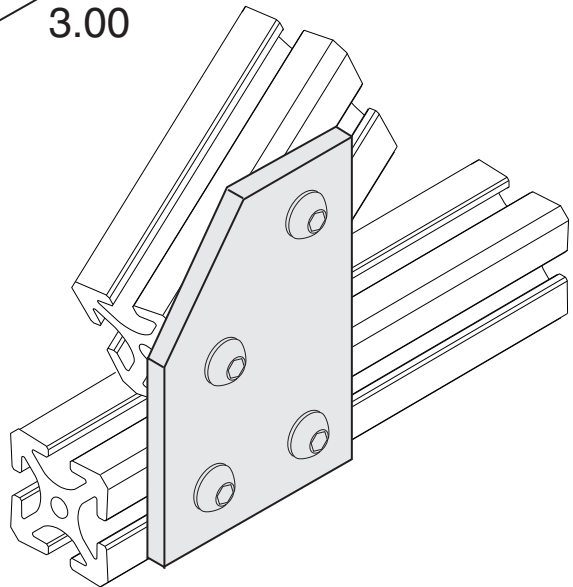

Material - Aluminum  
Finish - Clear Anodize

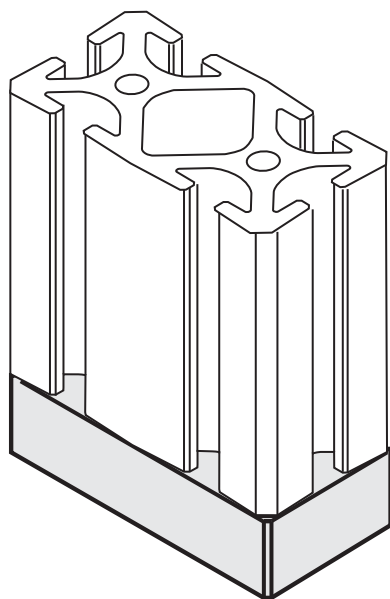

<b>EBP-1</b>
<b>EBP-1A</b>
<b>EBP-1B</b>
<b>EBP-1C</b>

**5/16" SLOTS**

- |               |                      |
|---------------|----------------------|
| <b>EBP-1</b>  | <b>thread</b> 1/2-13 |
| <b>EBP-1A</b> | 3/8-16               |
| <b>EBP-1B</b> | 5/8-11               |
| <b>EBP-1C</b> | 3/4-10               |

Drilled & C'Bored  
for 5/16 SHCS  
(2) plc's

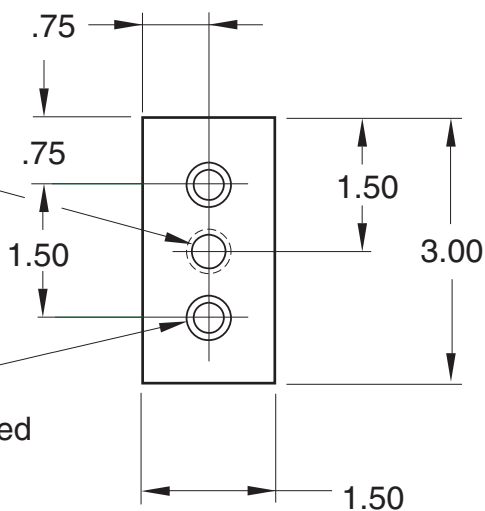

Requires  
(2) EF-11-1.0 SHCS

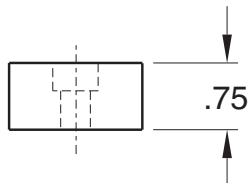

Material - Aluminum  
Finish - Clear Anodize

# Leveling Plate



<b>EBP-2</b>
<b>EBP-2A</b>
<b>EBP-2B</b>
<b>EBP-2C</b>

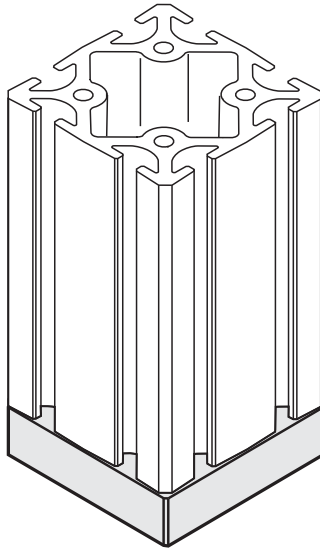

**5/16" SLOTS**

<b>EBP-2</b>	<b>thread</b> 1/2-13
<b>EBP-2A</b>	3/8-16
<b>EBP-2B</b>	5/8-11
<b>EBP-2C</b>	3/4-10

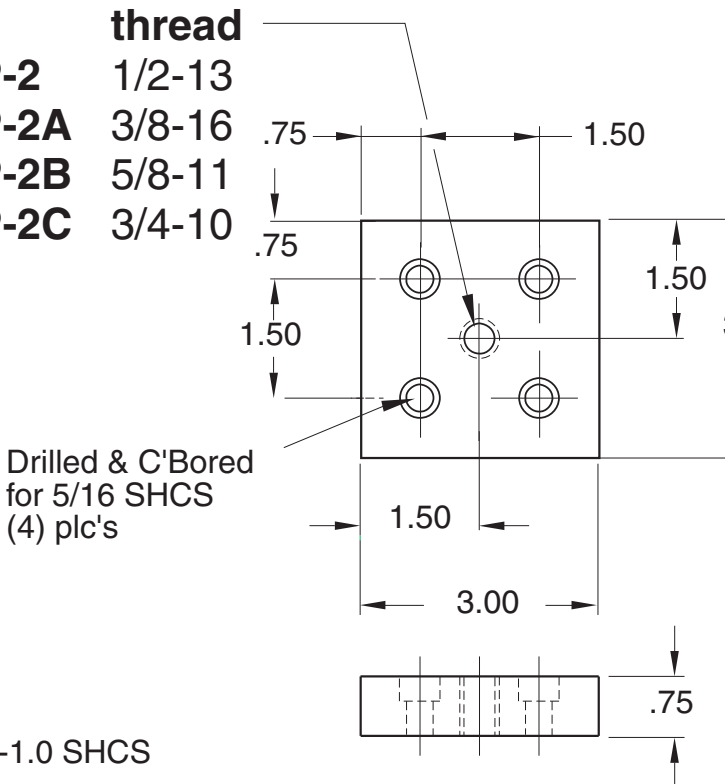

Requires  
(4) EF-11-1.0 SHCS

Material - Aluminum  
Finish - Clear Anodize

<b>EBP-3</b>
<b>EBP-3A</b>
<b>EBP-3B</b>
<b>EBP-3C</b>

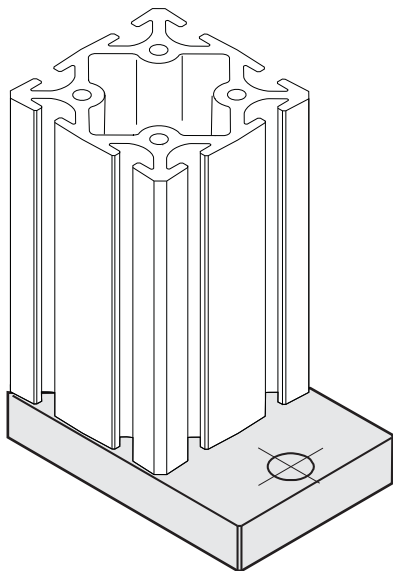

**5/16" SLOTS**

<b>EBP-3</b>	<b>thread</b>	<b>1/2-13</b>
<b>EBP-3A</b>	<b>3/8-16</b>	
<b>EBP-3B</b>	<b>5/8-11</b>	
<b>EBP-3C</b>	<b>3/4-10</b>	

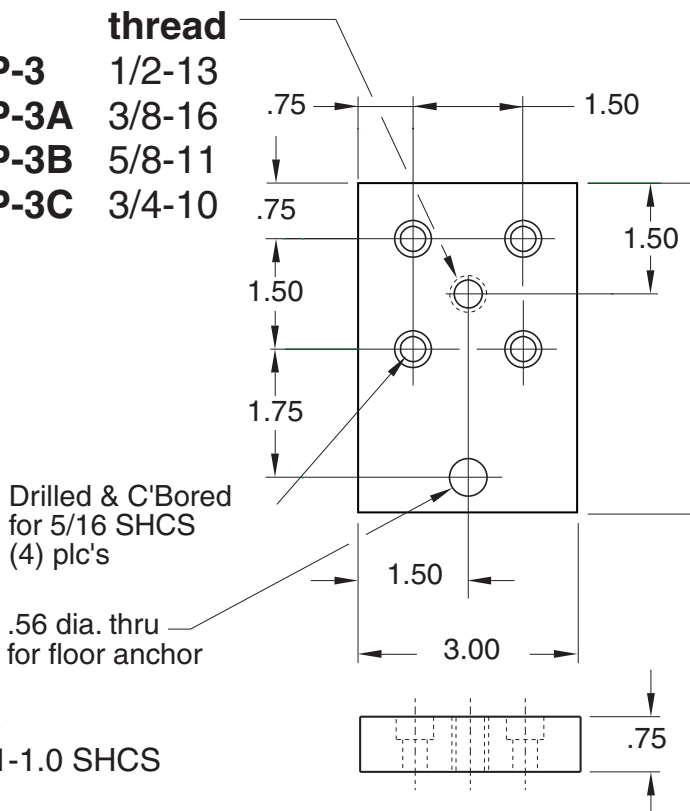

**Material - Aluminum**  
**Finish - Clear Anodize**

# Leveling Anchor Plate



<b>EBP-4</b>
<b>EBP-4A</b>
<b>EBP-4B</b>
<b>EBP-4C</b>

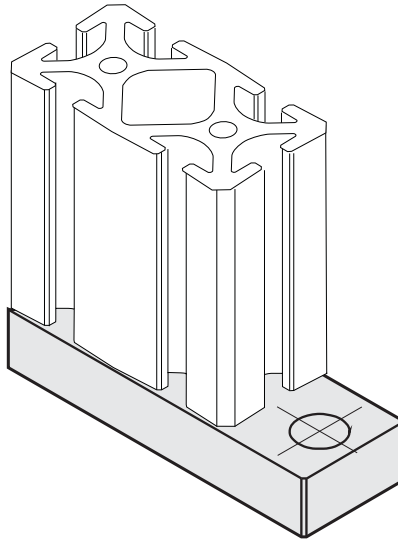

**5/16" SLOTS**

	<b>thread</b>
<b>EBP-4</b>	1/2-13
<b>EBP-4A</b>	3/8-16
<b>EBP-4B</b>	5/8-11
<b>EBP-4C</b>	3/4-10

Drilled & C'Bored  
for 5/16 SHCS  
(2) plc's

.56 dia. thru  
for floor anchor

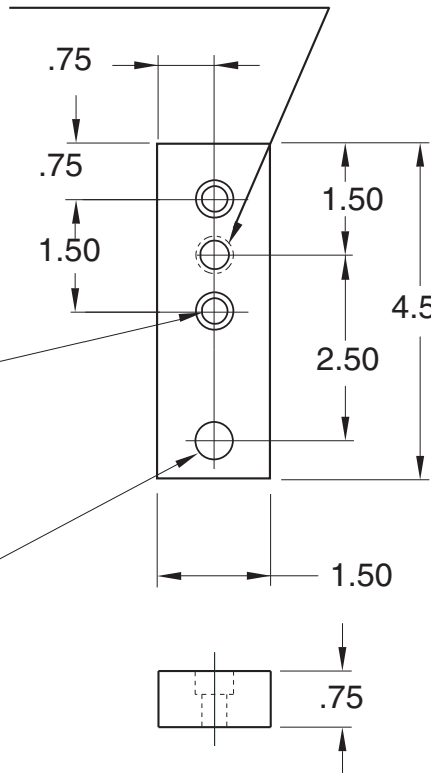

Requires  
(2) EF-11-1.0 SHCS

Material - Aluminum  
Finish - Clear Anodize

<b>EBP-6</b>
<b>EBP-6A</b>
<b>EBP-6B</b>
<b>EBP-6C</b>

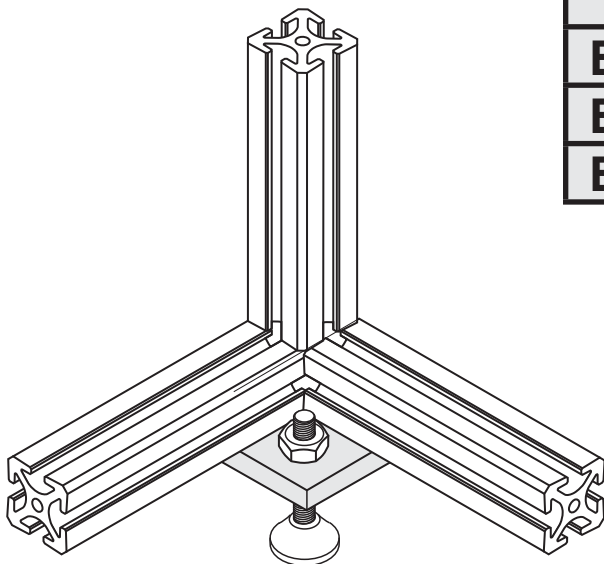

**5/16" SLOTS**

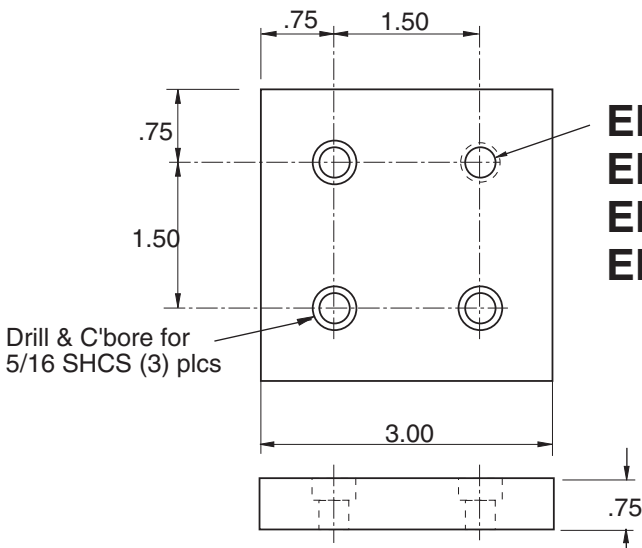

	<b>thread</b>
<b>EBP-6</b>	1/2-13
<b>EBP-6A</b>	3/8-16
<b>EBP-6B</b>	5/8-11
<b>EBP-6C</b>	3/4-10

Requires  
 (3) EF-11-.875 SHCS  
 (3) EF-2 T-nut

Material - Aluminum  
 Finish - Clear Anodize



**EBP-8**

**5/16" SLOTS**

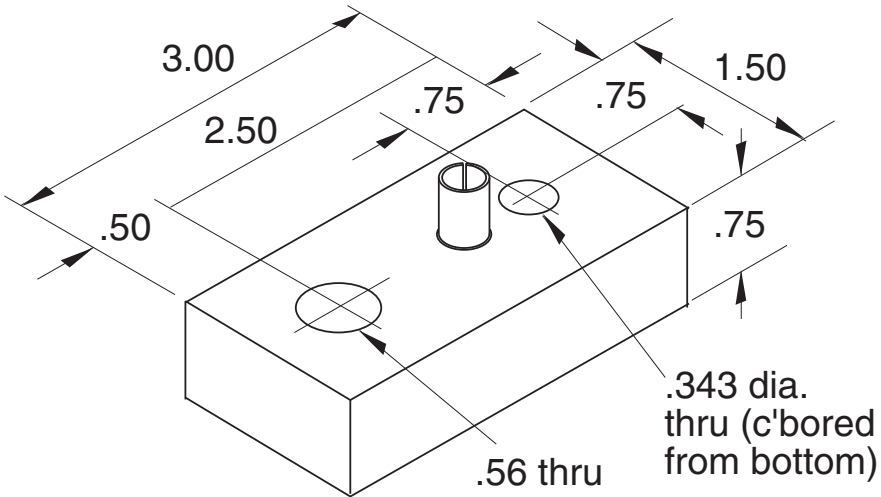
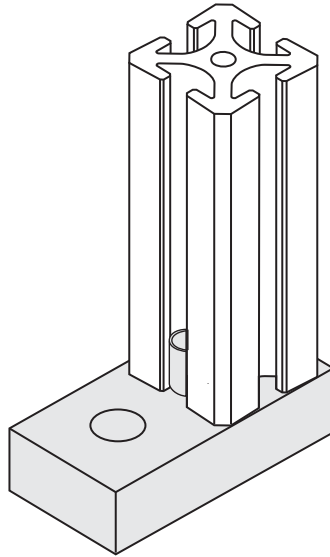

Requires  
(1) EF-11-1.0 SHCS

Material - Aluminum  
Finish - Clear Anodize

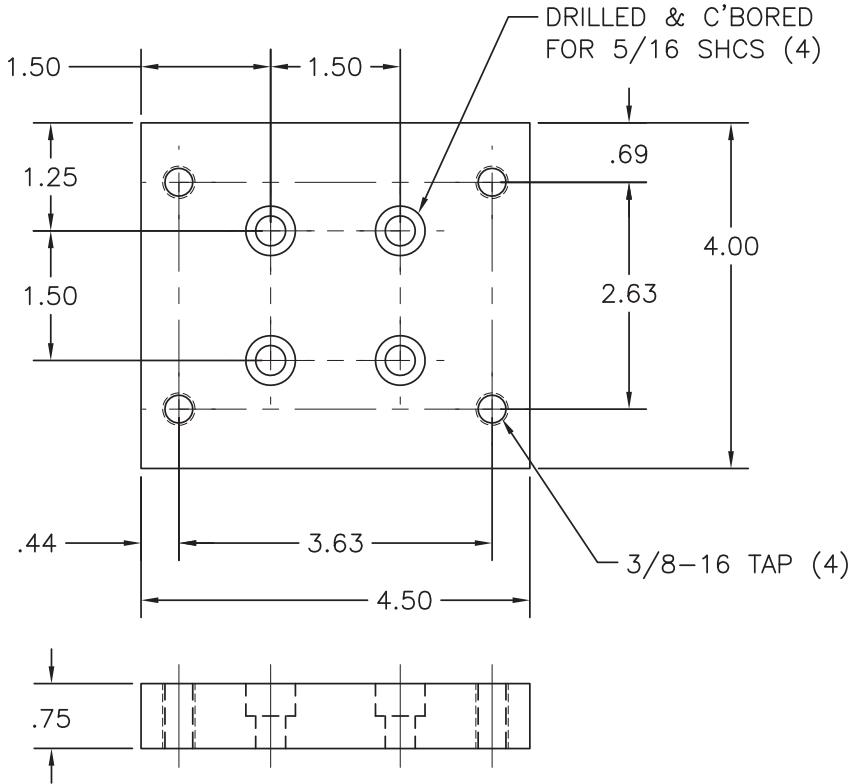

**5/16" SLOTS**

**Recommended Hardware**  
 (4) EF-11.75  
 (4) EF-1

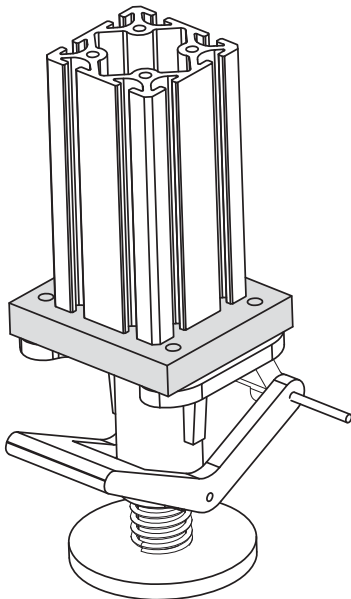

**Material - Steel**  
**Finish - Zinc Coated**

**EAL**

**EAL-1**

5/16" SLOTS

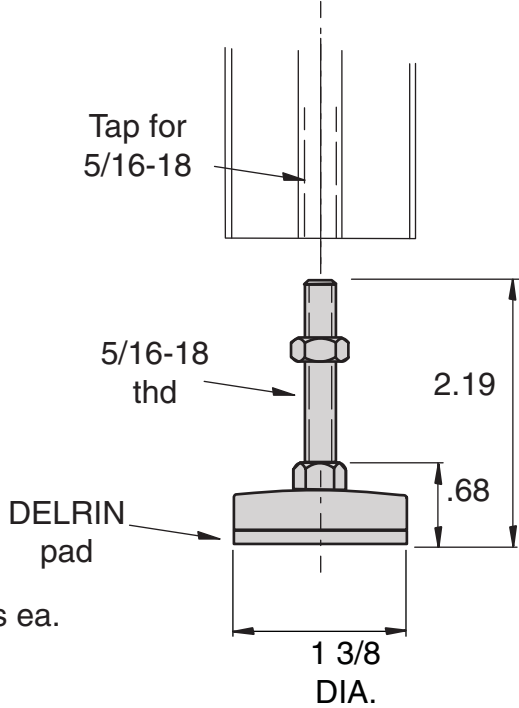

Max load = 250 lbs ea.

**EAL-2**

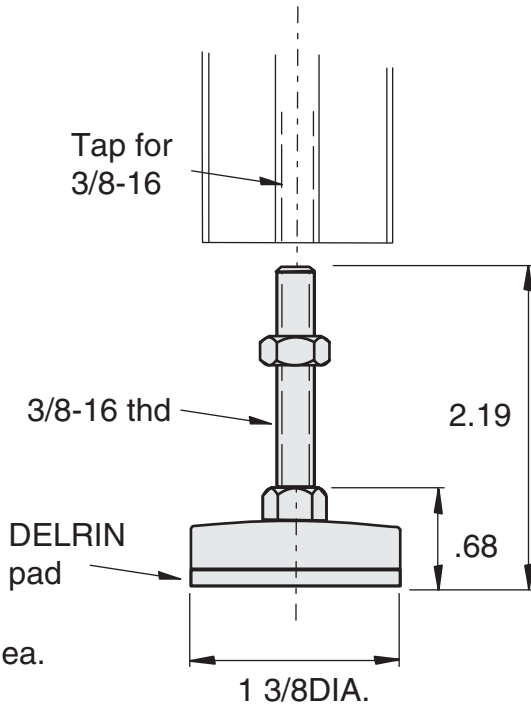

Max load = 400 lbs ea.

**EAL-E**

**EAL-E1**

Max load = 1700 lbs ea.

Tap for  
5/16-18

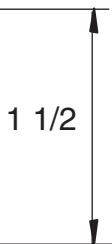
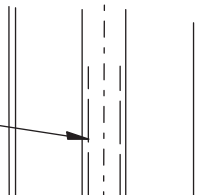

5/16-18 thd

Material - Steel  
Finish - Zinc Plated

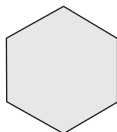

**5/16" SLOTS**

**EAL-E2**

Max load = 1700 lbs ea.

Tap for  
3/8-16

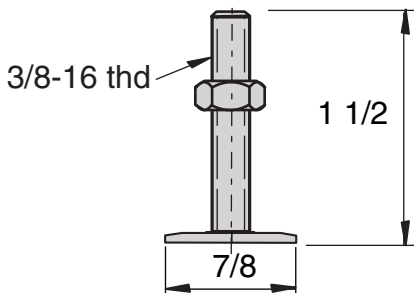
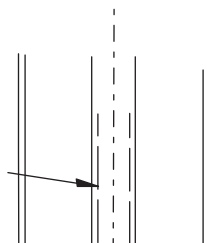

3/8-16 thd

Material - Steel  
Finish - Zinc Plated

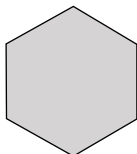

# Adjustable Leg (Economy)



**EAL-E**

**EAL-E3**

5/16" SLOTS

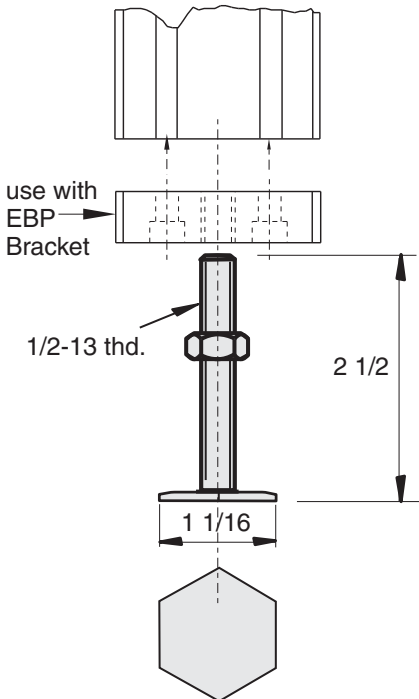
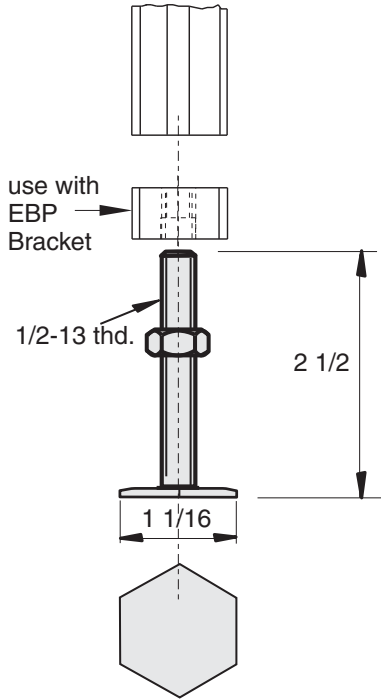

Max load = 4200 lbs ea.

Material - Steel  
Finish - Zinc Plated

<b>EAL-3</b>
<b>EAL-4</b>
<b>EAL-5</b>
<b>EAL-6</b>
<b>EAL-10</b>

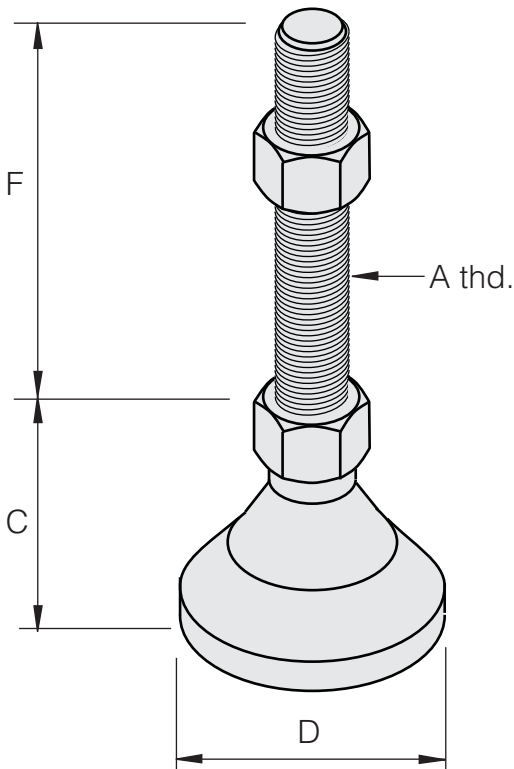

**5/16" SLOTS**

Part No	Max (lbs) Work Load	A	C	D	F
<b>EAL-4</b>	3750	3/8-16	7/8	1 1/4	2
<b>EAL-3</b>	5000	1/2-13	1 1/8	1 7/8	2
<b>EAL-5</b>	6000	5/8-11	1 1/4	2 1/2	2
<b>EAL-6</b>	7200	3/4-10	1 1/2	3	2
<b>EAL-10</b>	2300	5/16-18	1.25	1 1/4	2

**Material - Steel**  
**Finish - Yellow Zinc Plate**

<b>EAL-7</b>
<b>EAL-8</b>
<b>EAL-9</b>

**5/16" SLOTS**

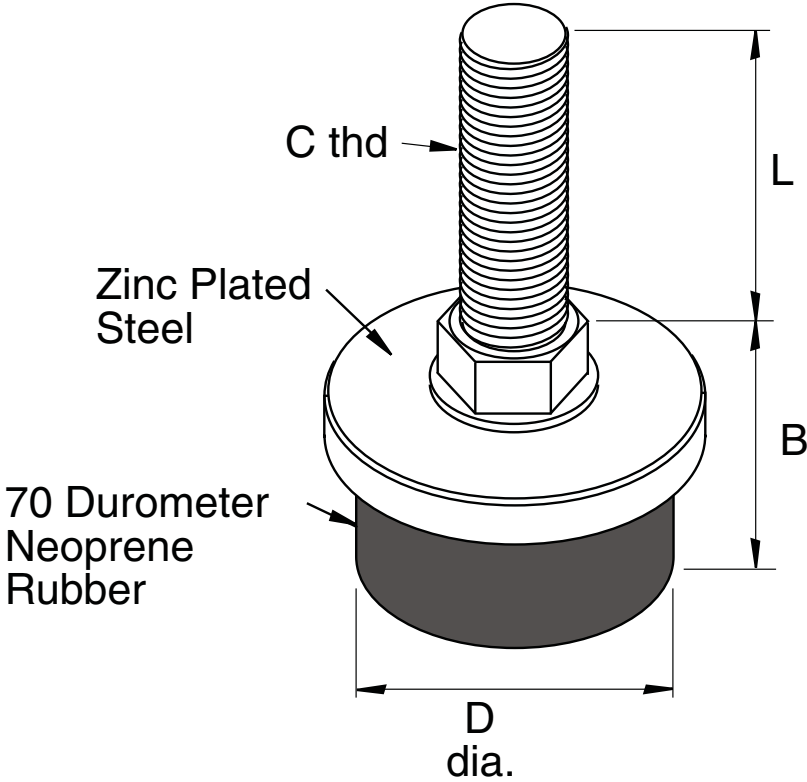

Part No	Max (lbs) Work Load	C Thd Size	D	B	L
<b>EAL-7</b>	100	$5/16$ -18	1.0	$13/16$	$1\ 1/4$
<b>EAL-8</b>	300	$3/8$ -16	1.5	$63/64$	3.0
<b>EAL-9</b>	300	$1/2$ -13	1.5	$1\ 1/16$	2.0

**EC-S1**

**EC-S2**

**EC-S3**

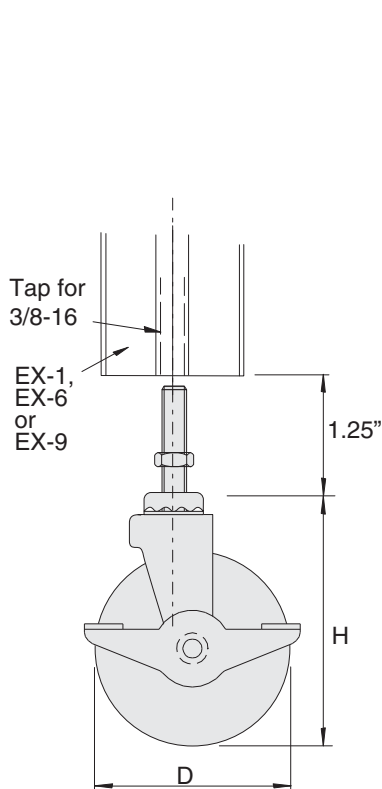

**EC-S1**  
**EC-S2**

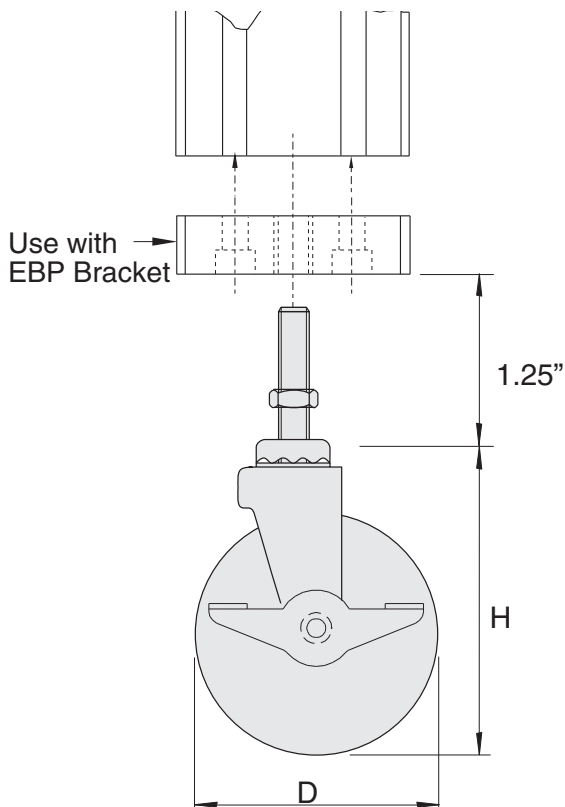

**EC-S3**

**5/16" SLOTS**

Note: Wheel material is hard plastic

Part no.	D	H	Stem	Brake	Max. Load	Wheel Width
<b>EC-S1</b>	2	2 <sup>5</sup> / <sub>8</sub>	3/8-16 x 1 1/4	Yes	125 lbs	1.00
<b>EC-S2</b>	3	3 <sup>3</sup> / <sub>4</sub>	3/8-16 x 1 1/4	Yes	250 lbs	1.25
<b>EC-S3</b>	4	5	1/2-13 x 1 1/2	Yes	300 lbs	1.25



# Fixed Plate Caster



<b>EC-3F</b>
<b>EC-4F</b>
<b>EC-5F</b>

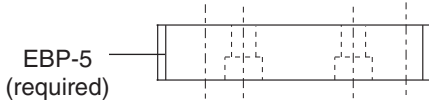
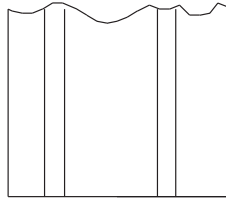

The casters have (4) .343 dia  
mtg holes on 1 3/4" x 3.00" centers

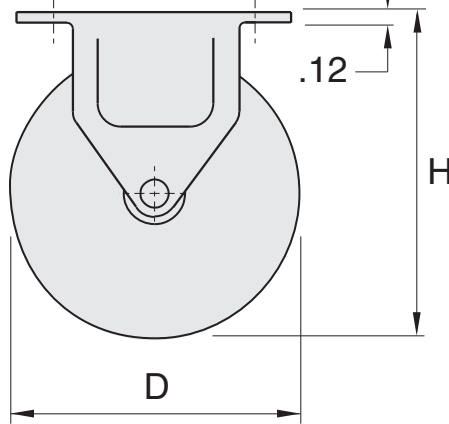

EX-3 uses caster plate EBP-5

Recommended Hardware  
(4) EF-11.63 BHCS

Note: Wheel material is hard plastic

Part no.	D	H	Brake	Max. Load	Wheel Width
<b>EC-3F</b>	3	4.13	No	250 lbs	1.25
<b>EC-4F</b>	4	5.00	No	300 lbs	1.25
<b>EC-5F</b>	5	6.00	No	325 lbs	1.25

5/16" SLOTS

**EC-3S**

**EC-4S**

**EC-5S**

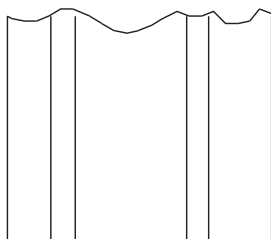

EX-3 uses caster plate EBP-5

EBP-5  
(required)

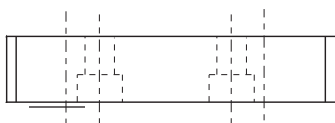

Recommended Hardware  
(4) EF-12.63 BHCS

The casters have (4) .343 dia  
mtg holes on 1 3/4" x 3.00" centers

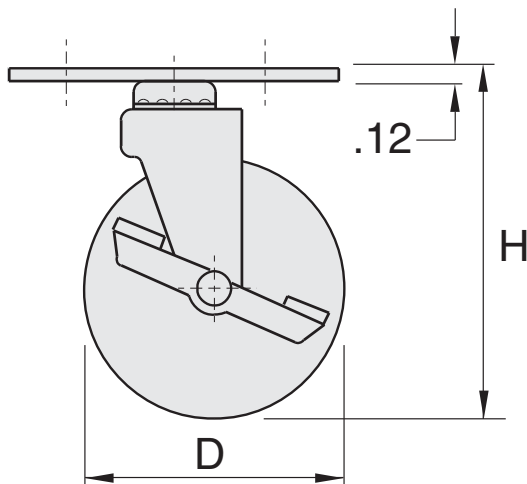

Note: Wheel material is hard plastic

Part no.	D	H	Brake	Max. Load	Wheel Width
<b>EC-3S</b>	3	4.13	Yes	250 lbs	1.25
<b>EC-4S</b>	4	5.00	Yes	300 lbs	1.25
<b>EC-5S</b>	5	6.00	Yes	325 lbs	1.25

**5/16" SLOTS**

# Total Lock Swivel Plate Caster



## ECT-4S

5/16" SLOTS

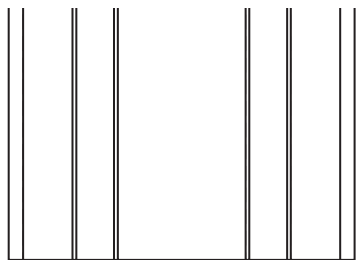

Locking Mechanism  
Locks  
Wheel Rotation  
and Swivel

EX-3 USES CASTER PLATE EBP-5  
REQUIRED HARDWARE  
(4) EF-12-.63 SHCS

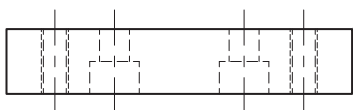

The Casters Have (4)  $\varnothing$ .343 Mounting Holes  
on 1 3/4" x 2 7/8" Centers

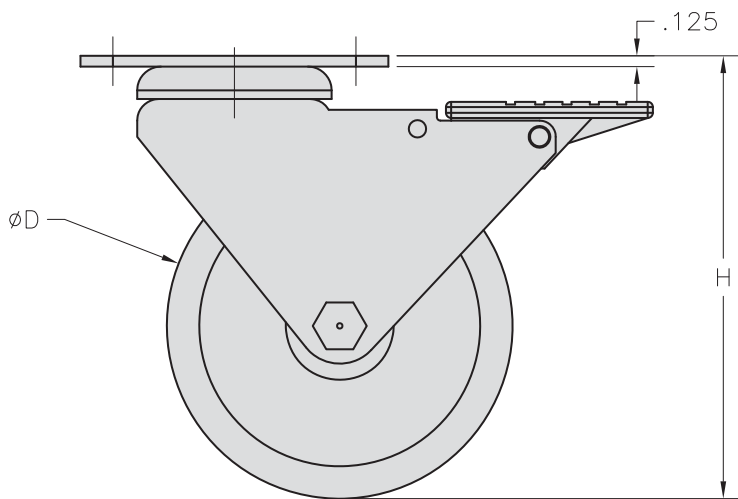

Note: Wheel Material is Grey Polyurethane

PART NO	$\varnothing$ D	H	BRAKE	MAX LOAD	WHEEL WIDTH
ECT-4S	4.00	5.13	YES	250 lbs	1.25

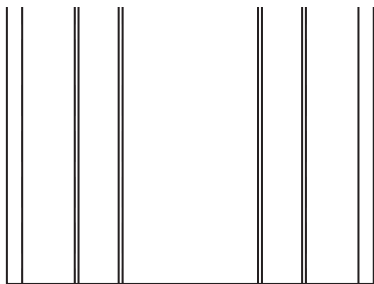

EX-3 USES CASTER PLATE EBP-5  
REQUIRED HARDWARE  
(4) EF-12-.63 SHCS

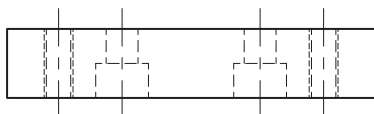

The Casters Have (4) Ø.343 Mounting Holes  
on 1 3/4" x 2 7/8" Centers

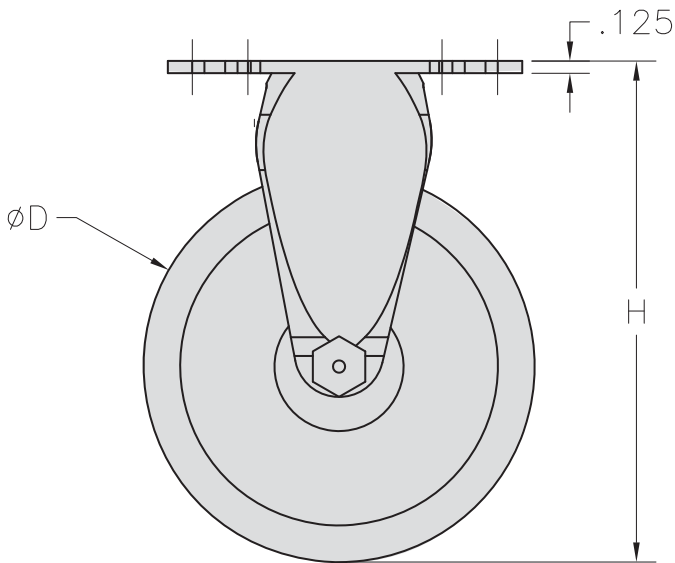

Note: Wheel Material is Grey Polyurethane

PART NO	ØD	H	BRAKE	MAX LOAD	WHEEL WIDTH
ECT-4F	4.00	5.13	NO	250 lbs	1.25

# Caster Mounting Plate



## EBP-5 for Plate Casters

5/16" SLOTS

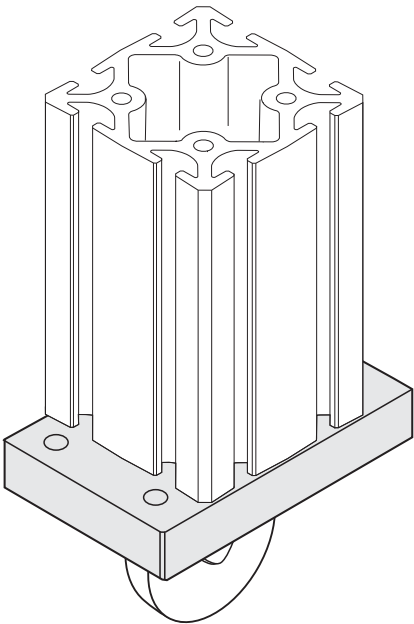
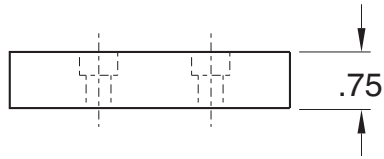
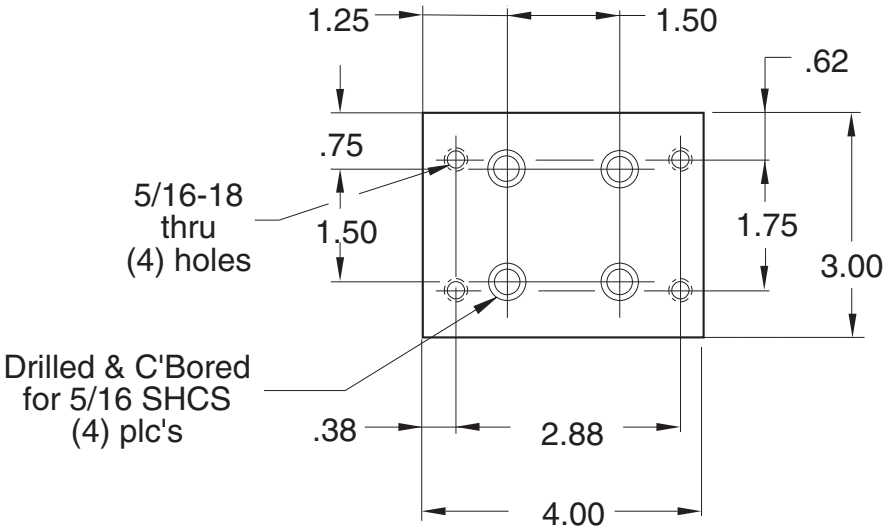

Requires  
(4) EF-11-1.0 SHCS

Material - Aluminum  
Finish - Clear Anodize

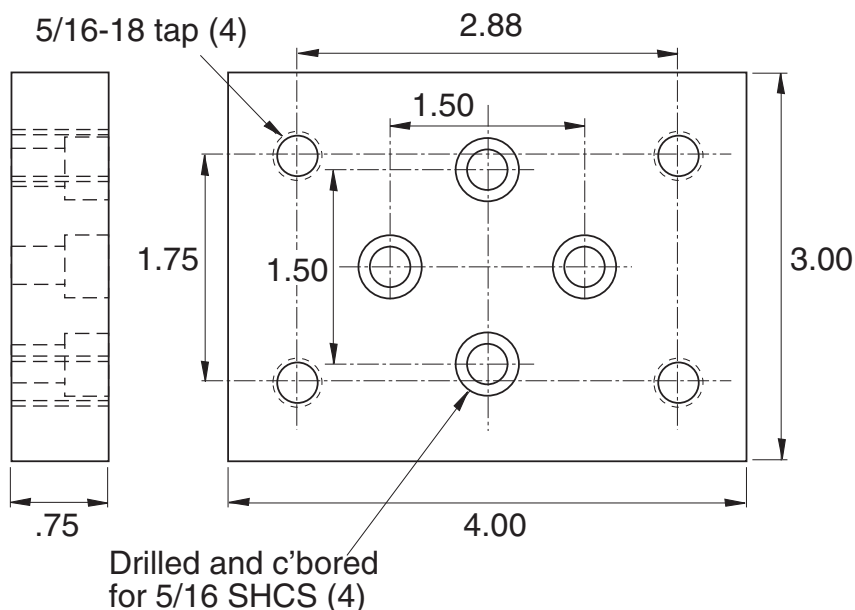

**5/16" SLOTS**

- Requires
- (2) EF-11-.75 SHCS
  - (2) EF-2 T-nut

Note: Plate can be rotated 90°

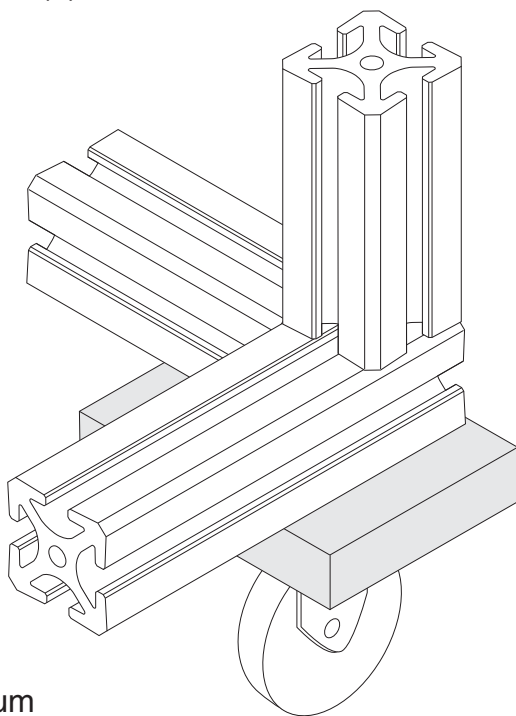

Material - Aluminum  
Finish - Clear Anodize

# Floor Locks



<b>EB-151</b>
<b>EB-153</b>

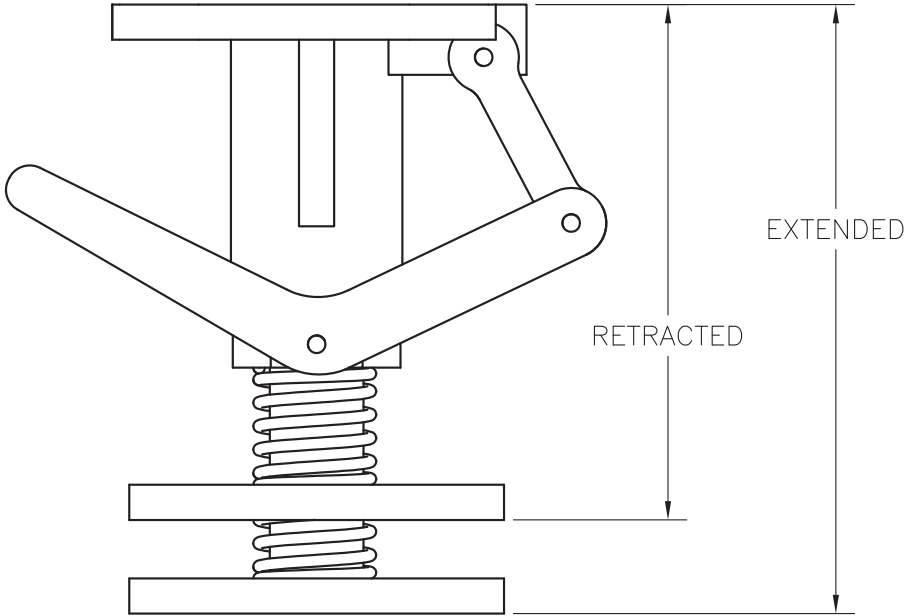

Top Plate Dimension - 4.0" x 4.0"  
 Bolt Diameter - Ø.375"  
 Mounting Hole Centerline - 2.625" x 3.625"  
 (4) 3/8-16 x 5/8" BHCS Included  
 Use EB-154 Mounting Plate for 5/16" Slot Extrusions.

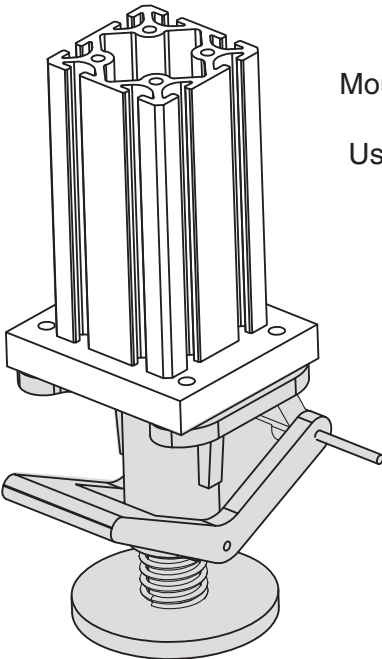

PART NO	RETRACTED	EXTENDED
<b>EB-151</b>	5 1/16"	5 5/8"
<b>EB-153</b>	6 3/4"	7 3/4"

New Stuff

**5/16" SLOTS**

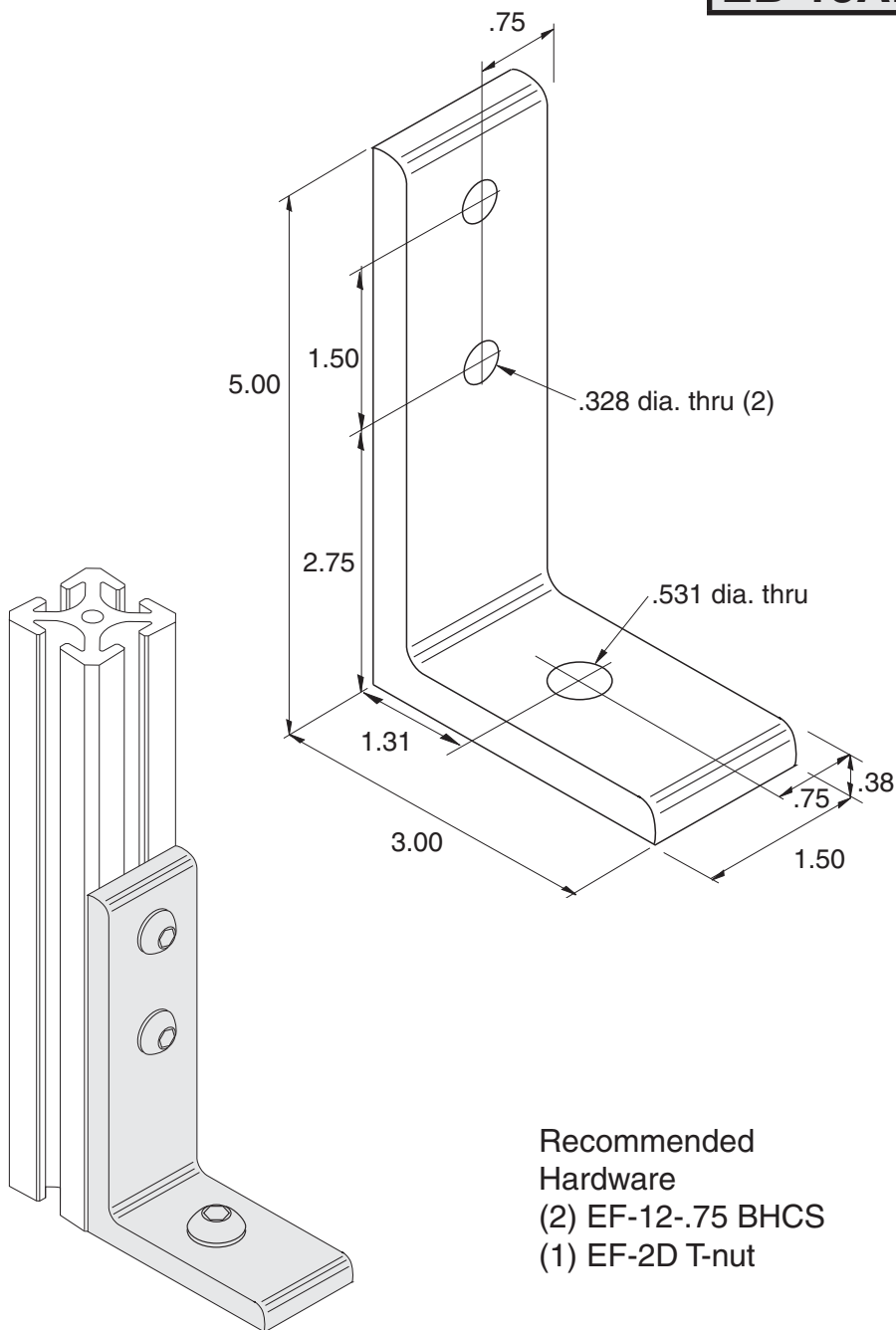

**Recommended  
Hardware**  
(2) EF-12-.75 BHCS  
(1) EF-2D T-nut

**Material - Aluminum  
Finish - Clear Anodize**



# Economy Aluminum Floor Mount



**EB-15AL3**

**5/16" SLOTS**

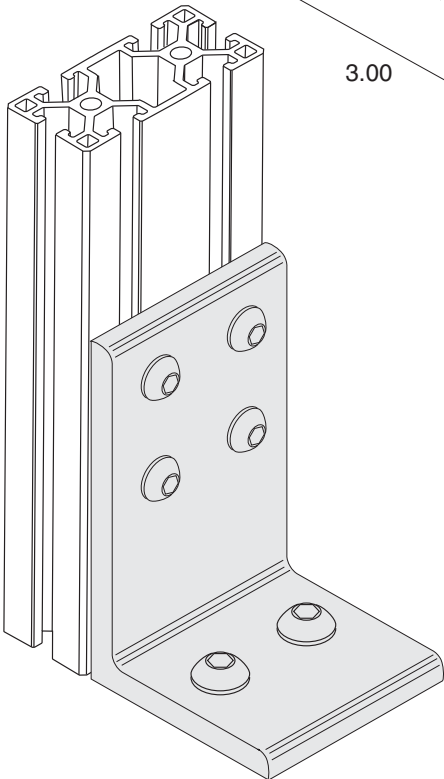
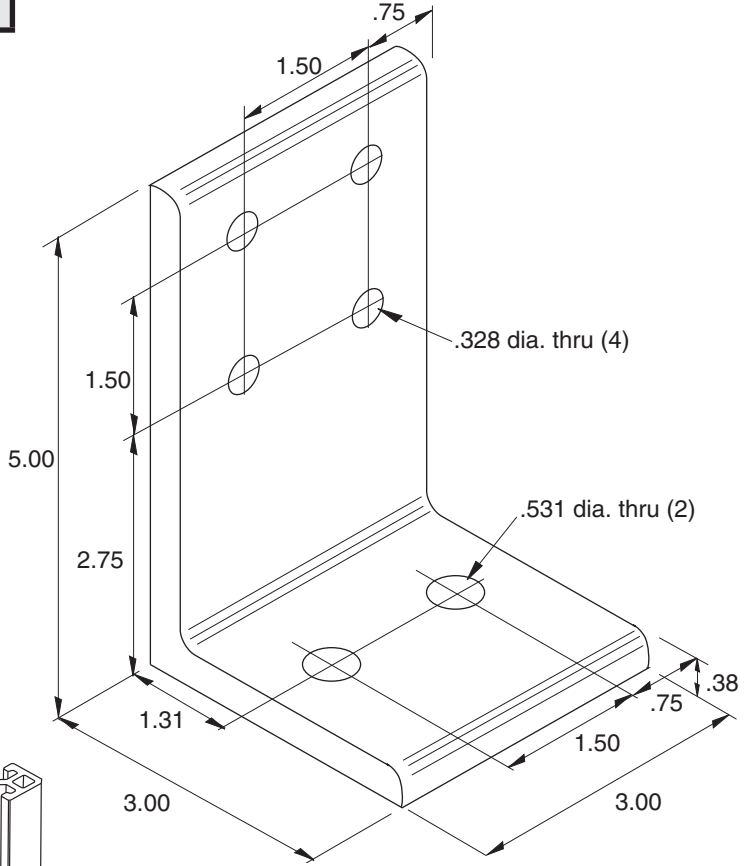

Recommended  
Hardware  
(4) EF-12-.75 BHCS  
(2) EF-2D T-nut

Material - Aluminum  
Finish - Clear Anodize

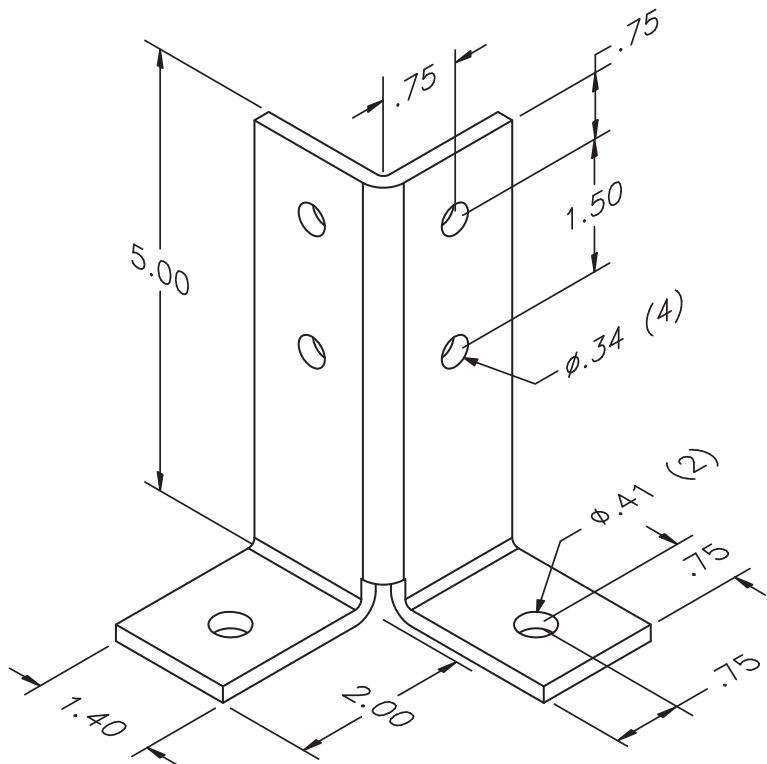

.200" thick

Use with 5/16" slot extrusions

- Recommended Hardware**  
 (4) EF-12-.63 BHCS  
 (2) EF-2D T-nut

**Material - Steel**  
**Finish - Grey Powder Coat**

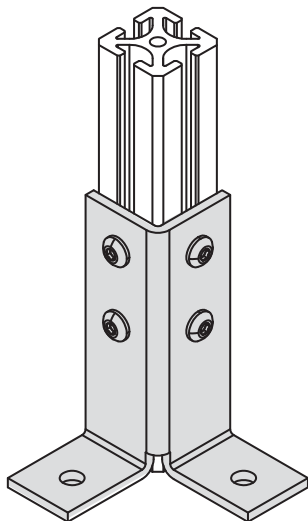

**5/16" SLOTS**

# Adjustable Leveling Foot



**EB-70**

**5/16" SLOTS**

Hardware for Mounting to Extrusion Included

Use with 5/16" slot Extrusions

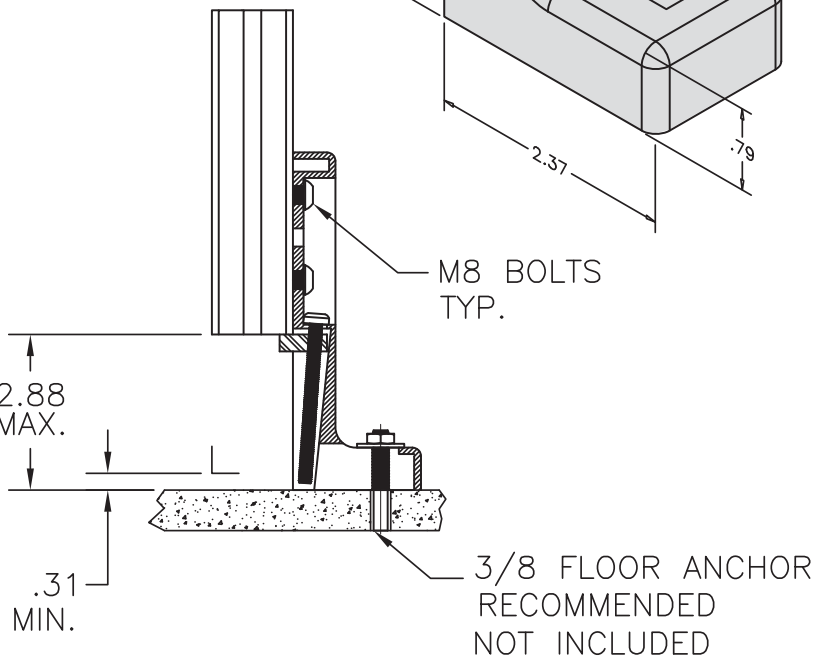
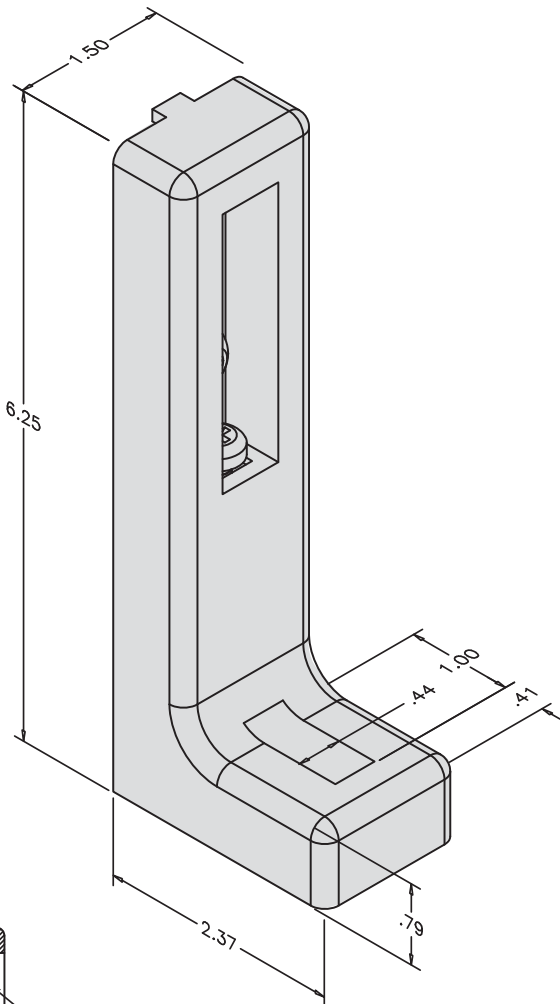

**Material - Die Cast Zinc**  
**Finish - Black Powder Coat**

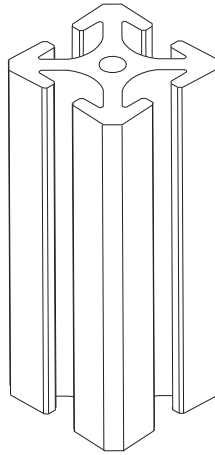

use with  
1.5" square profiles

**5/16" SLOTS**

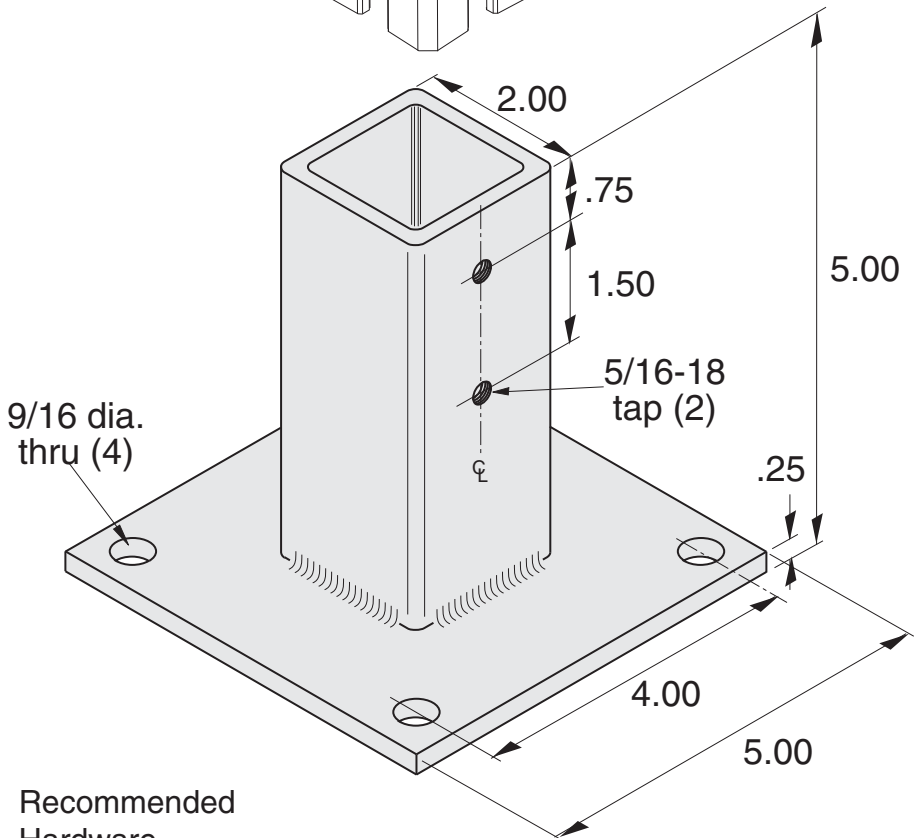

Recommended  
Hardware  
(2) EF-11-1.0 BHCS

Material - Steel  
Finish - Black Powder Coat

# Steel Flanged Foot



**EB-42**

**5/16" SLOTS**

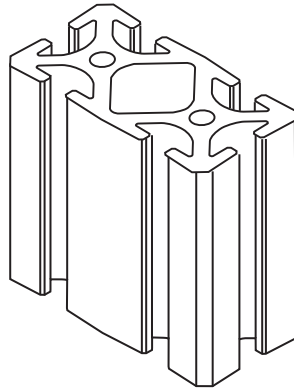

use with  
1.5" x 3" profiles

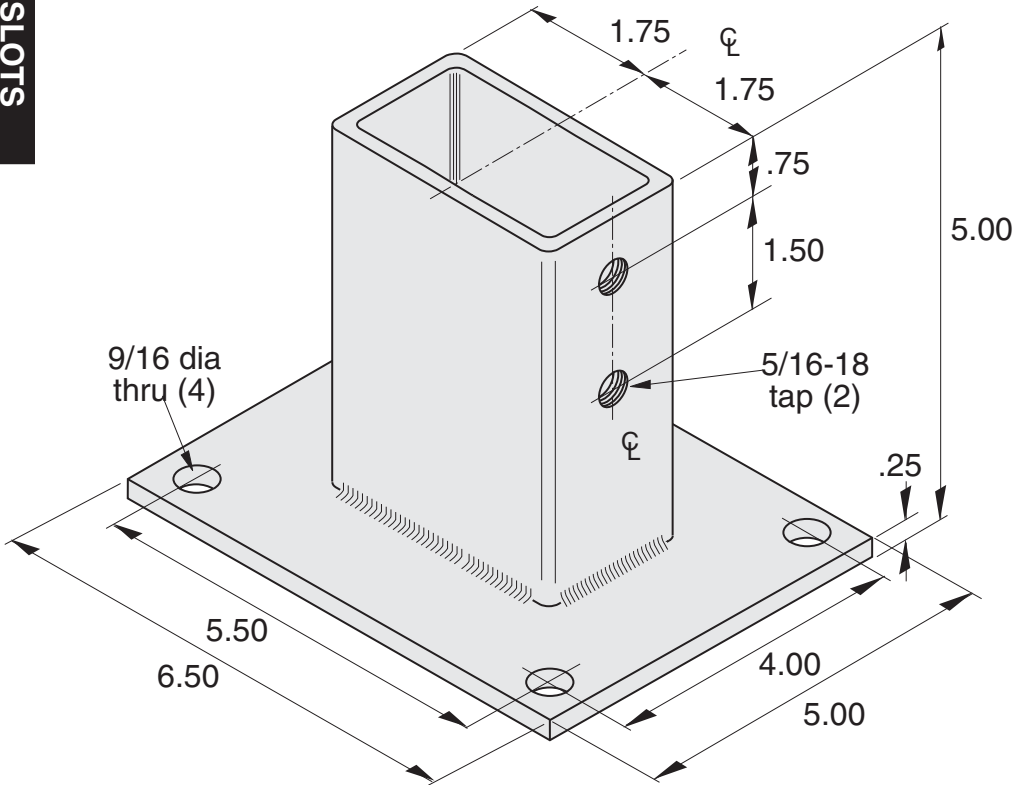

Recommended  
Hardware  
(2) EF-11-1.0 SHCS

Material - Steel  
Finish - Black Powder Coat

**EB-43**

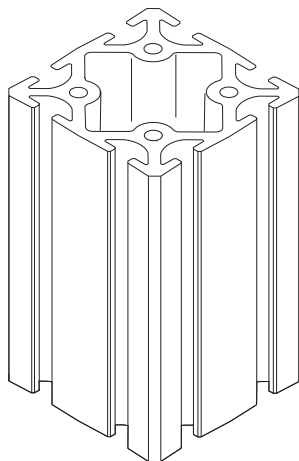

use with  
EX-3 or EX-37

**5/16" SLOTS**

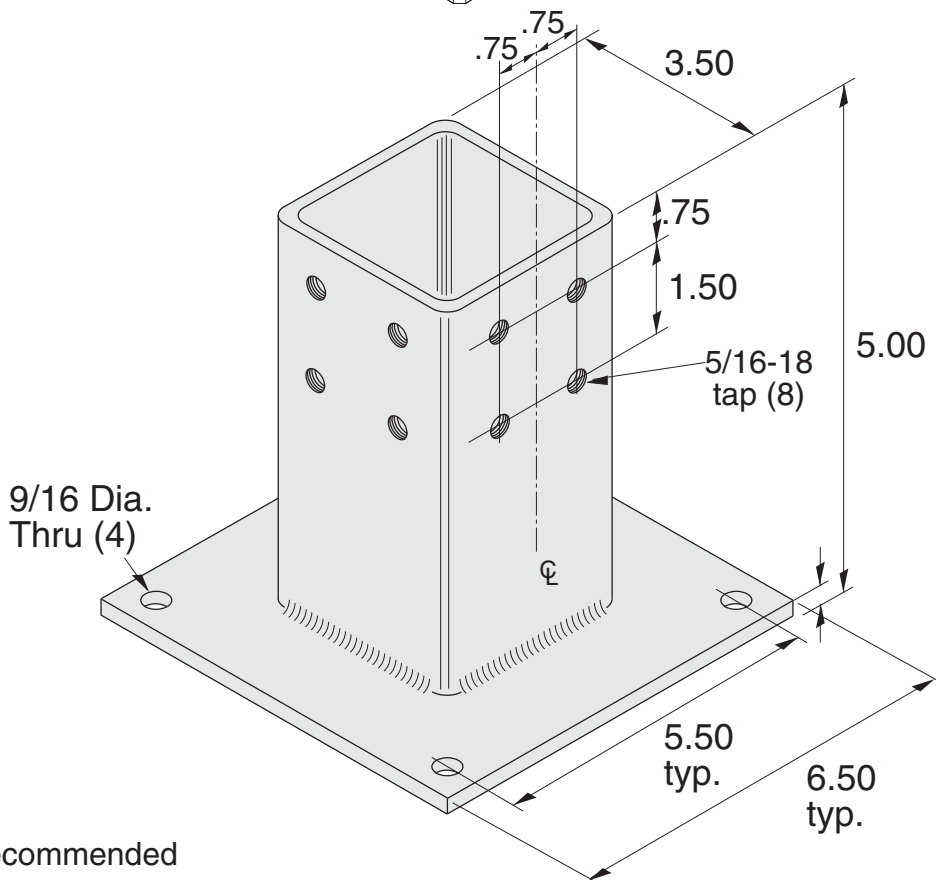

Recommended  
Hardware  
(4) EF-11-1.0 BHCS

Material - Steel  
Finish - Black Powder Coat

<b>EB-38-1/2</b>	16 gage wire 1/2"x 1/2" opening - Black
<b>EB-38-1/2Y</b>	16 gage wire 1/2"x 1/2" opening - Yellow
<b>EB-38-1</b>	12 gage wire 1"x1" opening - Black
<b>EB-38-1Y</b>	12 gage wire 1"x1" opening - Yellow
<b>EB-38-2</b>	12 gage wire 2" x 2" opening - Black

**5/16" SLOTS**

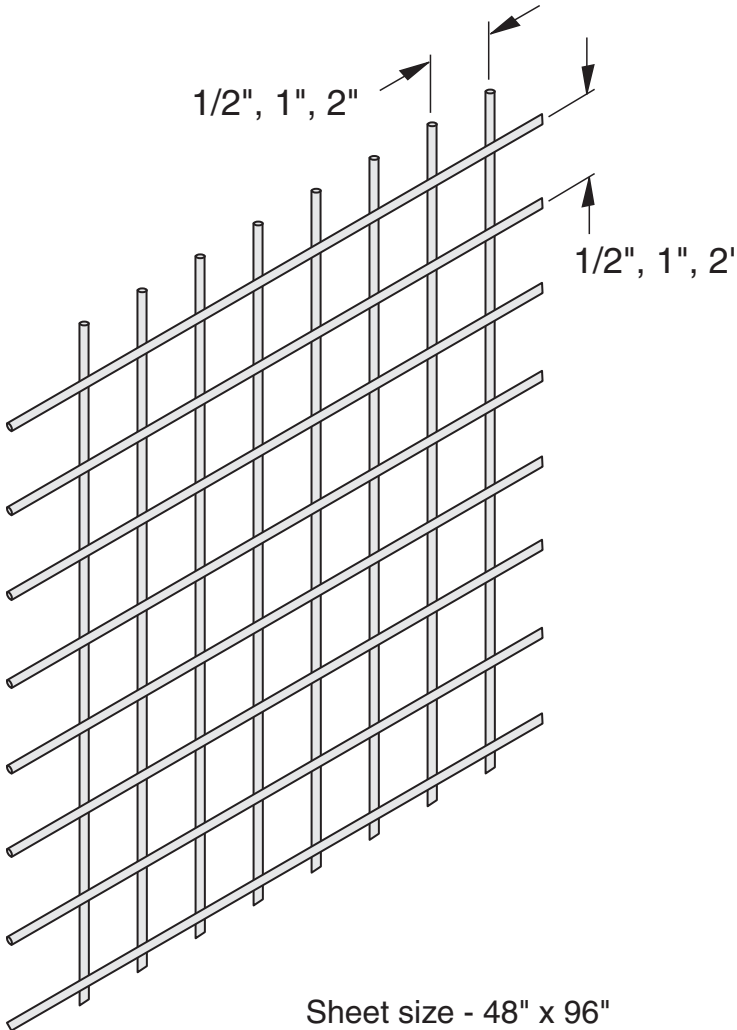

Material - PVC Coated Steel  
 Yellow or Black  
 Other colors/finishes available upon request

Use with EB-38-1 or EB-38-1/2

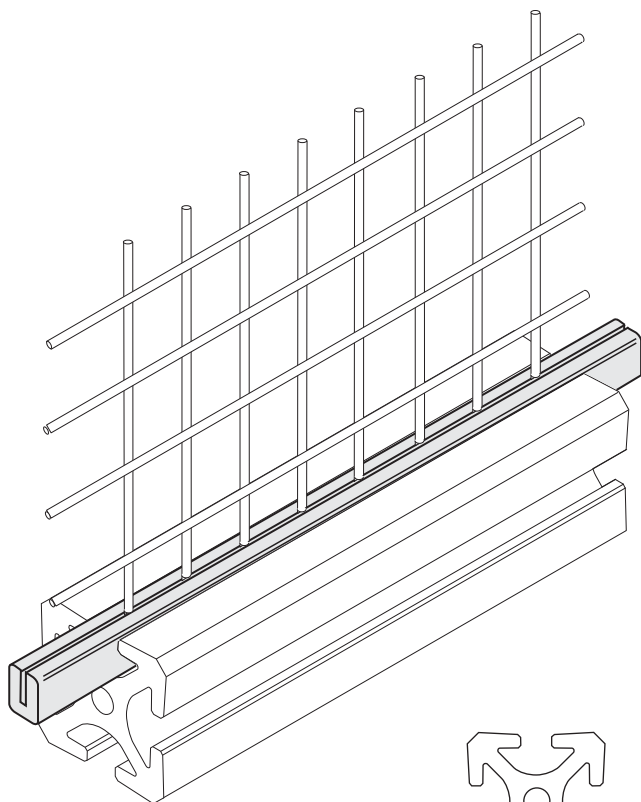
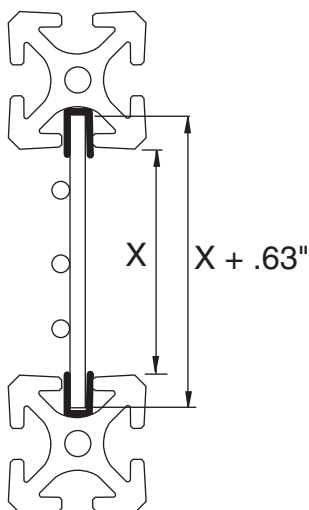
**EB-38G****5/16" SLOTS**

To specify length required,  
order EB-38G, length in feet.

Note: Snug fit - eliminates rattles

Cut wire  
mesh to  $X +$   
.63"

Material - Black Rubber



# Wire Mesh Bracket



**EB-39A**  
**EB-39B**

All Hardware  
Included

5/16" SLOTS

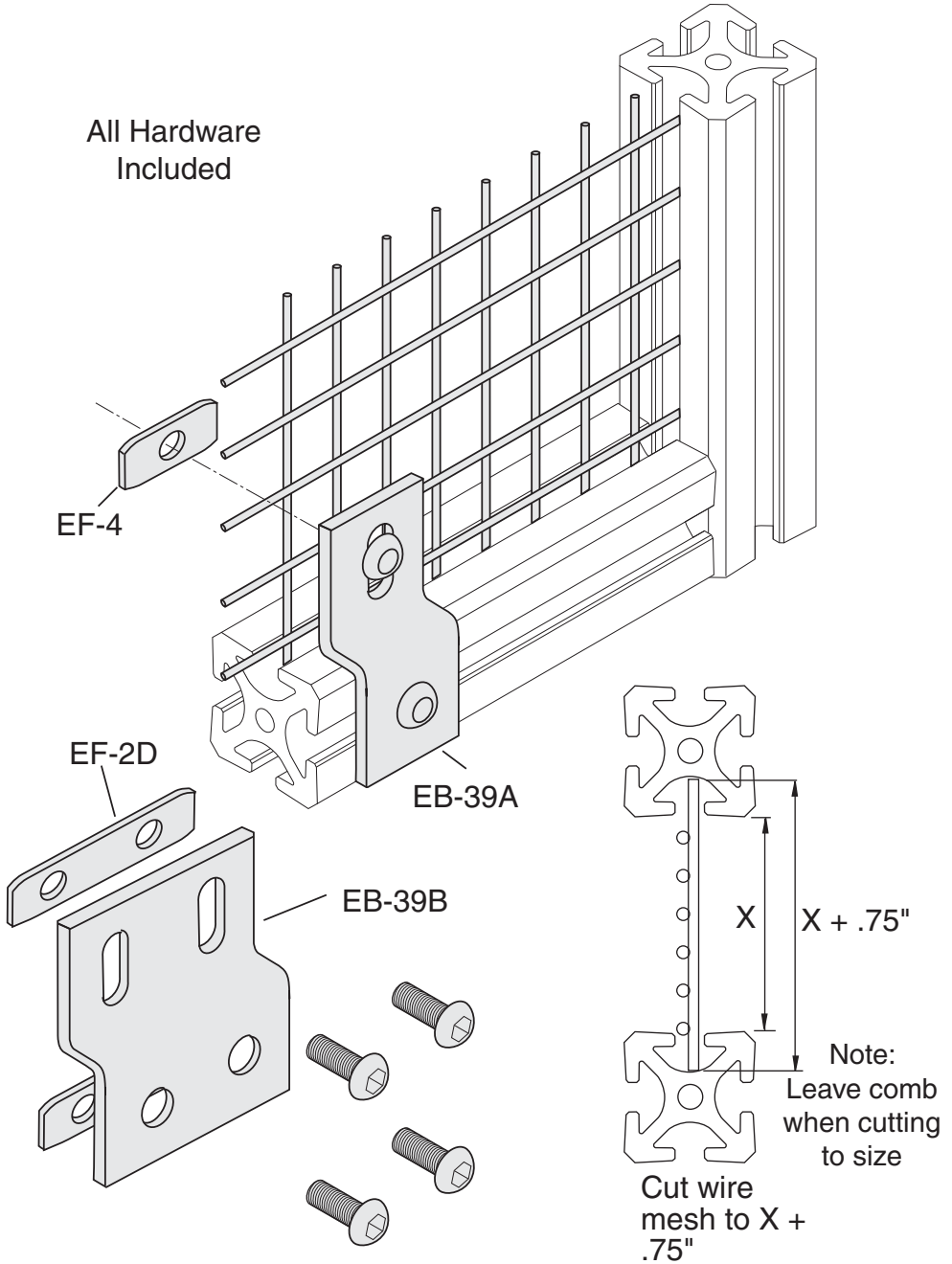

Material - Steel  
Finish - Black Powder Coat

<b>Black Powder Coat</b>	<b>EB-49B</b>
<b>Yellow Powder Coat</b>	<b>EB-49Y</b>

Note: to be used with  
EB-38-1 and EB-38-1Y  
screen only

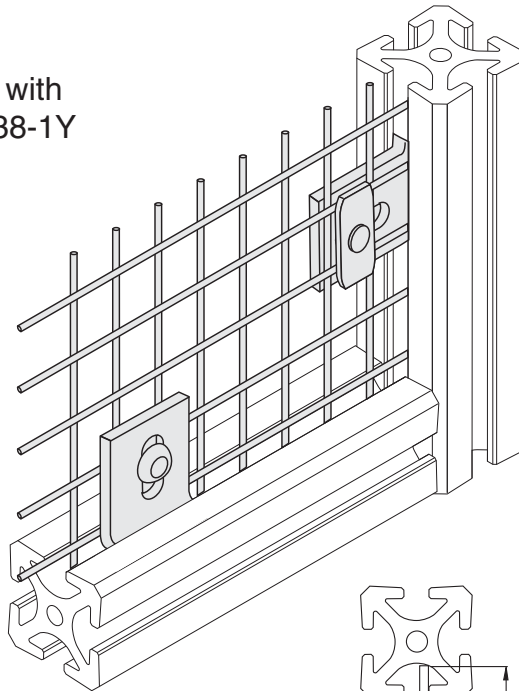

**5/16" SLOTS**

**Hardware Included**

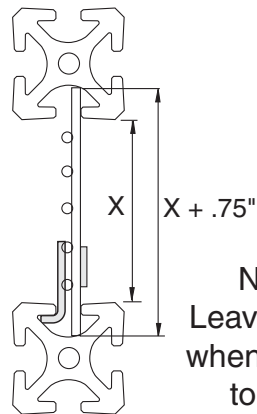
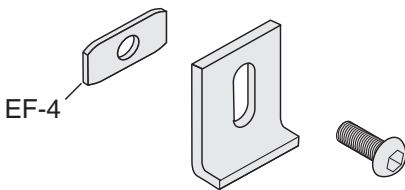

Note:  
Leave comb  
when cutting  
to size

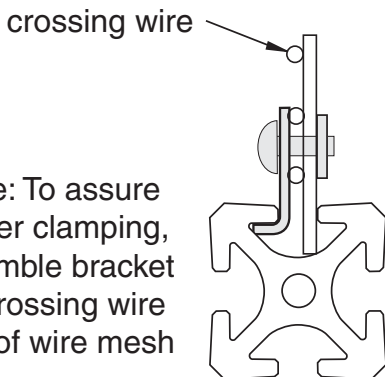

Cut wire  
mesh to  $X + .75"$

Note: To assure  
proper clamping,  
assemble bracket  
on crossing wire  
side of wire mesh

**Material - Powder Coated Steel**

**EB-63**

5/16" SLOTS

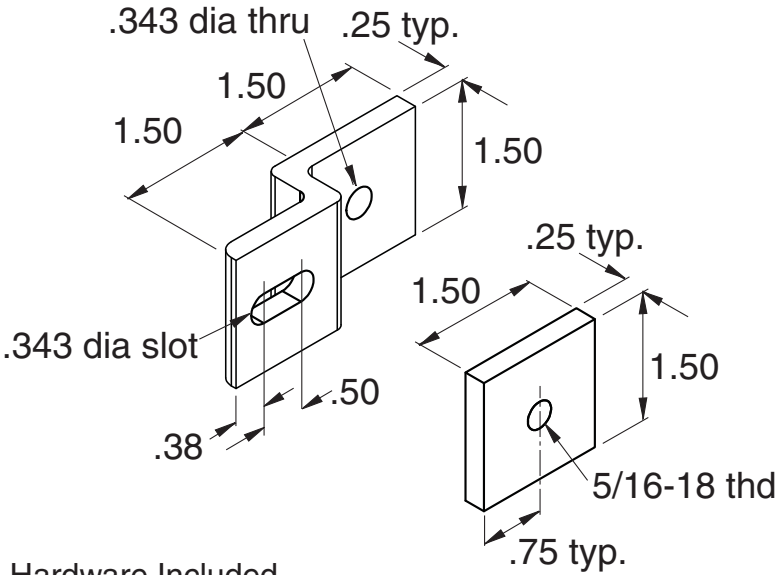

Hardware Included

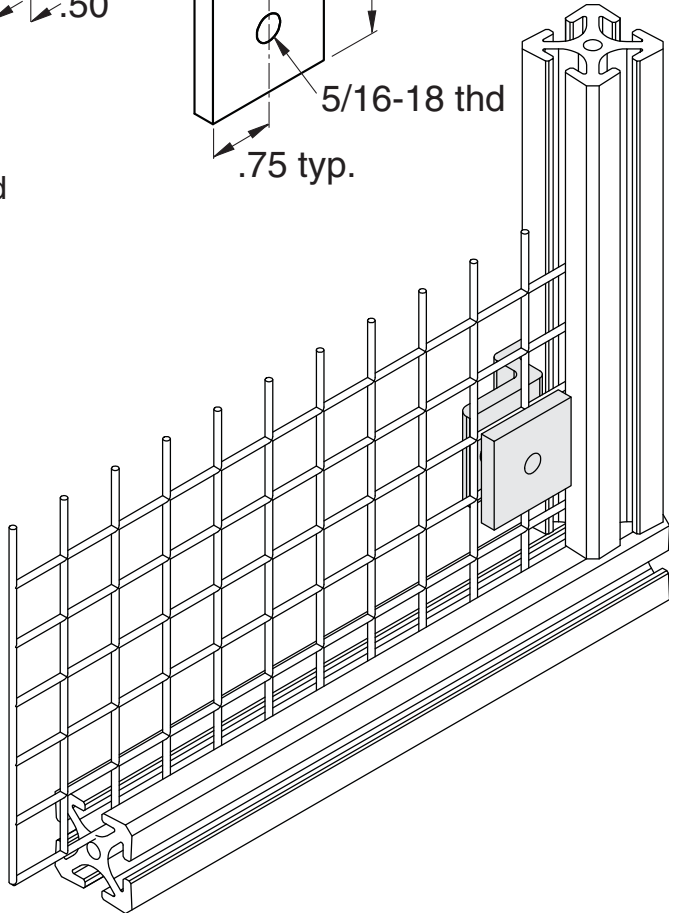

Material - Aluminum  
Finish - Clear Anodize

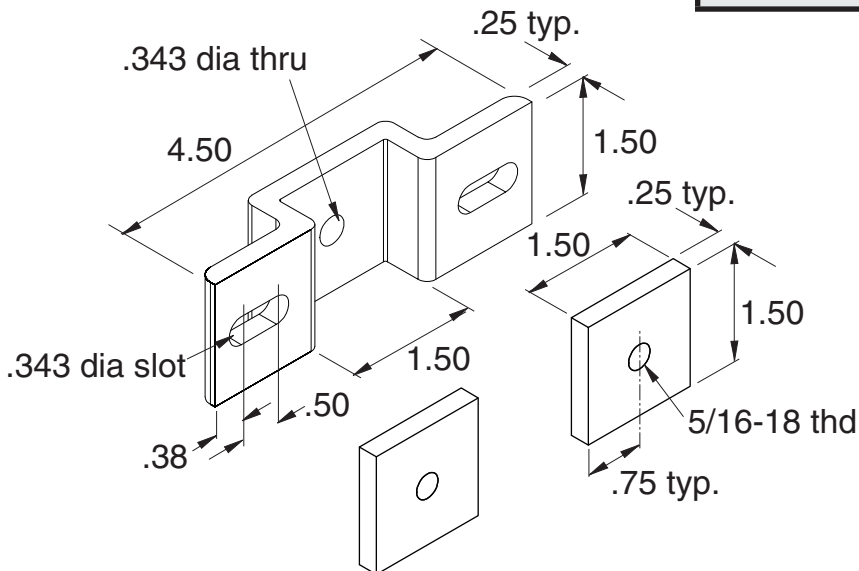

**5/16" SLOTS**

**Hardware Included**

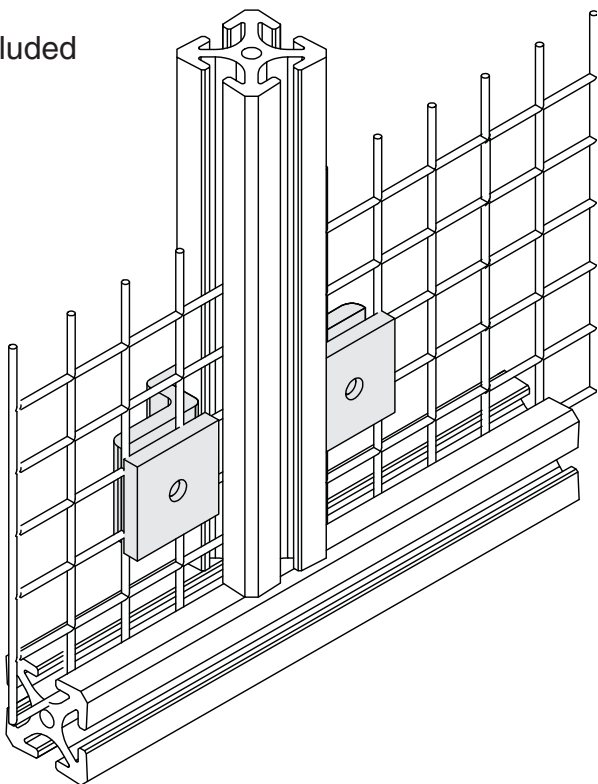

**Material - Aluminum**  
**Finish - Clear Anodize**

**EB-96**

5/16" SLOTS

Note: Use with EB-38-2

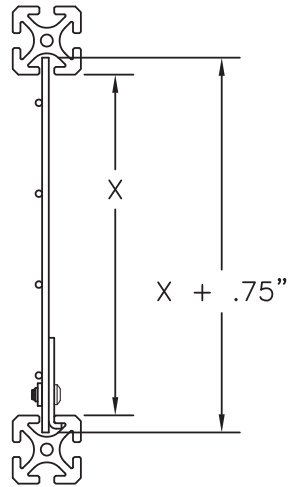
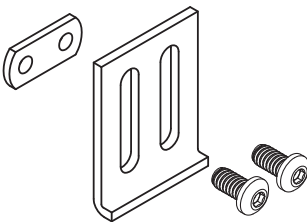
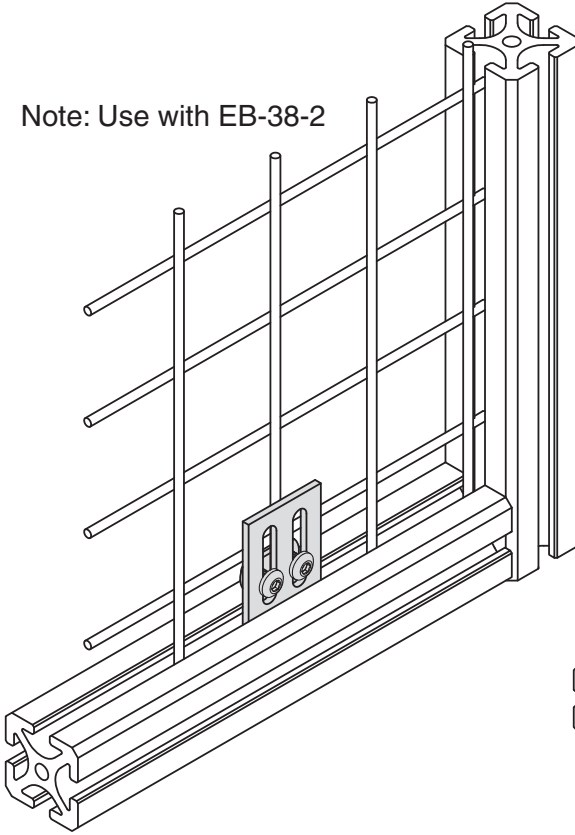

Cut Wire Mesh  
to  $X + .75$ "  
Note: Leave Comb  
when cutting to size

Hardware Included

Material - Steel  
Finish - Black Powder Coat

Stocked in 48" x 96" sheets  
Sold by the square foot.

- EB-160** Polycarb 1/4" Clear Panel
- EB-161** Polycarb 1/4" Bronze Panel
- EB-162** Polycarb 1/4" Black Panel
- EB-165** Polycarb 3/16" Clear Panel
- EB-166** Polycarb 3/16" Bronze Panel
- EB-170** Acrylic 1/4" Clear Panel
- EB-171** Acrylic 1/4" Bronze Panel
- EB-172** Acrylic 1/4" Black Panel
- EB-175** Acrylic 3/16" Clear Panel
- EB-176** Acrylic 3/16" Bronze Panel
- EB-177** Acrylic 3/16" Black Panel
- EB-180** ABS-Haircell 1/4" Black Panel
- EB-181** ABS-Haircell 3/16" Black Panel
- EB-185** Expanded PVC 6mm Yellow Panel
- EB-186** Expanded PVC 3mm Yellow Panel
- EB-187** Expanded PVC 6mm Grey Panel
- EB-188** Expanded PVC 3mm Grey Panel
- EB-189** Expanded PVC 6mm Blue Panel
- EB-190** Expanded PVC 3mm Blue Panel
- EB-191** Expanded PVC 6mm Red Panel
- EB-192** Expanded PVC 3mm Red Panel
- EB-193** Expanded PVC 6mm Black Panel
- EB-194** Expanded PVC 3mm Black Panel
- EB-195** Expanded PVC 6mm White Panel
- EB-196** Expanded PVC 3mm White Panel
- EB-197** Polycarb 1/4" Clear Scratch-resistant Panel
- EB-198** Polycarb 3/16" Clear Scratch-resistant Panel

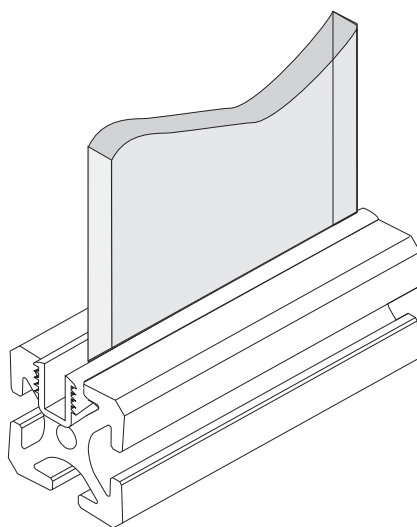
**5/16" SLOTS**

Cut to size panels can be furnished on request.

For panels with both sides less than or equal to 48",  
order EM-4S Cutting Service.

For panels with any side larger than 48",  
order EM-4L cutting service.

# 1/4 Turn Panel Bracket



<b>EB-88A</b>	<b>.235 Thick Panel</b>
<b>EB-88B</b>	<b>.220 Thick Panel</b>
<b>EB-88C</b>	<b>.170 Thick Panel</b>

**5/16" SLOTS**

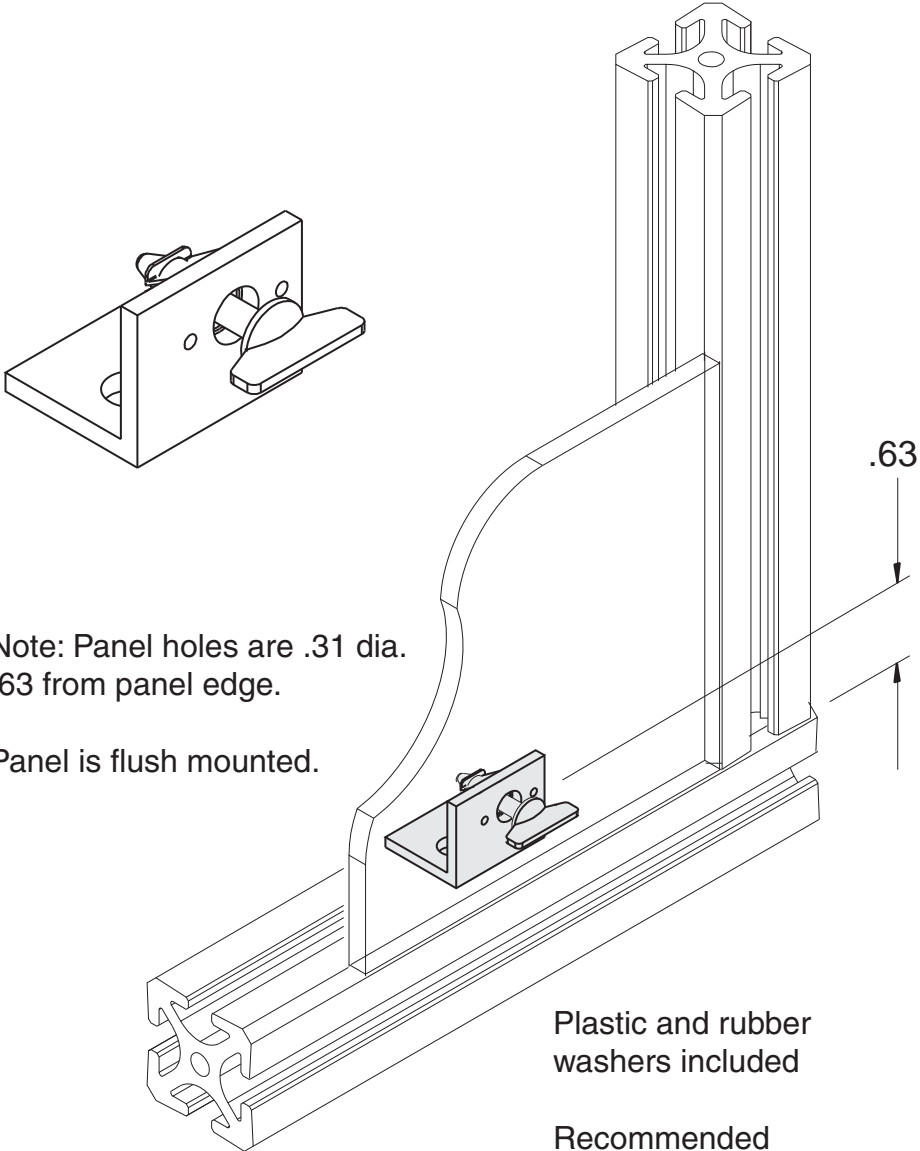

Note: Panel holes are .31 dia.  
.63 from panel edge.

Panel is flush mounted.

Plastic and rubber  
washers included

- Recommended  
Hardware
- (1) EF-12-.50 BHCS
  - (1) EF-1 T-nut or
  - (1) EF-2 T-nut

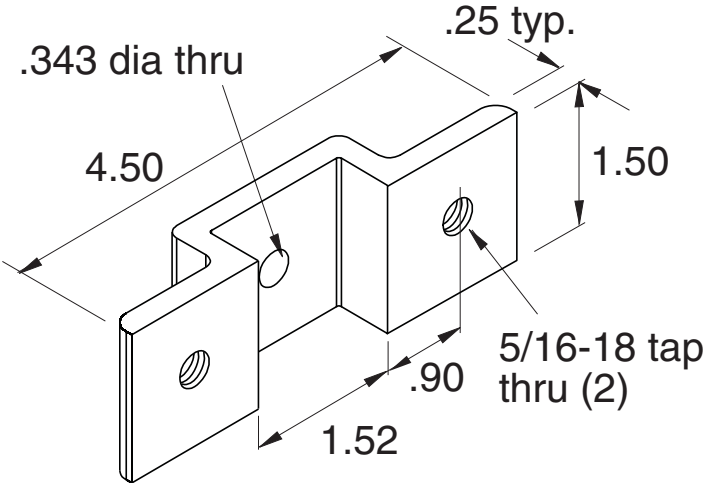

**5/16" SLOTS**

Hardware Included

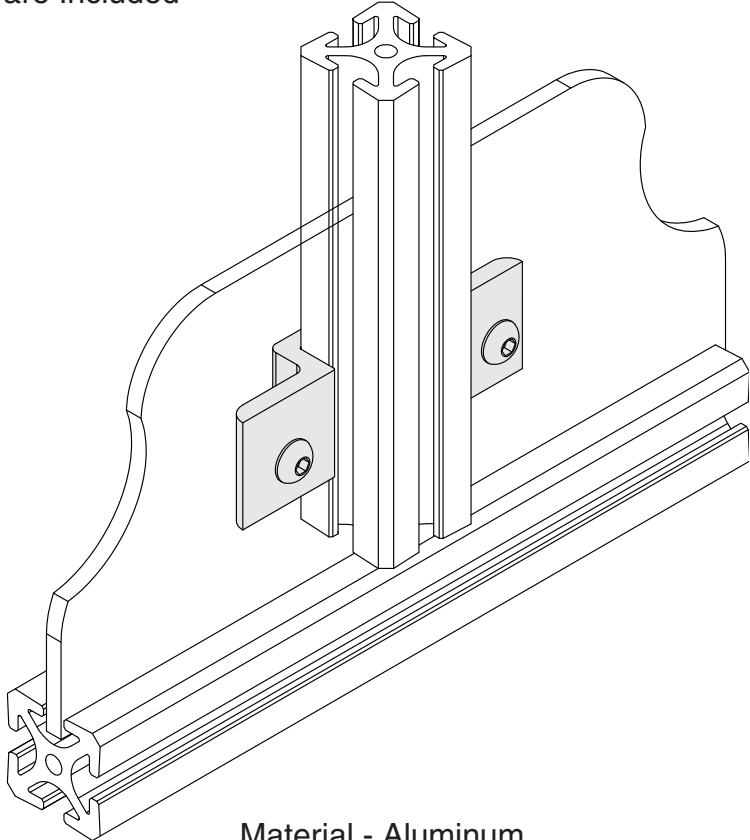

**Material - Aluminum  
Finish - Clear Anodize**



**EB-62**

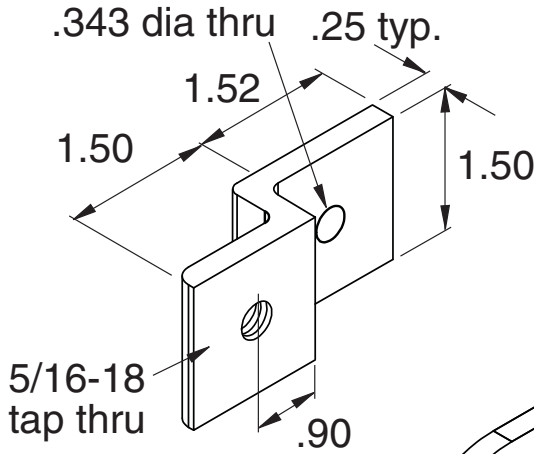

5/16" SLOTS

Hardware Included

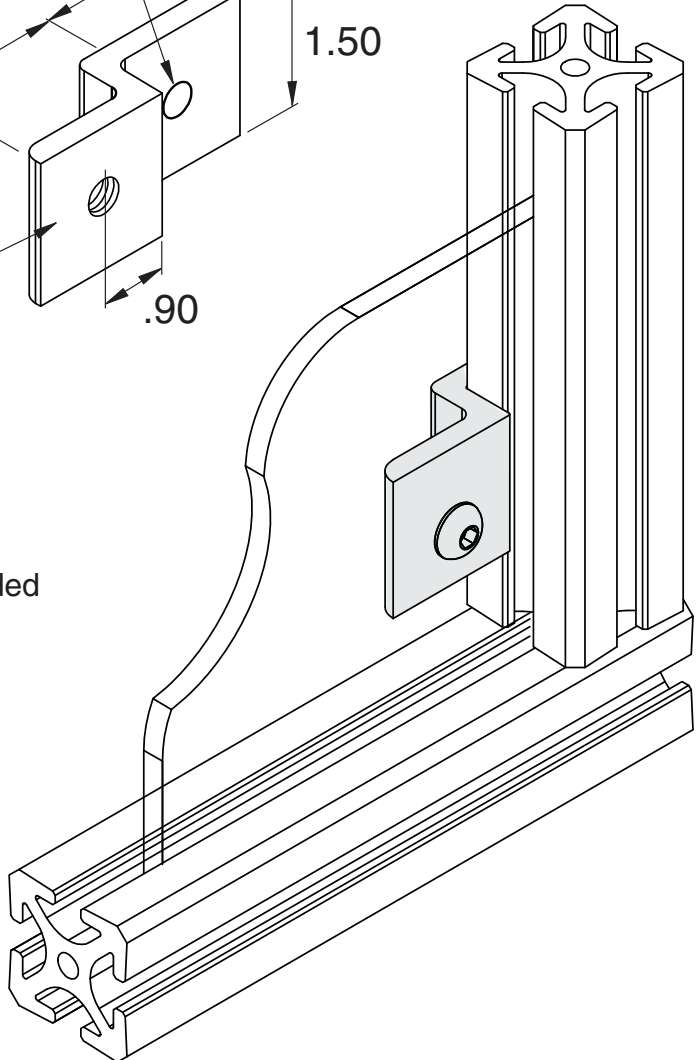

Material - Aluminum  
Finish - Clear Anodize

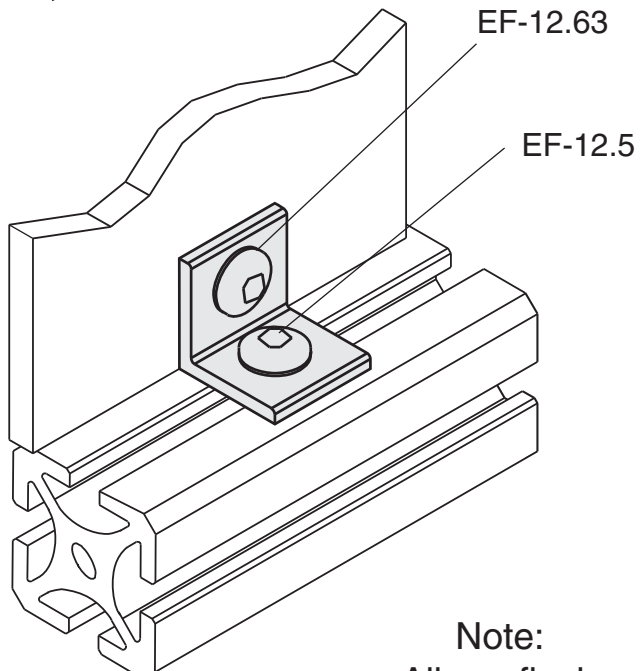
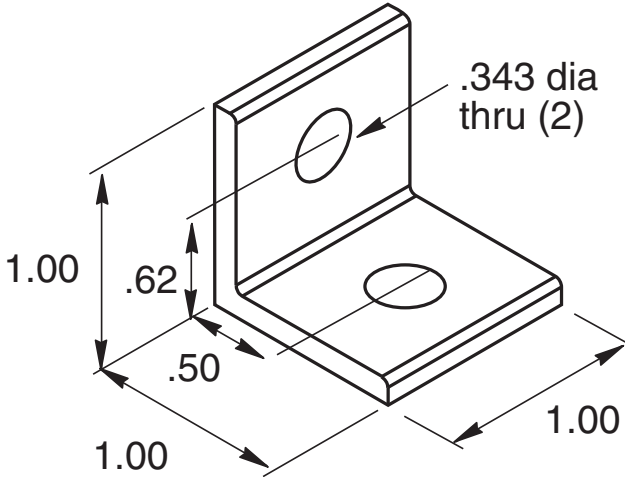

**5/16" SLOTS**

**Recommended Hardware**

- (1) EF-12-.50 BHCS
- (1) EF-12-.63 BHCS
- (2) EF-2 T-nut

**Note:**  
Allows flush  
mount of panel

**Material - Aluminum  
Finish - Clear Anodize**

# Panel Mounting Angle



**EB-80**

5/16" SLOTS

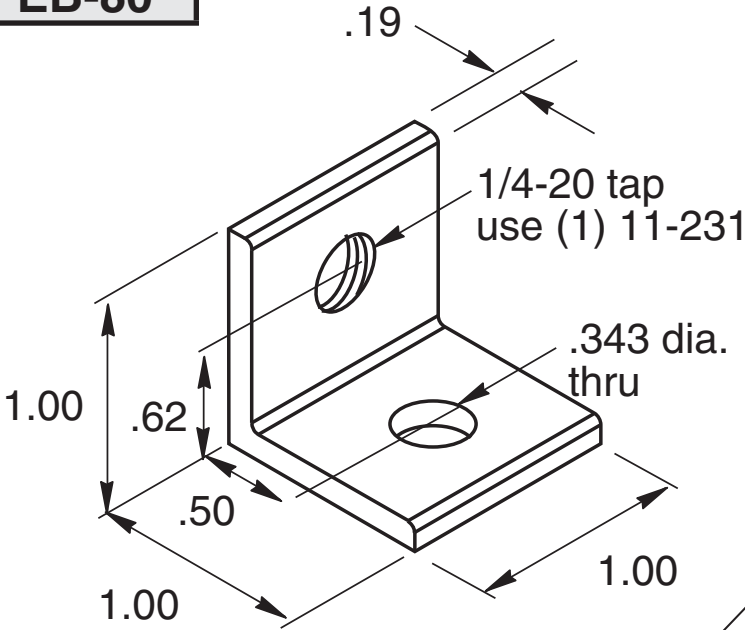

Note:  
Allows flush  
mount of panel

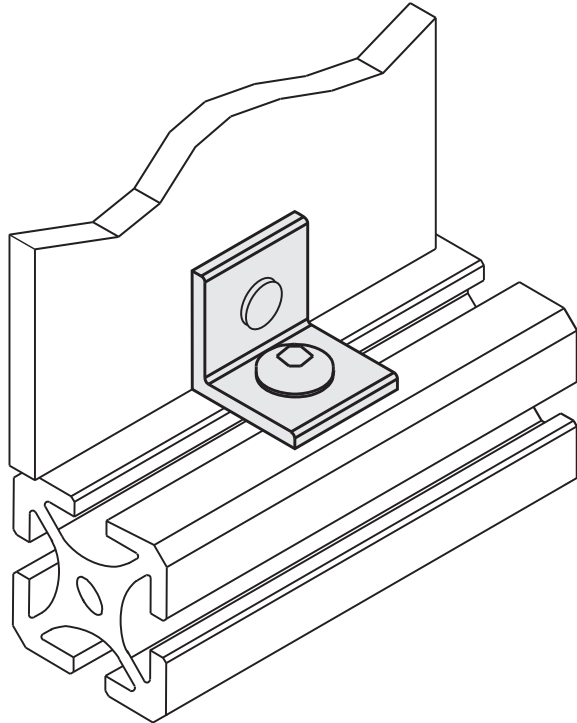

- Recommended Hardware
- (1) 11-231 BHCS
  - (1) EF-12-.63 BHCS
  - (1) EF-2 T-nut

Material - Aluminum  
Finish - Clear Anodize

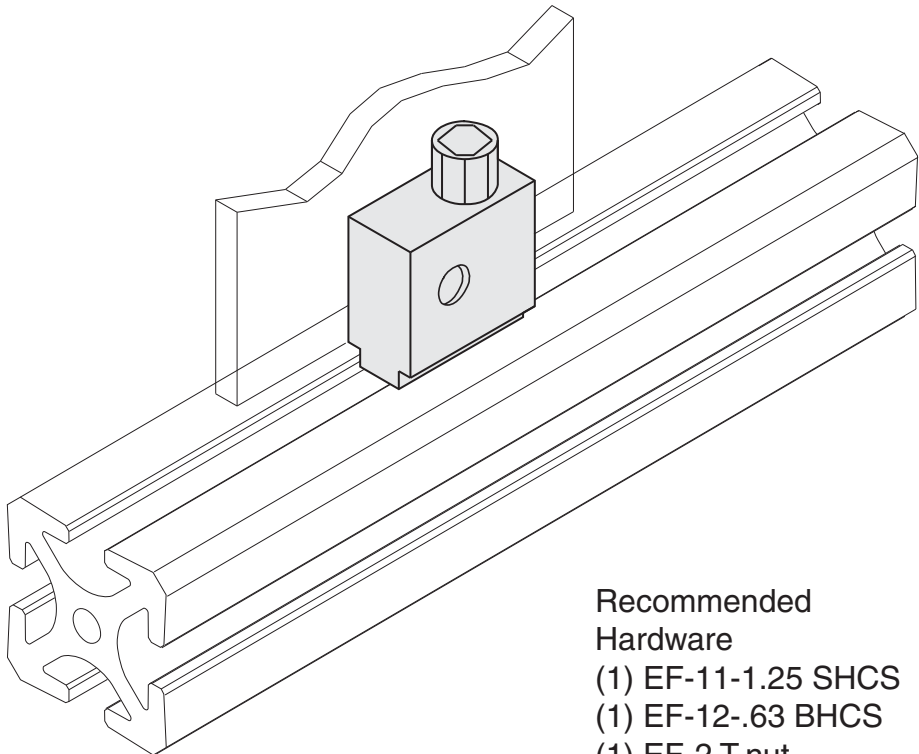
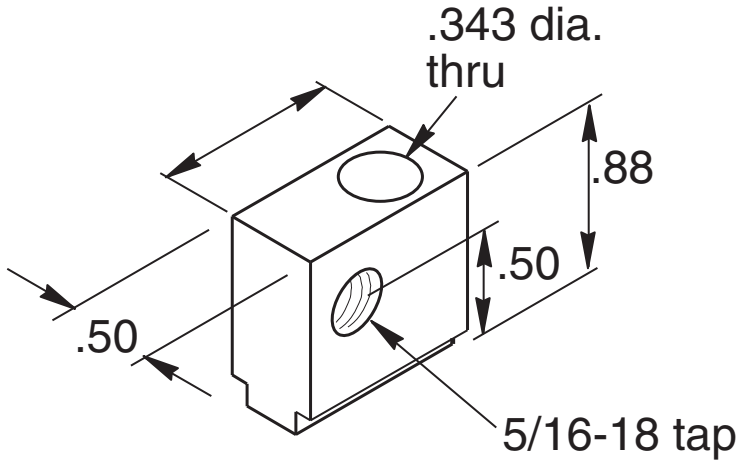

**Recommended  
Hardware**

- (1) EF-11-1.25 SHCS
- (1) EF-12-.63 BHCS
- (1) EF-2 T-nut

**Material - Aluminum  
Finish - Clear Anodize**

**EF-25B**

5/16" SLOTS

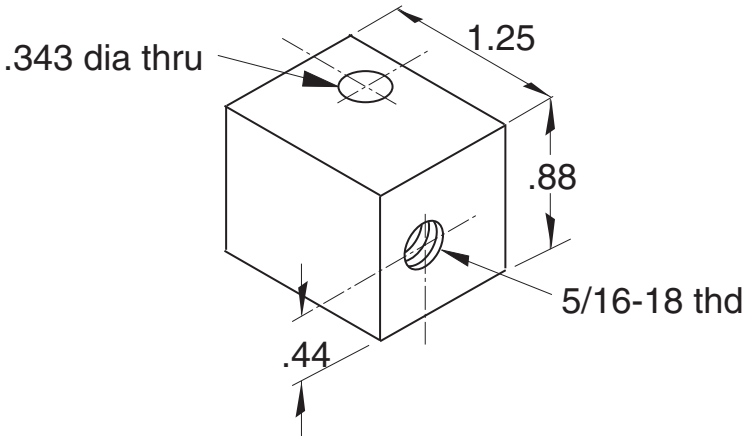

Flush surface  
with 1/4"  
panels

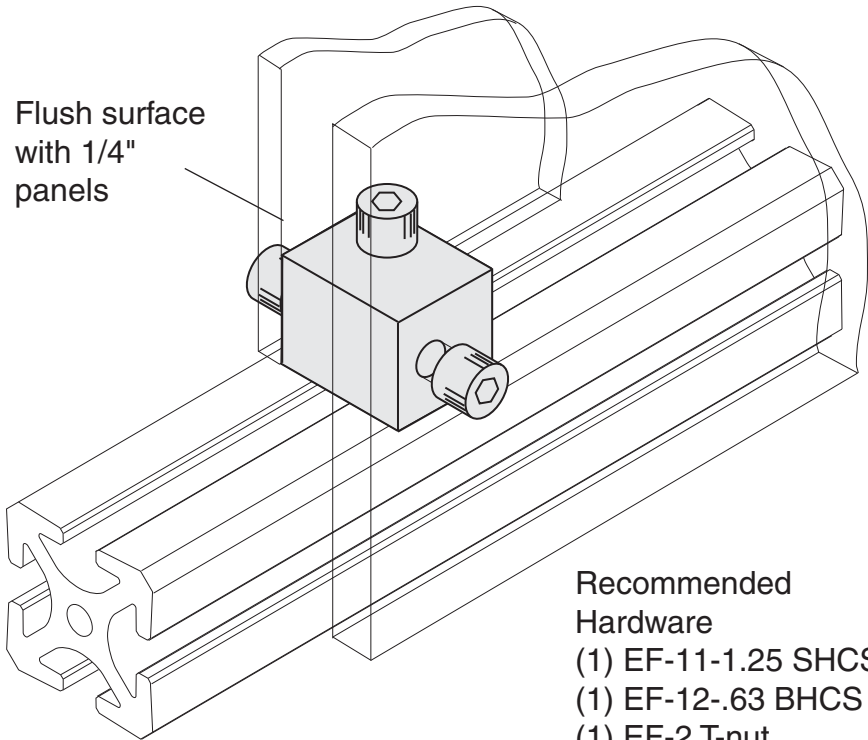

- Recommended  
Hardware
- (1) EF-11-1.25 SHCS
  - (1) EF-12-.63 BHCS
  - (1) EF-2 T-nut

Material - Aluminum  
Finish - Clear Anodize

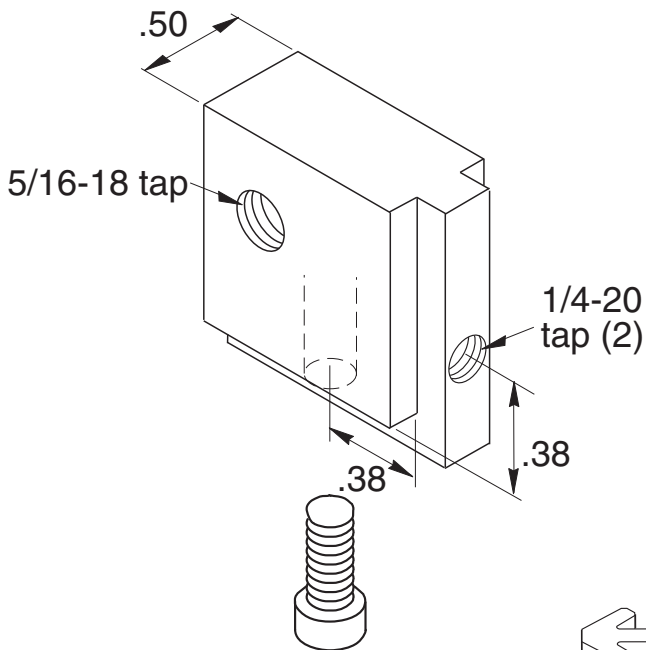

**5/16" SLOTS**

Recommended  
Hardware  
(2) 11-225 SHCS  
(1) EF-12-.63 BHCS

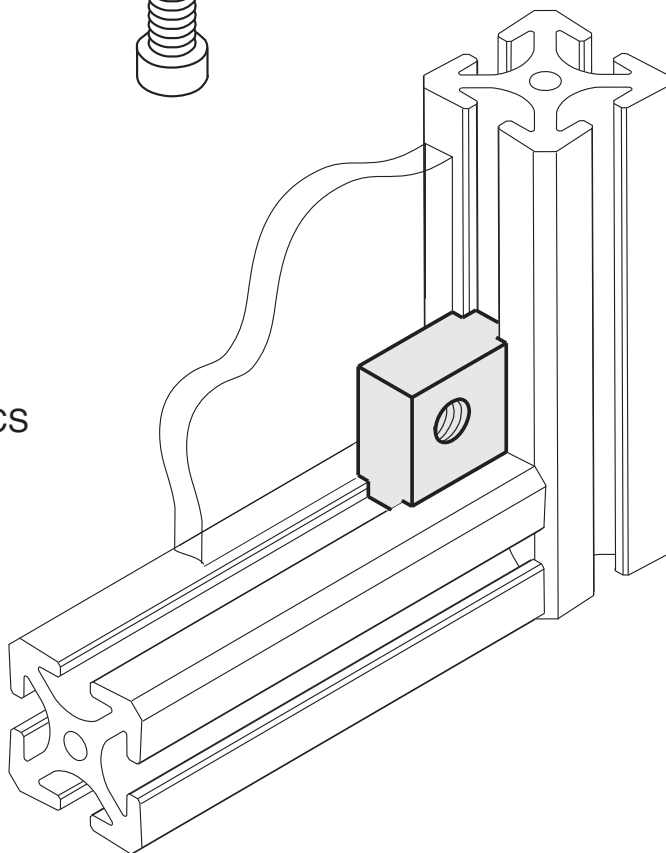

**Material - Aluminum  
Finish - Clear Anodize**

**EB-40**

5/16" SLOTS

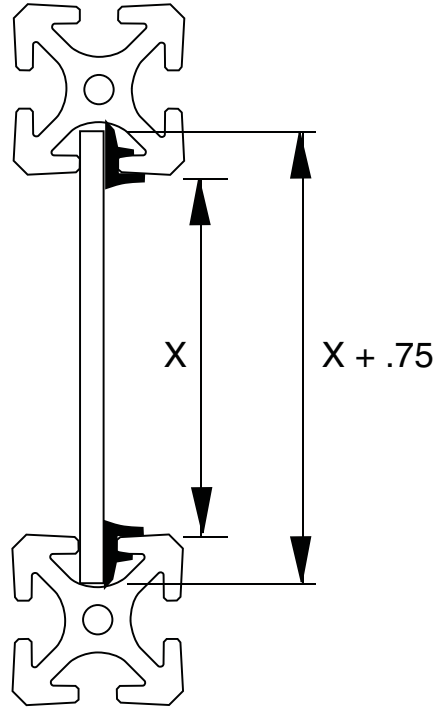
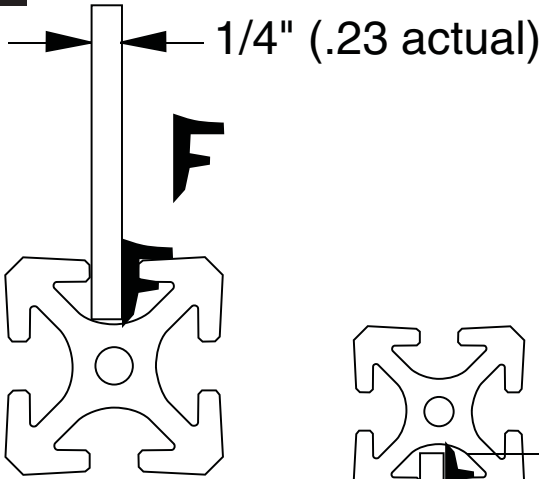

Cut panel to X + .75"

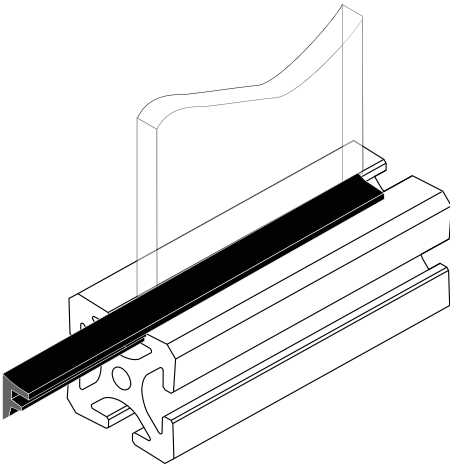

Note: insert gasket after panel is installed  
in 5/16" wide slot profiles

Material - Flexible PVC (Black)

Slip Fit	<b>EB-40A</b>
Interference Fit	<b>EB-40C</b>

 1/4" (.235 actual)

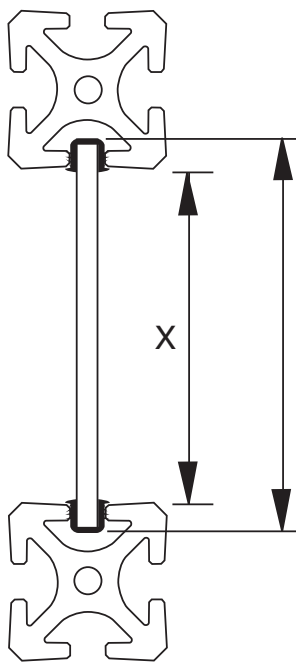
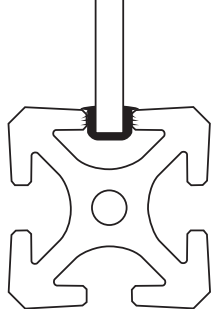

$X + .625'' = \text{EB-40A}$   
 $X + .625'' = \text{EB-40C}$

**5/16" SLOTS**

Cut panel to  
 $X + .625'' = \text{EB-40A}$   
 $X + .625'' = \text{EB-40C}$

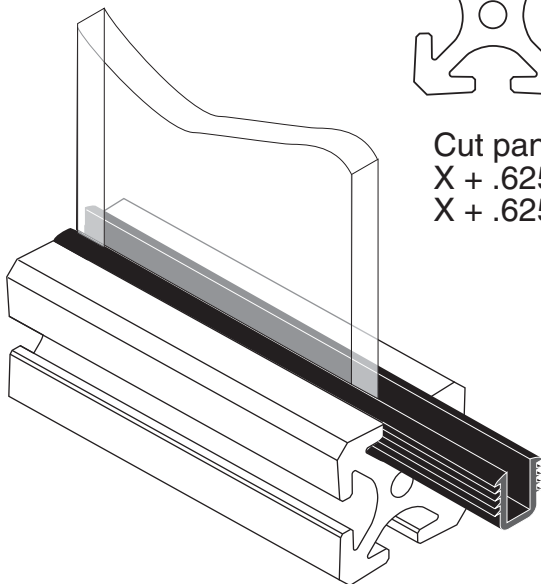

Note: For use on 5/16" wide profile slots.

**Material - Flexible PVC (Grey)**



**EB-40B**

5/16" SLOTS

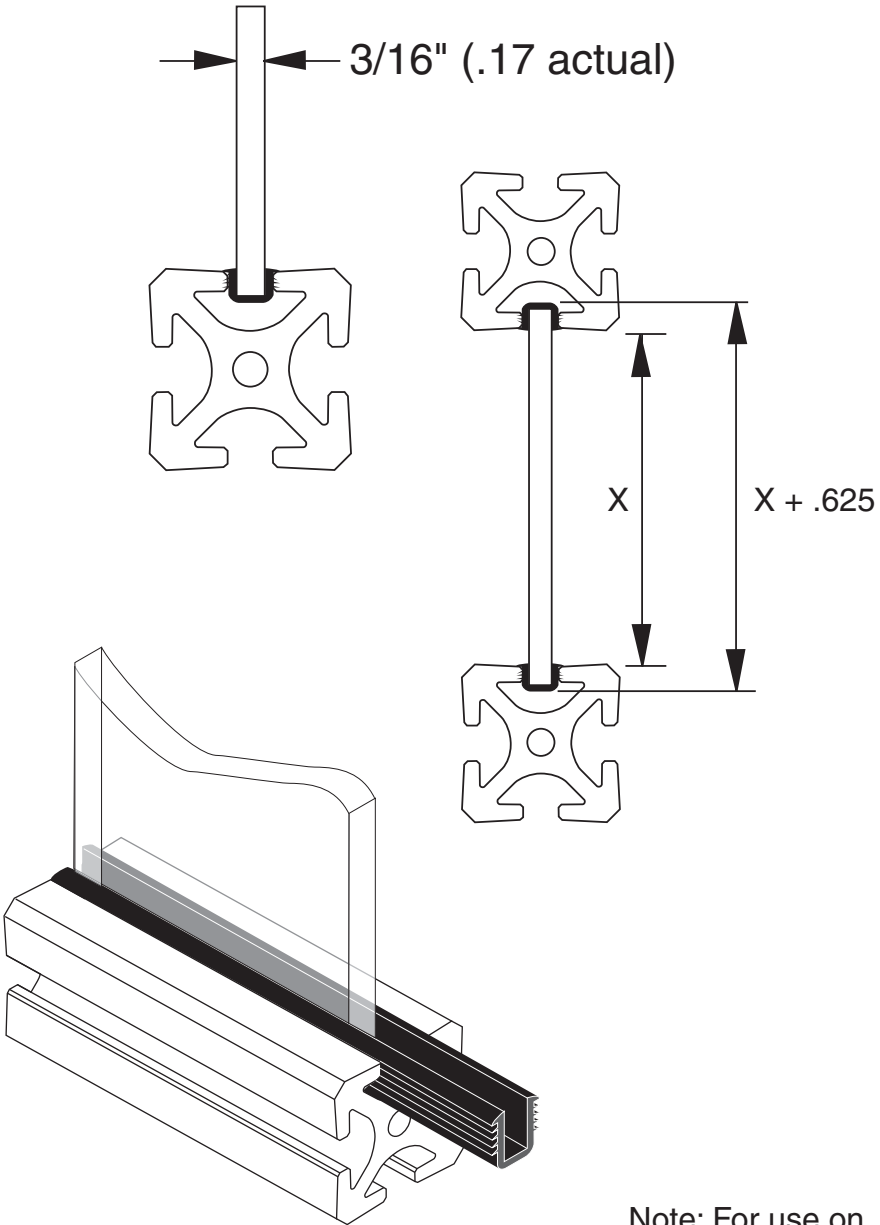

Note: For use on  
5/16" wide profile slots.

Material - Flexible PVC (Grey)

(12) gage to  
(16) gage panels

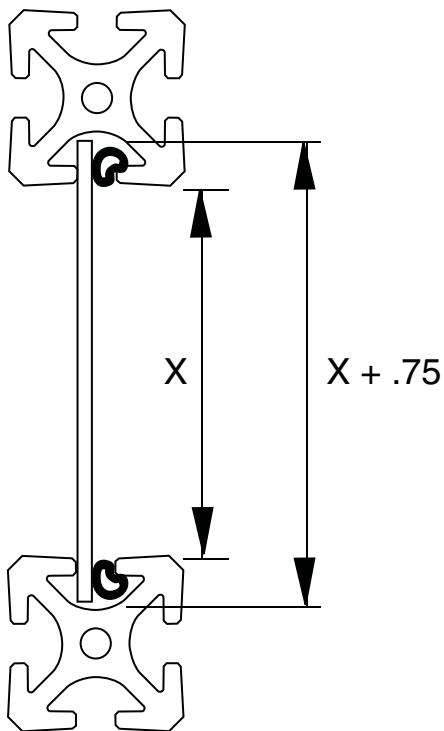
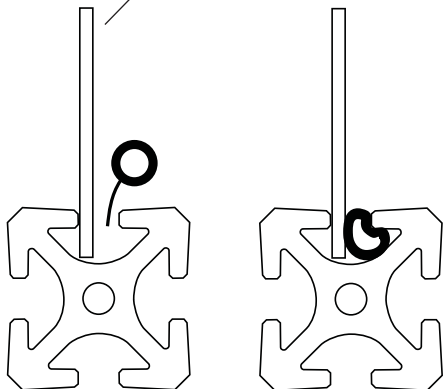

**5/16" SLOTS**

Cut panel to  $X + .75$ "

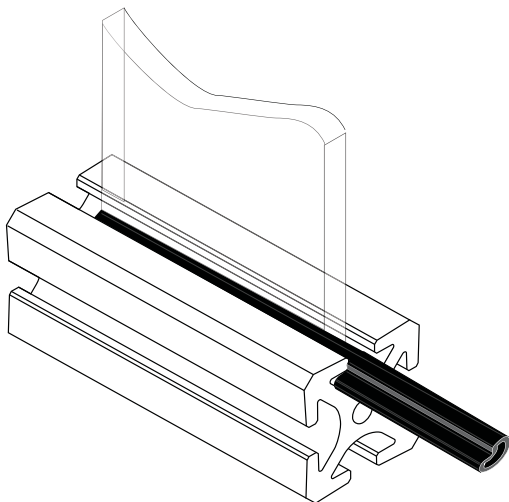

Material	Thickness
16 gage	.060
14 gage	.075
13 gage	.090
12 gage	.105

Material - Rubber (Black)

# Door Stop (Light Blocking)



**EX-56** (.385 lbs/ft)

5/16" SLOTS

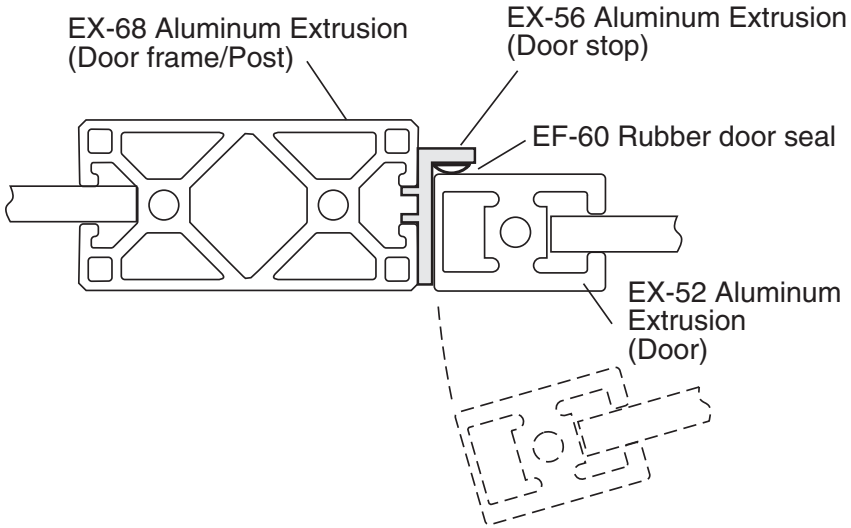
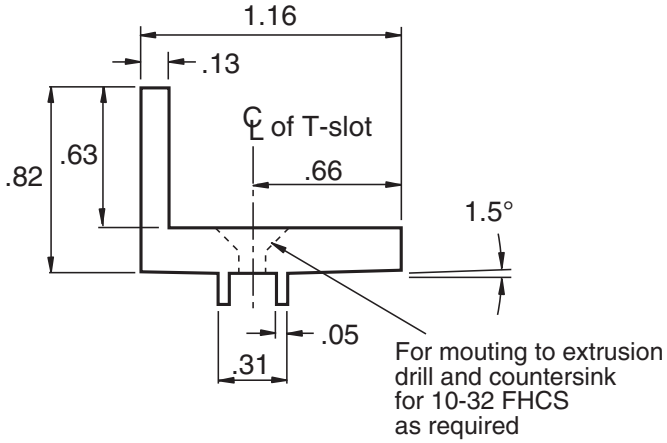

Standard size 96" and 192", sold by the inch

Material - Aluminum  
Finish - Clear Anodize

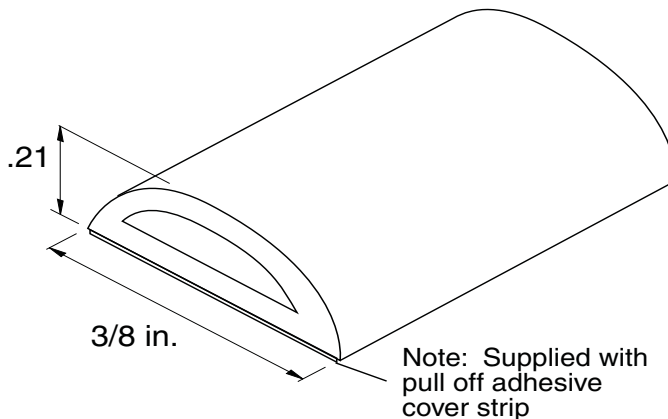

Sold by the foot

### Example: Door Frame Cross-Section

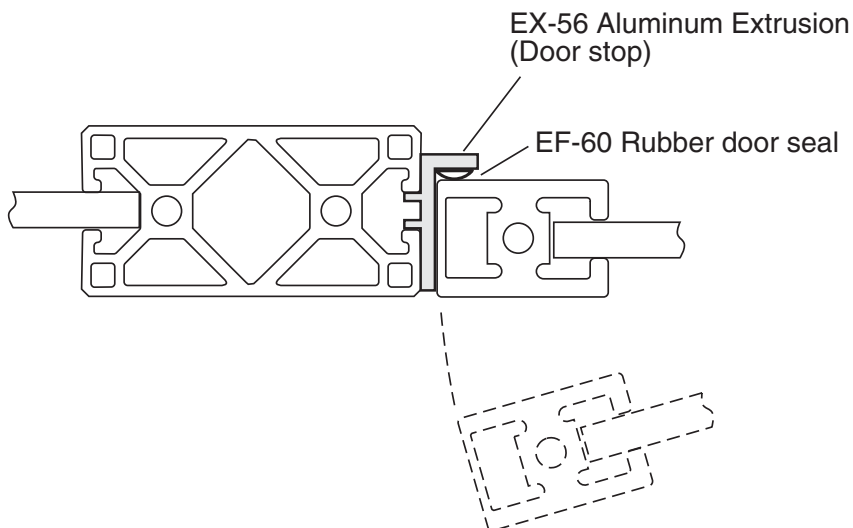

5/16" SLOTS

Door Slides (3 Tracks) 5/16" slots



<b>EF-17-3</b>	Upper Door Slide Track (1/4" panels)
<b>EF-18-3</b>	Lower Door Slide Track (1/4" panels)

5/16" SLOTS

**EF-17-3**

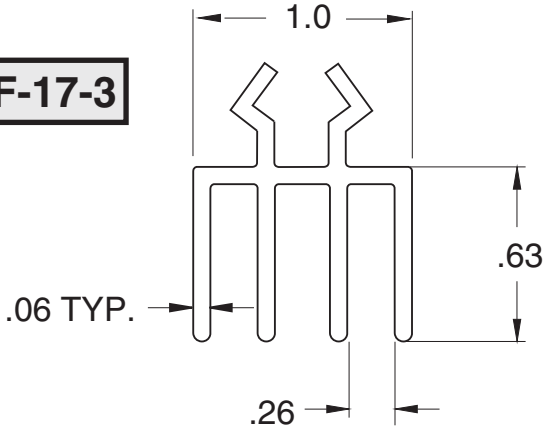

Material - Rigid PVC

Cut Panels to X - 1/2"

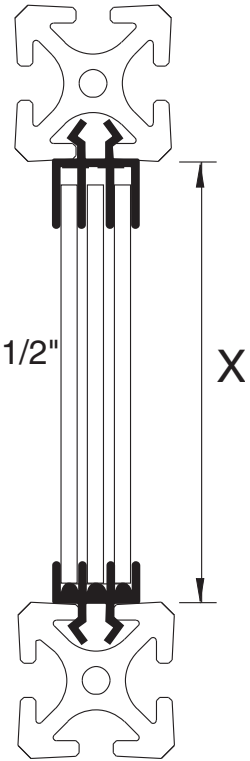

**EF-18-3**

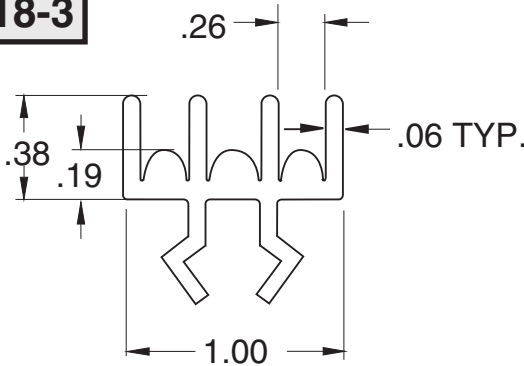

Material - Rigid PVC  
Sold in 6 ft. lengths

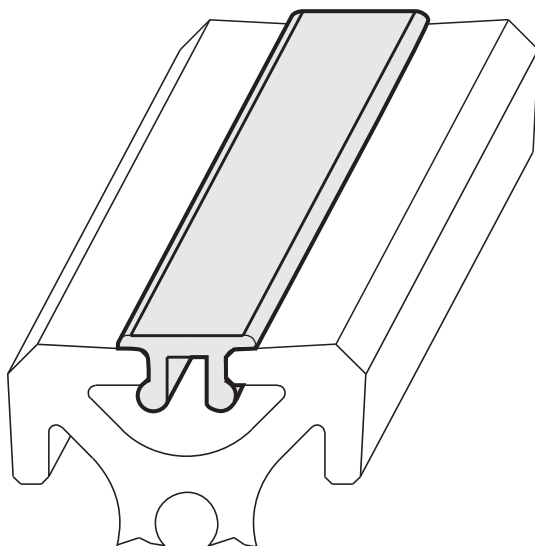

Sold in 6 ft. lengths

- EF-23G** Gray Rigid PVC
- EF-23B** Black Rigid PVC
- EF-23Y** Yellow Rigid PVC
- EF-23A** Clear Anodized Aluminum
- EF-23SO** Safety Orange Rigid PVC

# T-slot Cover or Panel Gasket



**EF-45**

**5/16" SLOTS**

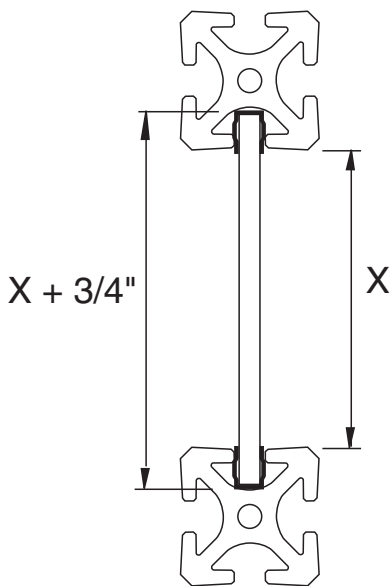
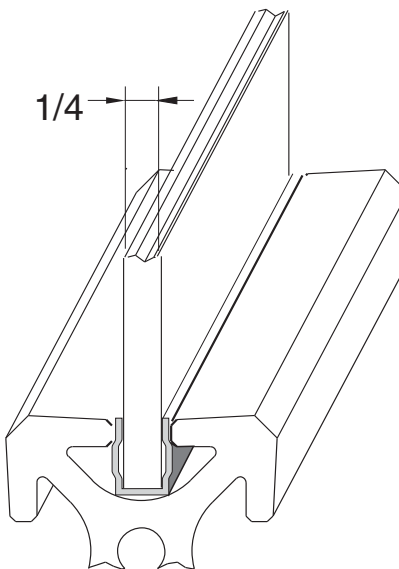
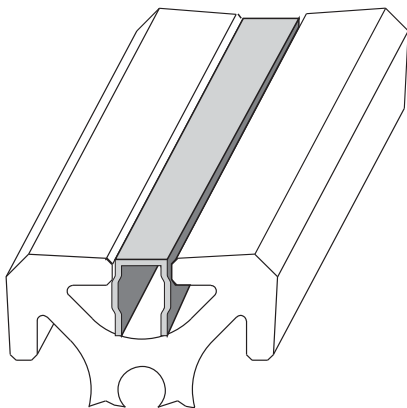

**Note:**  
T-slot cover rests below surface of extrusion - can pass under brackets.

**Cut panel to  $X + .75"$**

- EF-45B** Black
- EF-45Y** Yellow
- EF-45G** Grey
- EF-45SO** Safety Orange

Material - Rigid PVC

**Stiffener w/handle (.343 lb/ft)**

**EF-140**

**Stiffener w/o handle (.173 lb/ft)**

**EF-141**

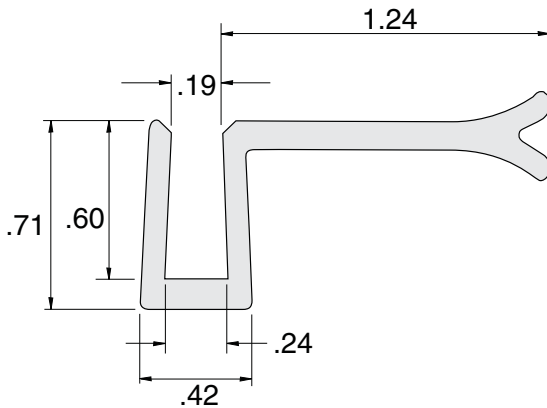

**EF-140**

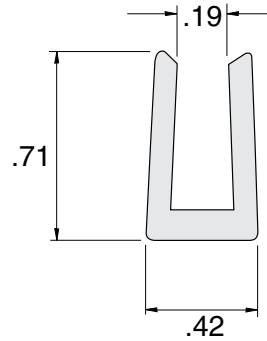

**EF-141**

**5/16" SLOTS**

Stocked in 144" lengths  
Sold by the inch

Note: Must use 1/4" Lexan for both EF-140 & EF-141

Note: can be used for swinging, slide and vertical lift doors.

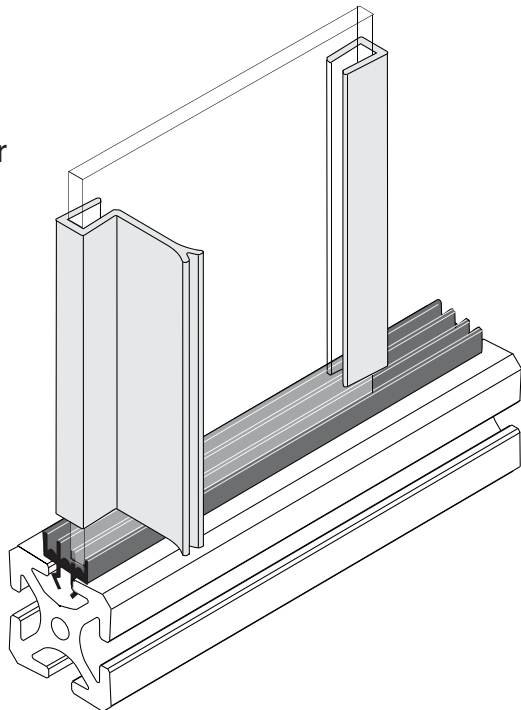

**Material - Aluminum  
Finish - Clear Anodize**



# Bi-fold Door Pad



**EF-110** use on 1.5 x 1.5 sq. extrusions with 5/16 wide slots

**5/16" SLOTS**

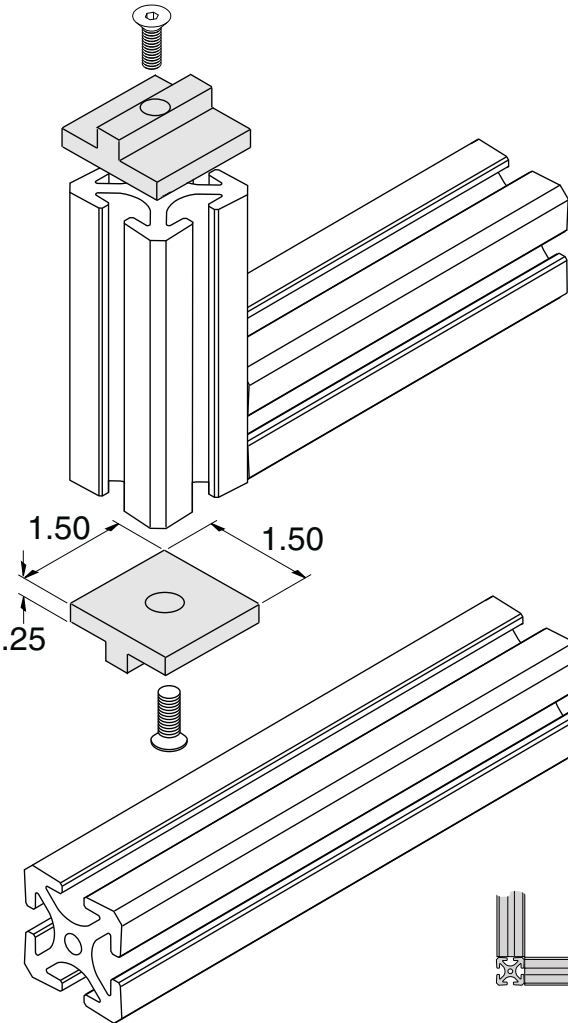

Hardware Included  
Material - DELRIN

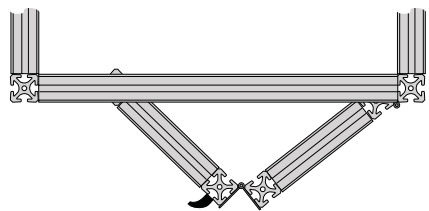

X = width of door opening  
Y = height of door opening

$$LX1 = \frac{(X-6.75)}{2} + .9375$$

$$LX2 = \frac{(X-6.75)}{2} - .9375$$

$$LY = Y-.5625$$

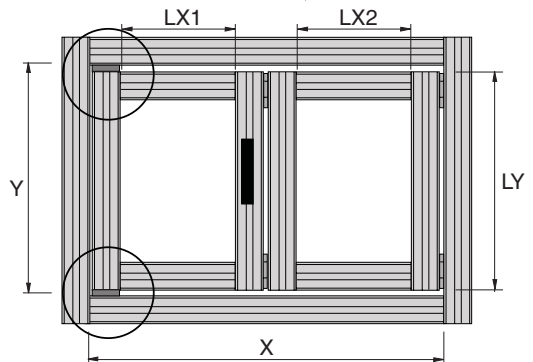

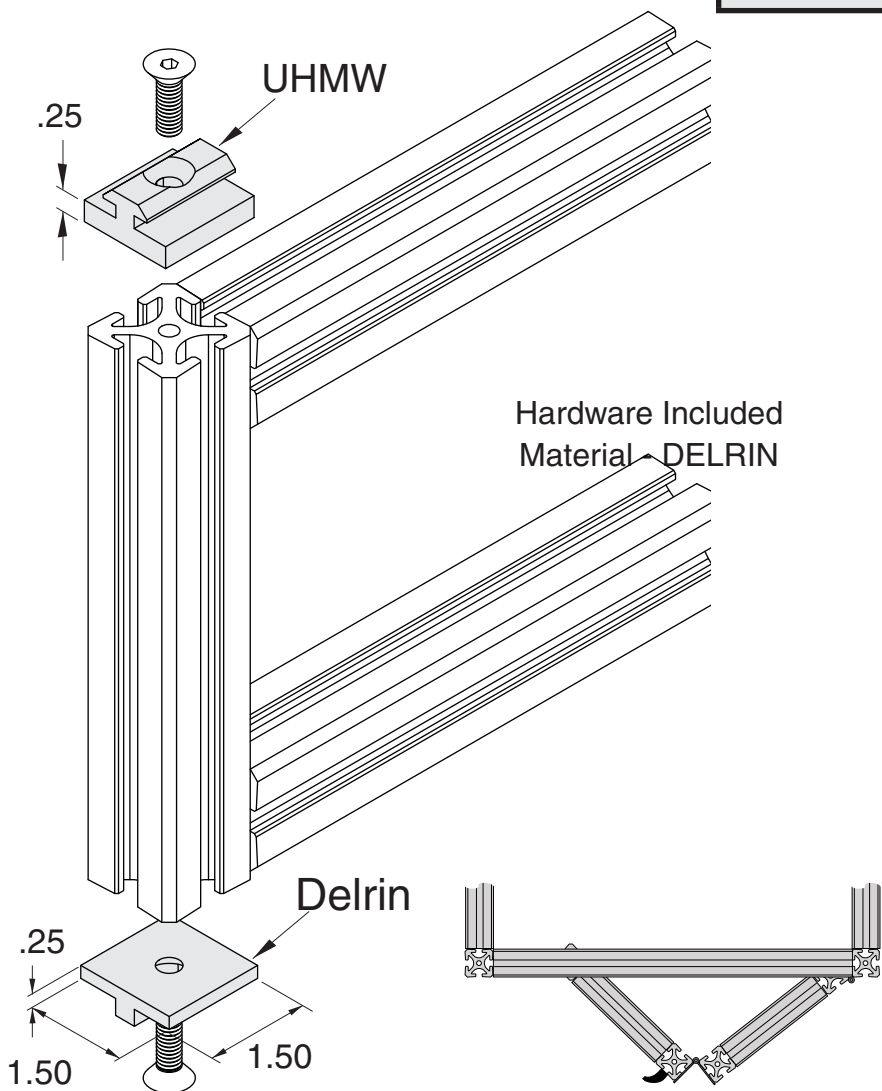

5/16" SLOTS

X = width of door opening  
Y = height of door opening

$$LX1 = \frac{(X-6.75)}{2} + .9375$$

$$LX2 = \frac{(X-6.75)}{2} - .9375$$

$$LY = Y - .5625$$

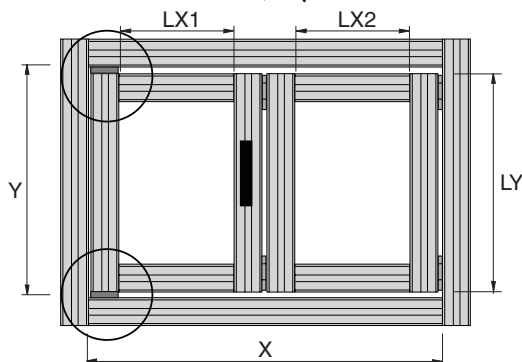

# Bi-fold Door Pad



**EF-115**

use on EX-52 and EX-54

5/16" SLOTS

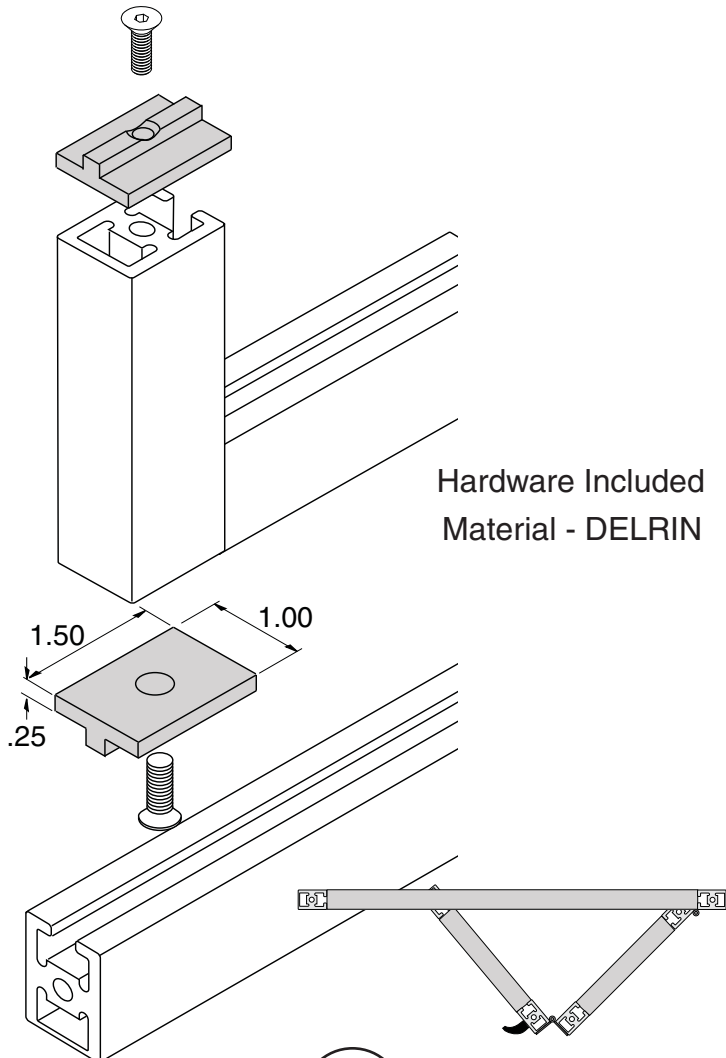

Hardware Included  
Material - DELRIN

X = width of door opening  
Y = height of door opening

$$LX1 = \frac{(X-6.75)}{2} + .9375$$

$$LX2 = \frac{(X-6.75)}{2} - .9375$$

$$LY = Y-.5625$$

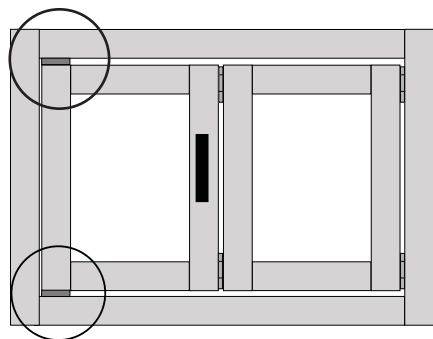

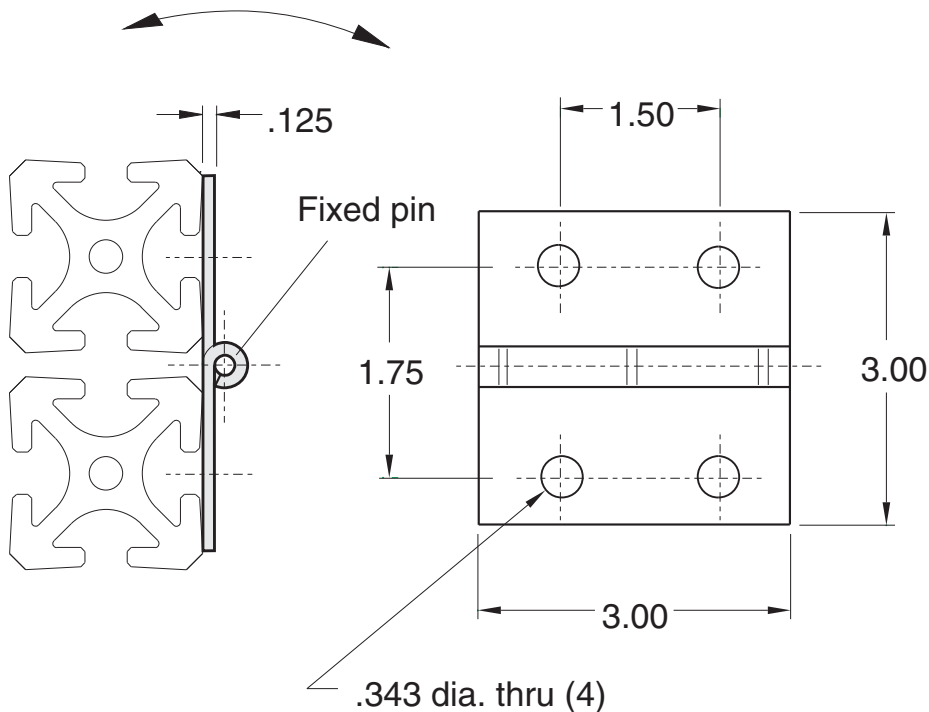

**5/16" SLOTS**

Hardware Included

Material - Aluminum  
Finish - Clear Anodize

**EF-20**

5/16" SLOTS

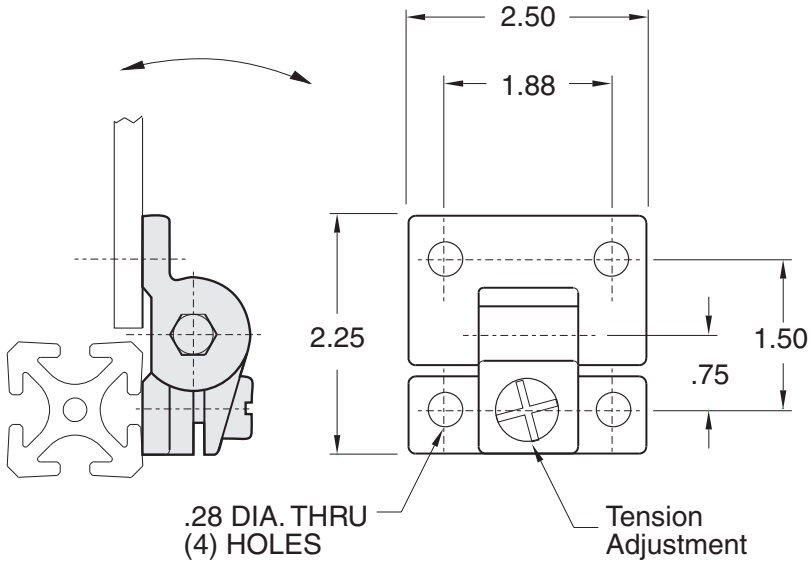

Hardware Included

Material - Plastic

**5/16" SLOTS**

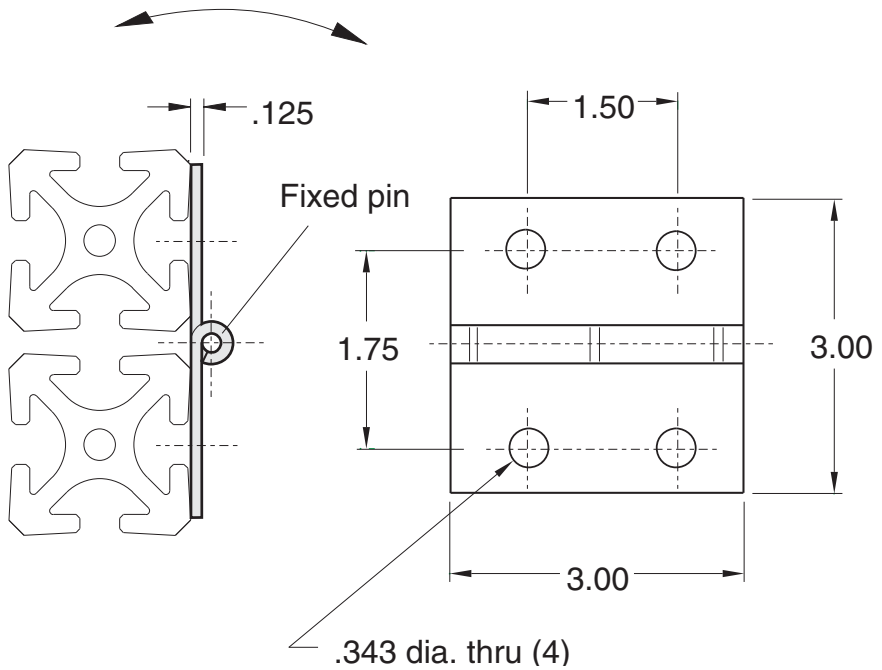

Hardware Included

Material - Steel  
Finish - Black Powder Coat

**EF-75**

5/16" SLOTS

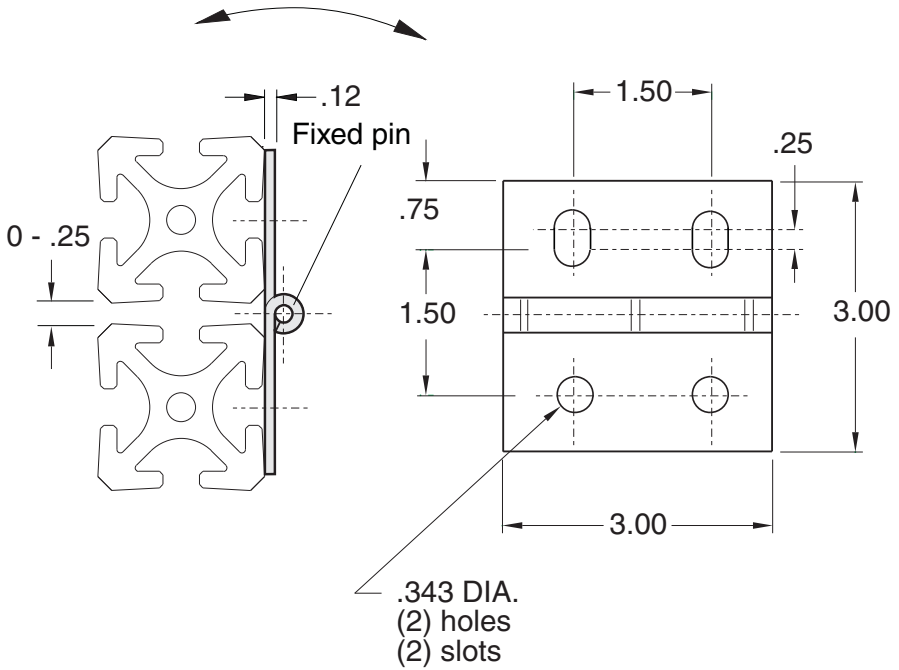

Hardware Included

Material - Steel  
Finish - Black Powder Coat

**EF-21LH**

**EF-21RH**

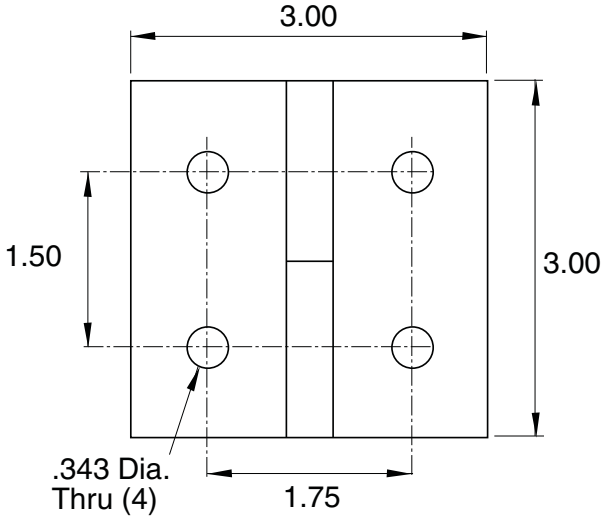

**5/16" SLOTS**

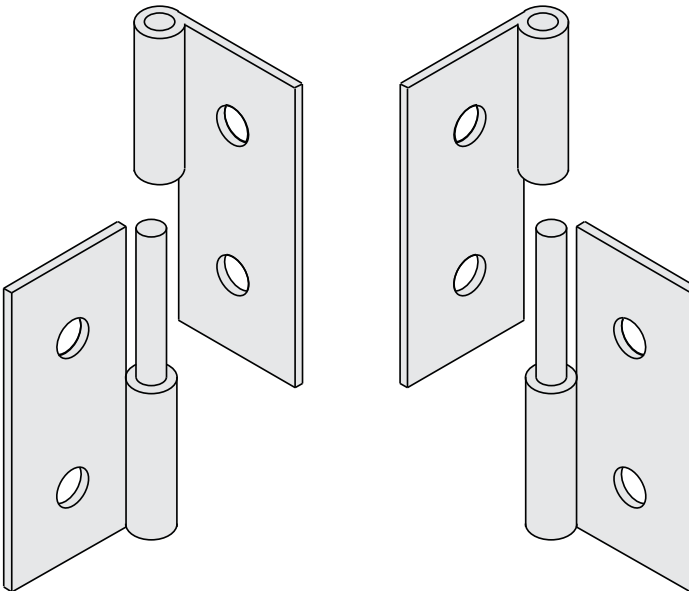

**EF-21LH Left Hand**

**EF-21RH Right Hand**

**Hardware Included**

**Material - Steel  
Finish - Zinc Plated**



# Hidden Steel Hinge (.33" slot size)



**EF-70**

**5/16" SLOTS**

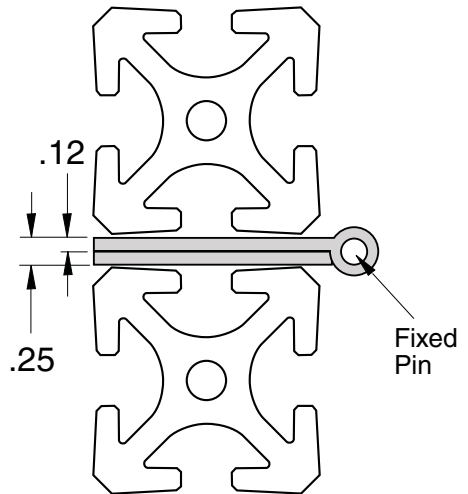
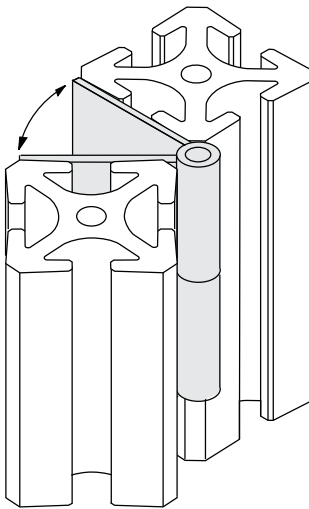
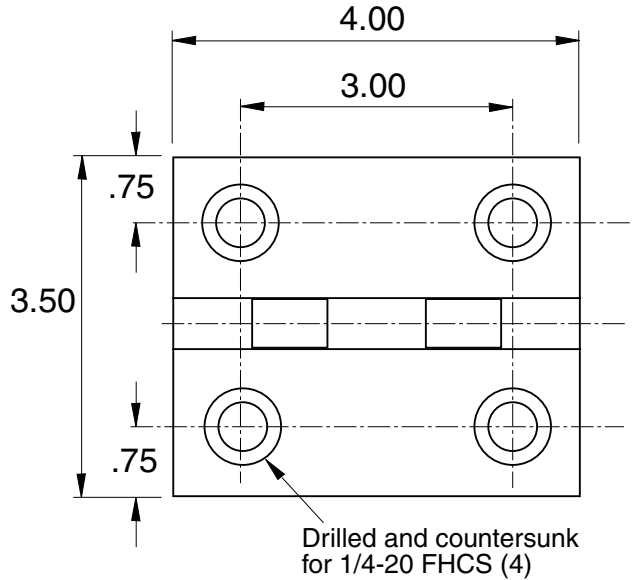

Hardware Included

Material - Steel  
Finish - Black Powder Coat

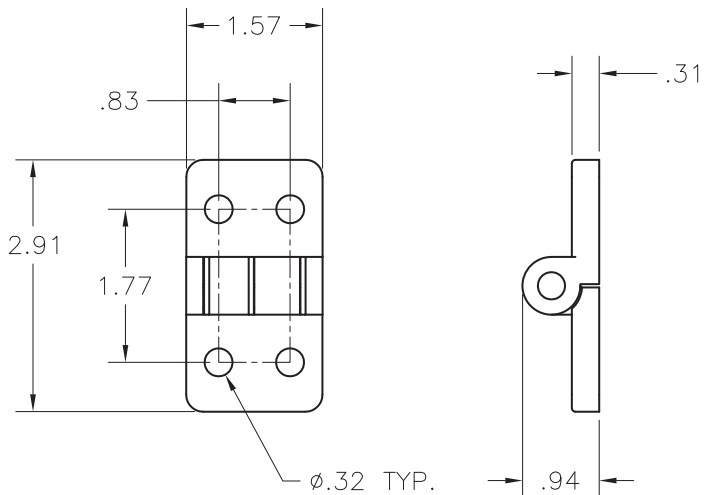

5/16" SLOTS

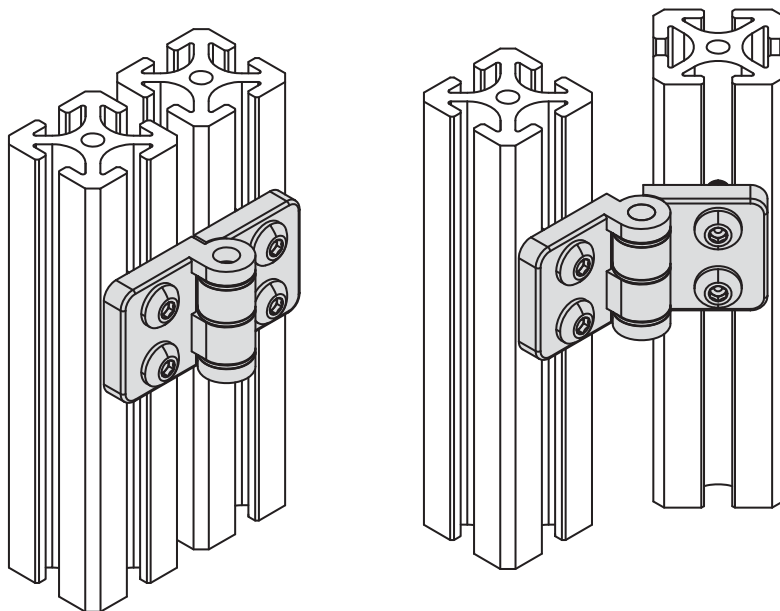

Hardware Included

Material - Zinc Die Cast  
Finish - Black Powder Coat

# Die Cast Zinc Locking Hinge



**EF-74**

**5/16" SLOTS**

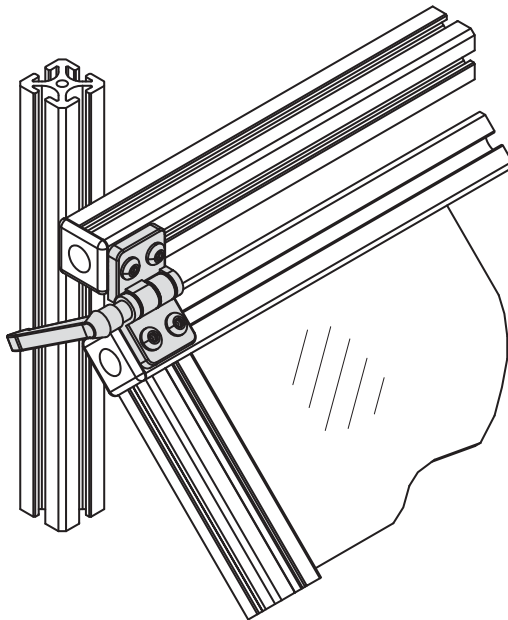
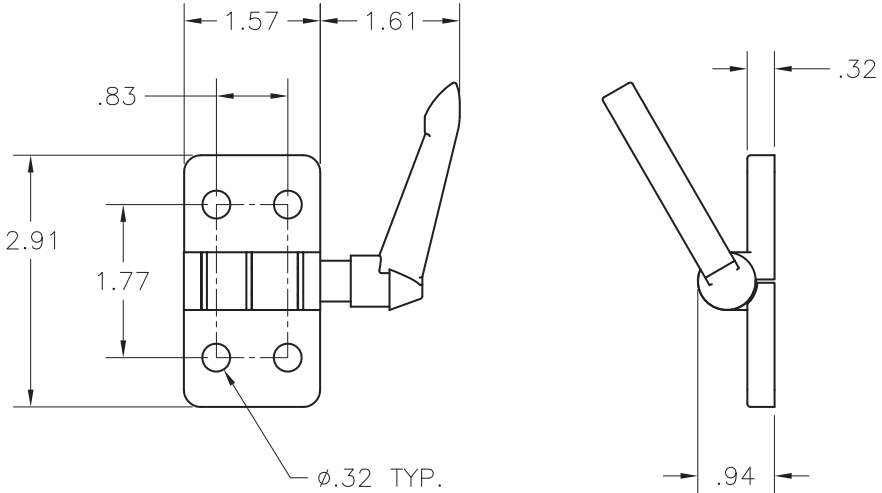

Hardware Included

Material - Zinc Die Cast  
Finish - Black Powder Coat

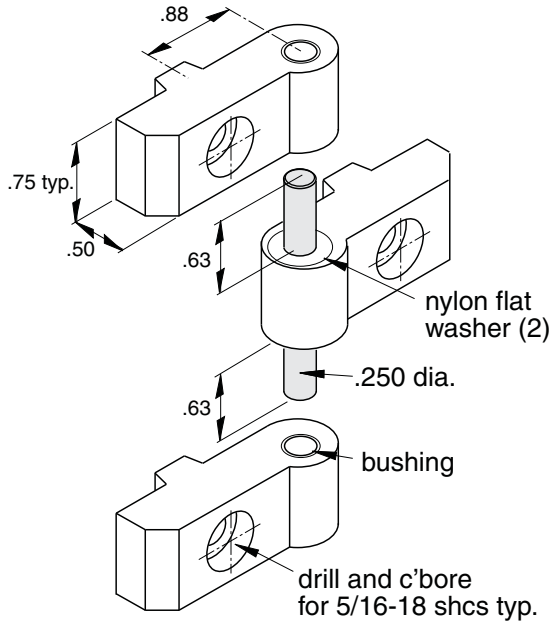

**5/16" SLOTS**

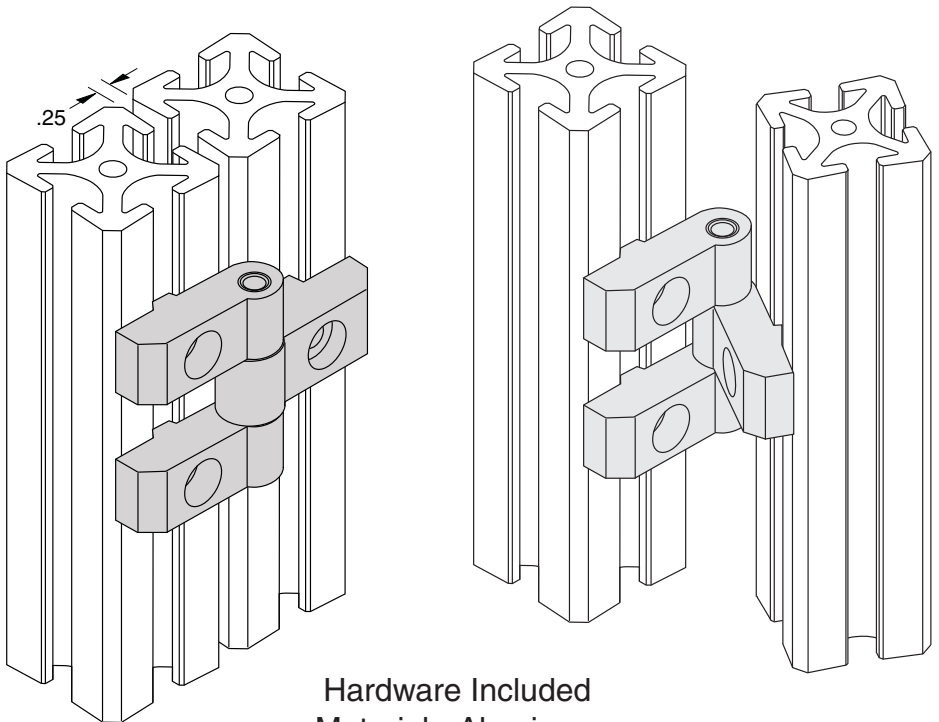

**Hardware Included**  
**Material - Aluminum**  
**Finish - Clear Anodize**

# Left Hand Lift-Off Hinge - 5/16" slots



<b>EB-132</b>	One Set w/Long & Short Pin Assemblies
<b>EB-132L</b>	Long Pin Assembly Only
<b>EB-132S</b>	Short Pin Assembly Only

5/16" SLOTS

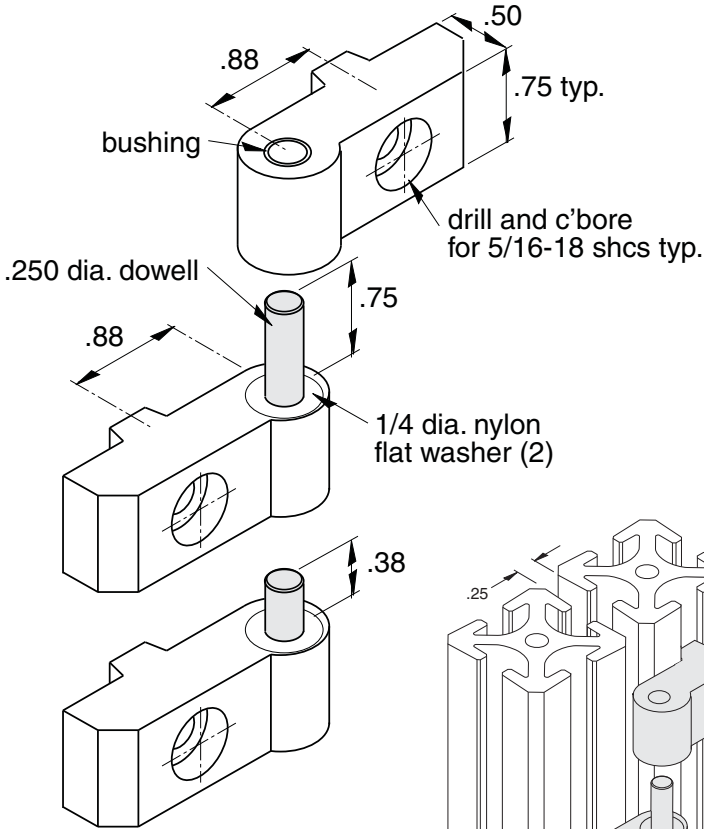

**Hardware Included**  
**Material - Aluminum**  
**Finish - Clear Anodize**

**Note:** Use short and long pin assemblies together as shown to ease lift-off and replacement of doors.

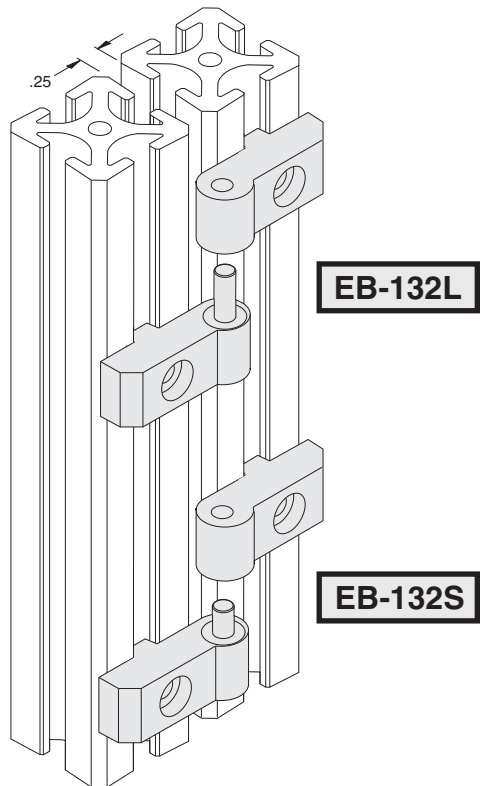

One Set w/Long & Short Pin Assemblies

**EB-133**

Long Pin Assembly Only

**EB-133L**

Short Pin Assembly Only

**EB-133S**

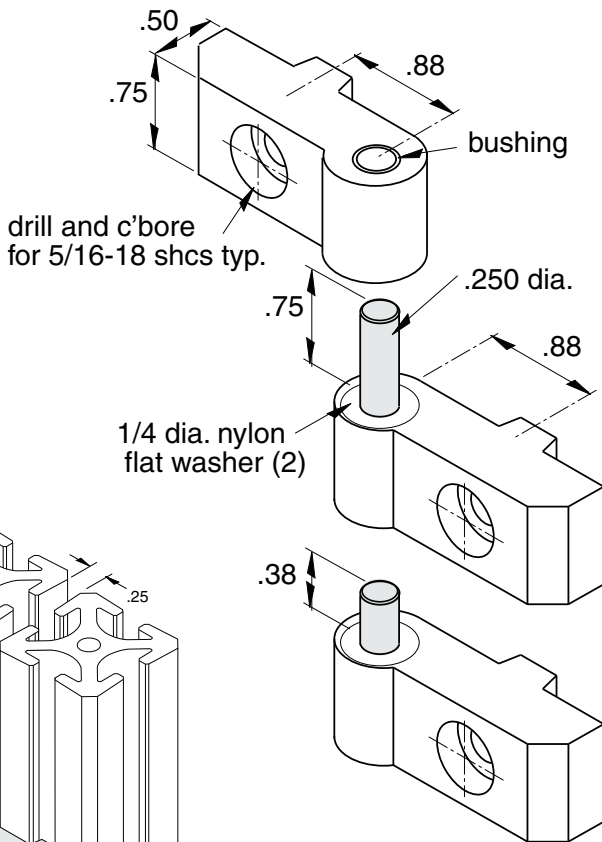

**5/16" SLOTS**

**EB-133L**

**EB-133S**

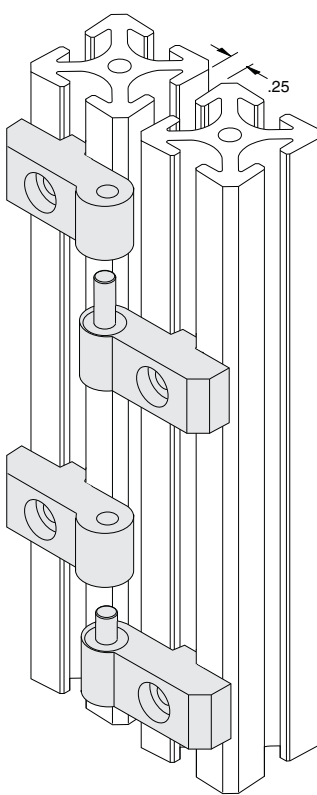

**Hardware Included**  
Material - Aluminum  
Finish - Clear Anodize

**Note:** Use short and long pin assemblies together as shown to ease lift-off and replacement of doors.

# Heavy Duty Transition 5/16 - 1/4 slots Hinge Assembly



**EB-140**

5/16" SLOTS

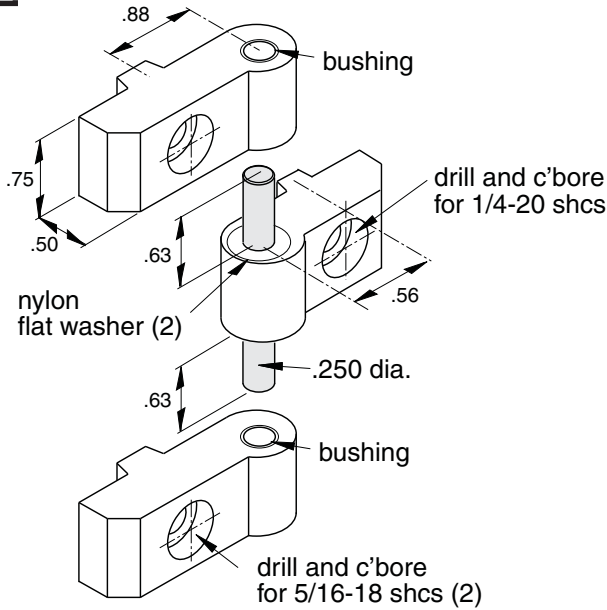

**EX-11**

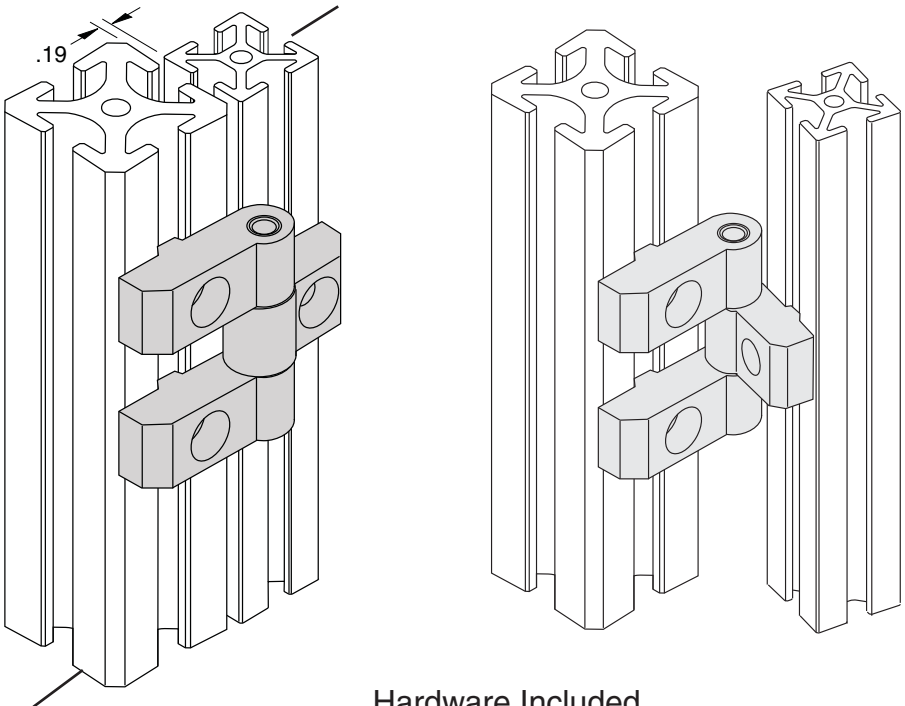

**EX-1**

Hardware Included  
Material - Aluminum  
Finish - Clear Anodize

One Set w/Long & Short Pin Assemblies

**EB-142**

Long Pin Assembly Only

**EB-142L**

Short Pin Assembly Only

**EB-142S**

Hardware Included  
Material - Aluminum  
Finish - Clear Anodize

**Note:** Use short and long pin assemblies together as shown to ease lift-off and replacement of doors.

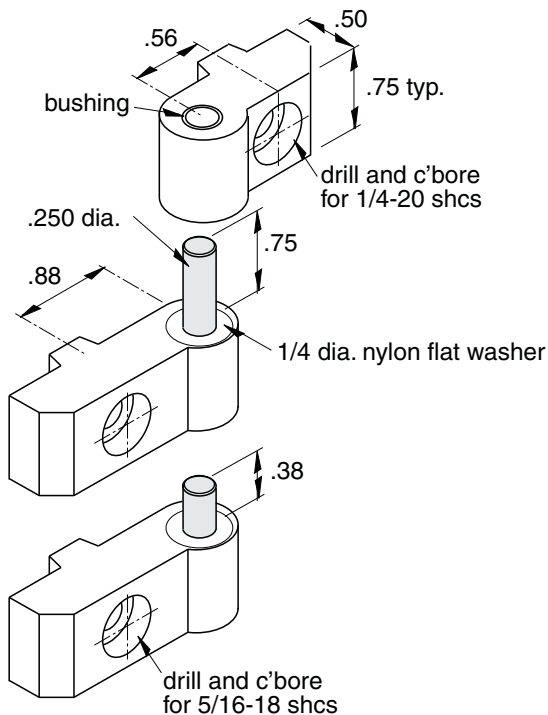

**5/16" SLOTS**

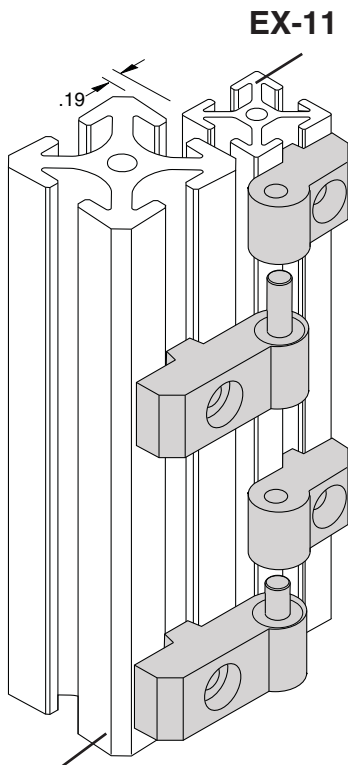

**EB-142L**

**EB-142S**

**EX-1**



# Right Hand Transition Lift-Off Hinge 5/16 - 1/4 slots



<b>EB-143</b>
<b>EB-143L</b>
<b>EB-143S</b>

One Set w/Long & Short Pin Assemblies  
 Long Pin Assembly Only  
 Short Pin Assembly Only

5/16" SLOTS

Hardware Included  
 Material - Aluminum  
 Finish - Clear Anodize

**Note:** Use short and long pin assemblies together as shown to ease lift-off and replacement of doors.

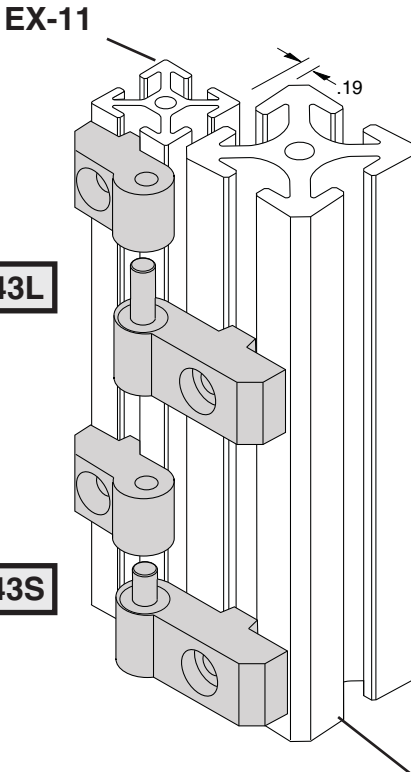
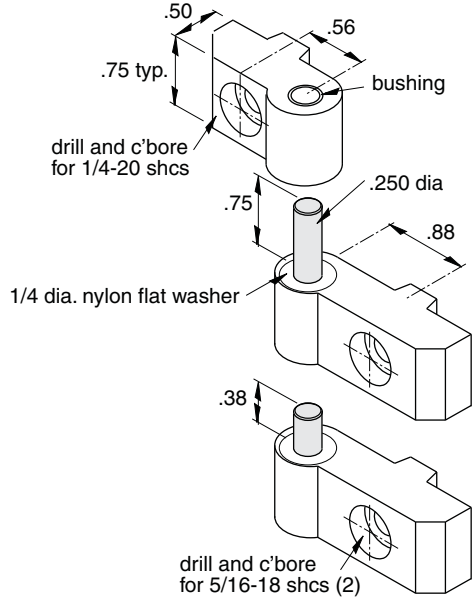

**EB-143L**

**EB-143S**

**EX-1**

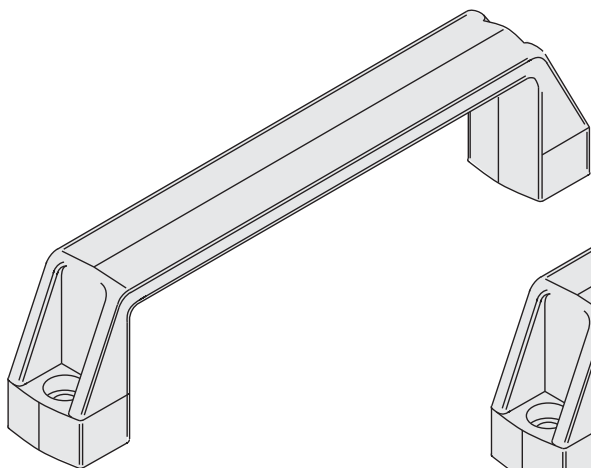

**EF-15C**

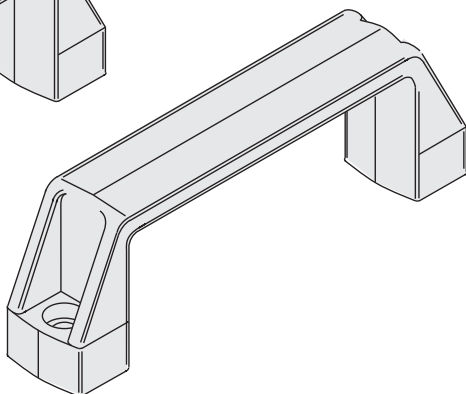

**EF-15B**

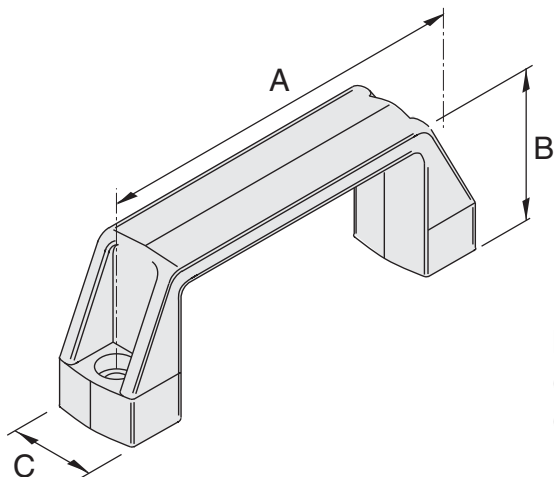

**EF-15A**

Recommended  
Hardware  
(2) EF-11-.75 SHCS  
(2) EF-2 T-nut

Material - Black Plastic

Part No.	A	B	C
<b>EF-15A</b>	4.61	1.61	1.06
<b>EF-15B</b>	5.20	1.77	1.02
<b>EF-15C</b>	7.05	1.97	1.10

# Offset Extrusion Door Handle



**EF-48**

**5/16" SLOTS**

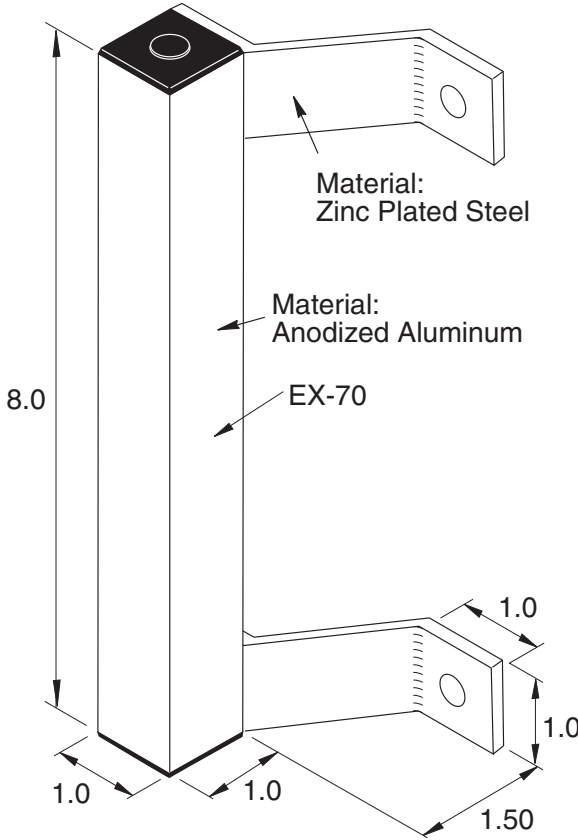

Hardware Included

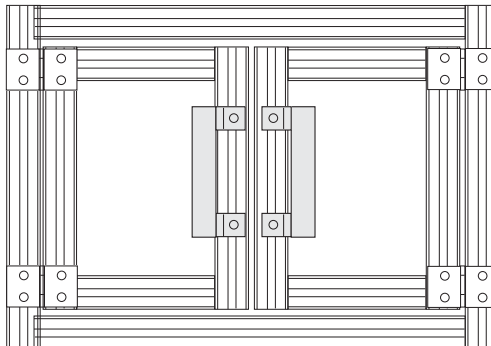
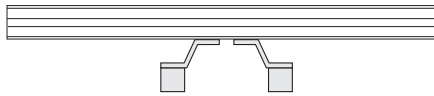

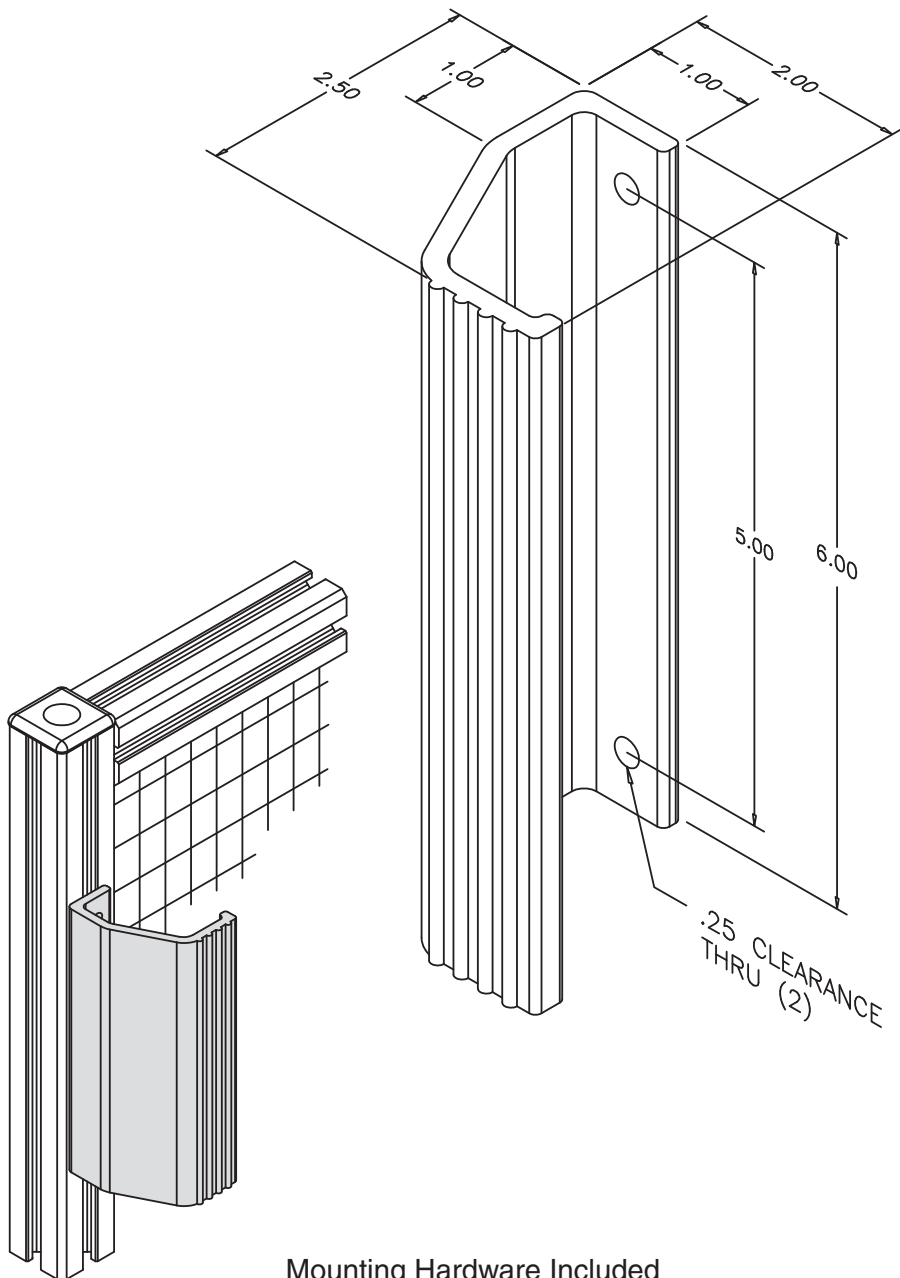

Material - Aluminum  
Finish - Black Powder Coat

# Extruded Door Handle



**EF-181**

**5/16" SLOTS**

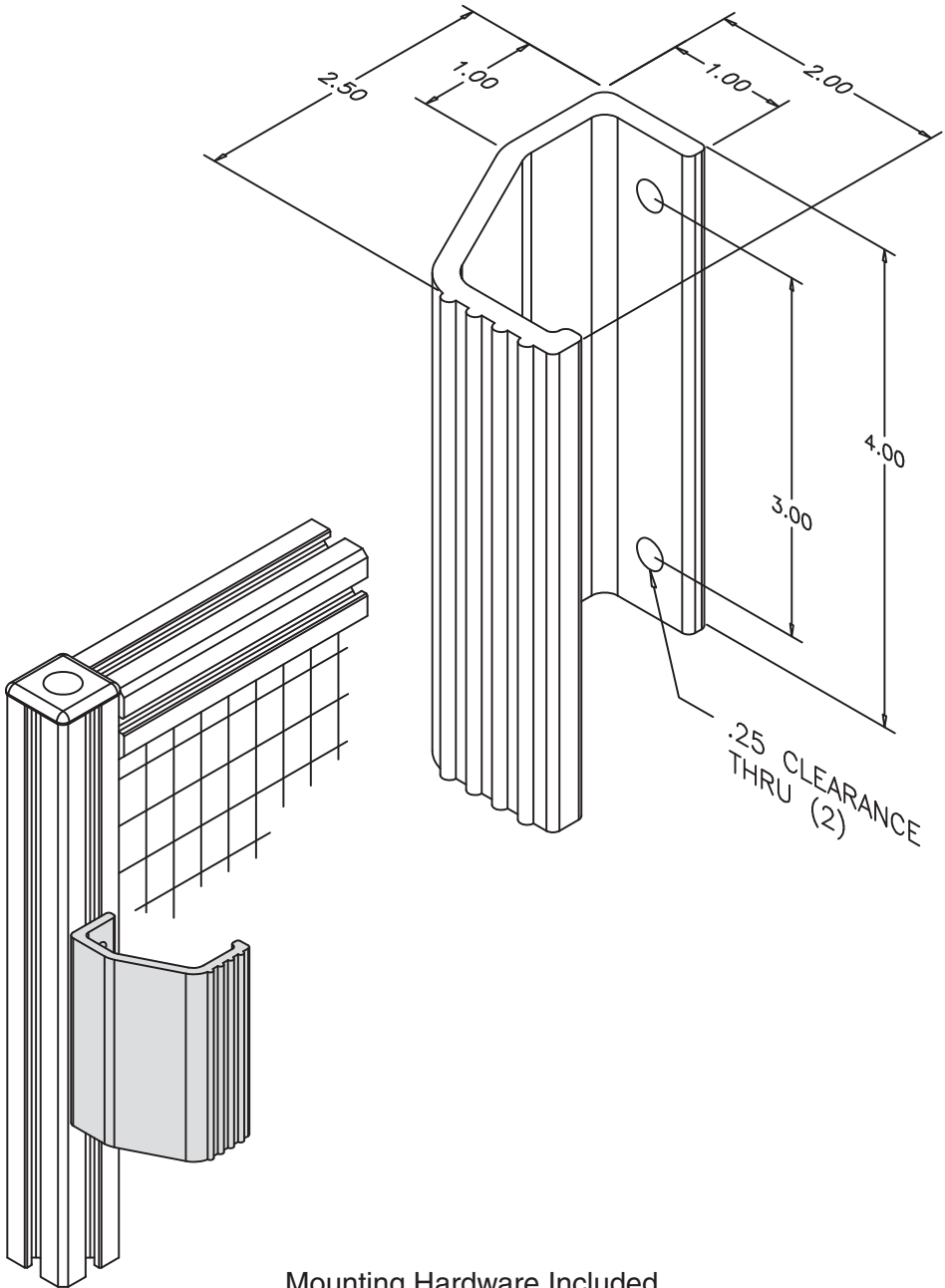

Mounting Hardware Included

Material - Aluminum  
Finish - Black Powder Coat

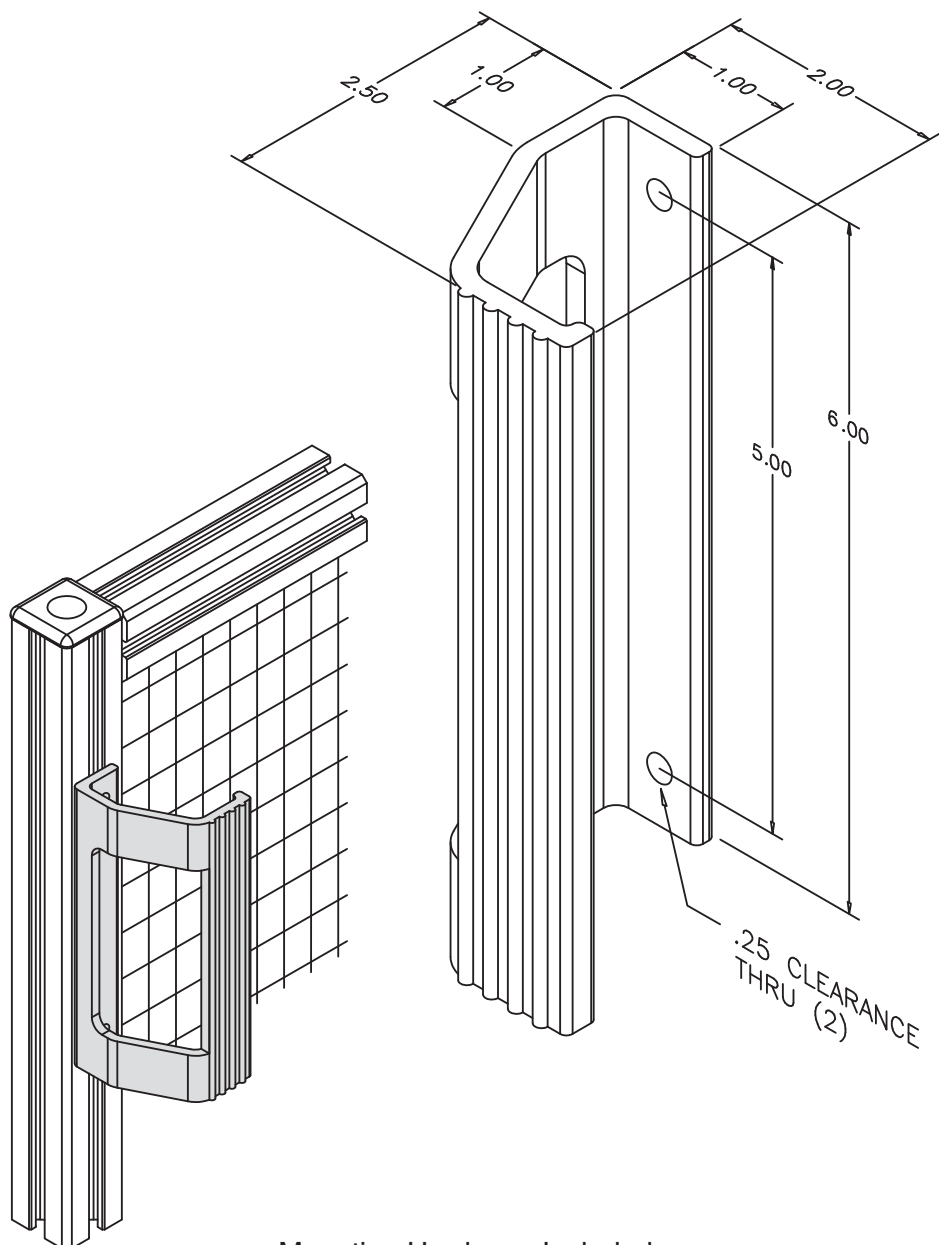

Mounting Hardware Included

Material - Aluminum  
Finish - Black Powder Coat

# Safety Door Handle



<b>EF-125</b>
<b>EF-126</b>
<b>EF-127</b>

**5/16" SLOTS**

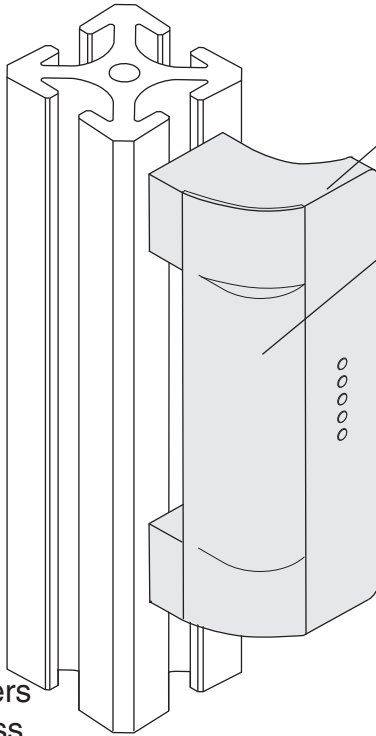

Black Handle Base

Colored Bolt Cover

- EF-125** Black Cover
- EF-126** Yellow Cover
- EF-127** Orange Cover

Note: Fingers will not pass through

**Recommended Hardware**  
 For 5/16" slot sizes, use:  
 (2) 11-222 & (2) EF-2A  
  
 For 1/4" slot sizes, use:  
 (2) 11-221 & (2) 11-210

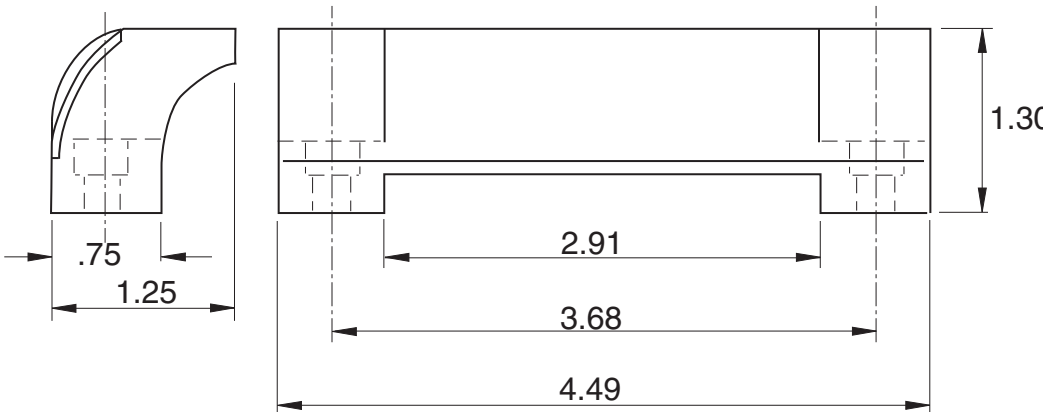

Material - Plastic

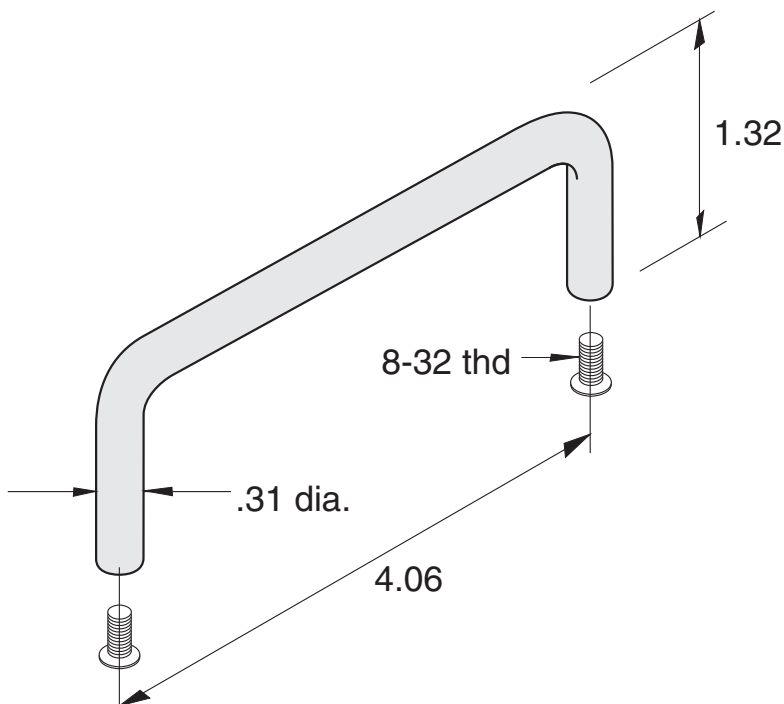
**5/16" SLOTS**

Hardware Included

Note: 8-32 bolt length determined by panel thickness

Material - Aluminum  
Finish - Clear Anodize



**EF-40**

5/16" SLOTS

Hardware included

**EF-40A**

Non-Locking

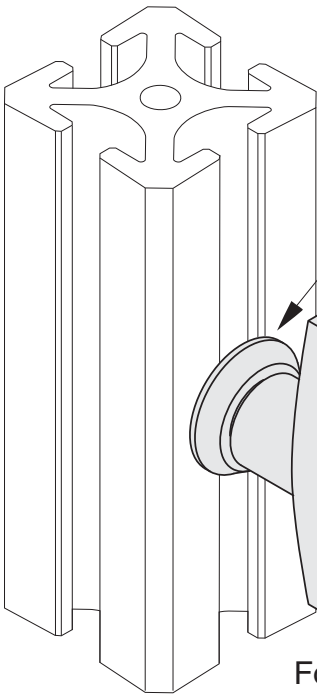
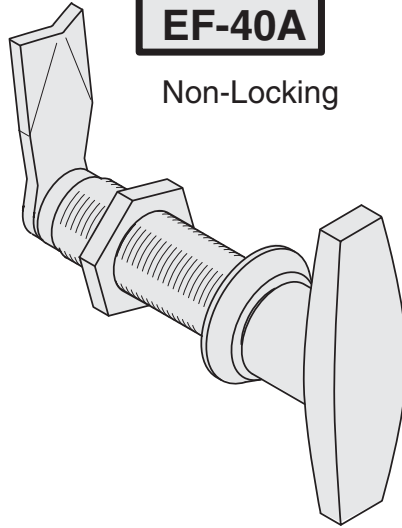

.875 dia mounting hole

**EF-40B**

Locking

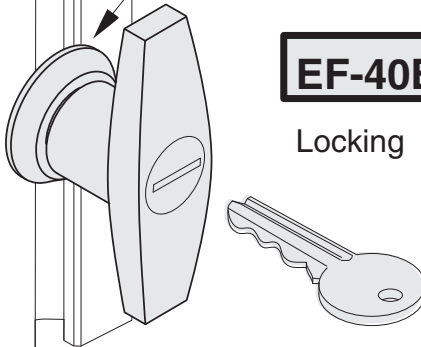

For factory supplied mounting hole,  
order EF-40H and provide hole location

Material - Steel  
Handle Finish - Black Powder Coat

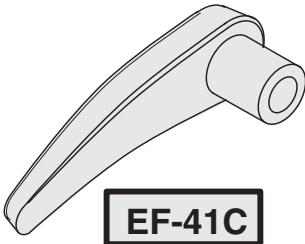

**EF-41C**

Inside Handle

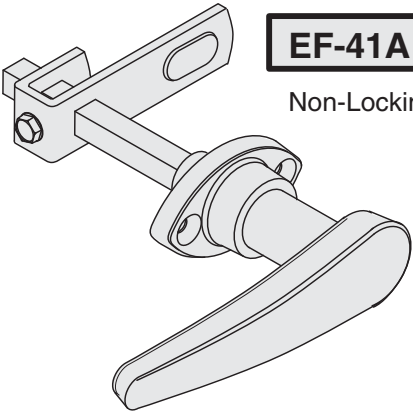

**EF-41A**

Non-Locking

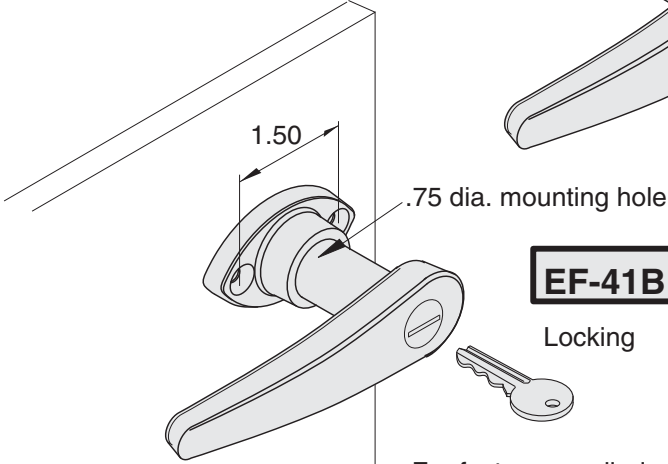

**EF-41B**

Locking

For factory supplied mounting holes, order EF-41H and provide hole location

**5/16" SLOTS**

Material - Steel  
Handle Finish - Chrome

**EF-32**

5/16" SLOTS

**EF-32-1, L= .78**  
**EF-32-2, L=1.25**

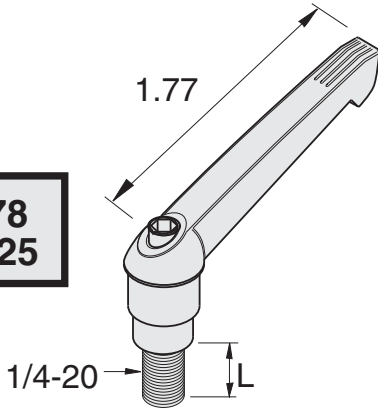

**EF-32-3, L= .78**  
**EF-32-4, L=1.25**

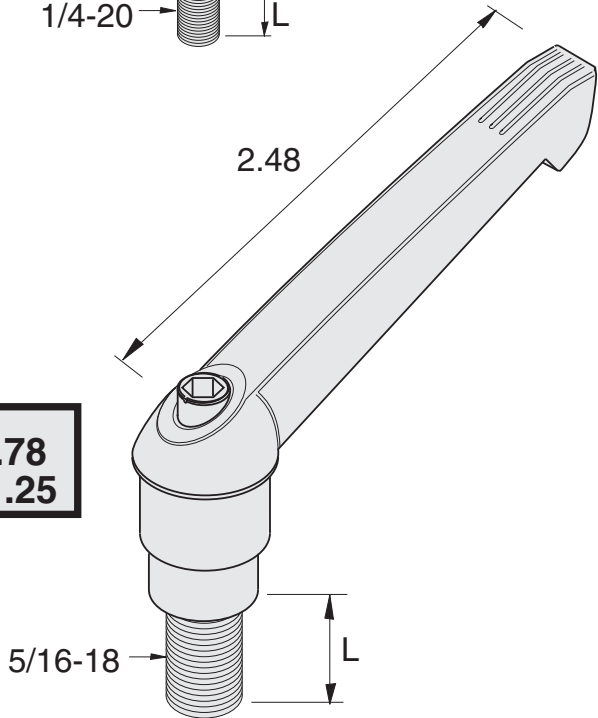

Handle Material - Plastic

**EF-33-1**

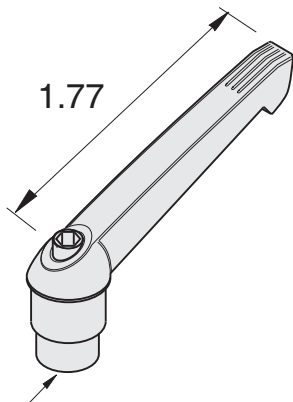

tapped for  
1/4-20

**EF-33-2**

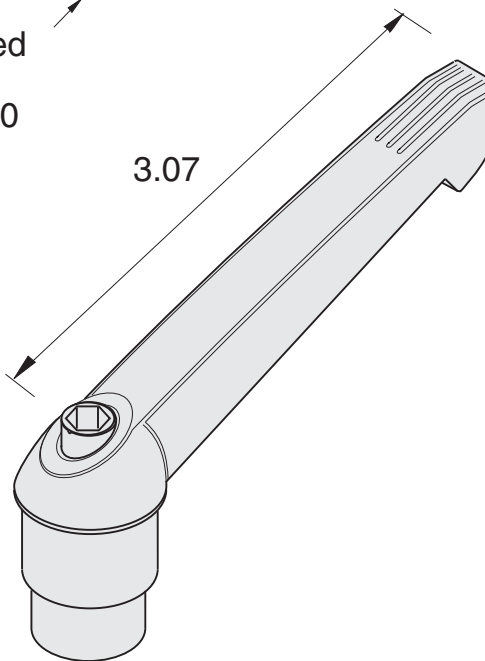

tapped for  
5/16-18

**5/16" SLOTS**

Handle Material - Plastic

**EB-35**

5/16" SLOTS

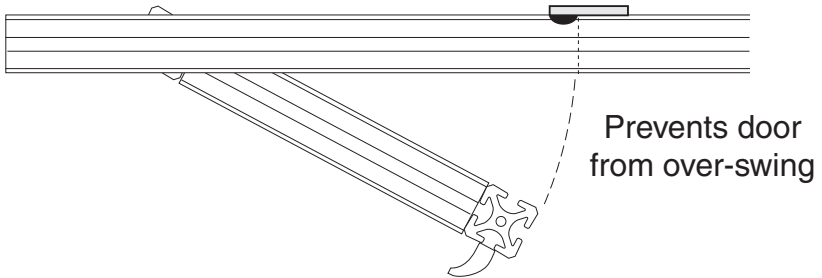
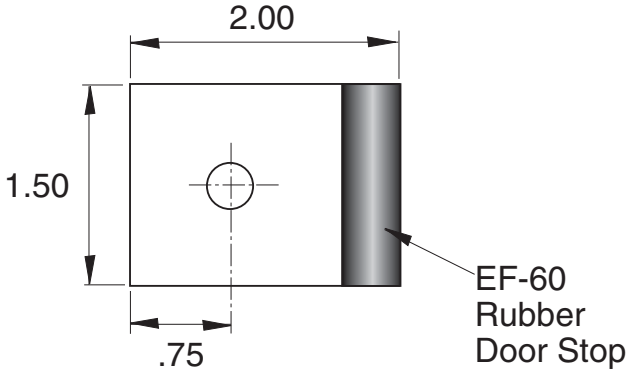

- Recommended  
Hardware
- (1) EF-12-.63 BHCS
  - (1) EF-1 Pivot T-nut

Material - Aluminum  
Finish - Clear Anodize

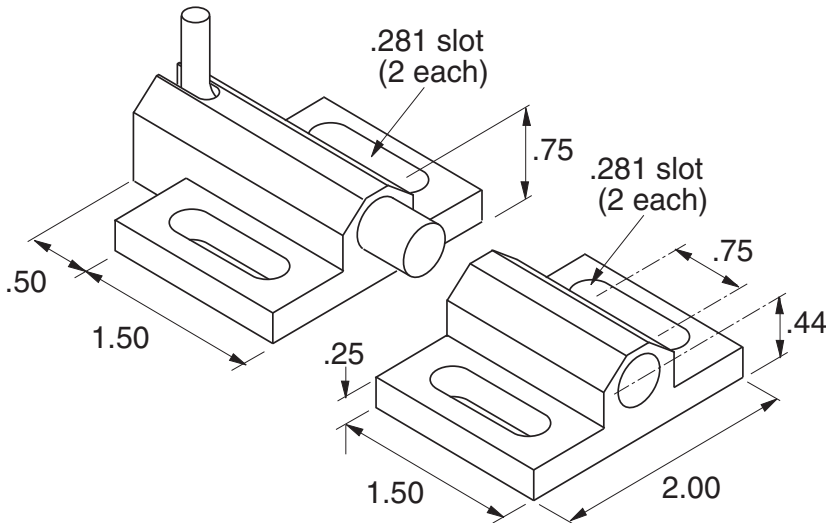

**5/16" SLOTS**

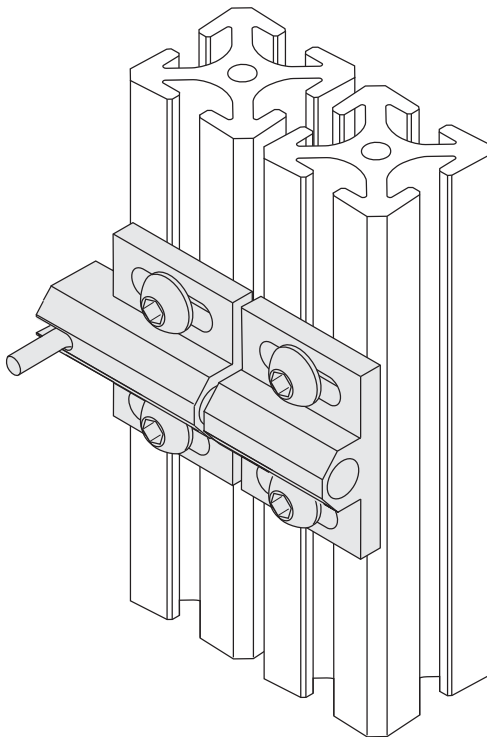

**Hardware Included**

**Material:**  
**Mounting Plates:**  
Aluminum , Clear Anodize  
**Dead Bolt:**Zinc Plated Steel

# Deadbolt Latch



**EF-171**

**.375 dia. Bolt**

**5/16" SLOTS**

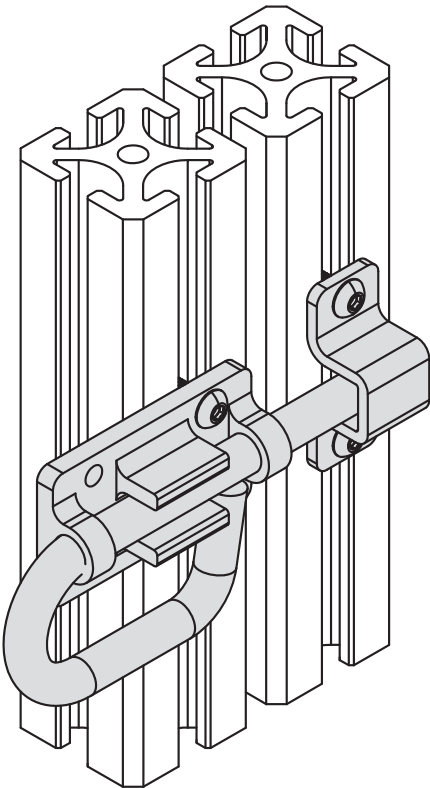
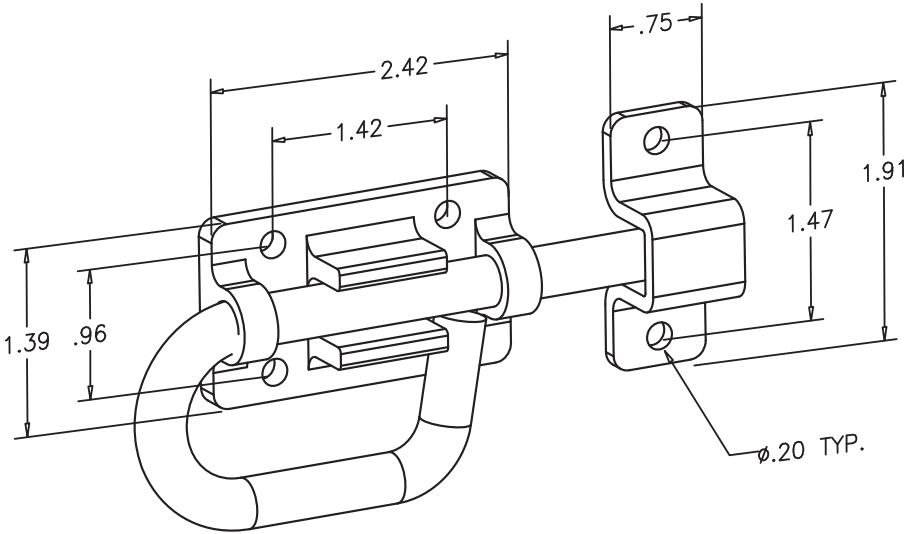

Hardware Included

Use with 5/16" slot extrusions

Material - Zinc Plated Steel

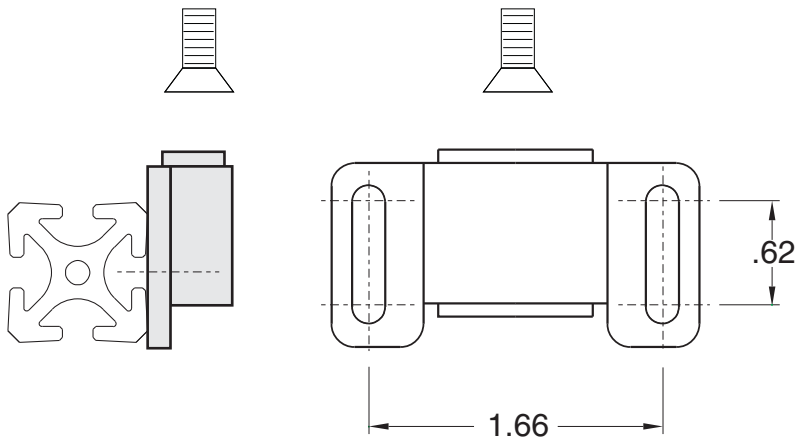

**5/16" SLOTS**

includes 1/4-20 FHCS striker and all hardware



**Heavy Duty Magnetic  
Door Latch Assembly**



**EF-22HD**

**5/16" SLOTS**

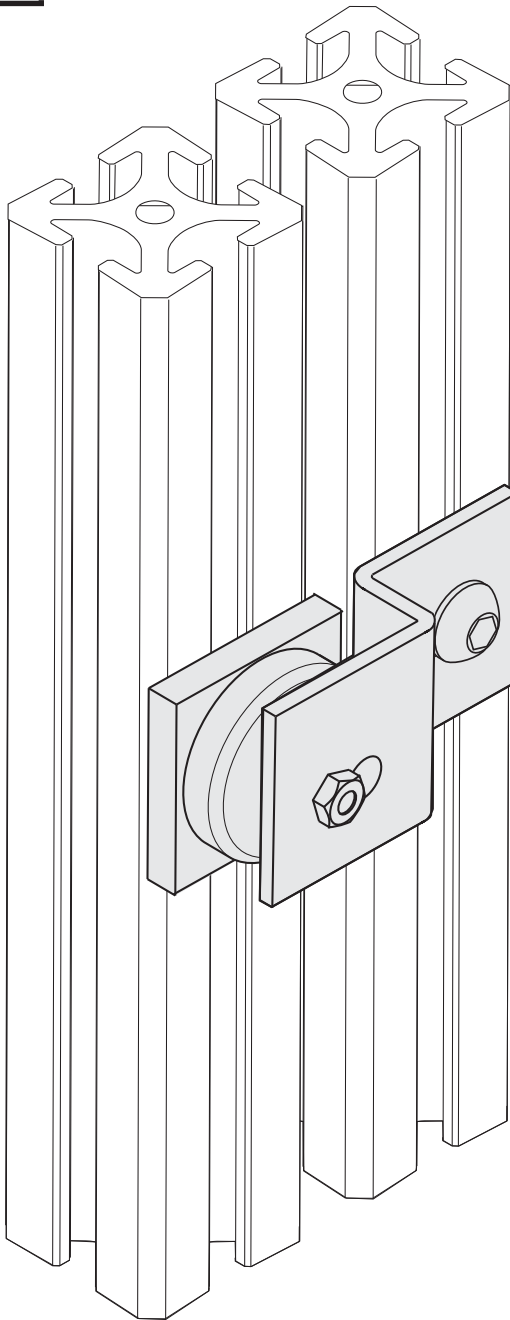

Hardware  
Included

Our most  
popular latch.

**Material - Steel**  
**Finish - Zinc Plate and Black Powder Coat**

**5/16" SLOTS**

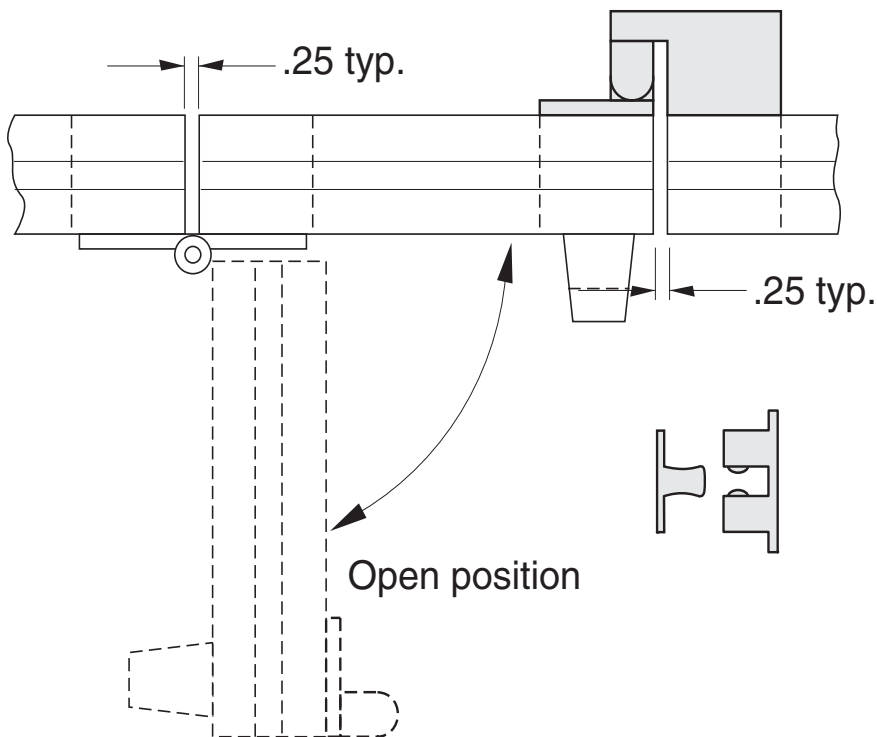

Use with 1 1/2" extrusions (5/16" slot size)

Hardware Included

Catch Material - Zinc Plated Brass

Base Material - Aluminum

# Mechanical Door Latch 5/16" Slots



**EF-78**

excludes EX-52 & EX-54

Adjustable  
Tension

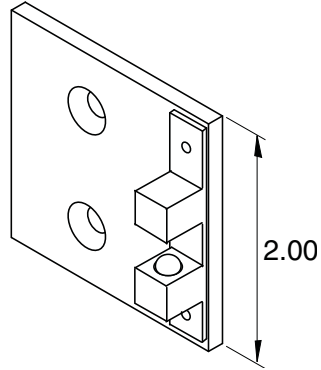
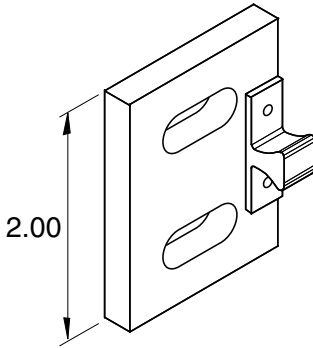

5/16" SLOTS

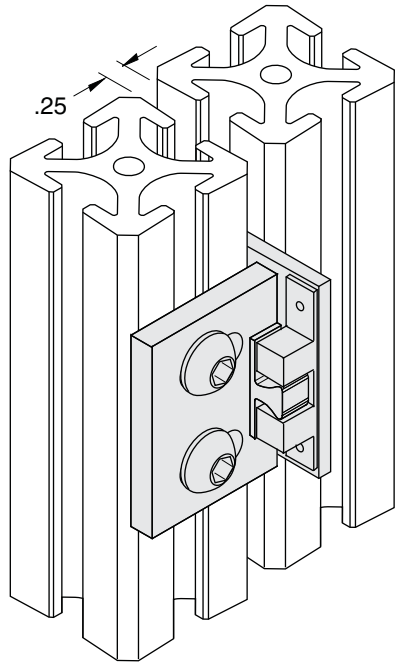
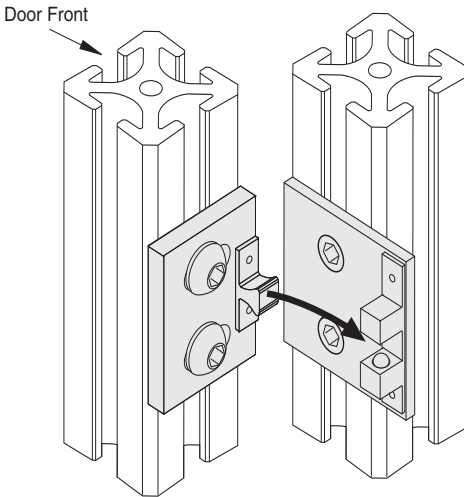

Hardware Included  
Material Mounting Plates: Aluminum , Clear Anodize  
Latch: Zinc Plated Brass

**5/16" SLOTS**

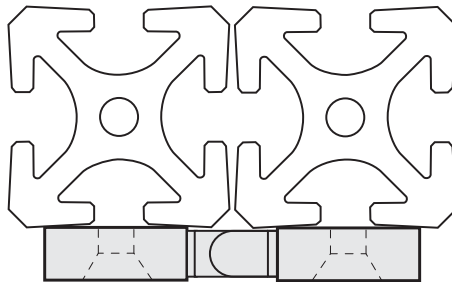
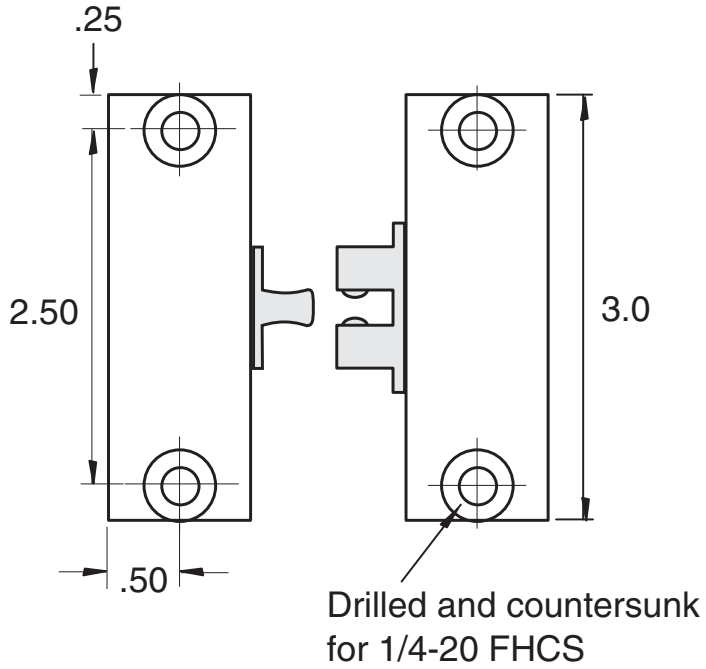

**Hardware Included**

**Catch Material - Zinc Plated Brass**  
**Base Material - Aluminum (Clear Anodized)**

# Bearing Block (Plastic)



**EF-34**

5/16" SLOTS

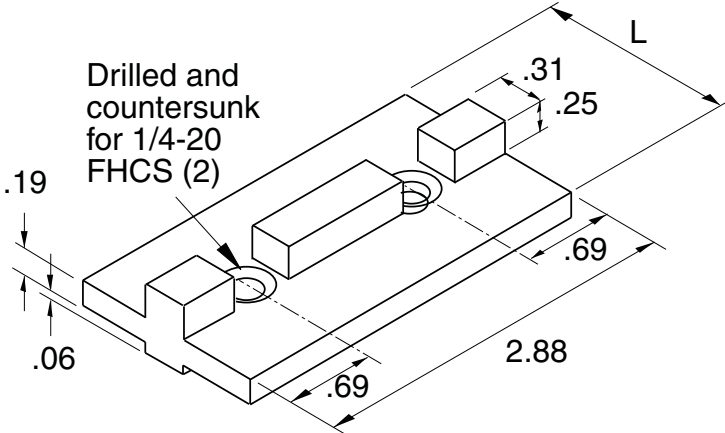

**EF-34A L=1.50**  
**EF-34B L=1.0**

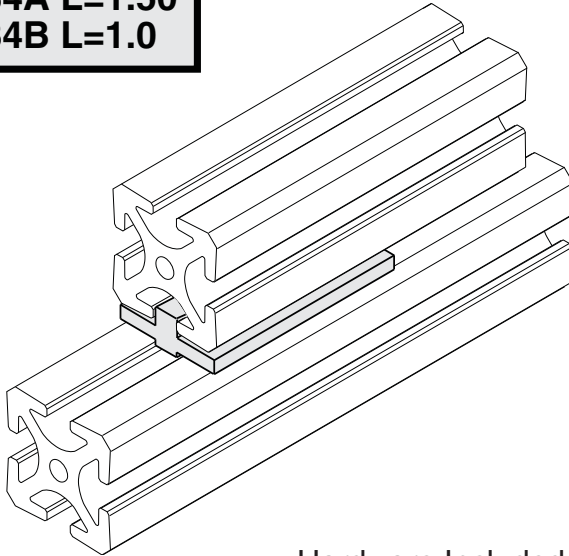

Hardware Included

Bearing Material - DELRIN (white)

**EF-35**

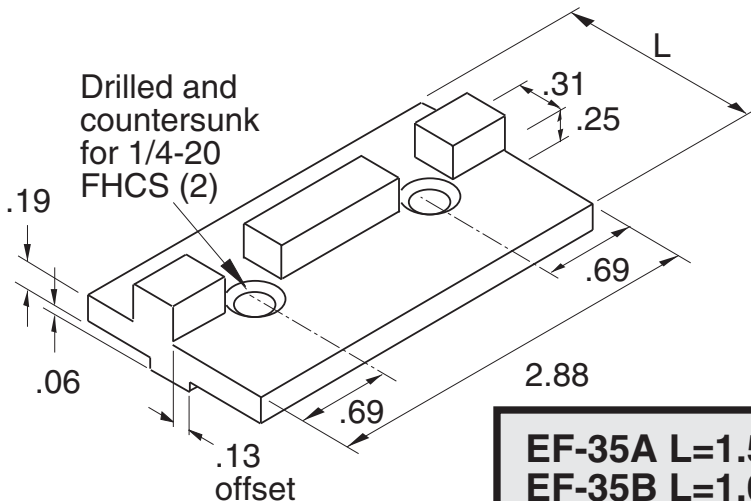

**EF-35A L=1.50**  
**EF-35B L=1.0**

**5/16" SLOTS**

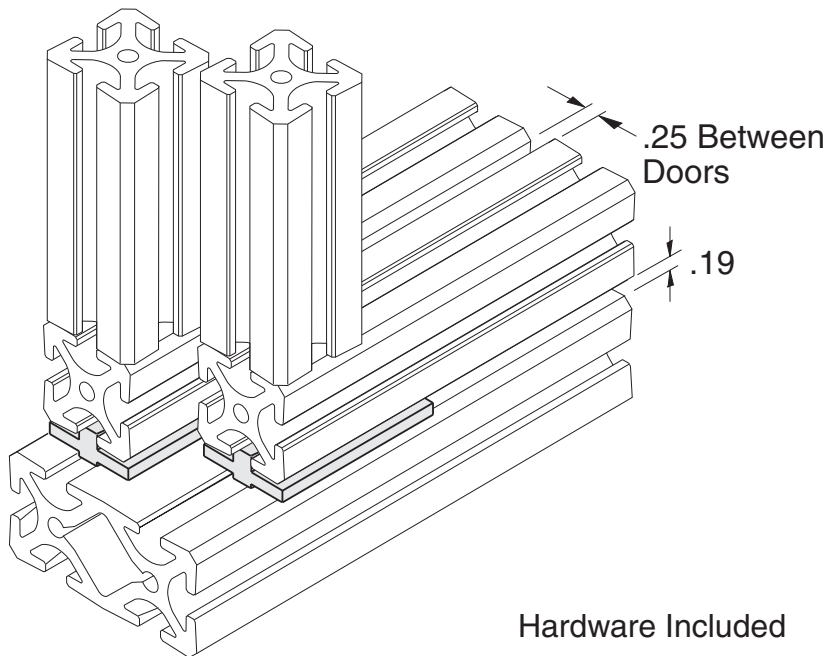

Hardware Included

Load Capacity = 50 lbs.

Bearing Material - DELRIN (white)

**EF-36**

5/16" SLOTS

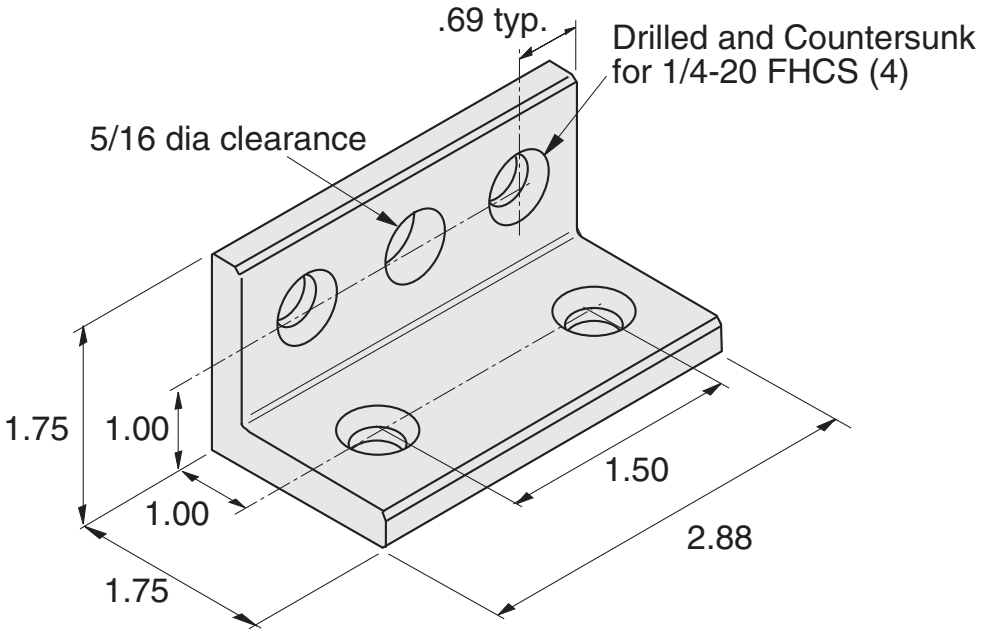

Note: See part no EB-38 for example

Recommended  
Hardware  
(4) EF-157-.63  
(2) EF-2A T-nut

Material - Aluminum  
Finish - Clear Anodize

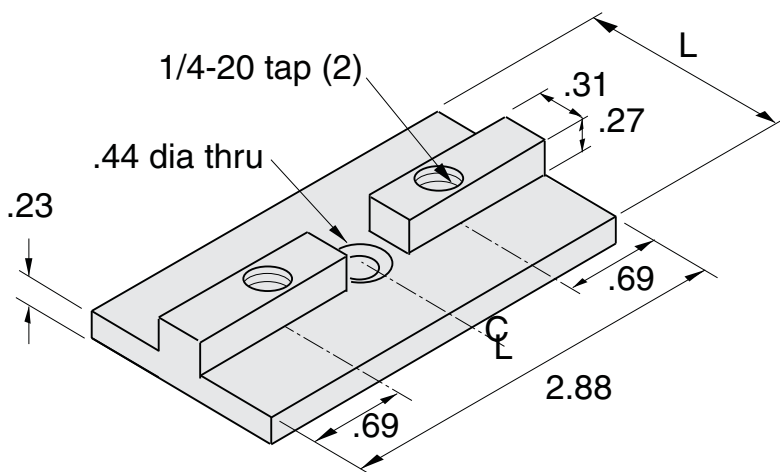

5/16" SLOTS

**EF-37A L=1.50**  
**EF-37B L=1.0**

Load Capacity = 50 lbs.

Bearing Material - DELRIN (white)



# Slider Assembly



<b>EF-38</b>	Slider Assembly (as shown)
<b>EF-38S</b>	Slider Assembly (less clamp handle for sliding only)

5/16" SLOTS

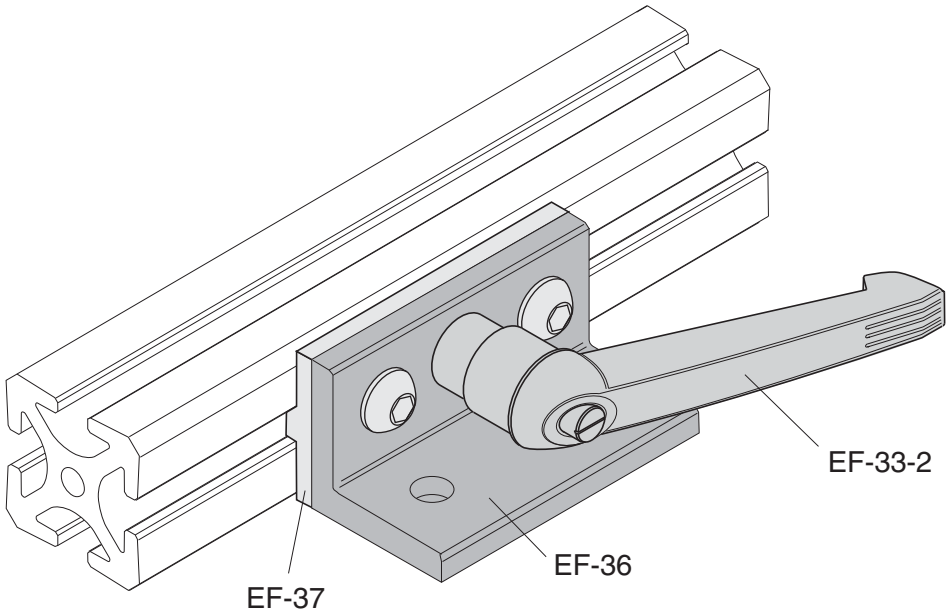

Recommended  
Hardware  
(2) EF-157-.63  
(2) EF-2A T-nut

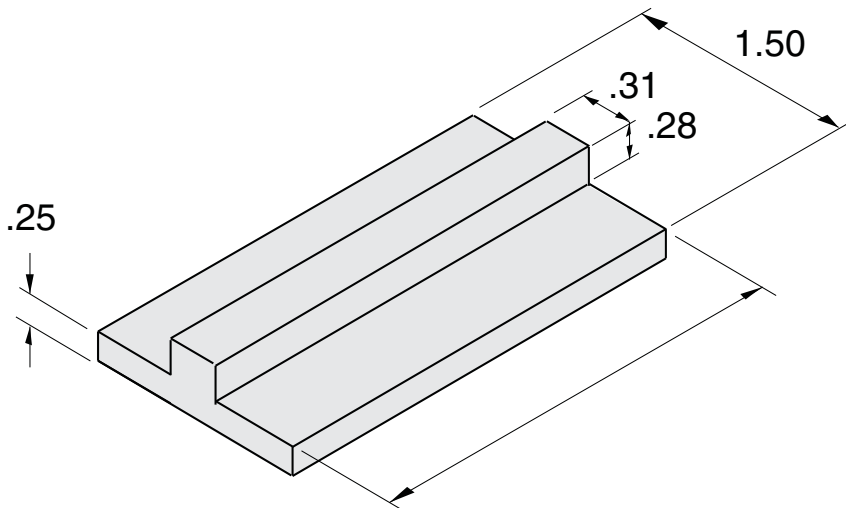

**5/16" SLOTS**

Standard length  
is 60" and 120" —  
sold by the inch.

Material - UHMW (white)

**Blank Hanging Slider Track  
5/16" Slot Size**



**EF-77**

**5/16" SLOTS**

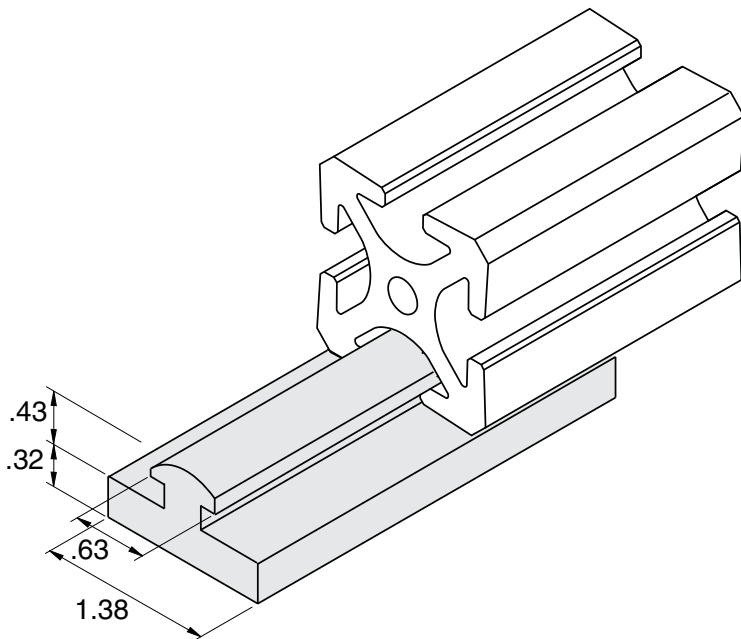

Material - UHMW  
Sold by the inch  
Stock length is 60" & 120"  
Color is Safety Yellow

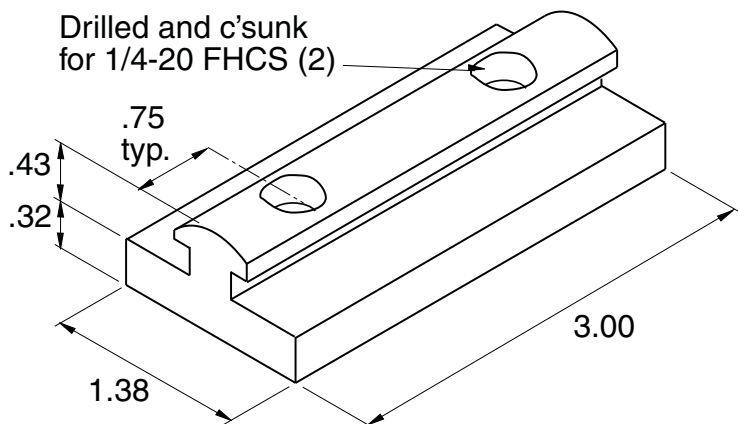

Hardware Included  
Material - UHMW  
Color is Safety Yellow

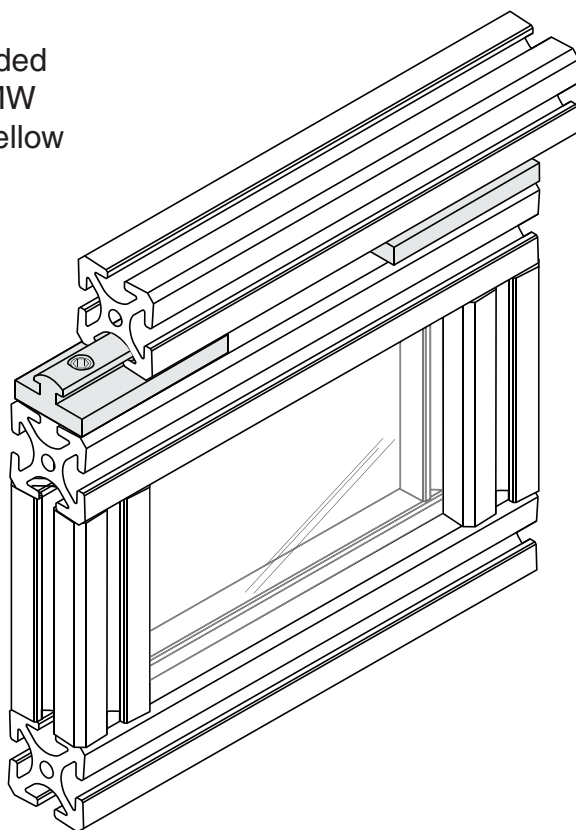

# T-slot Roller



**ER**

**5/16" SLOTS**

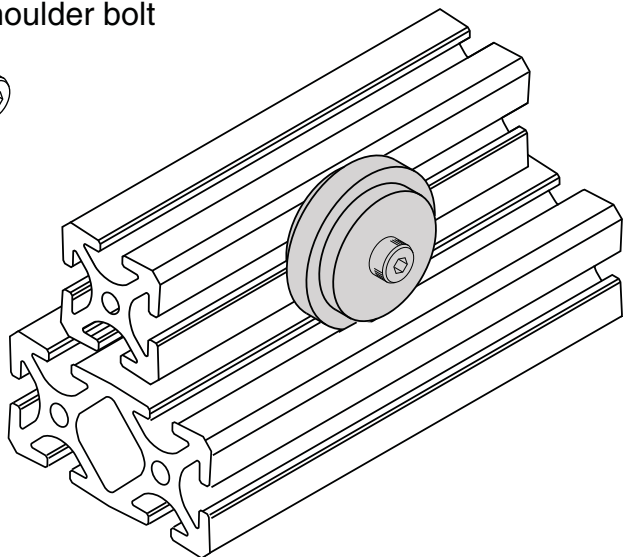
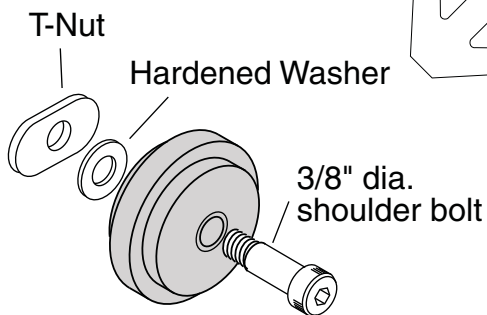
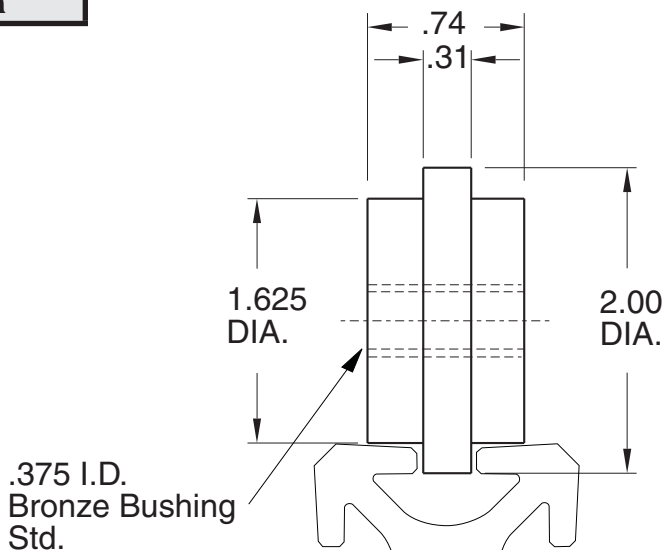

Load Capacity 30 lbs.  
Hardware Included

Material - DELRIN (white)

1/8" offset  
on center

**EF-88**

**EF-89**

**Door Clearance Between Sliders**

- = .25" using (4) EF-88 and (4) EF-35A
- = .13" using (2) EF-88 with (2) EF-35A  
and (2) EF-89 with (2) EF-34A

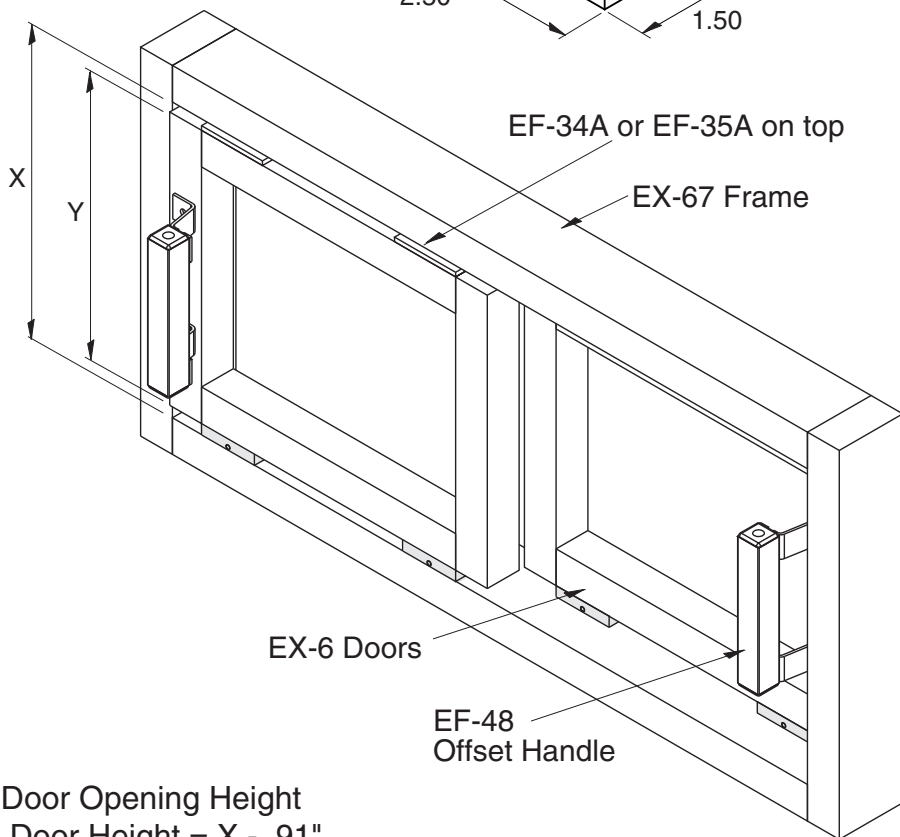
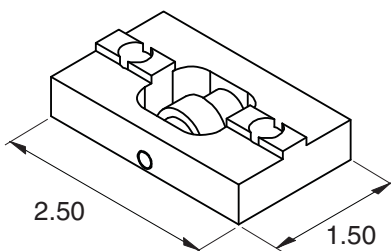

X= Door Opening Height  
Y = Door Height = X - .91"

**Hardware Included**

**5/16" SLOTS**

**ER-BL**

**5/16" SLOTS**

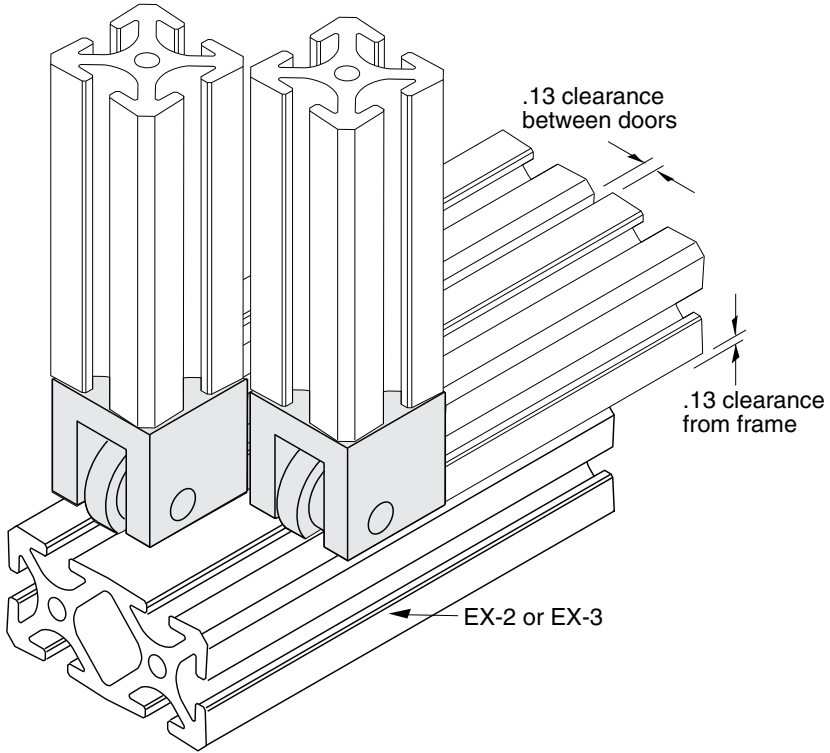

Hardware Included  
Load Capacity 25 lbs.

Roller Material - DELRIN  
Block Material - Aluminum (Clear Anodized)

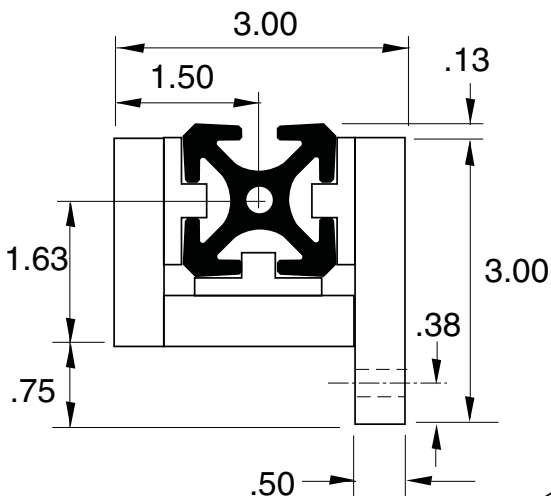

**5/16" SLOTS**

Note: 3-piece design  
for adjustability

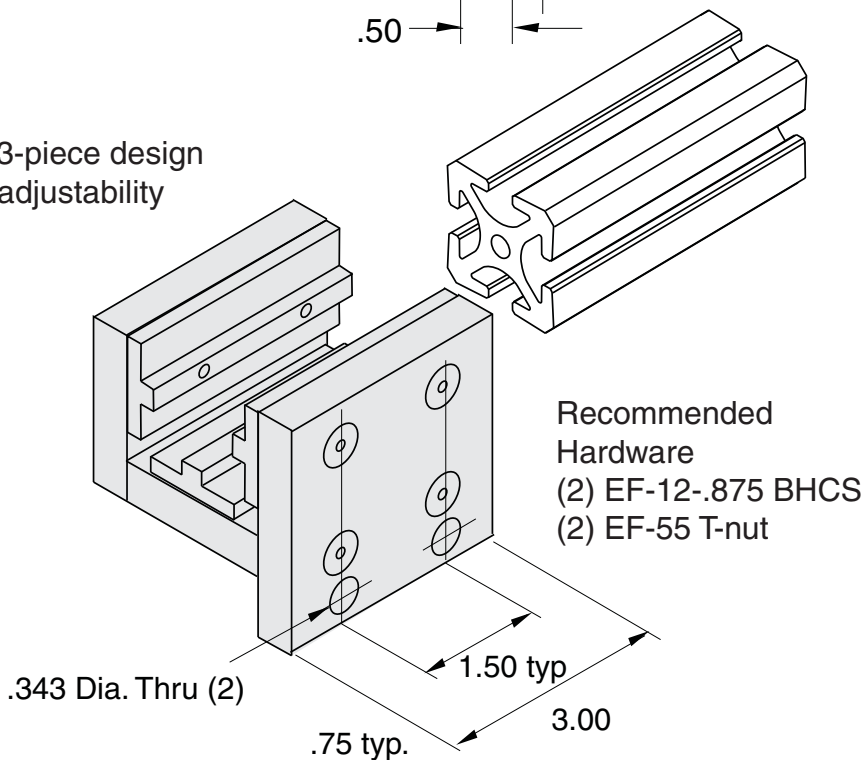

Recommended  
Hardware  
(2) EF-12-.875 BHCS  
(2) EF-55 T-nut

Bearing Material - DELRIN  
Plate Material - Aluminum (Clear Anodized)



# Single Mount Linear Bearing with Locking Handle



**EB-91LH**

5/16" SLOTS

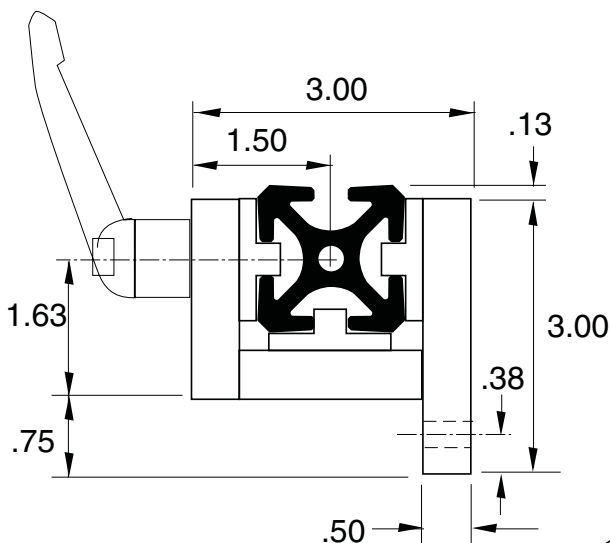

Note: 3-piece design for adjustability

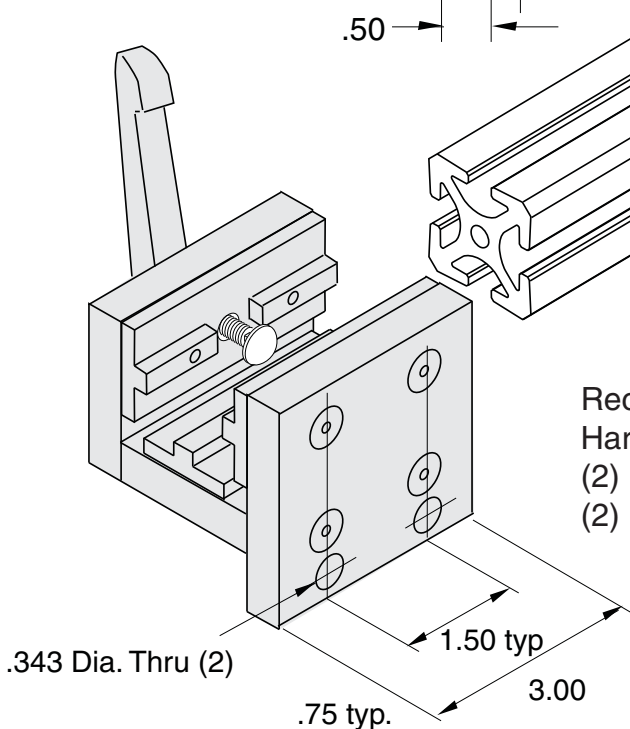

Recommended Hardware  
(2) EF-12-.875 BHCS  
(2) EF-55 T-nut

Bearing Material - DELRIN  
Plate Material - Aluminum (Clear Anodized)

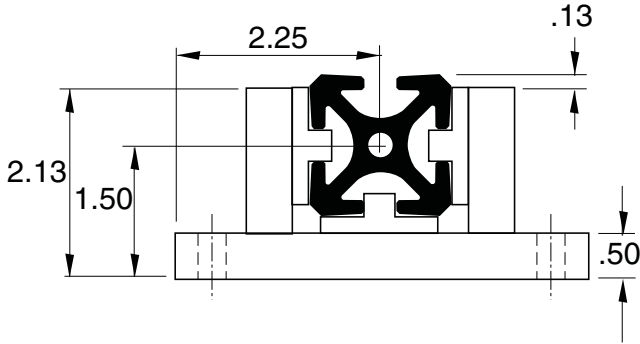

**5/16" SLOTS**

Note: 3-piece design  
for adjustability

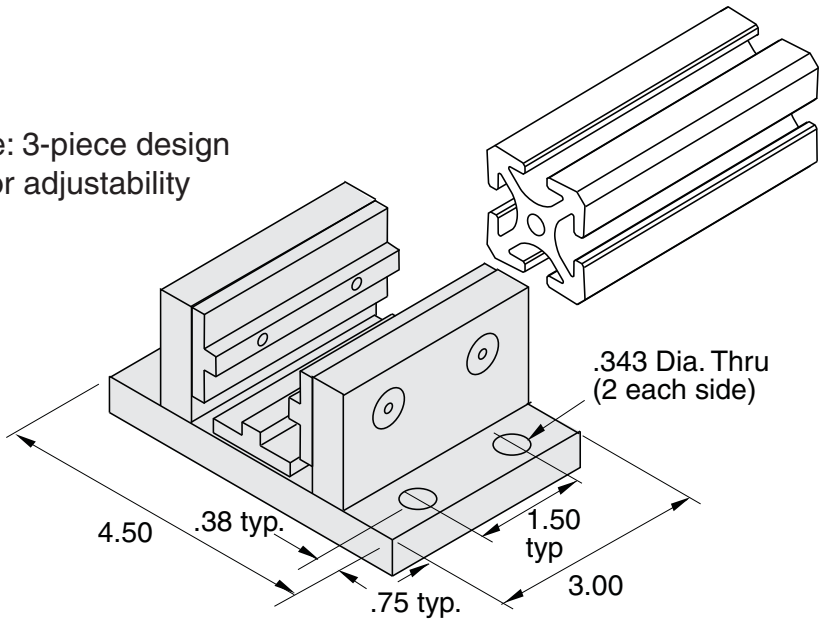

- Recommended  
Hardware
- (4) EF-12-.875 BHCS
  - (4) EF-55 T-nut

Bearing Material - DELRIN  
Plate Material - Aluminum (Clear Anodized)

# Single Mount Linear Bearing with Locking Handle



**EB-93LH**

**5/16" SLOTS**

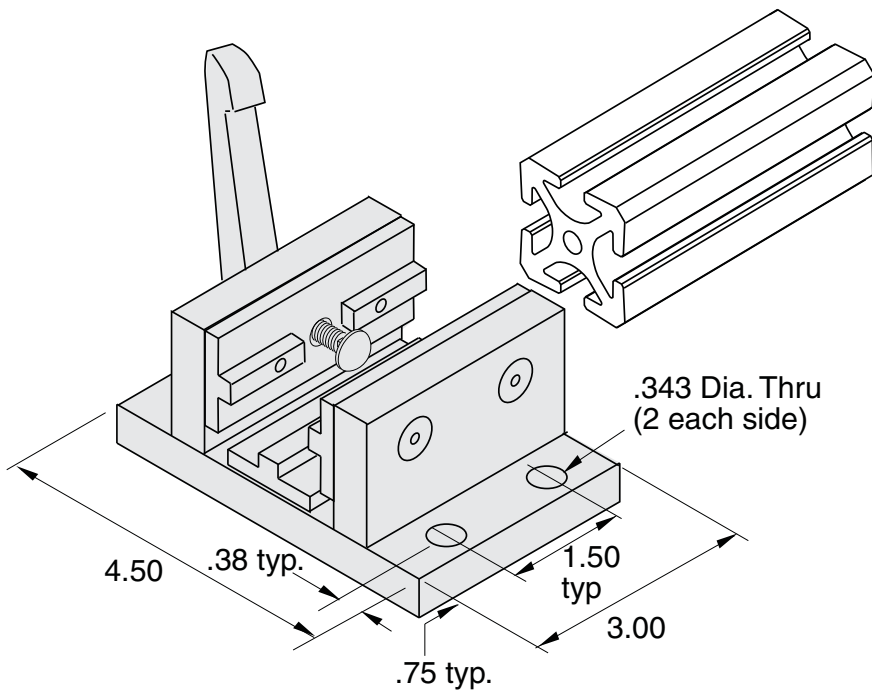
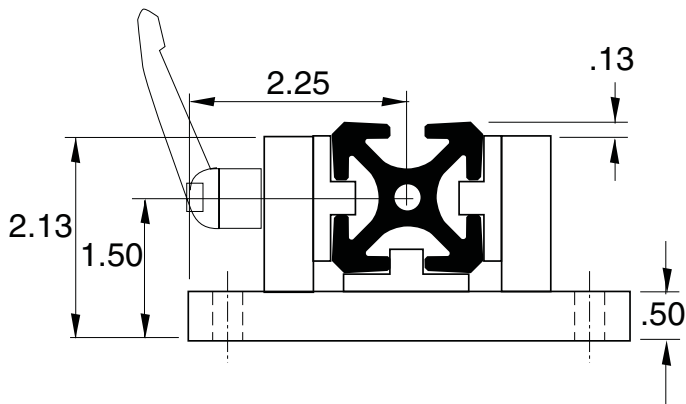

Recommended  
Hardware

- (4) EF-12-.875 BHCS
- (4) EF-55 T-nut

Bearing Material - DELRIN  
Plate Material - Aluminum (Clear Anodized)

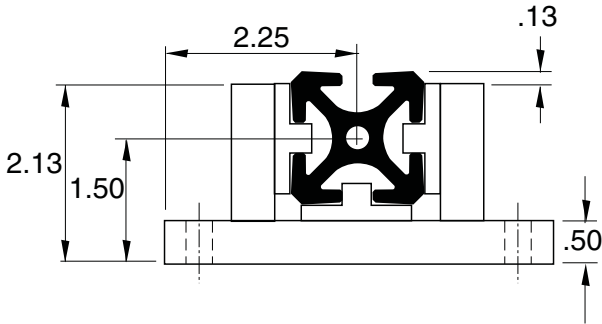

Note: 3-piece design  
for adjustability

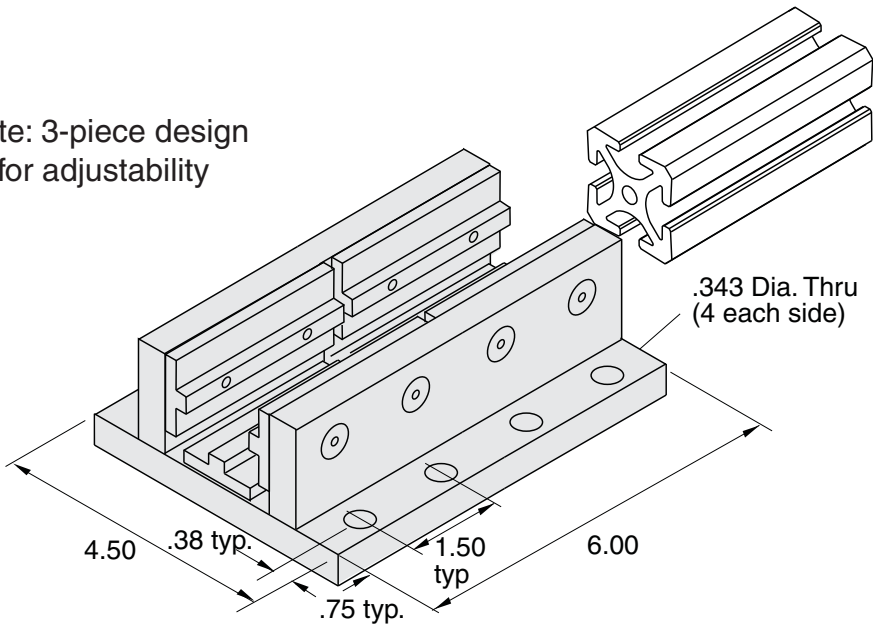

**5/16" SLOTS**

Recommended  
Hardware  
(8) EF-12-.875 BHCS  
(8) EF-55 T-nut

Bearing Material - DELRIN  
Plate Material - Aluminum (Clear Anodized)

# Double Mount Linear Bearing with Locking Handle



**EB-92LH**

**5/16" SLOTS**

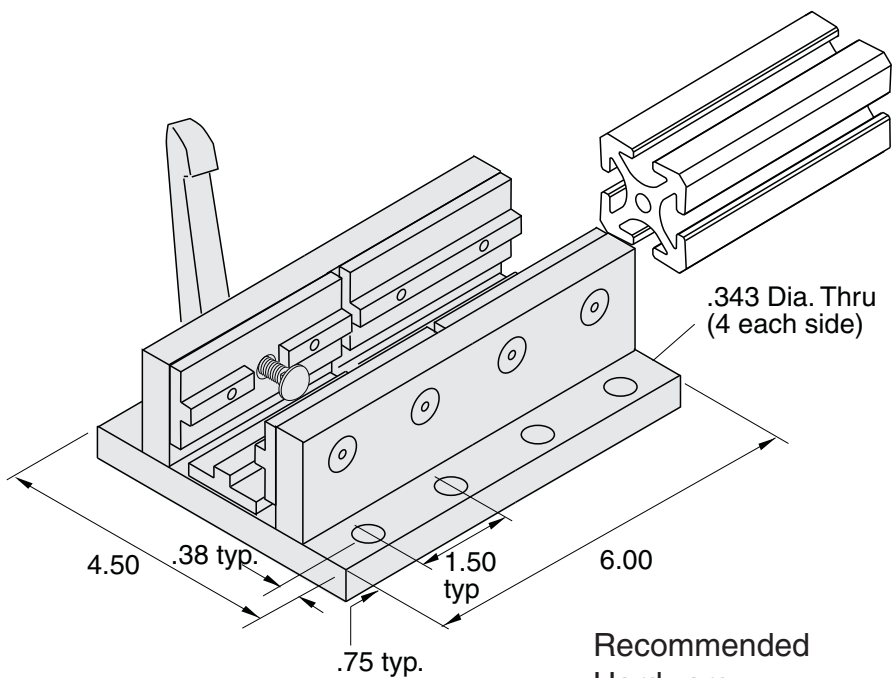
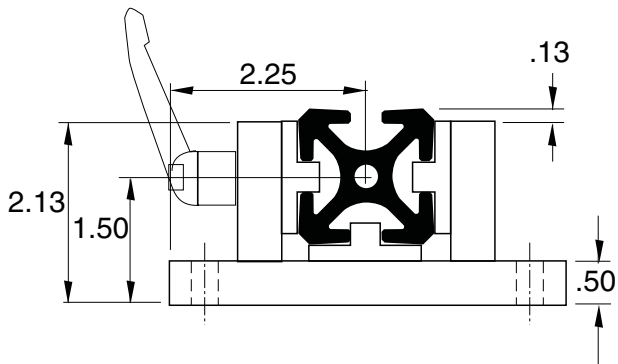

Recommended Hardware  
 (8) EF-12-.875 BHCS  
 (8) EF-55 T-nut

Bearing Material - DELRIN  
 Plate Material - Aluminum (Clear Anodized)

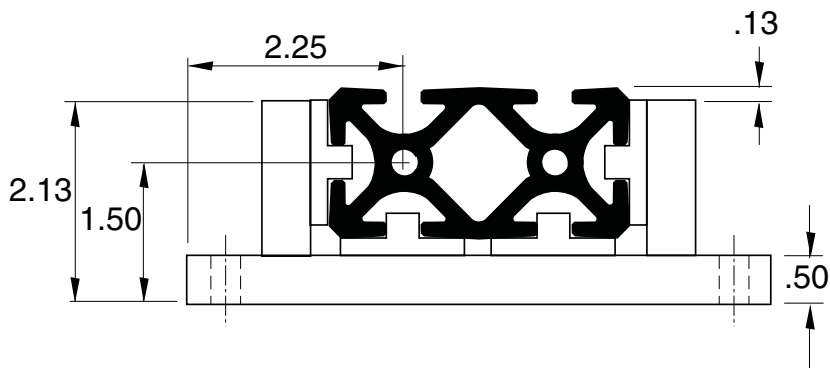

Note: 3-piece design  
for adjustability

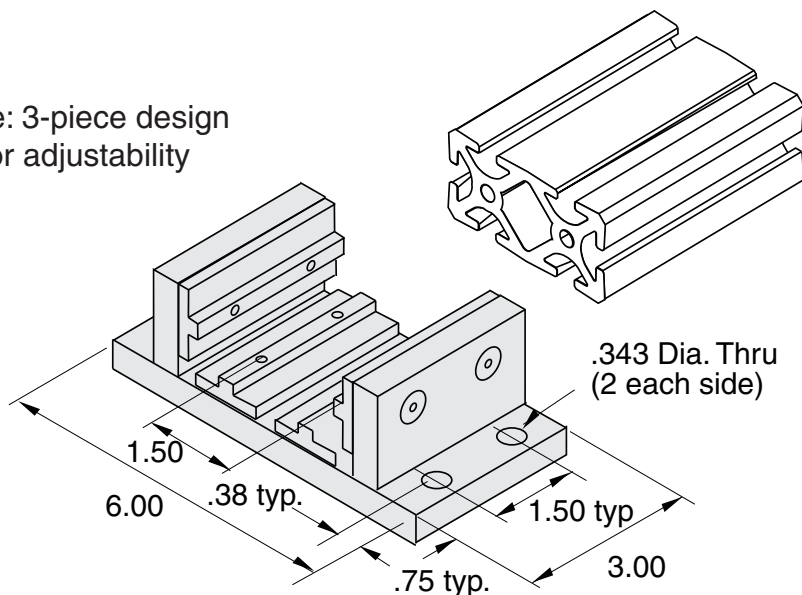

Recommended  
Hardware

- (4) EF-12-.875 BHCS
- (4) EF-55 T-nut

Bearing Material - DELRIN  
Plate Material - Aluminum (Clear Anodized)

**5/16" SLOTS**

# Single Mount Linear Bearing with Locking Handle



**EB-94LH**

**5/16" SLOTS**

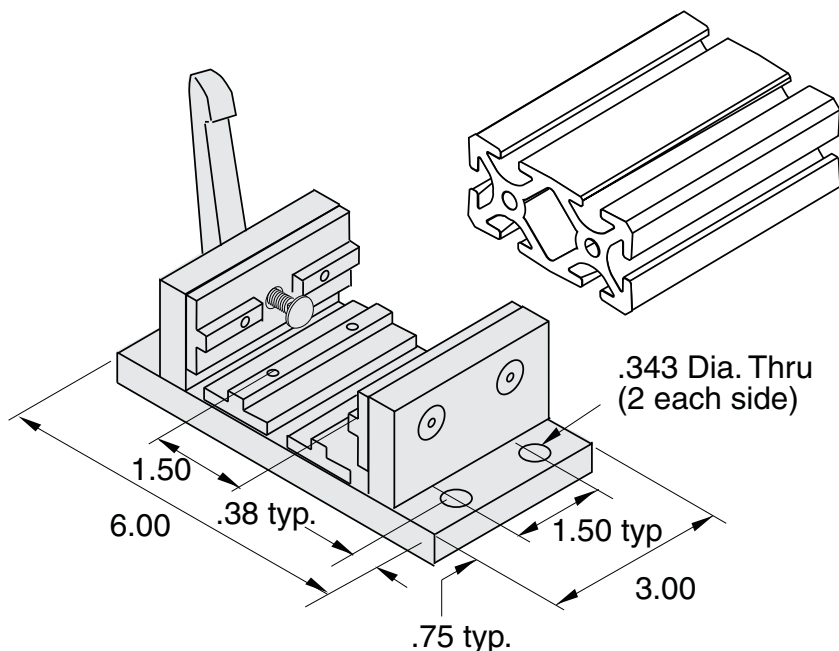
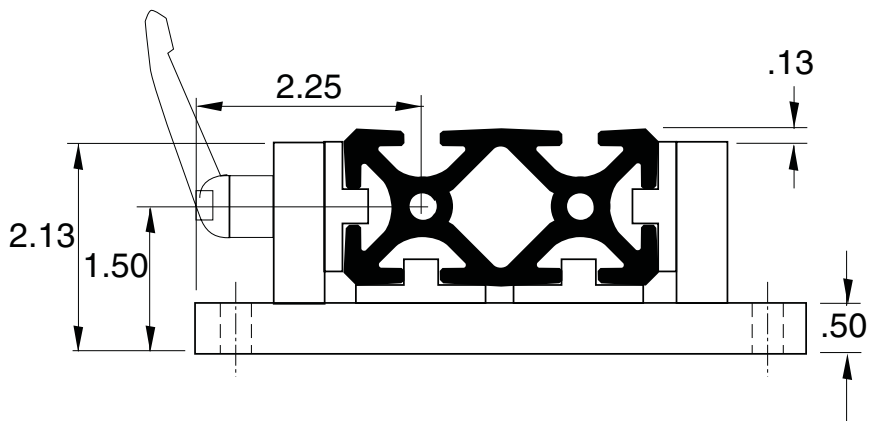

Recommended  
Hardware

(4) EF-12-.875 BHCS

(4) EF-55 T-nut

Bearing Material - DELRIN

Plate Material - Aluminum (Clear Anodized)

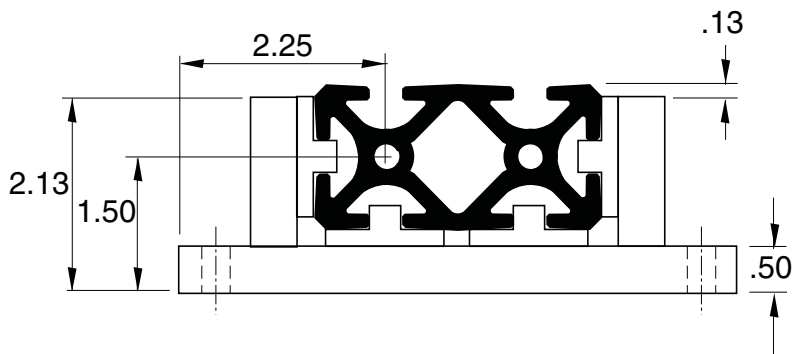

Note: 3-piece design  
for adjustability

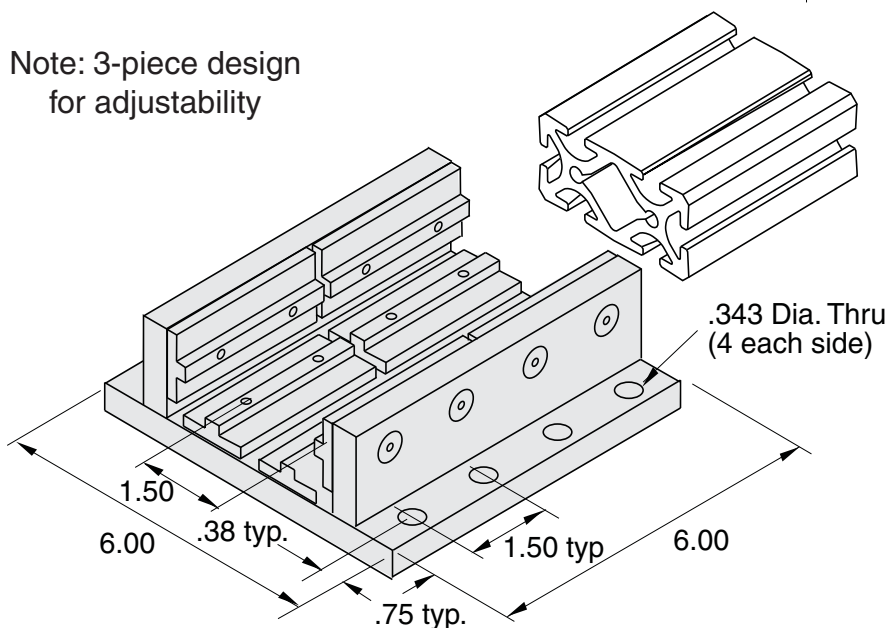

Recommended  
Hardware  
(8) EF-12-.875 BHCS  
(8) EF-55 T-nut

Bearing Material - DELRIN  
Plate Material - Aluminum (Clear Anodized)

5/16" SLOTS



# Double Mount Linear Bearing with Locking Handle



**EB-95LH**

**5/16" SLOTS**

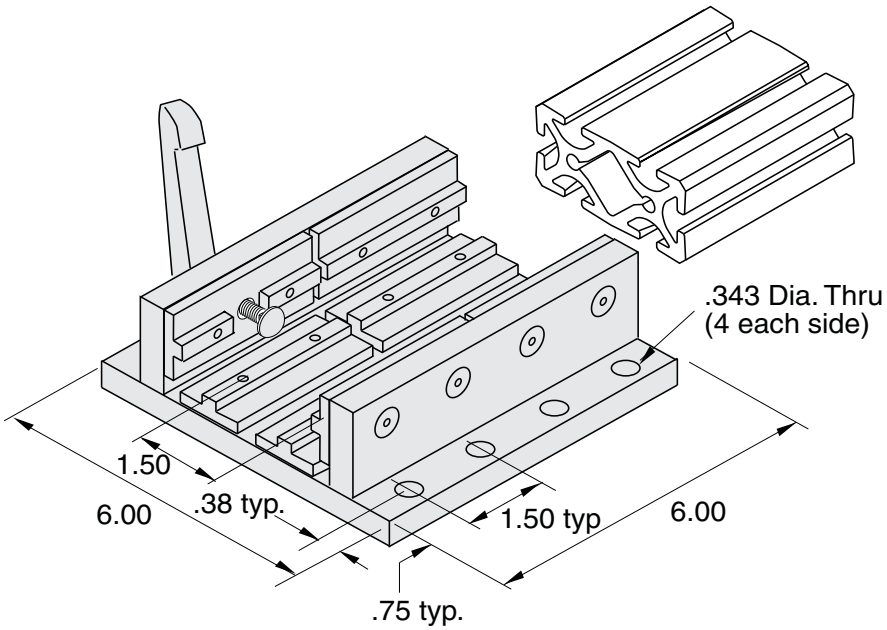
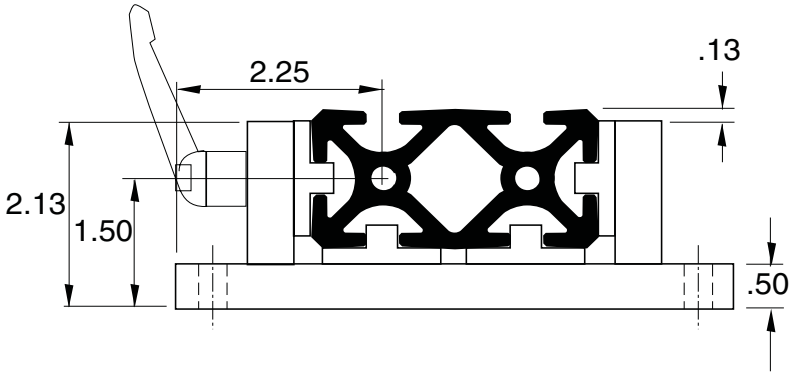

Recommended  
Hardware

- (8) EF-12-.875 BHCS
- (8) EF-55 T-nut

Bearing Material - DELRIN  
Plate Material - Aluminum (Clear Anodized)

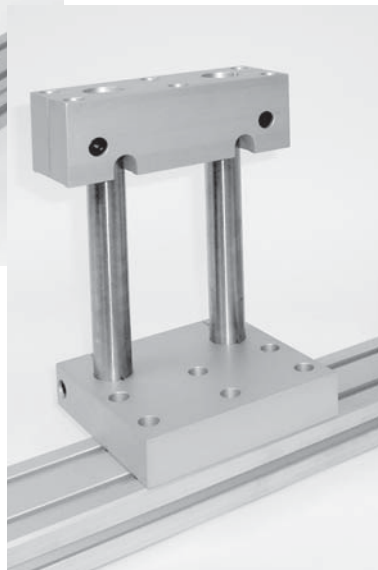
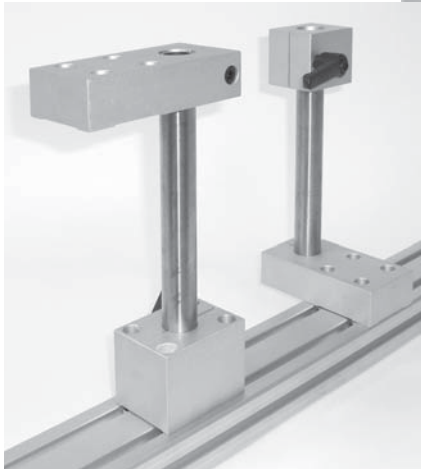
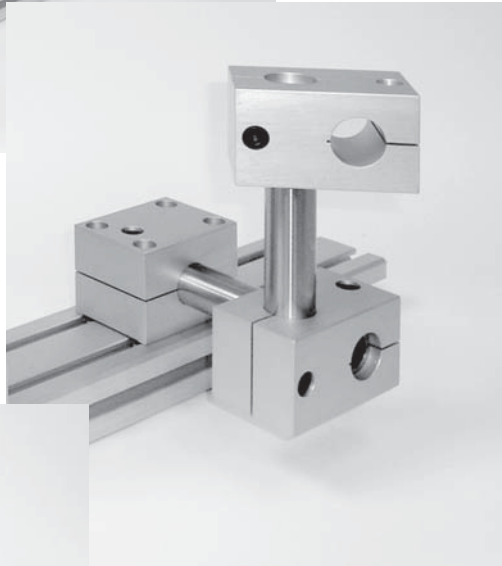
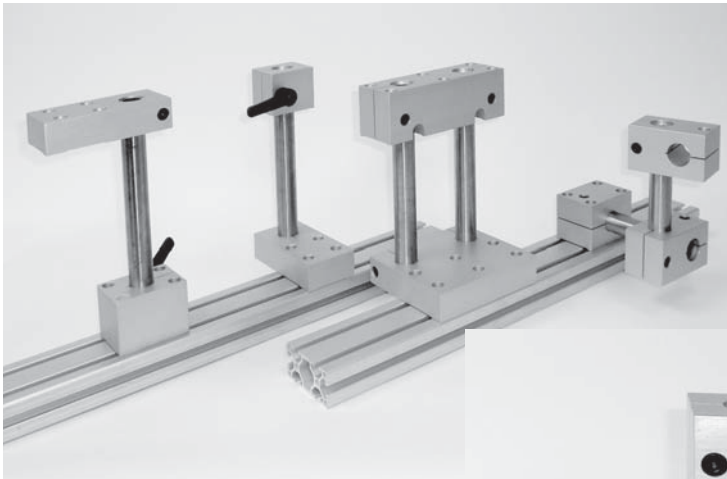

**5/16" SLOTS**

# Single Shaft Base



<b>EB-200</b>	<b>with locking handle</b>
<b>EB-201</b>	<b>with locking 5/16 SHCS</b>

5/16" SLOTS

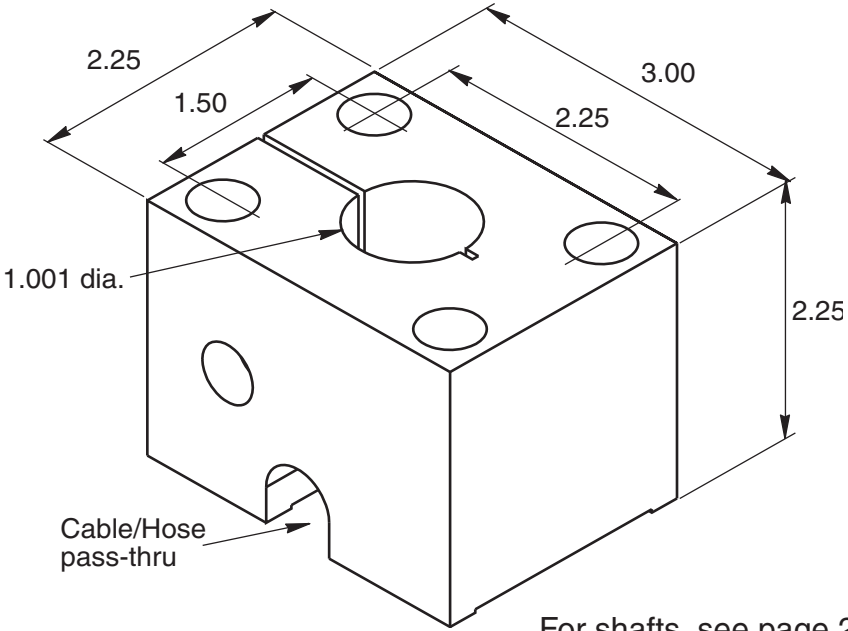

For shafts, see page 275.

**EX-2, EX-67,  
EX-3, EX-37**

Recommended  
Hardware  
(4) EF-11-1.75 SHCS  
(4) EF-55 T-nut

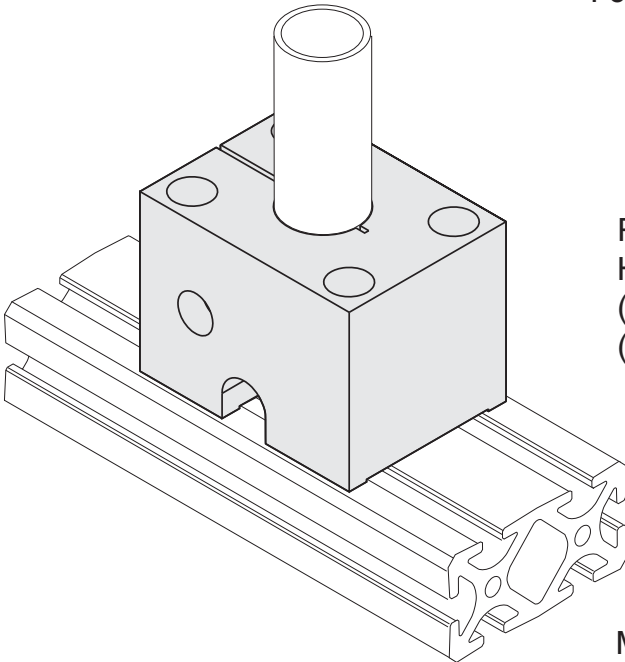

Material - Aluminum  
Finish - Clear Anodize

with locking handle	<b>EB-202</b>
with locking 5/16 SHCS	<b>EB-203</b>

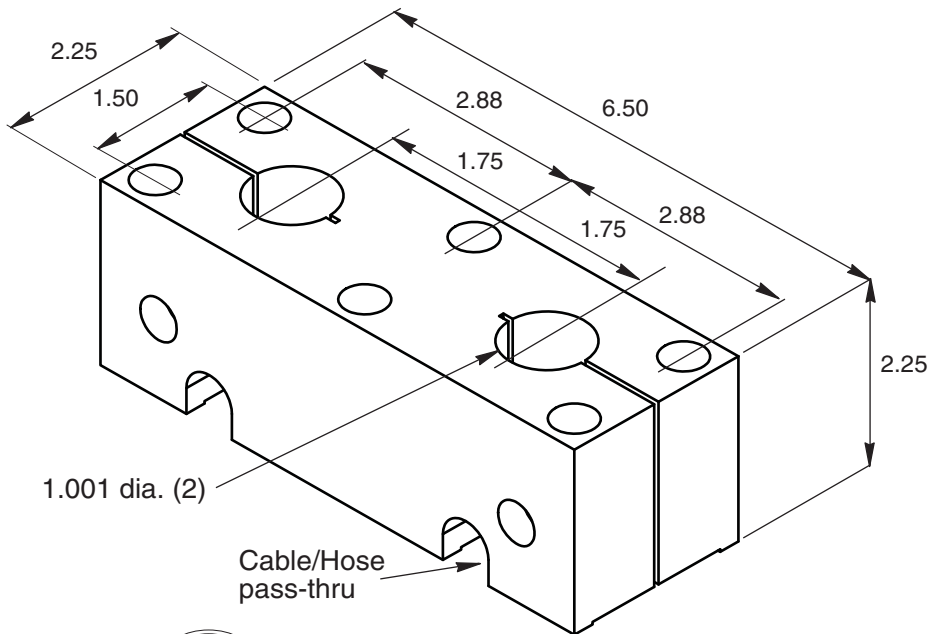

**5/16" SLOTS**

For shafts, see page 275.

**EX-2, EX-67,  
EX-3, EX-37**

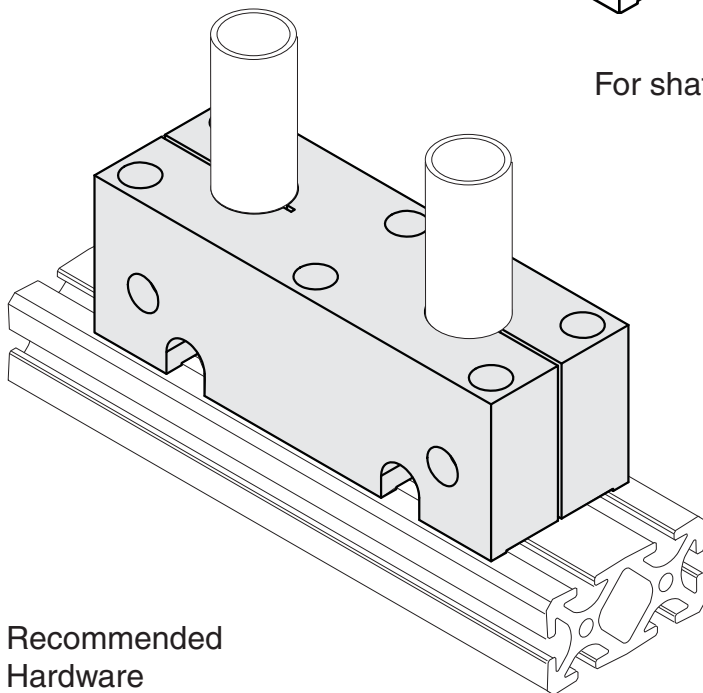

Recommended  
Hardware  
(6) EF-11-1.75 SHCS  
(6) EF-55 T-nut

Material - Aluminum  
Finish - Clear Anodize

# Single Shaft Mounting Plate



<b>EB-204</b>	<b>with locking handle</b>
<b>EB-205</b>	<b>with locking 5/16 SHCS</b>

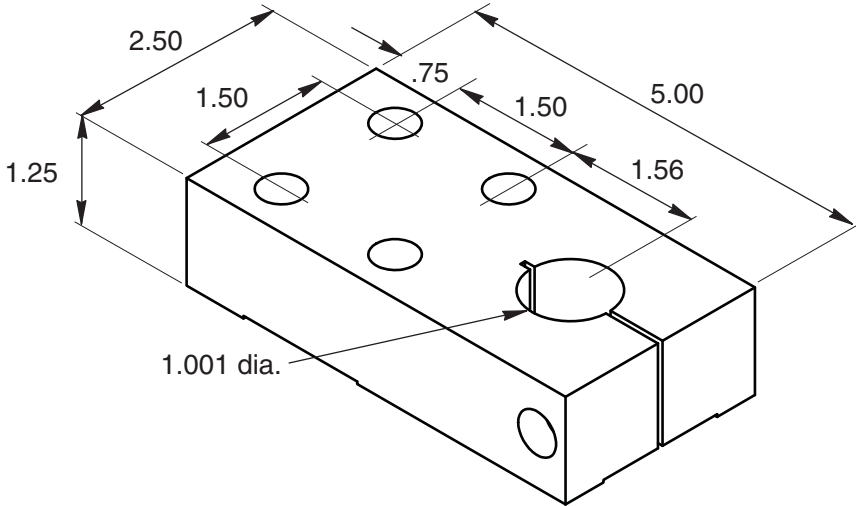

For shafts, see page 275.

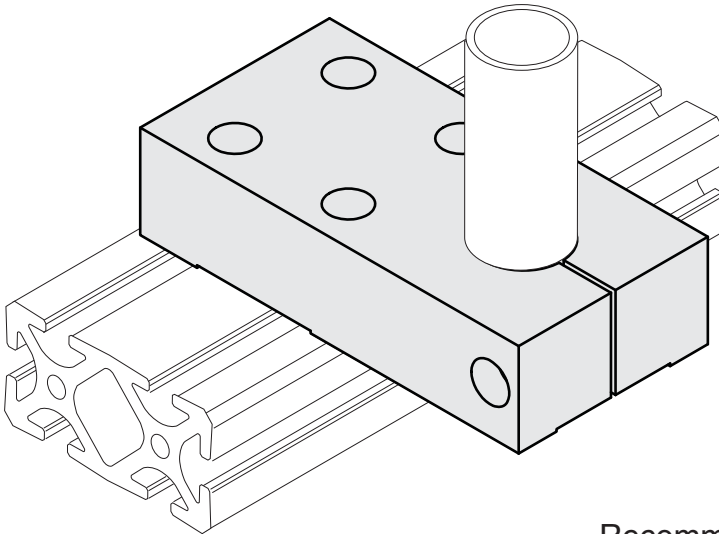

**EX-2, EX-67,  
EX-3, EX-37**

Material - Aluminum  
Finish - Clear Anodize

Recommended  
Hardware  
(4) EF-11-1.0 SHCS  
(4) EF-55 T-nut

**with locking handle**  
**with locking 5/16 SHCS**

**EB-206**

**EB-207**

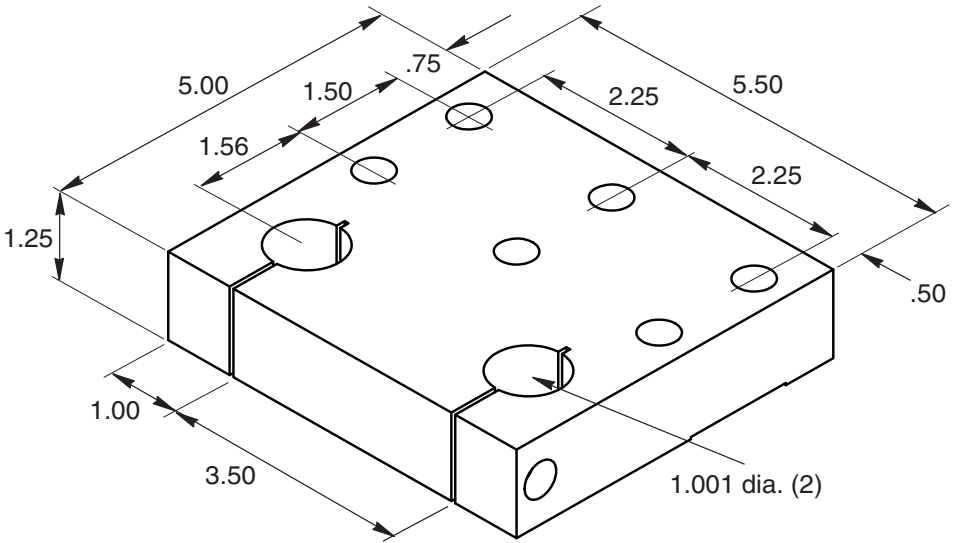

**5/16" SLOTS**

For shafts, see page 275.

**EX-2, EX-67,  
EX-3, EX-37**

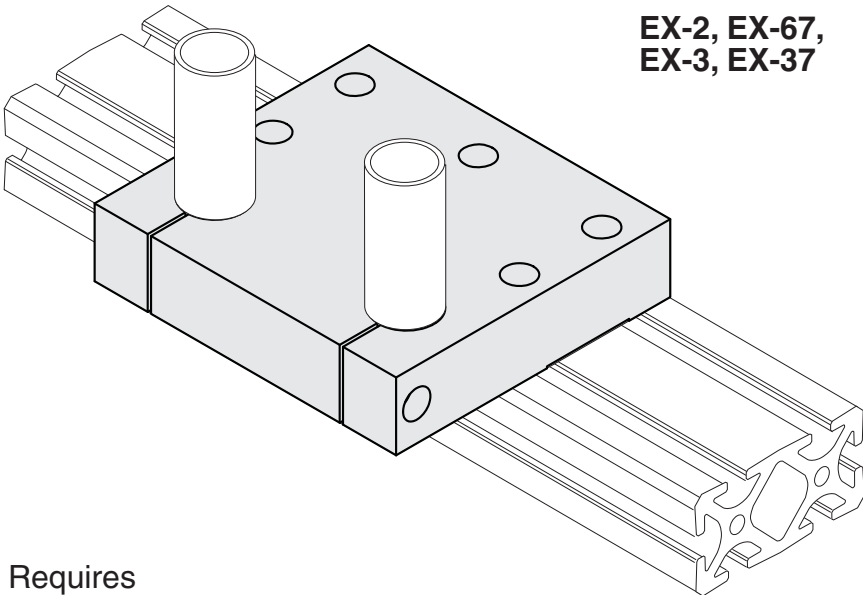

Requires  
(6) EF-11-1.0 SHCS  
(6) EF-55 T-nut

Material - Aluminum  
Finish - Clear Anodize

# Cross Clamp



<b>EB-208</b>	<b>with locking handle</b>
<b>EB-209</b>	<b>with locking 5/16 SHCS</b>

5/16" SLOTS

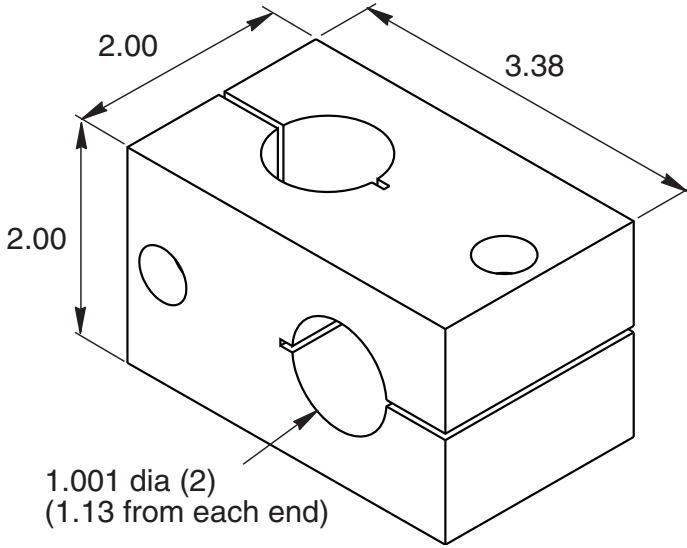

For shafts, see page 275.

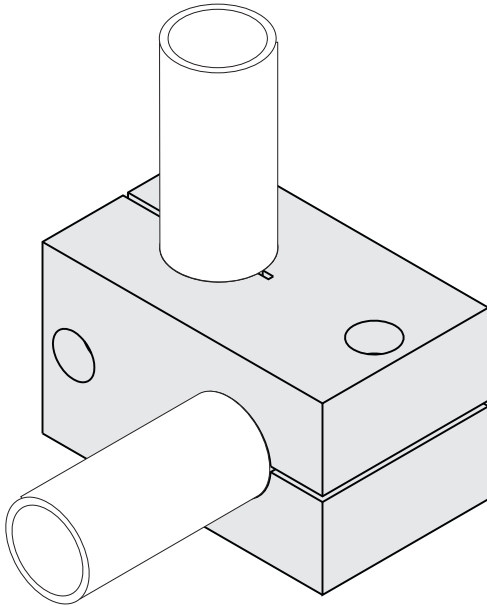

Material - Aluminum  
Finish - Clear Anodize

with locking handle	<b>EB-210</b>
with locking 5/16 SHCS	<b>EB-211</b>

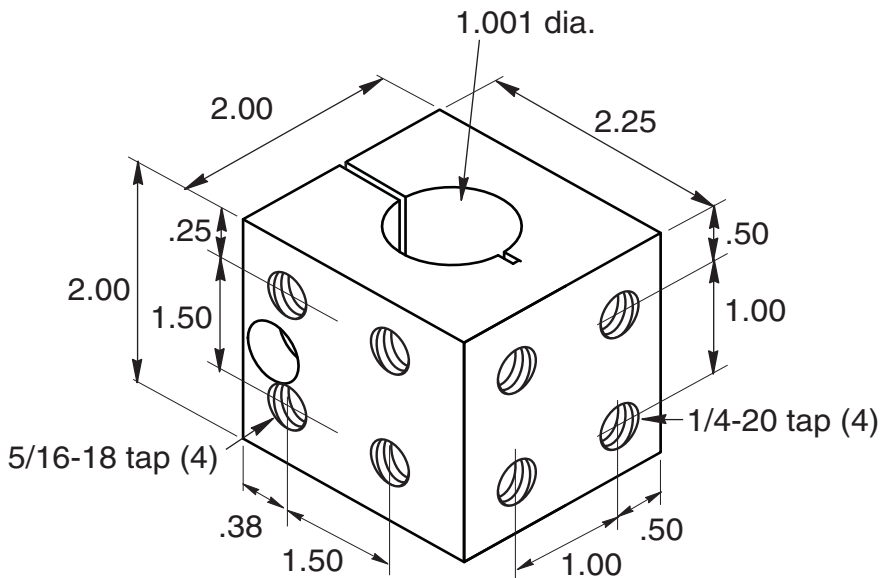

**5/16" SLOTS**

For shafts, see page 275.

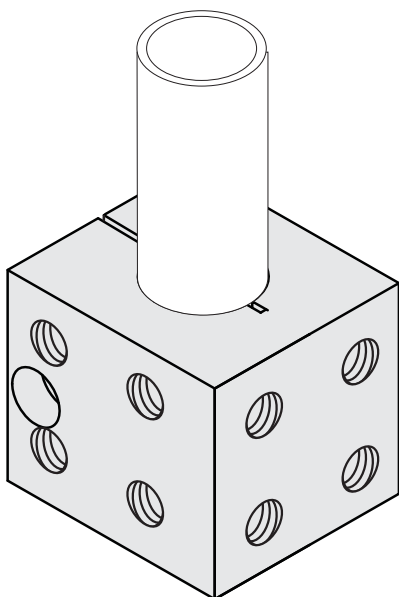

Material - Aluminum  
Finish - Clear Anodize



# Double Shaft Mounting Block



<b>EB-212</b>	with locking handle
<b>EB-213</b>	with locking 5/16 SHCS

5/16" SLOTS

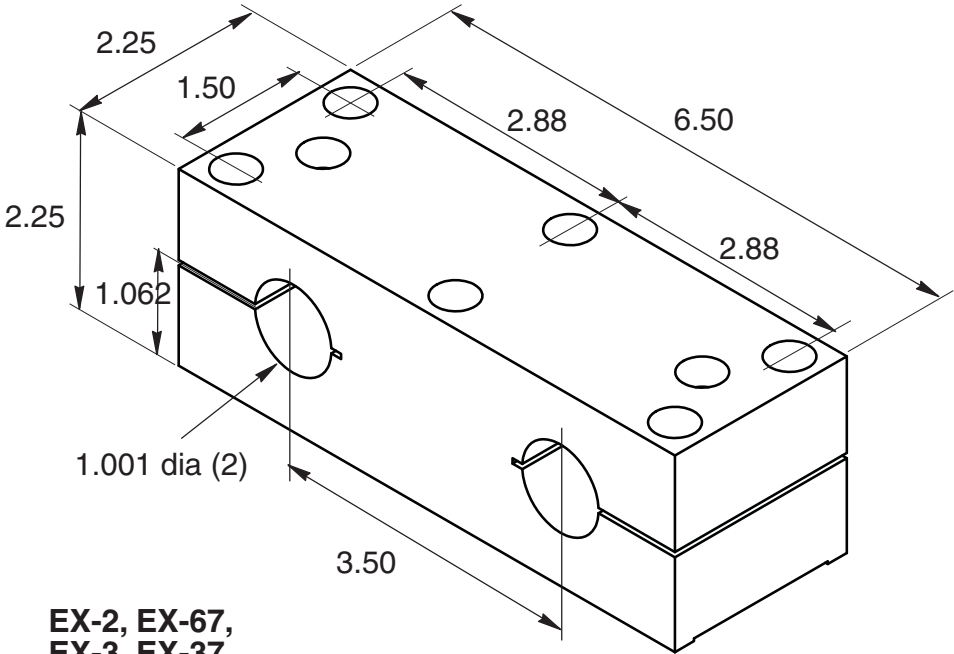

EX-2, EX-67,  
EX-3, EX-37

For shafts, see page 275.

Requires  
(6) EF-11-1.25 SHCS  
(6) EF-55 T-nut

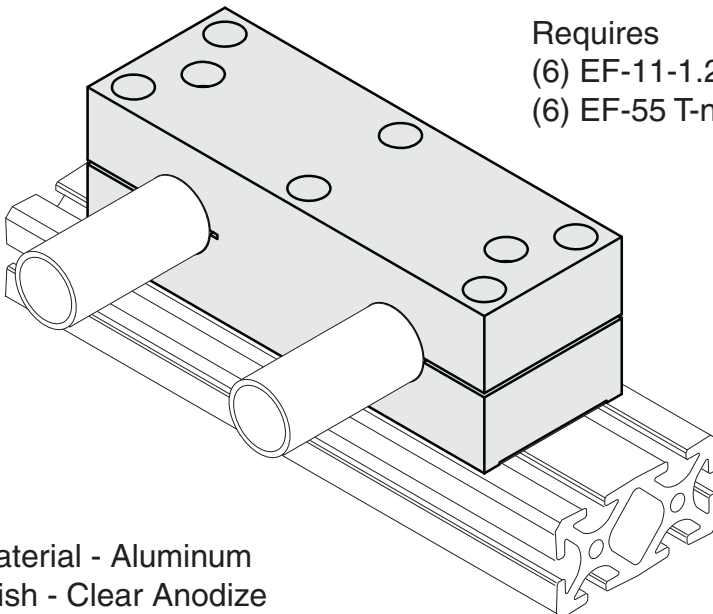

Material - Aluminum  
Finish - Clear Anodize

with locking handle  
with locking 5/16 SHCS

**EB-214**

**EB-215**

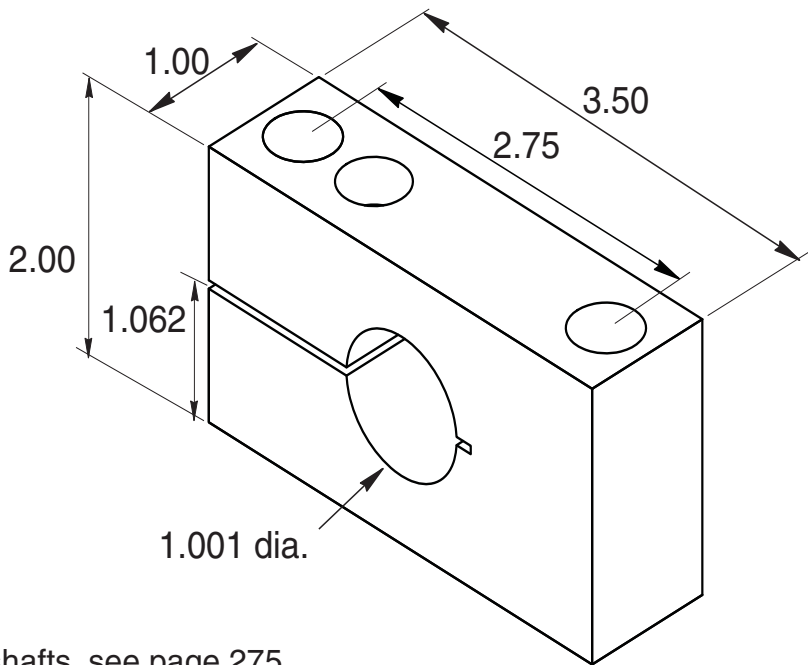

**5/16" SLOTS**

For shafts, see page 275.

**EX-2, EX-67,  
EX-3, EX-37**

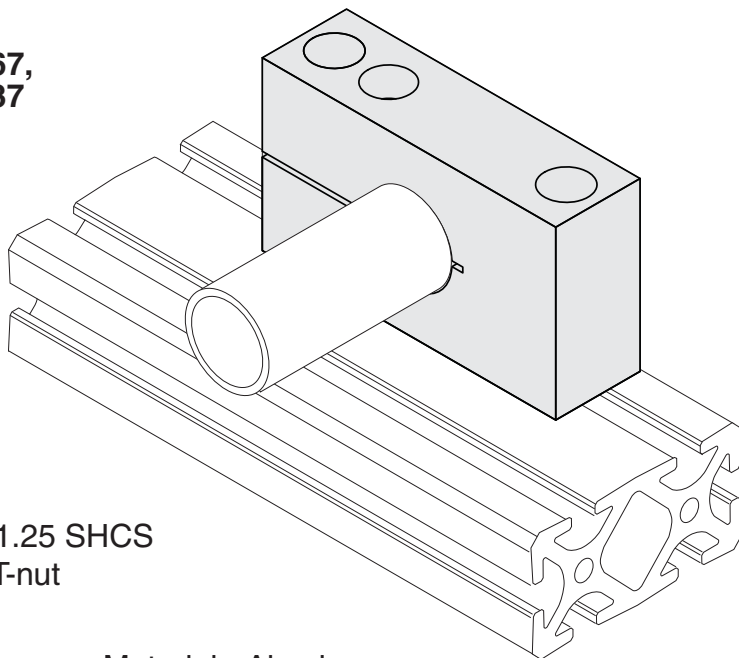

Requires

- (2) EF-11-1.25 SHCS
- (2) EF-55 T-nut

Material - Aluminum  
Finish - Clear Anodize

# Single Horizontal Base



<b>EB-216</b>	<b>with locking handle</b>
<b>EB-217</b>	<b>with locking 5/16 SHCS</b>

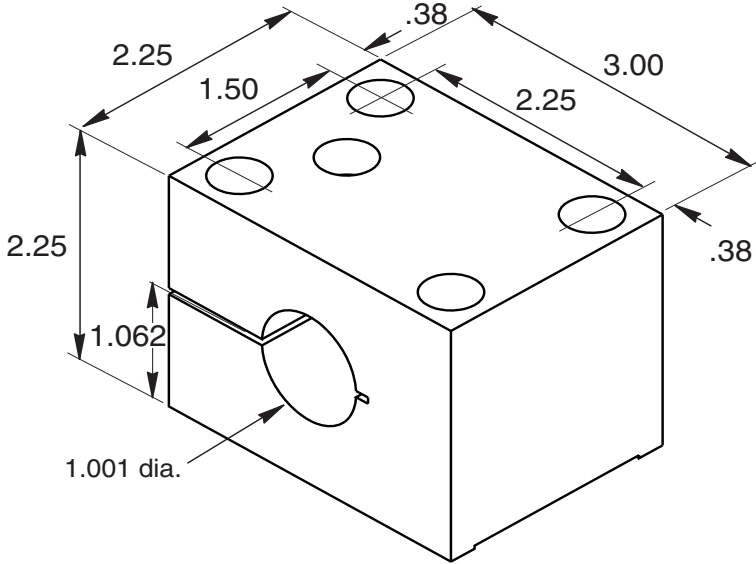

5/16" SLOTS

For shafts, see page 275.

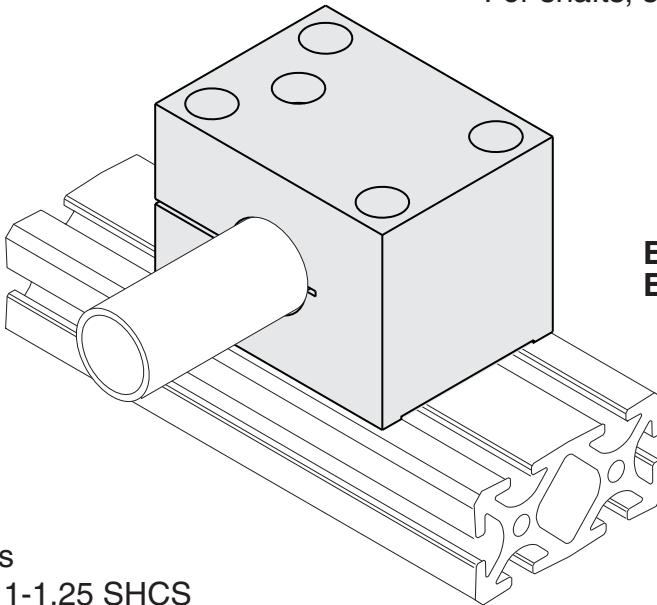

**EX-2, EX-67,  
EX-3, EX-37**

Requires

- (4) EF-11-1.25 SHCS
- (4) EF-55 T-nut

Material - Aluminum  
Finish - Clear Anodize

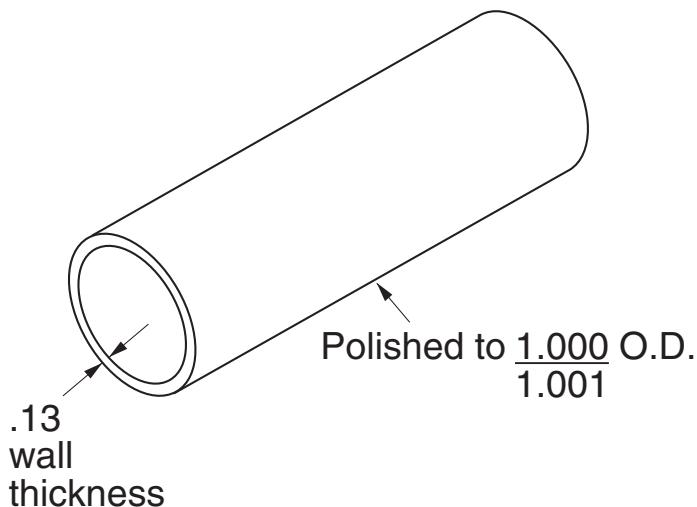
**EB-218****EB-219****5/16" SLOTS**

**EB-218** Anodized Aluminum  
Stock Length = 71"

**EB-219** Ground and Polished Steel (DOM)  
Stock Length = 71"

Note: For any length other than stock length for all of the above, add EM-1 cutting charge

# Conveyor Roller Mounting Block



<b>EF-150</b>
<b>EF-151</b>

**5/16" profiles**

**1/4" profiles**

**5/16" SLOTS**

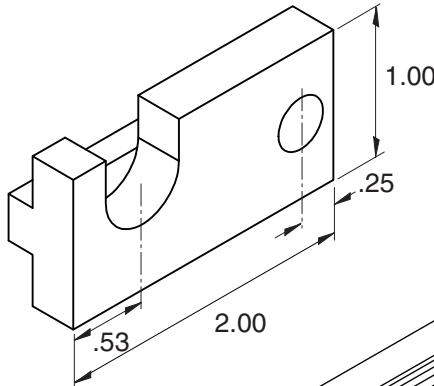

Axle size up to  
7/16" hex or 1/2" round  
Fasteners Included

Rollers can be put in or taken  
out individually without taking  
conveyor apart

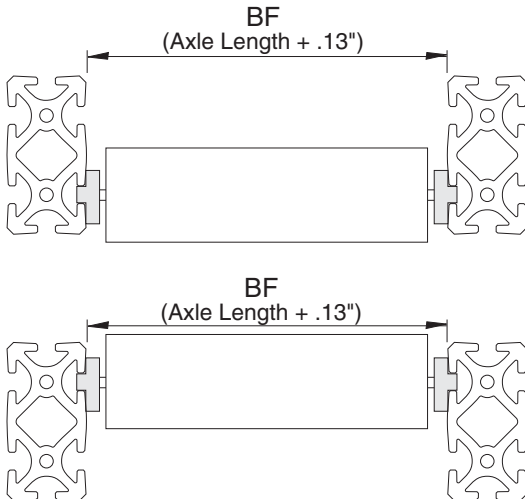
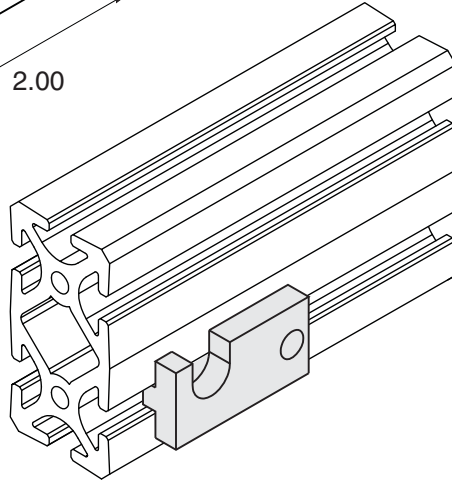

Roller Part no.	BF (Length between frame) Inches
<b>EF-161</b>	14.375
<b>EF-162</b>	20.375
<b>EF-163</b>	26.375
<b>EF-166</b>	14.375
<b>EF-167</b>	20.375
<b>EF-168</b>	26.375

Note: See page 277 for rollers.

Material - Aluminum  
Finish - Clear Anodize

**EF-160**

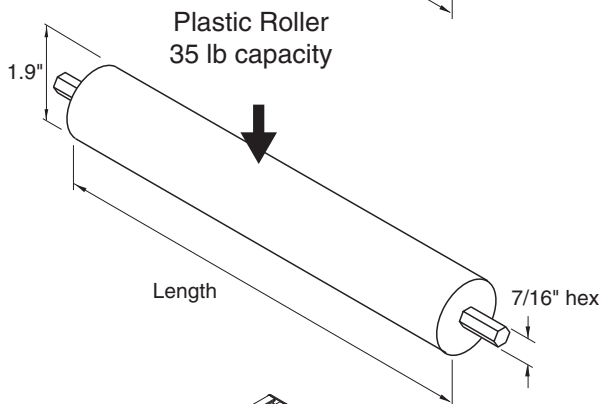
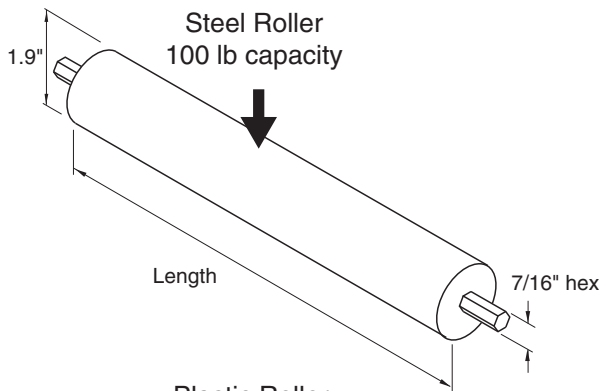

**Steel Rollers  
(Mild-uncoated)**

<b>EF-161</b>	12.75" long
<b>EF-162</b>	18.75" long
<b>EF-163</b>	24.75" long

**Plastic Rollers  
(PVC)**

<b>EF-166</b>	12.75" long
<b>EF-167</b>	18.75" long
<b>EF-168</b>	24.75" long

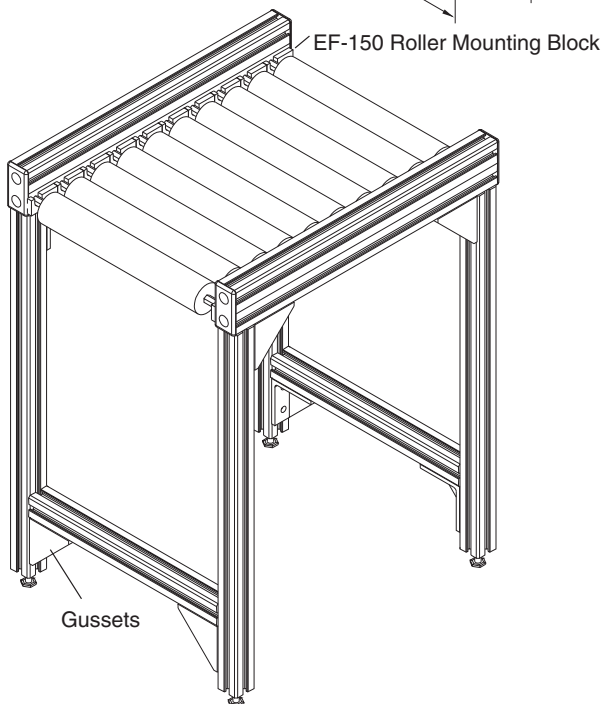

Note: Other roller types available, consult factory.

**5/16" SLOTS**

# Socket Head Cap Screw



## EF-11

Fractional  
EF-11 (5/16-18 thd)

- L - inch
- .5
  - .63
  - .75
  - .875
  - 1.0
  - 1.25
  - 1.5
  - 1.75
  - 2.0

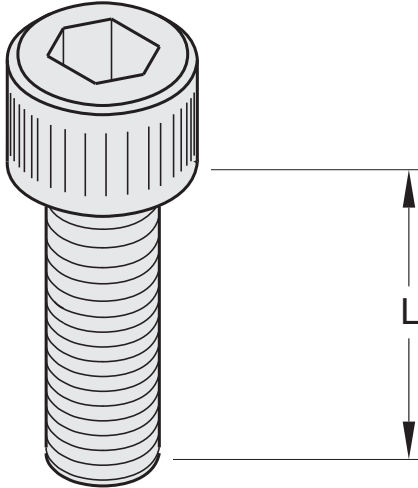

Metric  
EF-11M (m8 thd)

- L - mm
- 12
  - 16
  - 20
  - 25
  - 30
  - 35

Material - Steel  
Finish - Black Oxide Coated

5/16" SLOTS

## EF-11SS Stainless Steel

- L-inch
- EF-11SS-.5
  - EF-11SS-.63
  - EF-11SS-.75
  - EF-11SS-1.0
  - EF-11SS-1.25

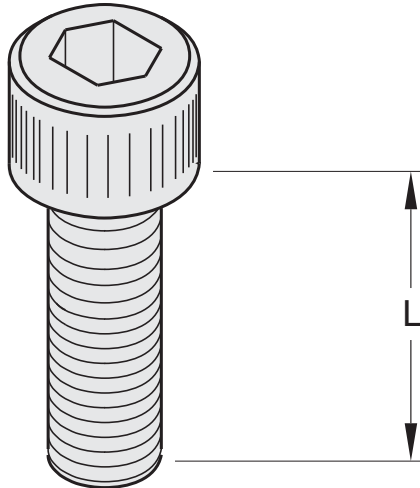

Material - Stainless Steel

Fractional  
(5/16" - 18 thd) L = inch

**EF-11K-.50**  
**EF-11K-.63**  
**EF-11K-.75**  
**EF-11K-.875**  
**EF-11K-1.00**  
**EF-11K-1.25**  
**EF-11K-1.50**

Metric  
(M8 x 1.25 thd) L = mm

**EF-11MK-12**  
**EF-11MK-16**  
**EF-11MK-20**  
**EF-11MK-25**  
**EF-11MK-30**  
**EF-11MK-35**

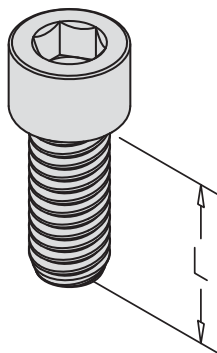

Material - Steel  
Finish - Bright Zinc Plated

**5/16" SLOTS****Button Head** **EF-12K**

Fractional  
(5/16" - 18 thd) L = inch

**EF-12K-.50**  
**EF-12K-.63**  
**EF-12K-.75**  
**EF-12K-.875**  
**EF-12K-1.00**  
**EF-12K-1.25**  
**EF-12K-1.50**

Metric  
(M8 x 1.25 thd) L = mm

**EF-12MK-12**  
**EF-12MK-16**  
**EF-12MK-20**  
**EF-12MK-25**  
**EF-12MK-30**  
**EF-12MK-35**

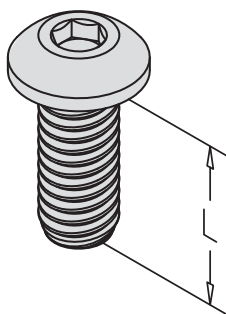

Material - Steel  
Finish - Bright Zinc Plated



# Button Head Cap Screw



## EF-12

Fractional  
EF-12  
(5/16-18 thd)

- L - inch
- .5
  - .63
  - .75
  - .875
  - 1.0
  - 1.25
  - 1.5

Metric  
EF-12M  
(m8 thd)

- L - mm
- 12
  - 16
  - 20
  - 25
  - 30

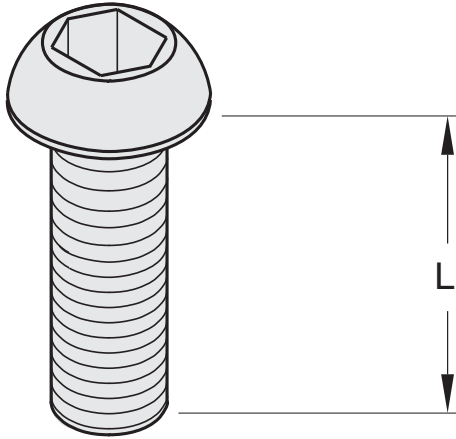

Material - Steel  
Finish - Black Oxide Coated

5/16" SLOTS

## EF-12SS

### Stainless Steel Button Head Cap Screw

- L-inch
- EF-12SS-.5
  - EF-12SS-.63
  - EF-12SS-.75
  - EF-12SS-1.0
  - EF-12SS-1.25

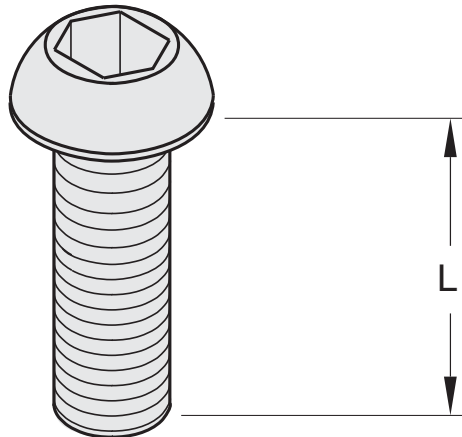

Material - Stainless Steel

**Flat Head Socket Cap Screws**

**5/16-18 thd.**

**EF-156**

**1/4-20 thd.**

**EF-157**

**#10-32 thd.**

**EF-158**

**Steel**

(5/16" - 18 thd) L = inch

**EF-156-.50**

**EF-156-.63**

**EF-156-.75**

**EF-156-.88**

**EF-156-1.0**

**EF-156-1.25**

(1/4" - 20 thd) L = inch

**EF-157-.50**

**EF-157-.63**

**EF-157-.75**

**EF-157-1.0**

(#10-32 thd) L = inch

**EF-158-.50**

**EF-158-.63**

**Stainless Steel**

(5/16" - 18 thd) L = inch

**EF-156SS-.50**

**EF-156SS-.63**

**EF-156SS-.75**

(1/4" - 20 thd) L = inch

**EF-157SS-.50**

**EF-157SS-.63**

(#10-32 thd) L = inch

**EF-158SS-.50**

**EF-158SS-.63**

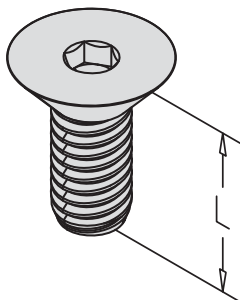

Material - Steel  
Finish - Black Oxide

Material - Stainless Steel

**Button Head Cap Screw (Flanged)**

**EF-12F**

**EF-12F (flanged)**

**(5/16-18 thd)**

**L - inch**

.5

.63

.75

1.0

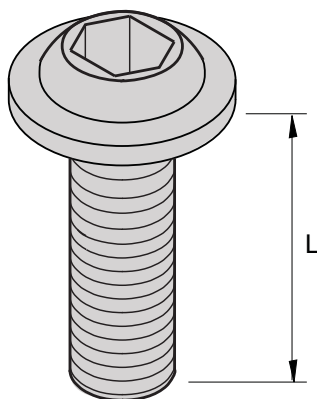

Material - Steel  
Finish - Black Oxide Coated

**5/16" SLOTS**

**EF-155**

**5/16" SLOTS**

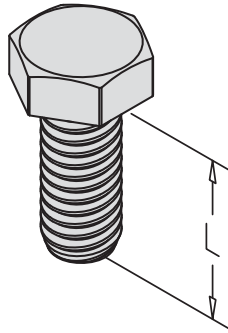

Fractional  
(5/16" - 18 thd) L = inch

- EF-155-.50**
- EF-155-.63**
- EF-155-.75**
- EF-155-.875**
- EF-155-1.00**
- EF-155-1.25**
- EF-155-1.50**

Material - Steel  
Finish - Bright Zinc Plated

Metric  
(M8 x 1.25 thd) L = mm

- EF-155M-12**
- EF-155M-16**
- EF-155M-20**
- EF-155M-25**
- EF-155M-30**

Material - Steel  
Finish - Yellow Zinc Plated

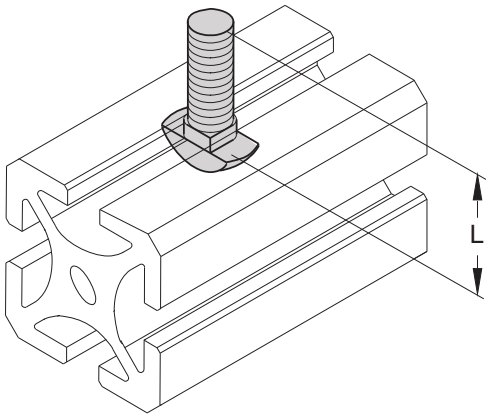

- L - inch**  
-.75  
-1.0  
-1.25  
-1.50

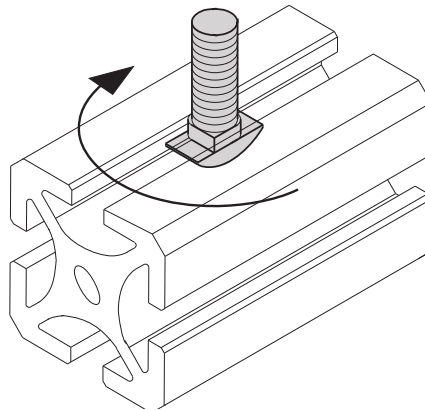

**5/16" SLOTS**

Material - Steel  
Finish - Zinc Plated

**EF-10**

**Fractional**  
**EF-10 (5/16-18 thd)**

**Metric**  
**EF-10M (m8 thd)**

**L - inch**

**L - mm**

.75

20

1.0

25

1.25

35

1.5

45

2.0

**5/16" SLOTS**

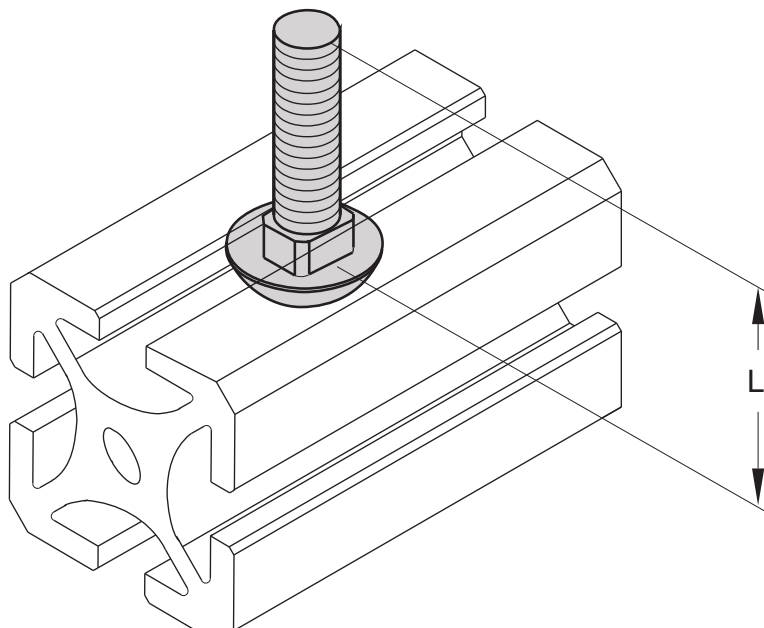

**Material - Steel**  
**Finish - Zinc Plated**

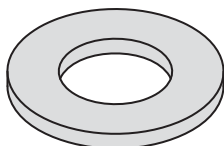

- EF-13A** Washer Hardened Steel Heavy Duty  
(Black Oxide) (use with M8 also)  
**EF-SS13A** Washer (Stainless Steel)  
**EF-13S** Washer (Zinc Plated)

Material - Steel



- EF-13B** Serrated Belleville  
(use with M8 also)

Material - Steel  
Finish - Black Oxide

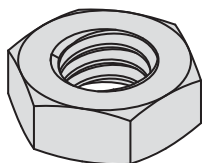

- EF-13C** 5/16-18 Hex Nut  
**EF-13CM** M8 Hex Nut

Material - Steel  
Finish - Zinc Plated

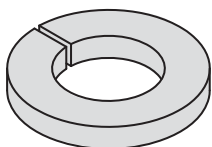

- EF-13L** Locking Washer

Material - Steel  
Finish - Zinc Plated

**EF-1**

**5/16" SLOTS**

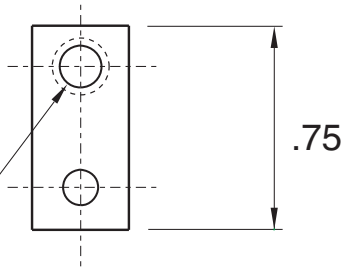
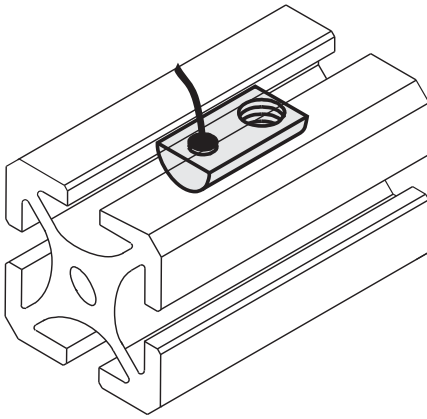

- EF-1** 5/16-18 thd
- EF-1A** 1/4-20 thd
- EF-1B** 10-32 thd
- EF-1C** m8 thd
- EF-1D** m6 thd
- EF-1E** 8-32 thd

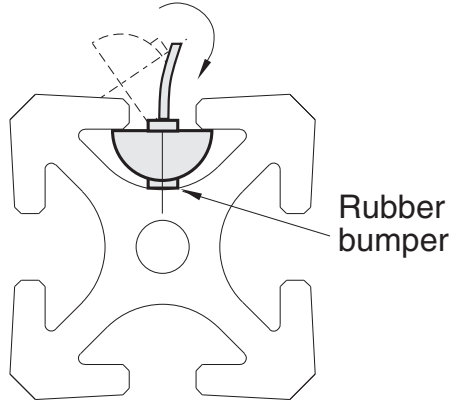

Material - Steel  
Finish - Zinc Plated

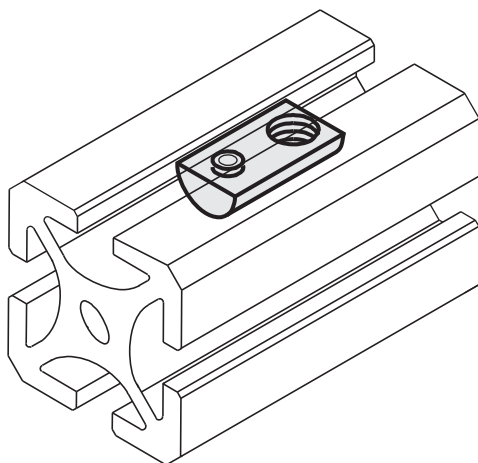

<b>EF-65</b>
<b>EF-66</b>
<b>EF-67</b>
<b>EF-68</b>
<b>EF-69</b>

**5/16" SLOTS**

- EF-65** 5/16-18 thd
- EF-66** 1/4-20 thd
- EF-67** 10-32 thd
- EF-68** m8 thd
- EF-69** m6 thd

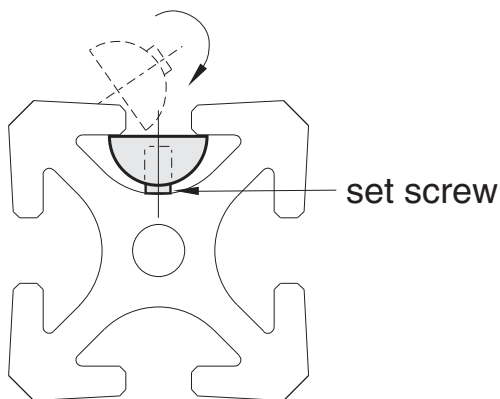
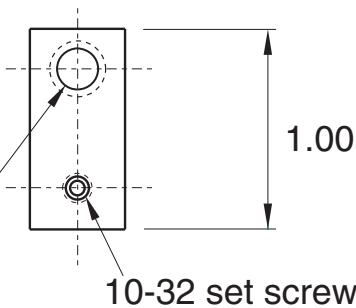

**Material - Steel**  
**Finish - Zinc Plated**



# Ball and Spring Pivot T-nut



<b>EF-91</b>
<b>EF-92</b>
<b>EF-93</b>
<b>EF-94</b>
<b>EF-95</b>

use with EX-1, EX-2, EX-26,  
EX-3, and EX-36 only

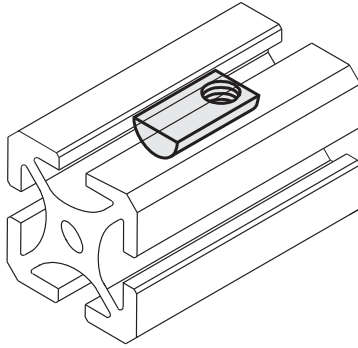

**5/16" SLOTS**

- EF-91** 5/16-18 thd
- EF-92** 1/4-20 thd
- EF-93** 10-32 thd
- EF-94** m8 thd
- EF-95** m6 thd

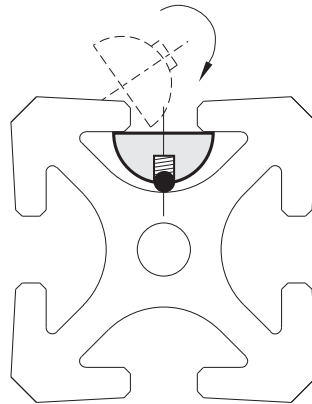
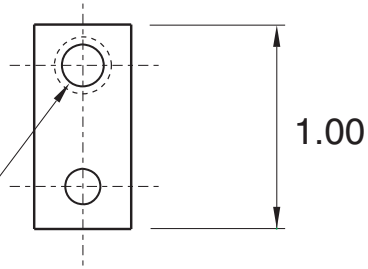

Material - Steel  
Finish - Zinc Plated

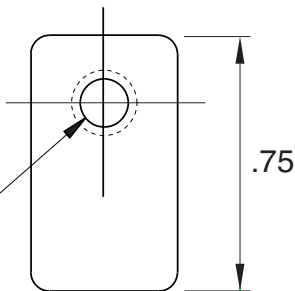
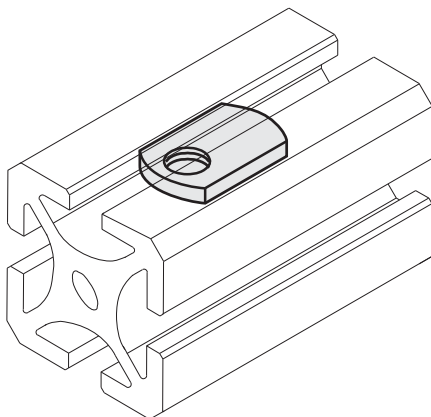

- EF-2** 5/16-18 thd
- EF-2A** 1/4-20 thd
- EF-2B** 10-32 thd
- EF-2C** m8 thd
- EF-2E** m6 thd
- EF-2H** 6-32 thd
- 11-217** 8-32 thd

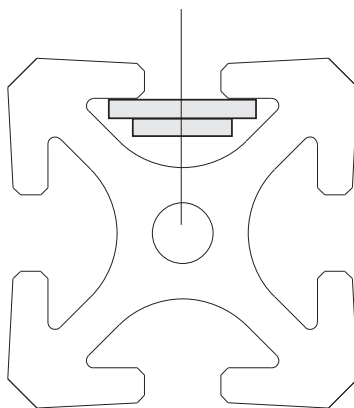

Material - Steel  
Finish - Zinc Plated

<b>EF-2ST</b>
<b>EF-2AST</b>
<b>EF-2CST</b>

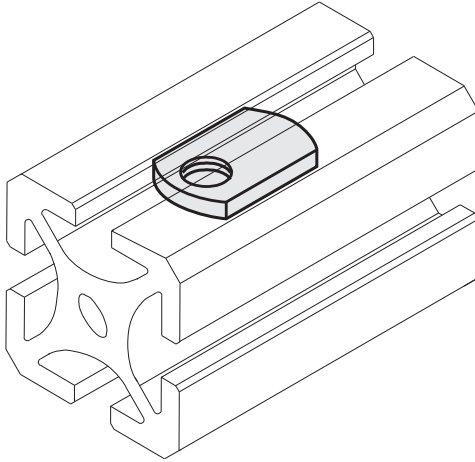

**5/16" SLOTS**

**EF-2ST  
EF-2AST  
EF-2CST**

5/16-18 thd  
1/4-20 thd  
m8 thd

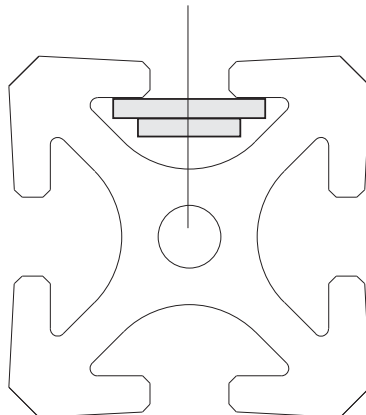
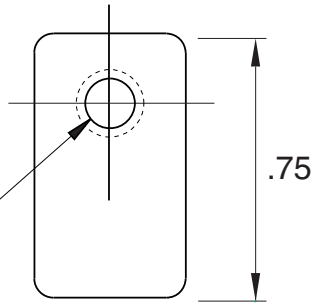

**EF-50**

**EF-51**

**EF-52**

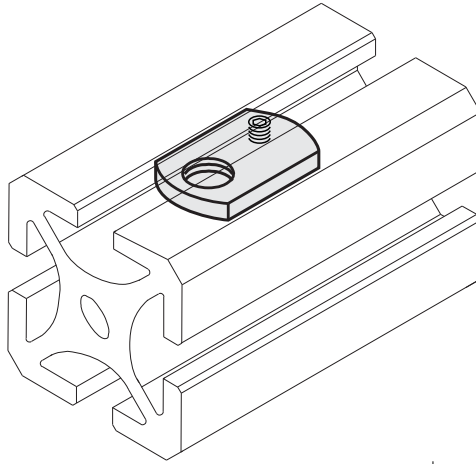

**5/16" SLOTS**

- EF-50** 5/16-18 thd
- EF-51** 1/4-20 thd
- EF-52** m8 thd

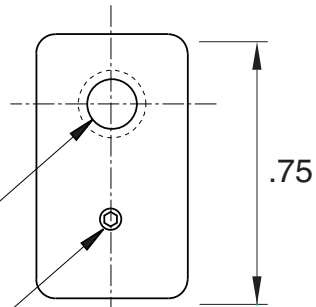

set screw  
(included)

Set screw holds  
T-nut in place

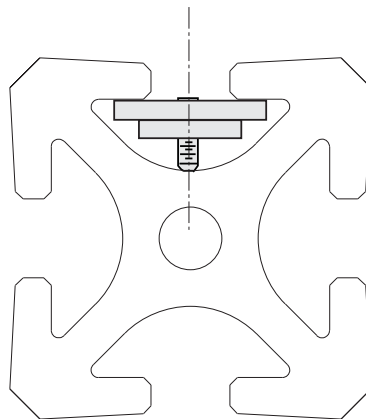

Material - Steel  
Finish - Zinc Plated

**EF-4**

**5/16" SLOTS**

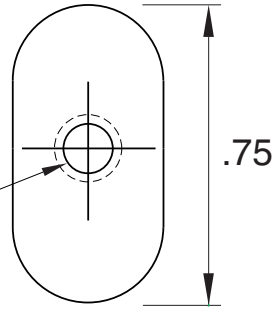
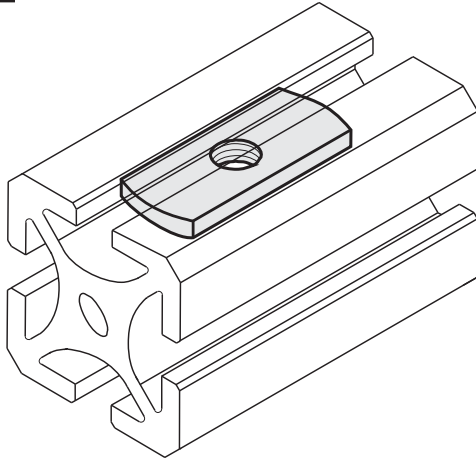

- EF-4** 5/16-18 thd
- EF-4A** 1/4-20 thd
- EF-4B** 10-32 thd
- EF-4C** m8 thd
- EF-4D** m6 thd
- 11-217** 8-32 thd
- 11-219** 6-32 thd

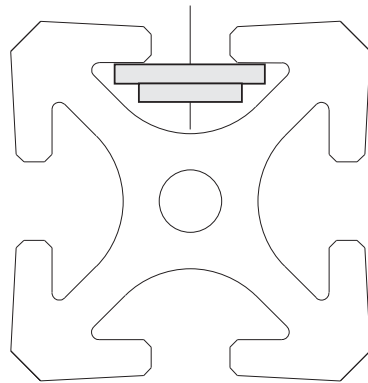

Material - Steel  
Finish - Zinc Plated

5/16-18 Thd

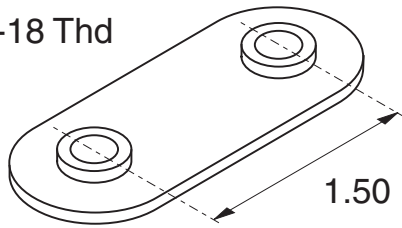

5/16" SLOTS

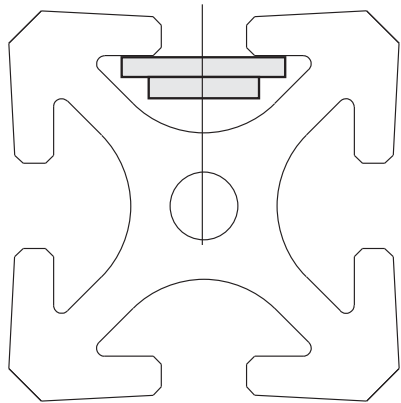
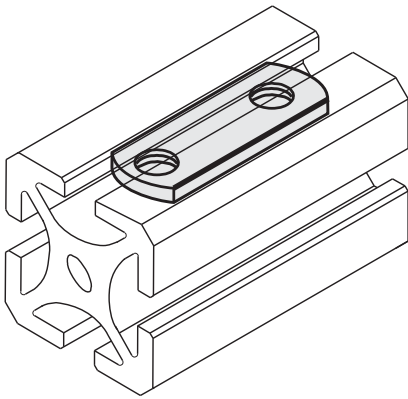

Material - Steel  
Finish - Zinc Plated

# Heavy Duty T-nut



<b>EF-55</b>	<b>.33 Slot Width</b>
<b>EF-56</b>	
<b>EF-57</b>	
<b>EF-58</b>	
<b>EF-59</b>	
<b>EF-83</b>	
<b>EF-84</b>	

5/16" SLOTS

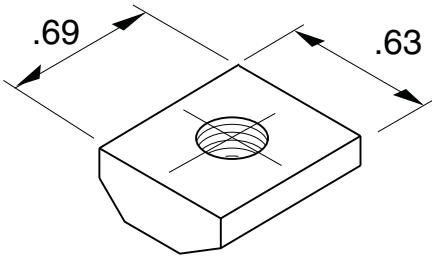

- EF-55** 5/16-18 thd
- EF-56** 1/4-20 thd
- EF-57** 10-32 thd
- EF-58** m8 thd
- EF-59** m6 thd
- EF-83** 8-32 thd
- EF-84** 6-32 thd

Note: Provides increased thread engagement

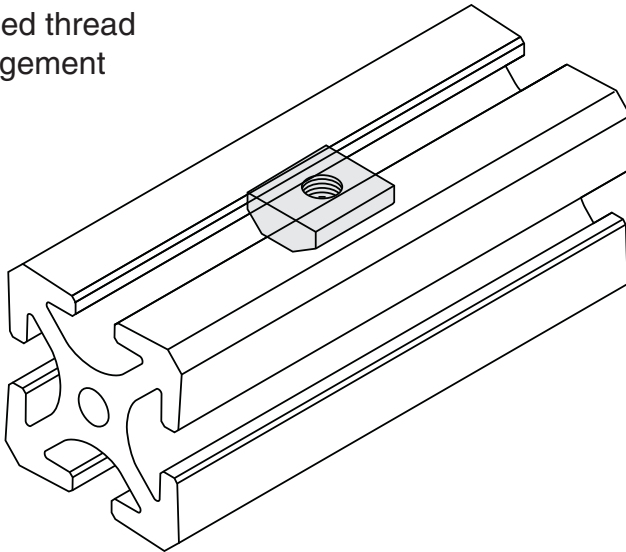

Material - Steel  
Finish - Zinc Plated

.33 Slot Width

**EF-53**

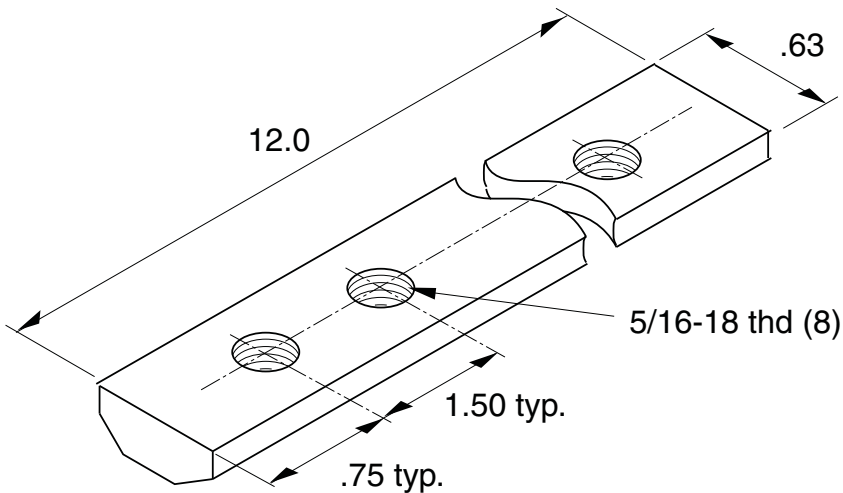

5/16" SLOTS

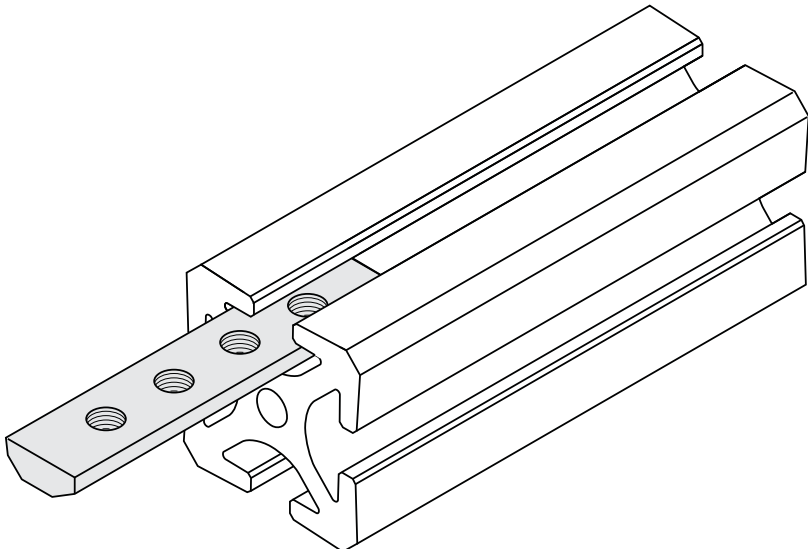

Special lengths can be provided on request

Material - Steel  
Finish - Zinc Plated



**EF-53B**

5/16" SLOTS

Standard Lengths  
6", 12" 24"

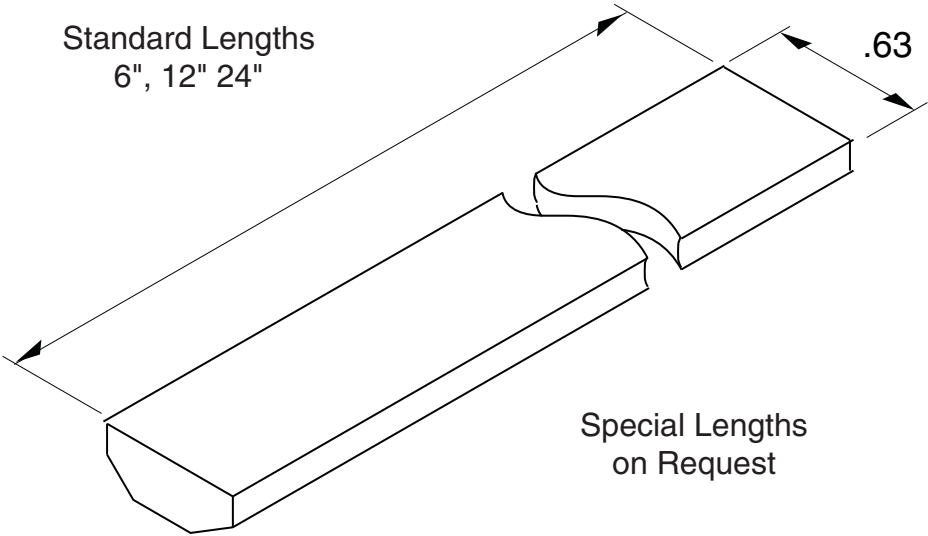

Special Lengths  
on Request

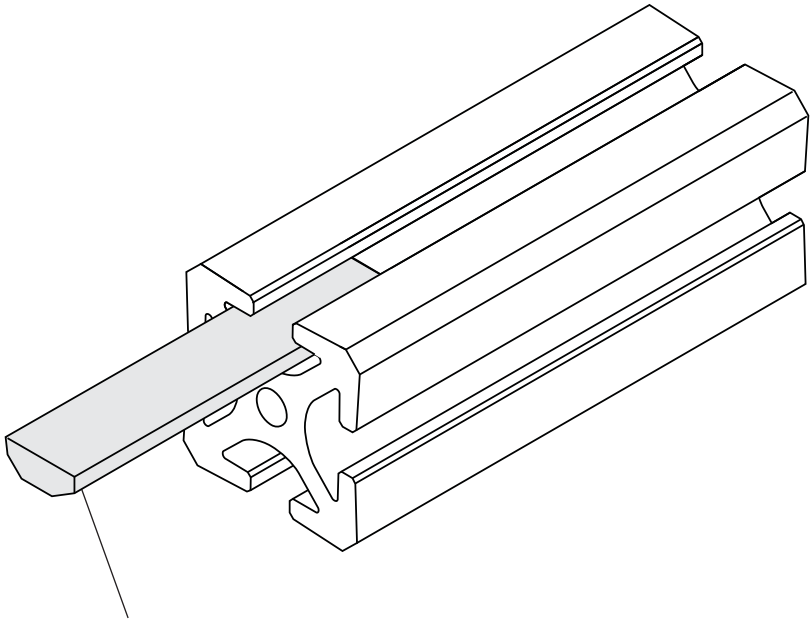

Note: Factory supplied tapped holes  
can be supplied per customer specification

Material - Steel  
Finish - Zinc Plated

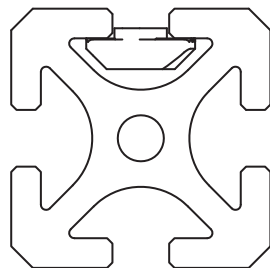
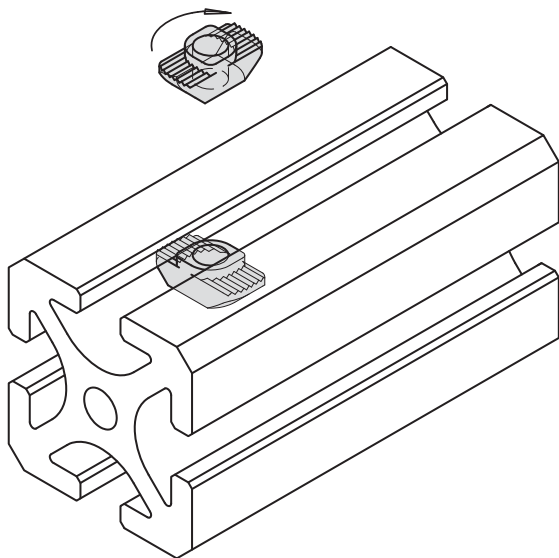

- EF-96** 1/4-20 thd.
- EF-97** 10-32 thd.
- EF-98** m6 thd.
- EF-99** m5 thd.

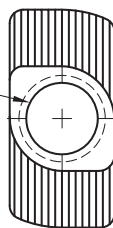

Use with 5/16" Slot Extrusions Only

Material - Steel  
Finish - Zinc Plated

**EF-14**

5/16" SLOTS

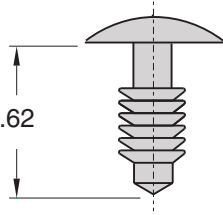

Note: Hole can be threaded for permanent installation

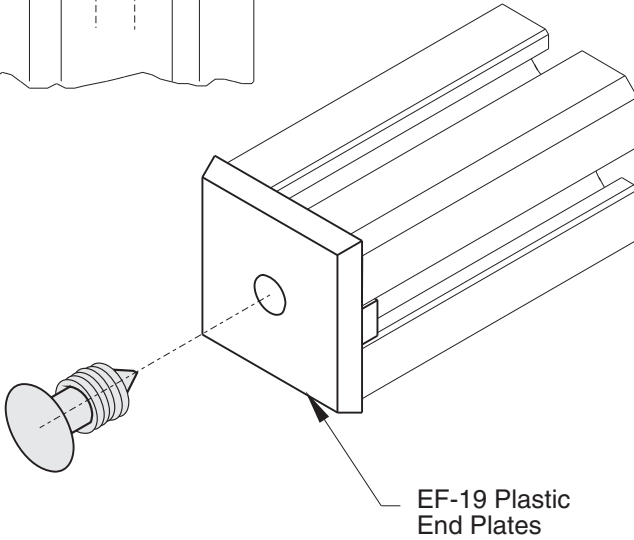
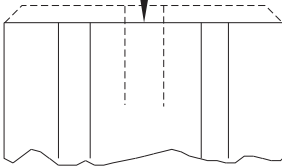

Material - Nylon

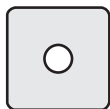
**EF-19-A**

use with EX-1,  
EX-6, EX-61,  
EX-63, EX-64,  
and EX-65

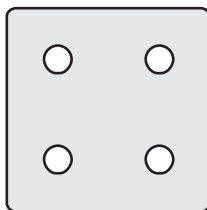
**EF-19-C**

use with EX-3,  
and EX-36

**EF-19-D**

use with EX-7

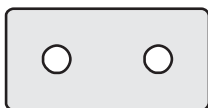
**EF-19-B**

use with EX-2,  
EX-67 and EX 68

**EF-19-E**

use with EX-52,  
and 11-251

**EF-19-F**

use with EX-8

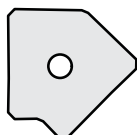
**EF-19-G**

use with EX-82

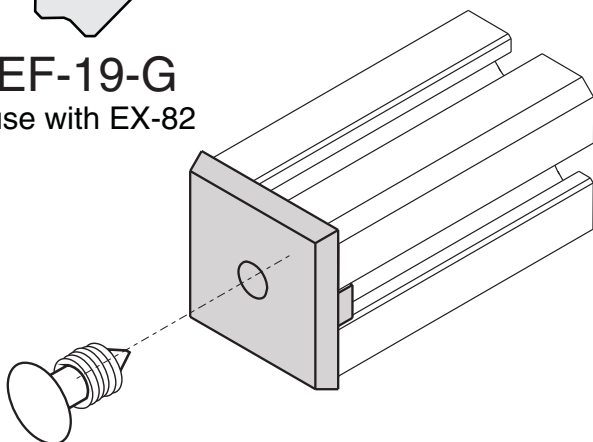

Push Lock Fasteners included with ALL end plates

Material - Black ABS Plastic

Note: for metal covers, consult the factory.

# Pneumatic Manifold End Plate and Gasket



## PM-2

### PM-2

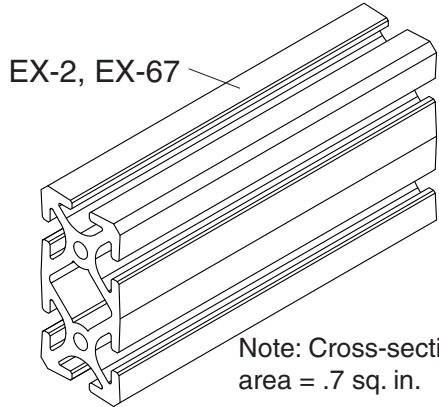

Drilled and C'bored  
for 5/16-18 SHCS (2)

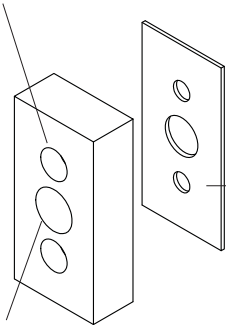

Note: Cross-sectional internal  
area = .7 sq. in.

Cork Gasket Included

3/8 NPT

### PM-2B

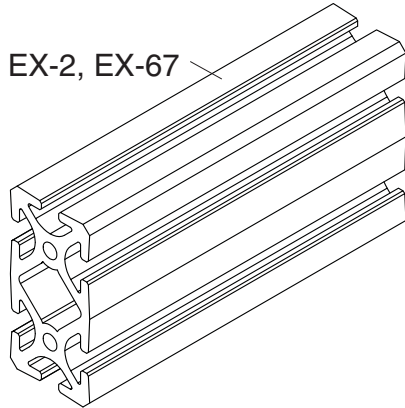

Drilled and C'bored  
for 5/16-18 SHCS (2)

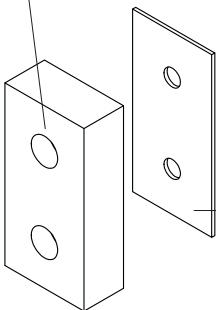

Note: Cross-sectional internal  
area = .7 sq. in.

Cork Gasket Included

Note: tap extrusion holes  
5/16-18 thread

Recommended Hardware  
(2) EF-11-1.0

5/16" SLOTS

**PM-3**

**PM-3**

Drilled and C'bored  
for 5/16-18 SHCS (4)

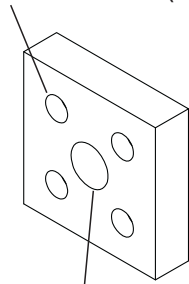

1/2 NPT

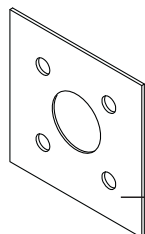

Cork Gasket Included

Note: Cross-sectional internal  
area = 3.5 sq. in.

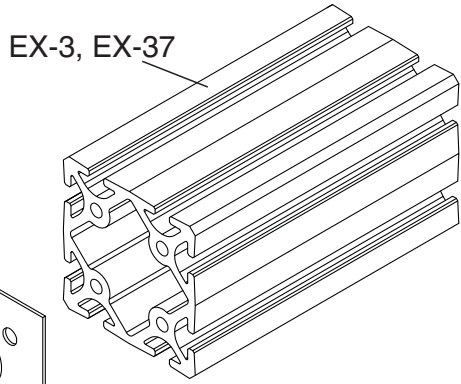

EX-3, EX-37

**PM-3B**

Drilled and C'bored  
for 5/16-18 SHCS (4)

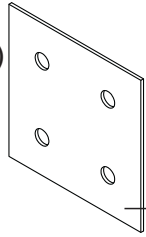
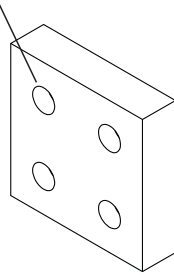

Cork Gasket Included

Note: Cross-sectional internal  
area = 3.5 sq. in.

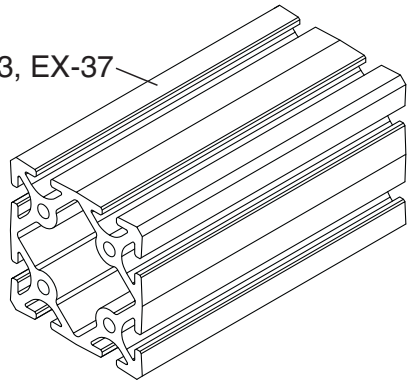

EX-3, EX-37

**5/16" SLOTS**

**Recommended Hardware**  
(4) EF-11-1.0

# Pressure Manifold Plate



PM-31
PM-32

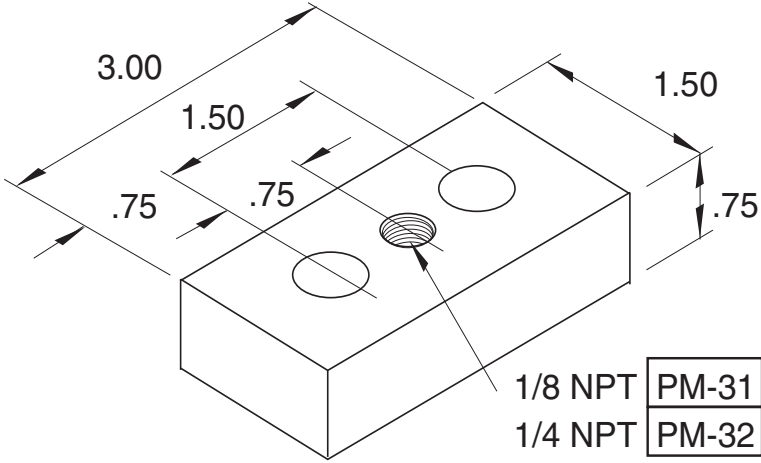

5/16" SLOTS

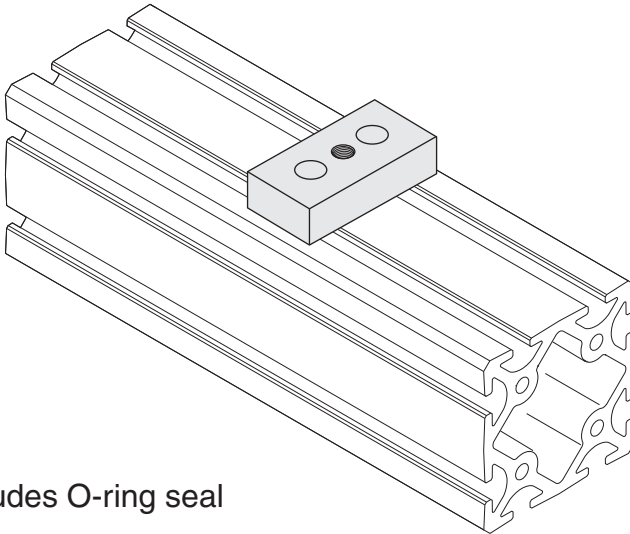

includes O-ring seal

## Recommended Hardware

- (2) EF-11-.875 SHCS
- (2) EF-2 T-nuts

Material - Aluminum  
Finish - Clear Anodize

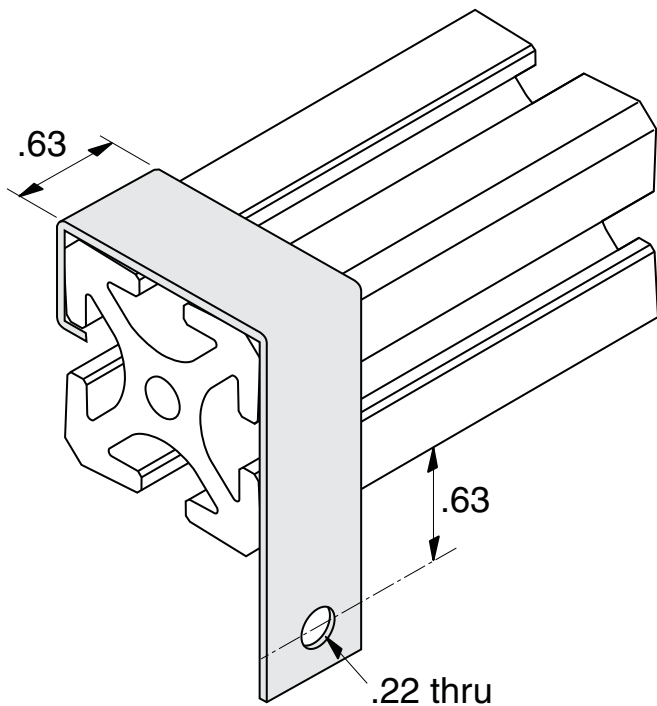

Material  
Zinc Plated Steel



**ETH**

**5/16" SLOTS**

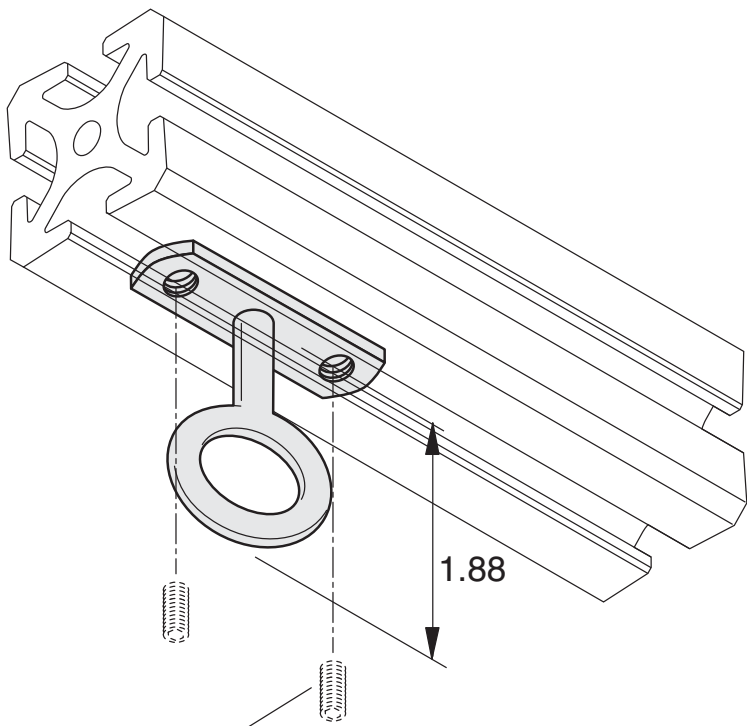

Can be locked in place with  
5/16-18 set screws

Max. load 40 lbs

Material - Steel  
Finish - Zinc Plated

without Snap Hook

**EF-146**

with Snap Hook

**EF-146A**

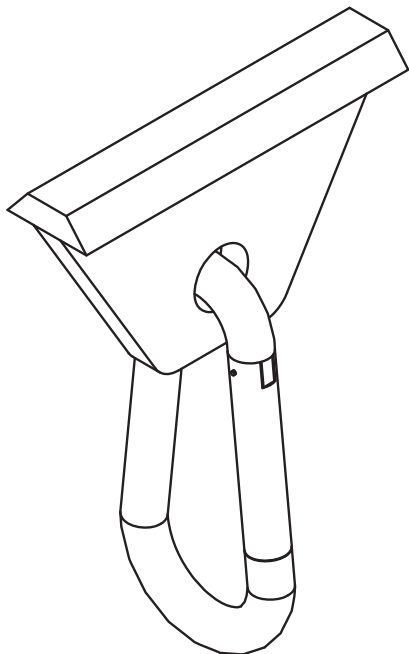

Maximum Load 25 lbs

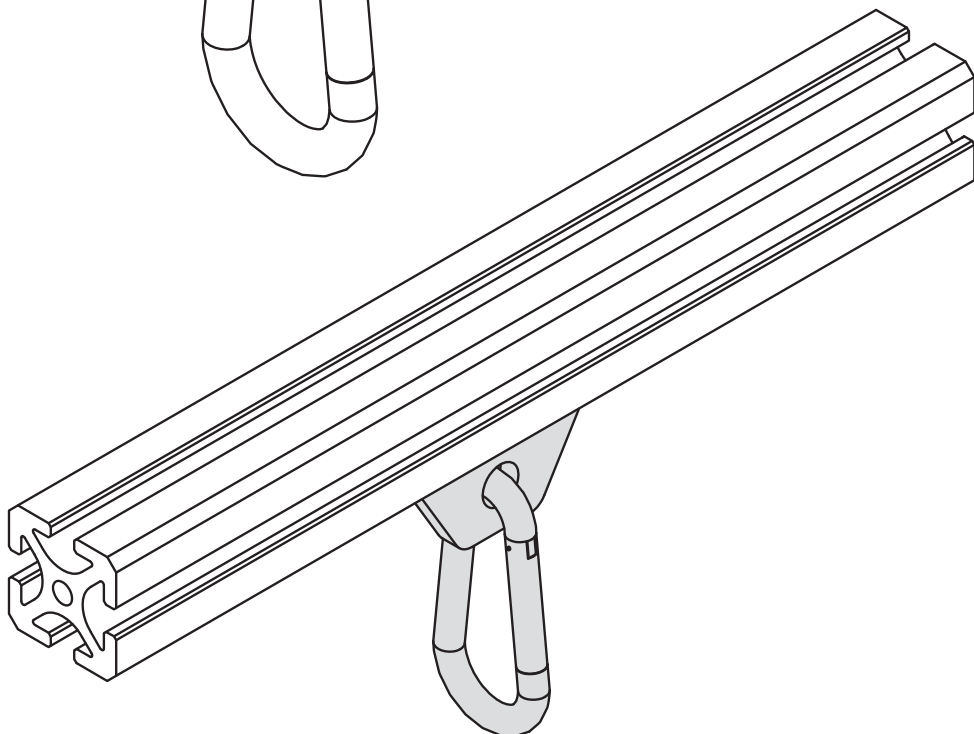

Material

Hanger - Rigid Nylon

Hook - Zinc Plated Steel

5/16" SLOTS

**EF-28**

use on all 5/16" slot extrusions  
with 1.5" sides

5/16" SLOTS

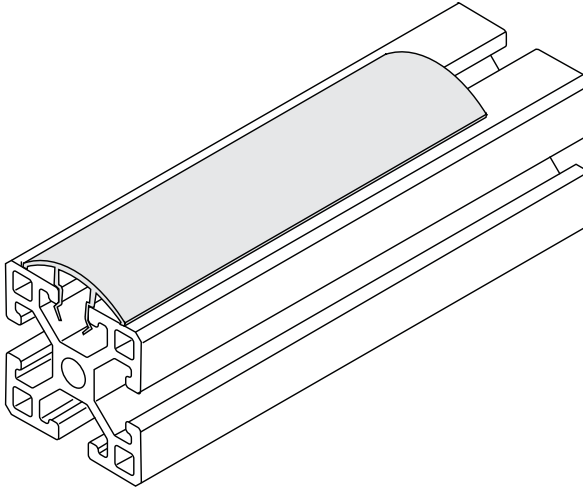

Standard length 72"

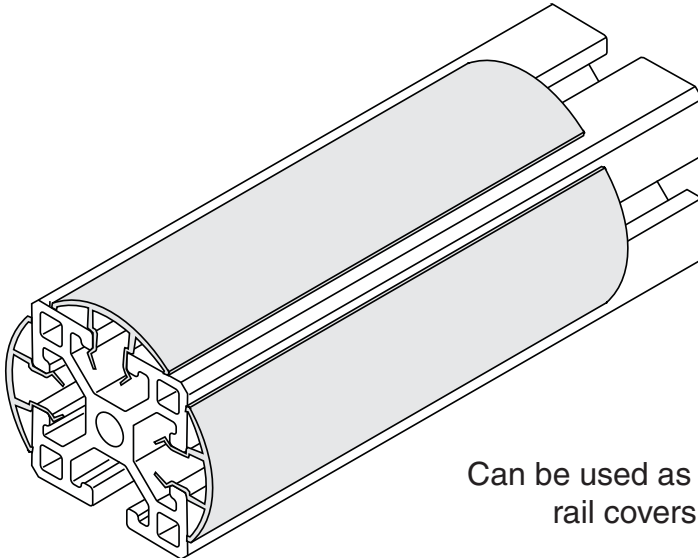

Can be used as hand-  
rail covers

Material - Rigid PVC  
Color - Black

**EF-30A**

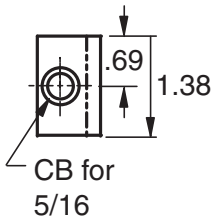

**EF-30B**

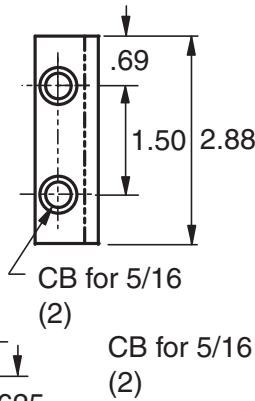

**EF-30C**

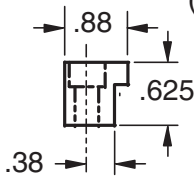
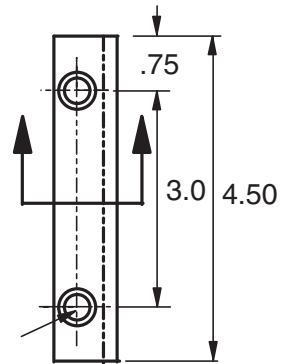

**5/16" SLOTS**

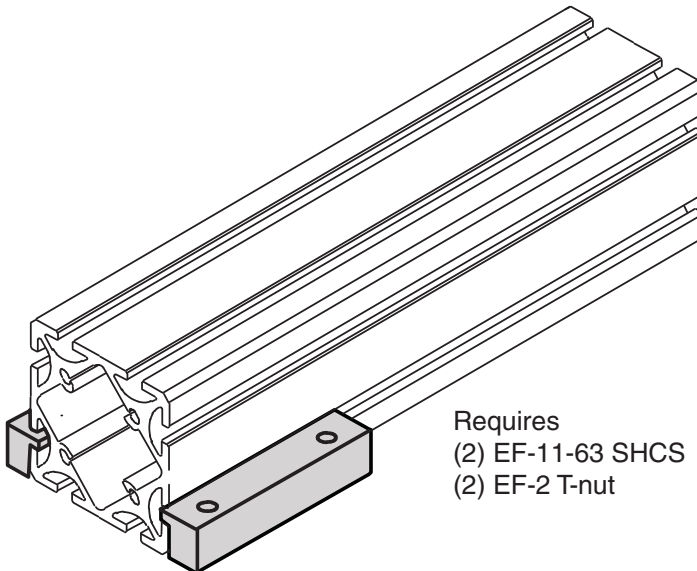

Requires  
(2) EF-11-63 SHCS  
(2) EF-2 T-nut

Material - Aluminum  
Finish - Clear Anodize

**EB-110**

5/16" SLOTS

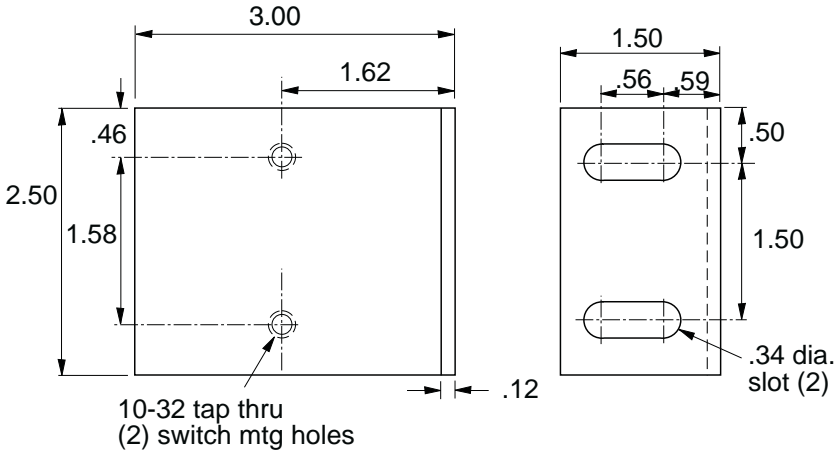

- Requires  
(2) EF-12.5 BHCS  
(2) EF-2 T-nut

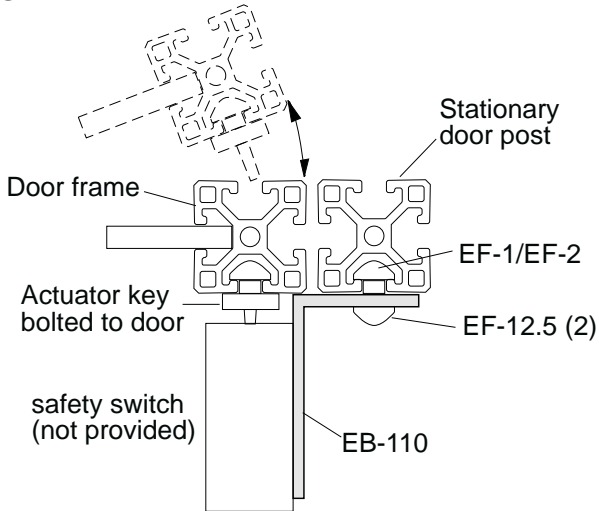

Material - Aluminum  
Finish - Clear Anodize

	Tubing Size	X	Y
<b>EF-42A</b>	3/8"	1.06	.56
<b>EF-42B</b>	1/2"	1.38	.88
<b>EF-42C</b>	3/4"	1.63	1.19
<b>EF-42D</b>	1"	1.69	1.19

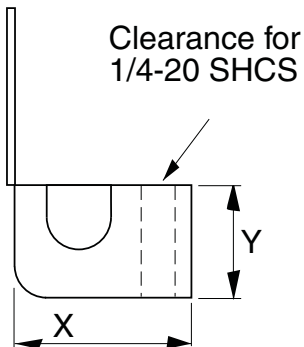

Hardware Required:

- EF-42A** (1) 11-224 SHCS, (1) EF-1A T-nut
- EF-42B** (1) 11-225 SHCS, (1) EF-1A T-nut
- EF-42C** (1) 11-226 SHCS, (1) EF-1A T-nut
- EF-42D** (1) 11-226 SHCS, (1) EF-1A T-nut

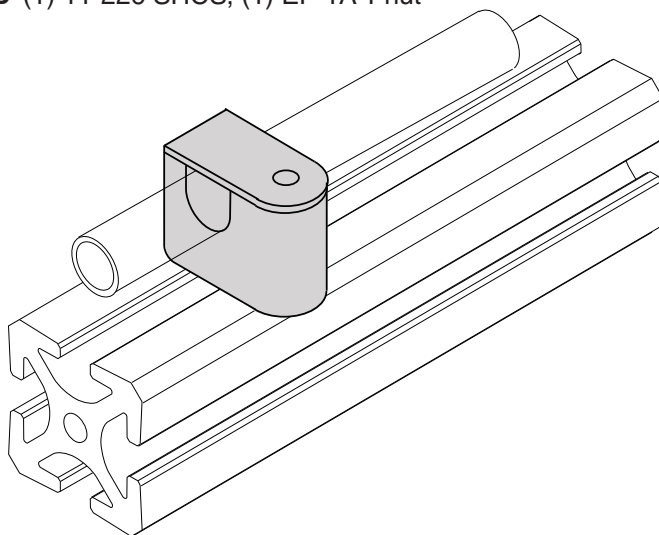

Material - Polypropylene

**5/16" SLOTS**

# Double Tubing Clamp



## EF-43

5/16" SLOTS

	Tubing Size	X	Y
<b>EF-43A</b>	3/8"	1.66	.56
<b>EF-43B</b>	1/2"	2.18	.88
<b>EF-43C</b>	3/4"	2.81	1.19
<b>EF-43D</b>	1"	2.88	1.19

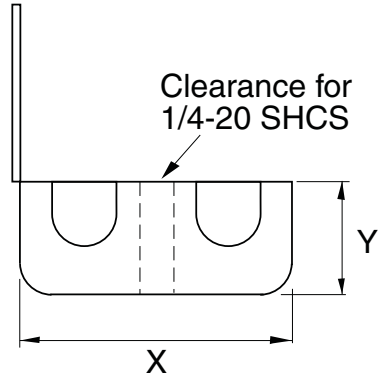

### Hardware Required:

**EF-43A** (1) 11-224 SHCS, (1) EF-1A T-nut

**EF-43B** (1) 11-225 SHCS, (1) EF-1A T-nut

**EF-43C** (1) 11-226 SHCS, (1) EF-1A T-nut

**EF-43D** (1) 11-226 SHCS, (1) EF-1A T-nut

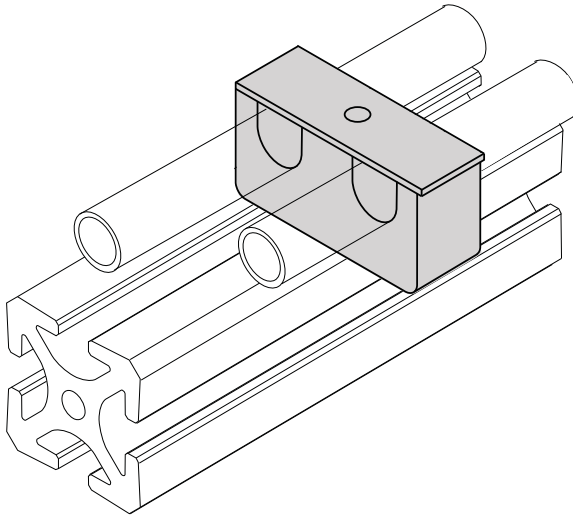

Material - Polypropylene

**EF-80**

**EF-81**

**EF-80**

Hardware Included

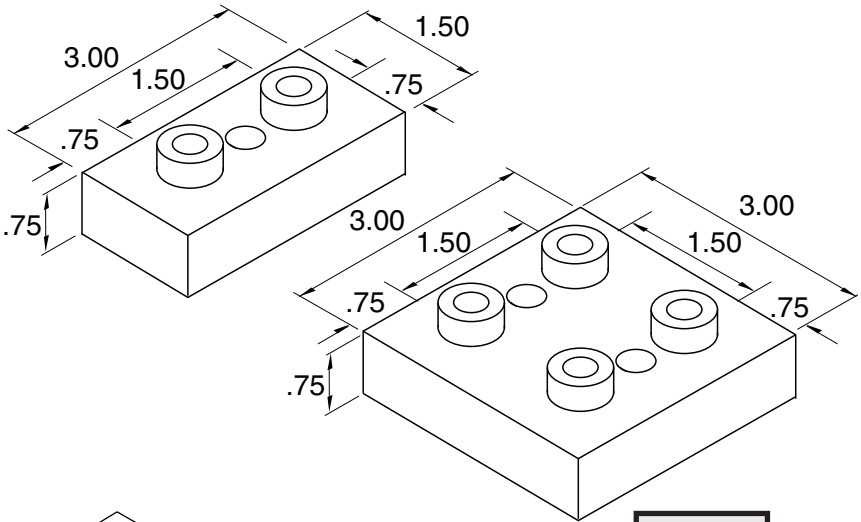

**EF-81**

Hardware Included

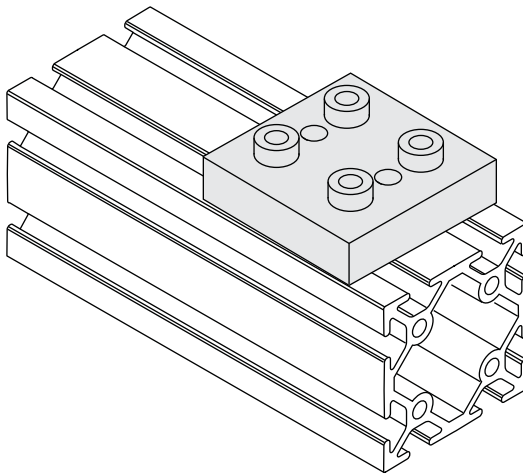

**5/16" SLOTS**

Plate Material - Aluminum  
Finish - Clear Anodize



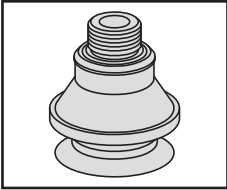

page 313

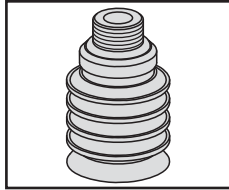

page 314

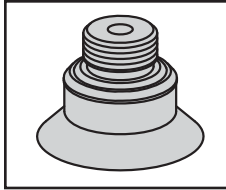

page 315

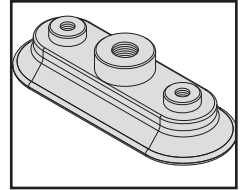

page 316

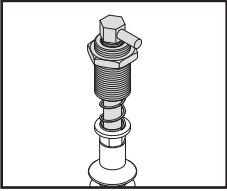

page 317

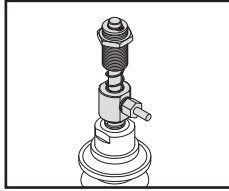

page 318

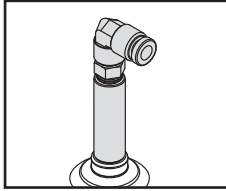

page 319

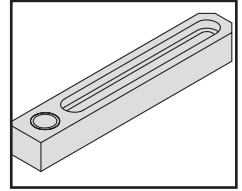

page 320

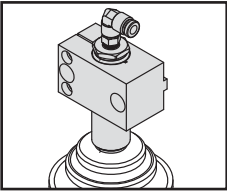

page 321

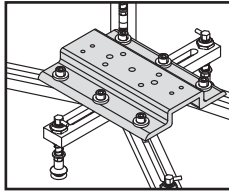

page 322

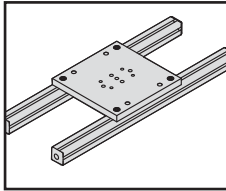

page 323

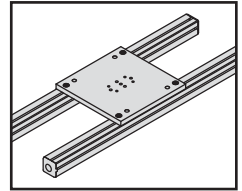

page 324

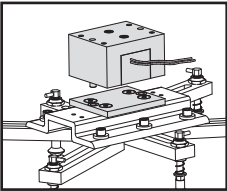

page 325

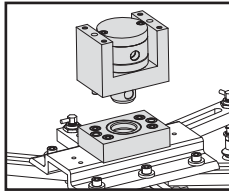

page 326

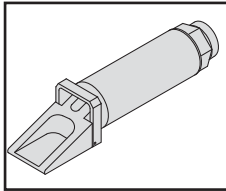

page 327

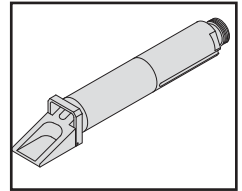

page 328

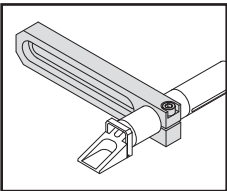

page 329

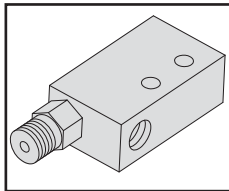

page 330

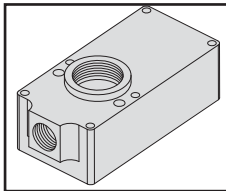

page 331

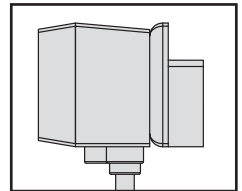

page 332

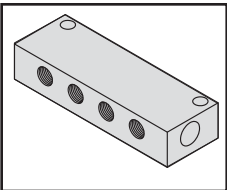

page 333

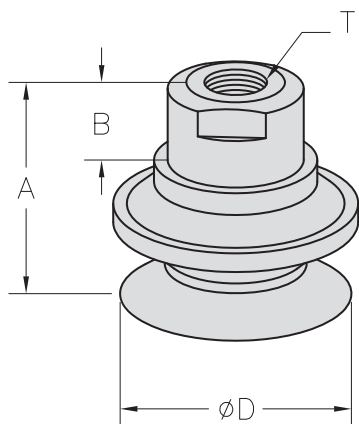

**VB-30**  
**VB-50**  
**VB-75**  
**VB-110**

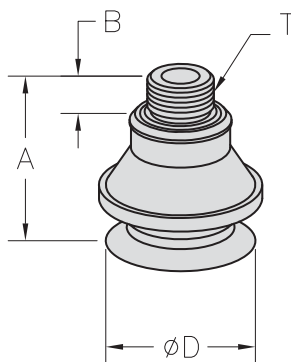

**VB-20**

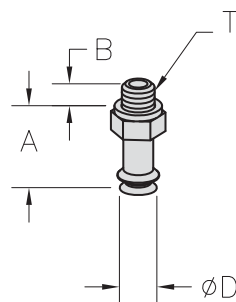

**VB-5**  
**VB-10**  
**VB-15**

MODULAR TOOLING

PART NO NBR	PART NO Silicone	ØD	A	B	T
<b>VB-5</b>	<b>VB-5-S</b>	.22	.52	.14	#10-32
<b>VB-10</b>	<b>VB-10-S</b>	.43	.83	.16	#10-32
<b>VB-15</b>	<b>VB-15-S</b>	.61	.96	.16	#10-32
<b>VB-20</b>	<b>VB-20-S</b>	.87	.81	.24	1/8-NPT
<b>VB-30</b>	<b>VB-30-S</b>	1.34	1.34	.31	1/8-NPT
<b>VB-50</b>	<b>VB-50-S</b>	2.09	1.73	.35	1/8 NPT
<b>VB-75</b>	<b>VB-75-S</b>	3.07	1.97	.71	1/2 NPT
<b>VB-110</b>	<b>VB-110-S</b>	4.53	2.48	.59	1/2 NPT

Cup Material is Nitrile Buna N Rubber (NBR)  
 Silicone is specified with -S suffix

**VMB-Series**

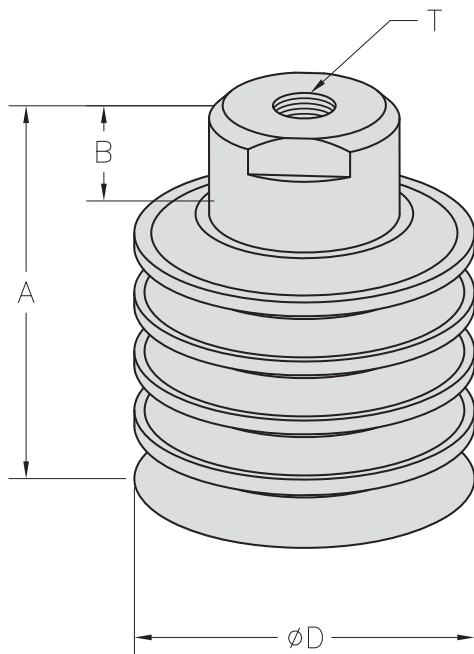

**VMB-50**

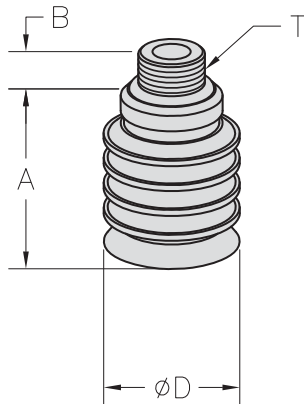

**VMB-20  
VMB-30**

MODULAR TOOLING

PART NO NBR	PART NO Silicone	ØD	A	B	T
VMB-20	VMB-20-S	.79	.96	.24	1/8 NPT
VMB-30	VMB-30-S	1.18	1.46	.28	1/8 NPT
VMB-50	VMB-50-S	1.97	2.36	.35	1/8 NPT

Cup Material is Nitrile Buna N Rubber (NBR)  
Silicone is specified with -S suffix

**VU & VF-Series**

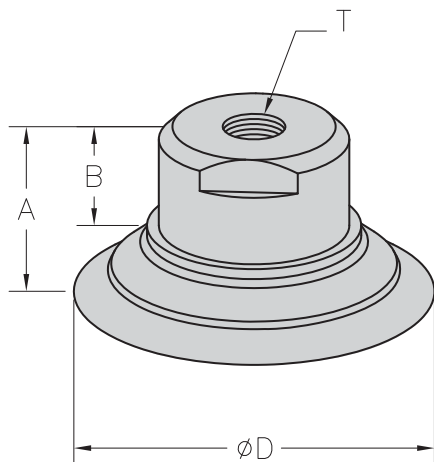

**VF-50  
VF-75  
VF-110**

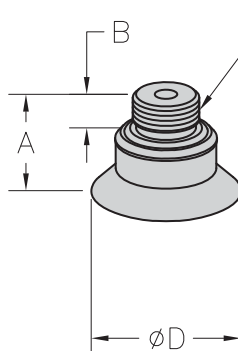

**VF-20  
VF-30**

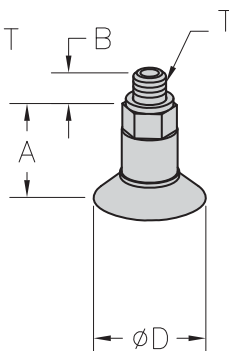

**VU-6  
VU-10  
VF-15**

**MODULAR TOOLING**

PART NO NBR	PART NO Silicone	ØD	A	B	T
<b>VU-6</b>	<b>VU-6-S</b>	.28	.41	.14	#10-32
<b>VU-10</b>	<b>VU-10-S</b>	.43	.61	.14	#10-32
<b>VF-15</b>	<b>VF-15-S</b>	.65	.63	.16	#10-32
<b>VF-20</b>	<b>VF-20-S</b>	.87	.37	.24	1/8 NPT
<b>VF-30</b>	<b>VF-30-S</b>	1.26	.45	.24	1/8 NPT
<b>VF-50</b>	<b>VF-50-S</b>	2.09	1.04	.35	1/8 NPT
<b>VF-75</b>	<b>VF-75-S</b>	3.03	1.02	.71	1/2 NPT
<b>VF-110</b>	<b>VF-110-S</b>	4.41	1.14	.59	1/2 NPT

Cup Material is Nitrile Buna N Rubber (NBR)  
Silicone is specified with -S suffix

# Vacuum Cups Oval



## VOC-Series

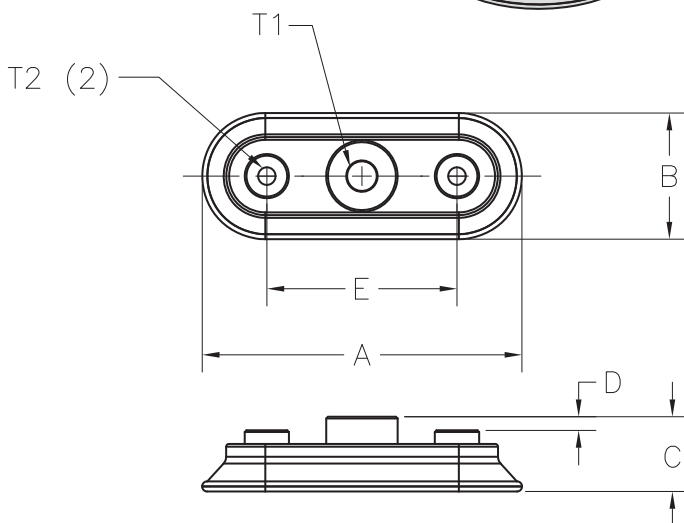
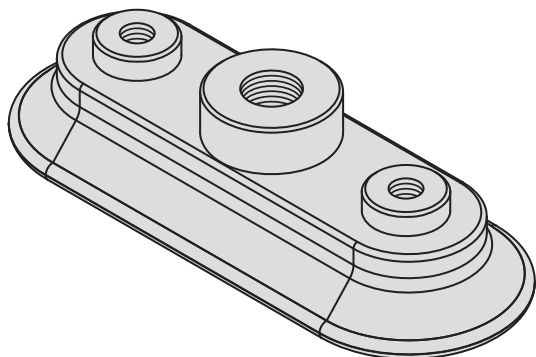

MODULAR TOOLING

PART NO	A	B	C	D	E	T1	T2
VOC-35	3.70	1.46	.87	.16	2.20	1/8 NPT	m6
VOC-60	5.51	2.40	1.18	.16	2.99	3/8 NPT	m8

MODEL	(in <sup>3</sup> )	LIFTING FORCE (lb) Perpendicular			LIFTING FORCE (lb) Parallel		
		2.9 psi	8.7 psi	13.0 psi	2.9 psi	8.7 psi	13.0 psi
VOC-35	1.22	11.02	29.54	38.36	15.21	36.16	42.3
VOC-60	3.17	29.54	83.78	116.84	41.67	83.78	114.64

Cup Material is Nitrile Buna N Rubber (NBR)

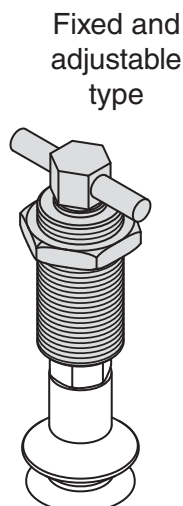
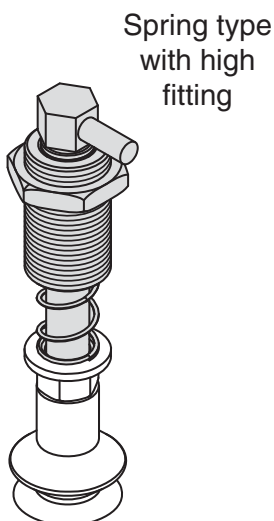
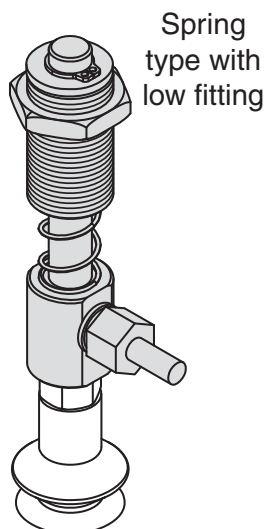

Note: Vacuum cups sold separately

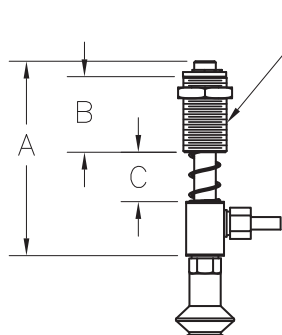

MT-ST-B

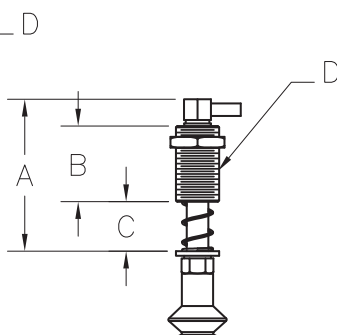

MT-ST-A

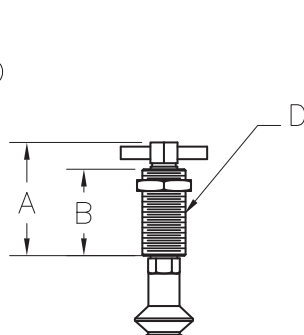

MT-ST-C

Fittings accept  $\text{\O}1/4$  tubing

PART NO	A	B	C	D	USE WITH VACUUM CUPS
MT-ST-A	1.81	.88	.53	1/2-20	VB-5, VB-10, VB-15, VU-6, VU-10, VF-15
MT-ST-B	2.25	.88	.53	1/2-20	
MT-ST-C	3.31	1.00	--	1/2-20	

# Medium Vacuum Stems



## MT-ST

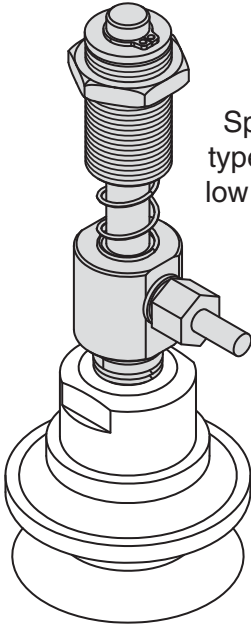

Spring type with low fitting

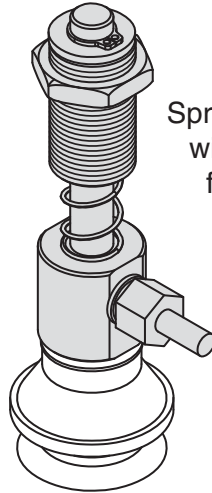

Spring type with low fitting

Note: Vacuum cups sold separately

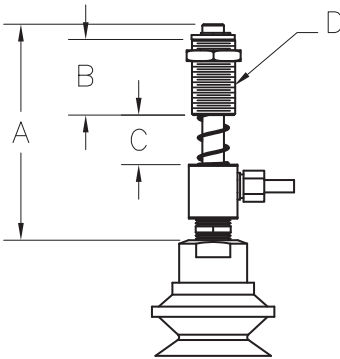

MT-ST-E

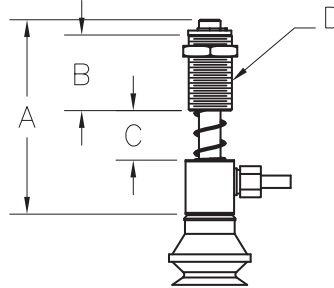

MT-ST-D

Fittings accept Ø1/4 tubing

PART NO	A	B	C	D	USE WITH VACUUM CUPS
MT-ST-D	2.25	.88	.53	1/2-20	VB-20, VF-20
MT-ST-E	2.50	.88	.53	1/2-20	VB-30, VB-50, VF-30, VF-50

MODULAR TOOLING

### MT-ST

Rigid clamp type with top fitting

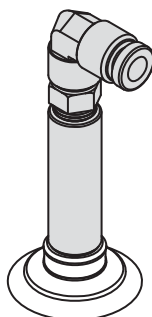

MT-ST-F  
MT-ST-G

Rigid clamp type with bottom fitting

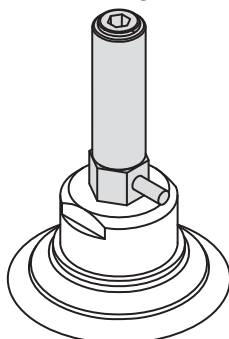

MT-ST-H

Spring type with top fitting

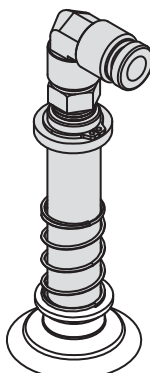

MT-ST-I  
MT-ST-J

Spring type with bottom fitting

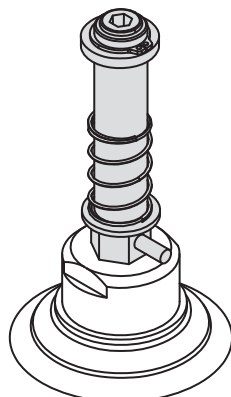

MT-ST-K

Note: Vacuum cups sold separately

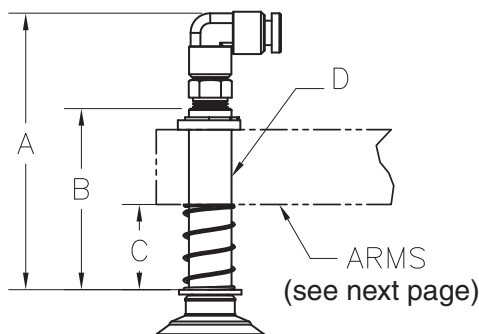
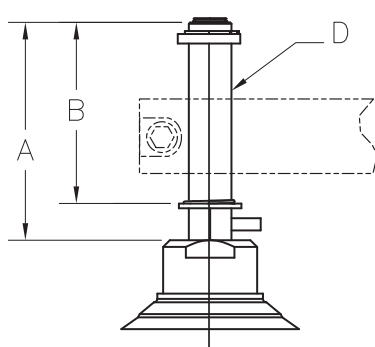

Fittings accept  $\text{\O}1/4$  tubing

PART NO	A	B	C	D	SPRING	USE WITH VACUUM CUPS
MT-ST-F	2.62	1.50	--	$\text{\O}0.50$	NO	VF-20, VF-30, VB-20, VB-30
MT-ST-G	2.87	1.50	--	$\text{\O}0.50$	NO	VF-50, VB-50
MT-ST-H	1.88	1.50	--	$\text{\O}0.50$	NO	VF-50, VB-50
MT-ST-I	3.25	2.13	1.00	$\text{\O}0.50$	YES	VF-20, VF-30, VB-20, VB-30
MT-ST-J	3.50	2.13	1.00	$\text{\O}0.50$	YES	VF-50, VB-50
MT-ST-K	2.56	1.88	1.00	$\text{\O}0.50$	YES	VF-50, VB-50



**MT-VA**

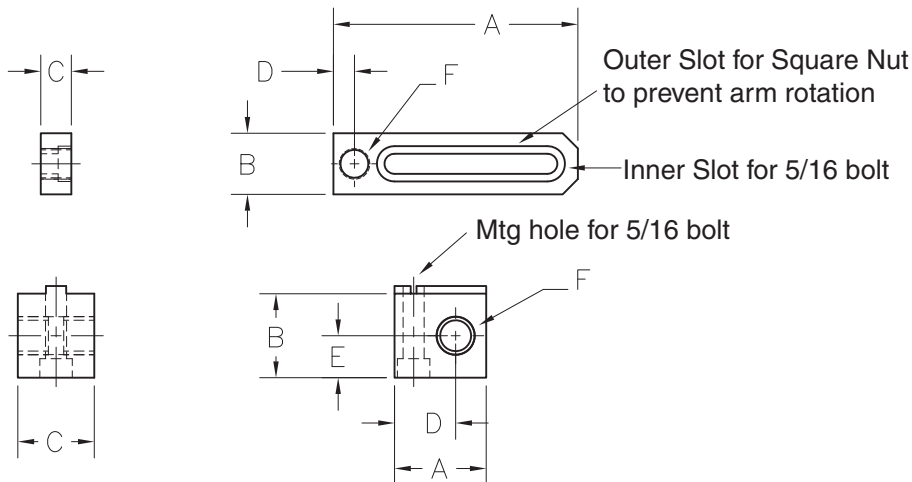
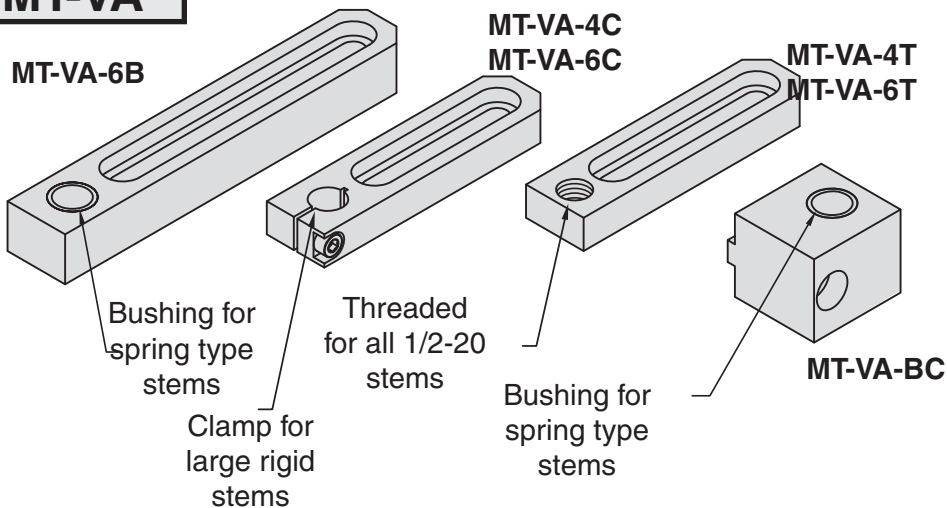

MODULAR TOOLING

Requires Square Nut **SMN-56**

PART NO	A	B	C	D	E	F
MT-VA-4T	4.00	1.00	.50	.34	--	1/2-20 THD.
MT-VA-6T	6.00	1.00	.50	.34	--	1/2-20 THD
MT-VA-4C	4.00	1.00	.50	.56	--	Ø.50 CLAMP
MT-VA-6C	6.00	1.00	.50	.56	--	Ø.50 CLAMP
MT-VA-6B	6.00	1.00	.50	.62	--	Ø.50 BUSHING
MT-VA-BC	1.50	1.38	1.25	1.00	.69	Ø.50 BUSHING

Material - Aluminum  
Finish - Clear Anodize

**MT-STL-CL**

**MT-STL-SP**

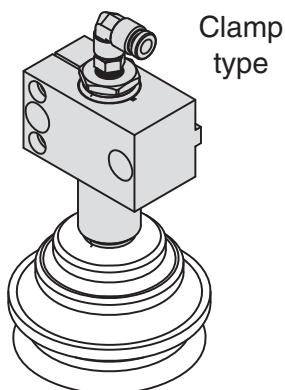

**MT-STL-CL**

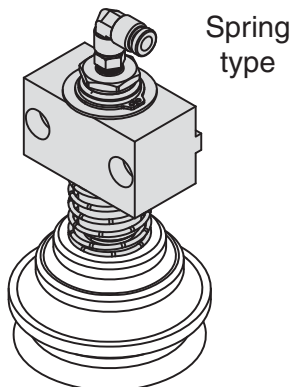

**MT-STL-SP**

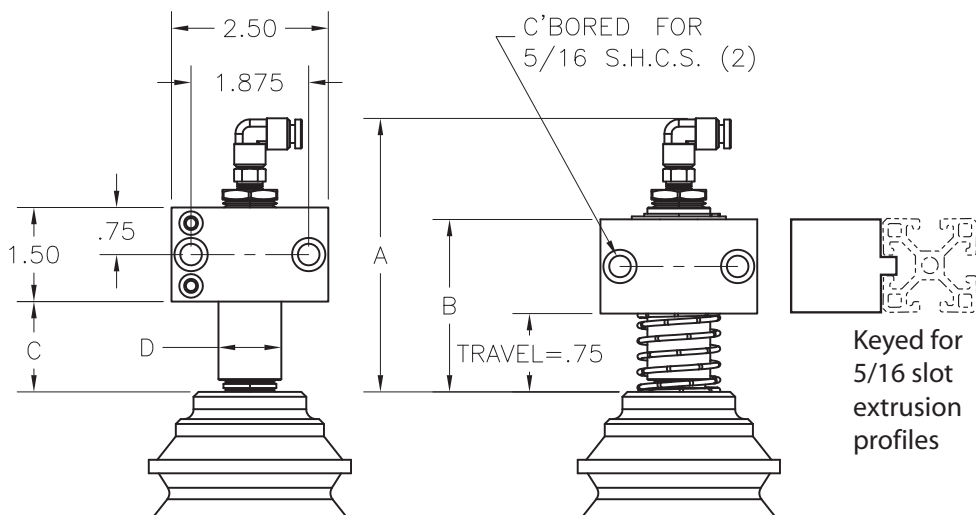

Fittings Accept Ø1/4 Tubing

PART NO	A	B	C	D	SPRING	USE WITH VACUUM CUPS
MT-STL-CL	4.36	2.94	1.44	Ø1.00	NO	VB-75, VB-150 VF-75, VF-150
MT-STL-SP	4.36	2.75	--	Ø1.00	YES	VB-75, VB-150 VF-75, VF-150

Note: Vacuum cups sold separately

# Small Vacuum Assembly Plate



## MT-SAS

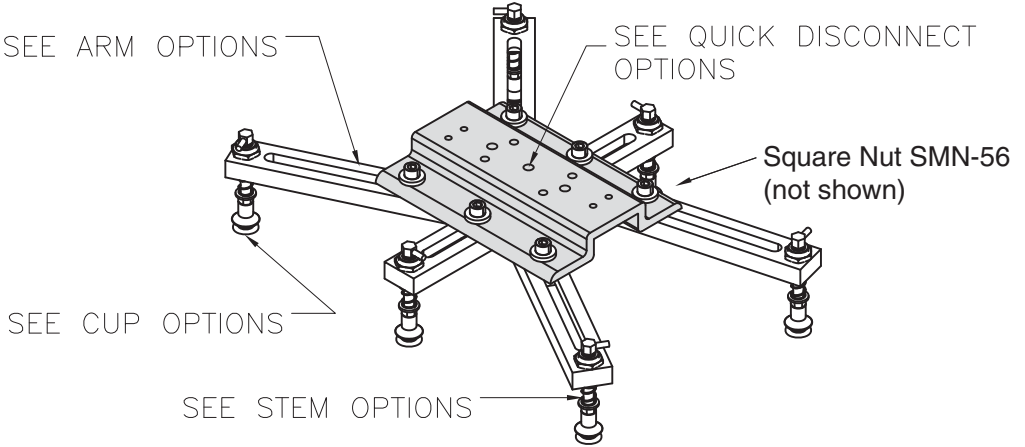

MODULAR TOOLING

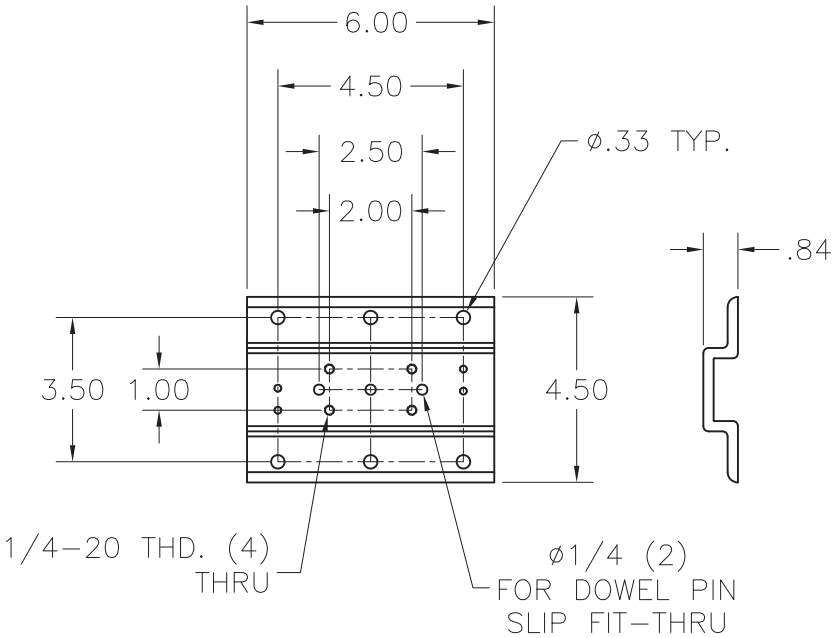
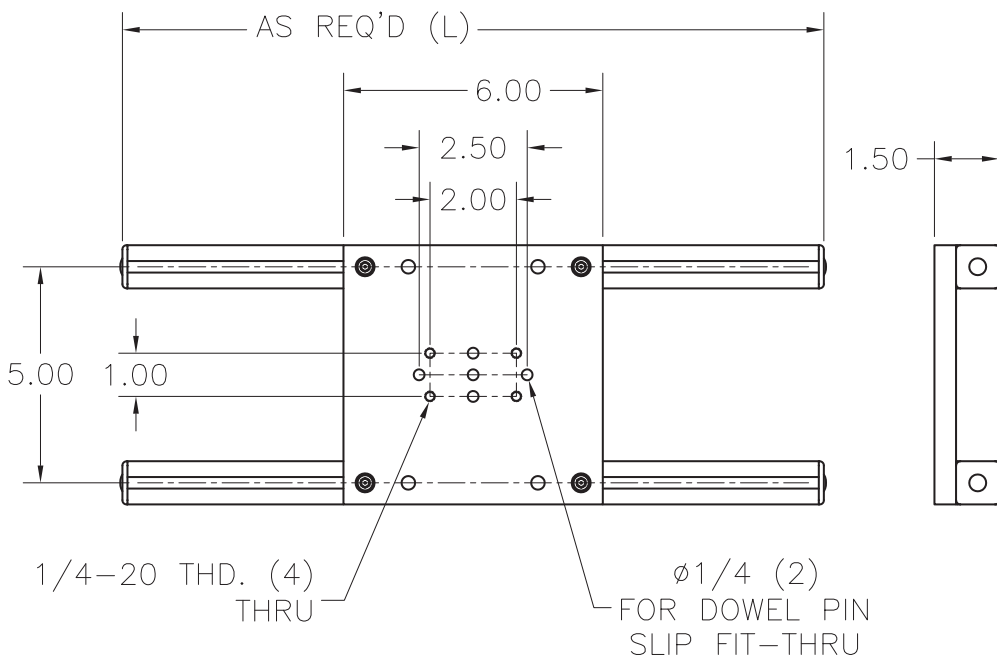
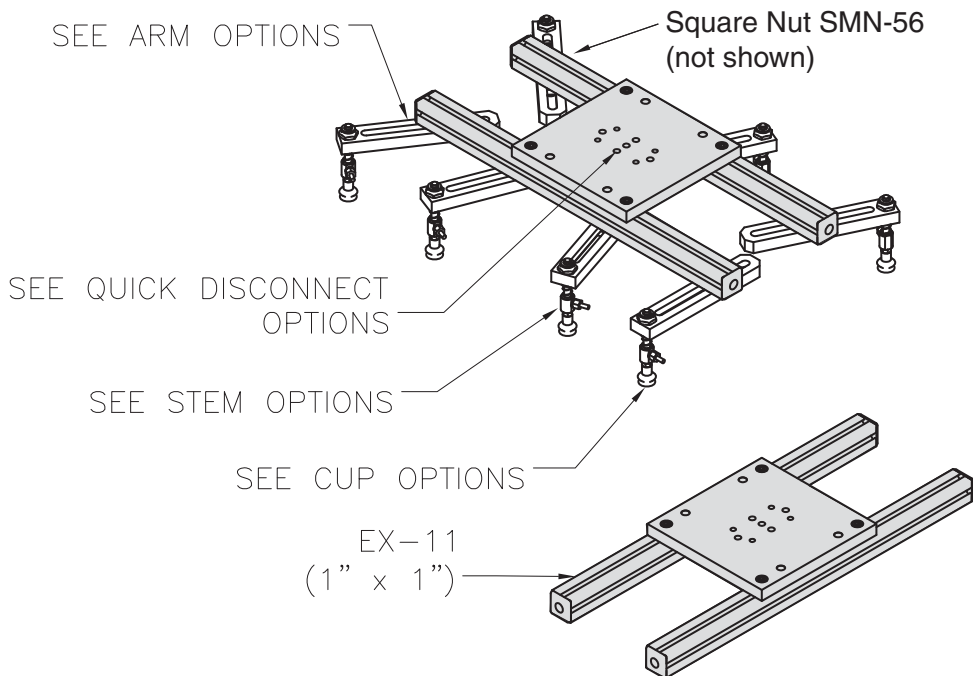

Plate Material - Aluminum  
Finish - Clear Anodize

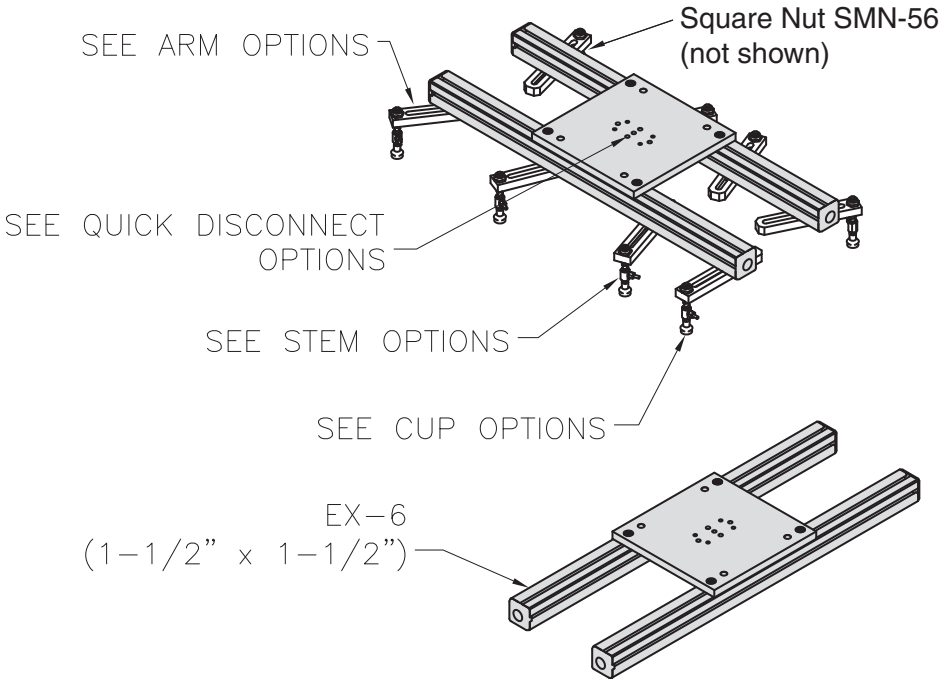

**Plate Material - Aluminum**  
**Finish - Clear Anodize**

# Large Vacuum Assembly Plate



## MT-LAS



MODULAR TOOLING

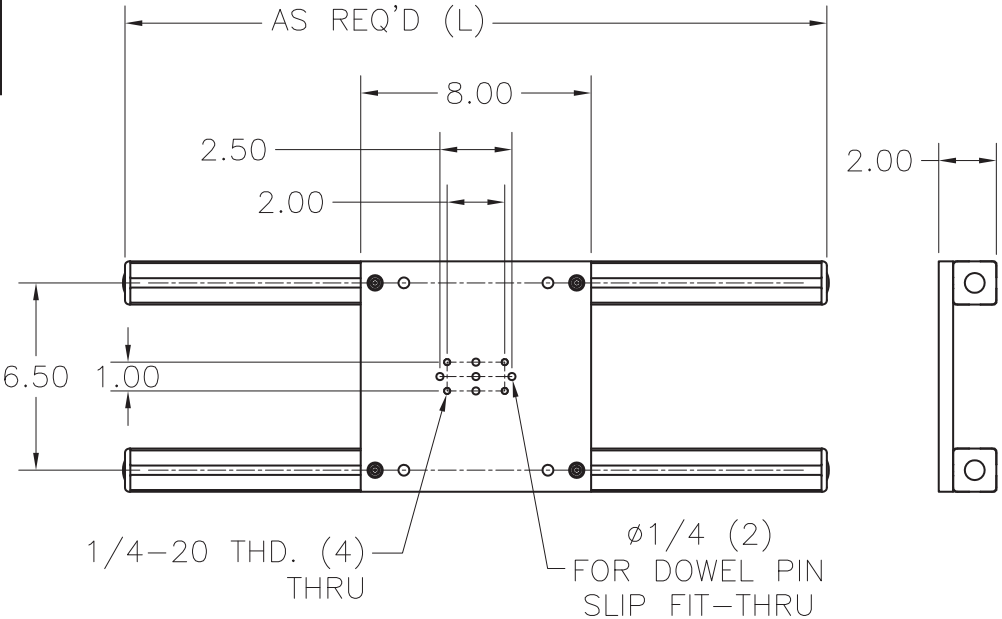
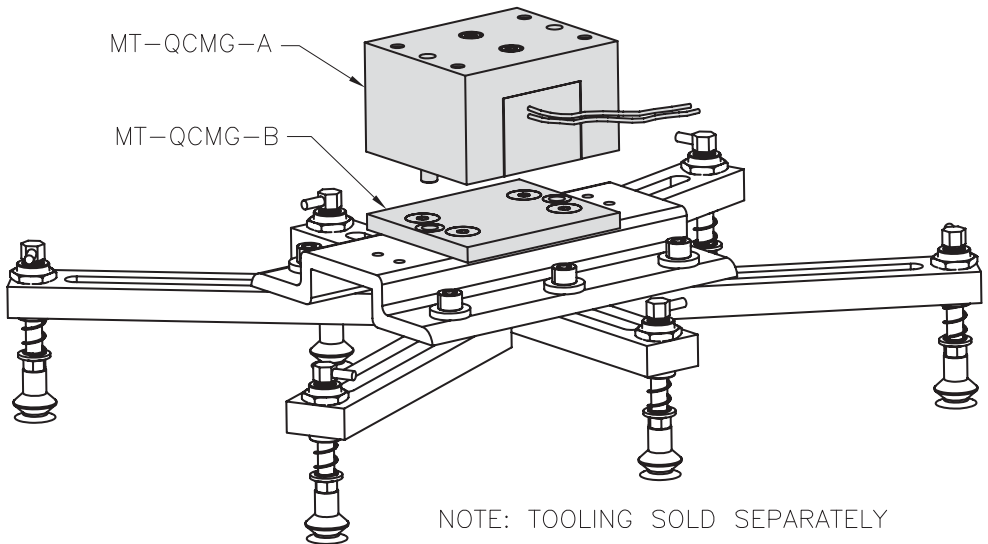
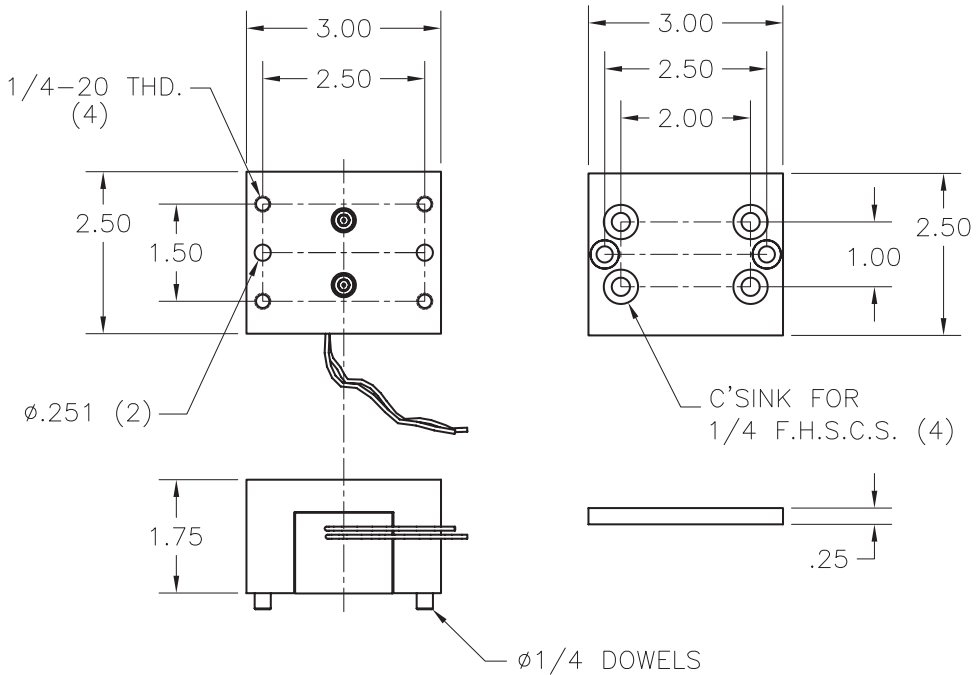

Plate Material - Aluminum  
Finish - Clear Anodize

**MT-QCMG-A**  
**MT-QCMG-B**



NOTE: TOOLING SOLD SEPARATELY



DC-POWERED ELECTROMAGNET  
REQUIRES A DC POWER SUPPLY  
10 WATTS, 12VDC  
MAX. PULL 160 lbs.

**MODULAR TOOLING**

# Pneumatic Quick Change Module



**MT-QCPN-A**  
**MT-QCPN-B**

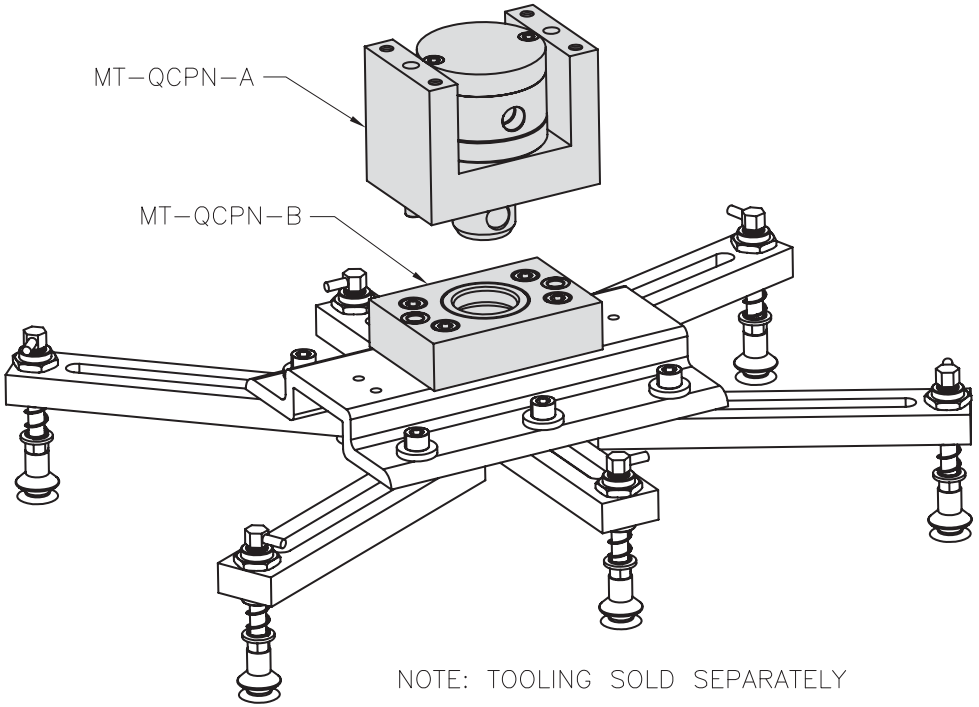

NOTE: TOOLING SOLD SEPARATELY

MODULAR TOOLING

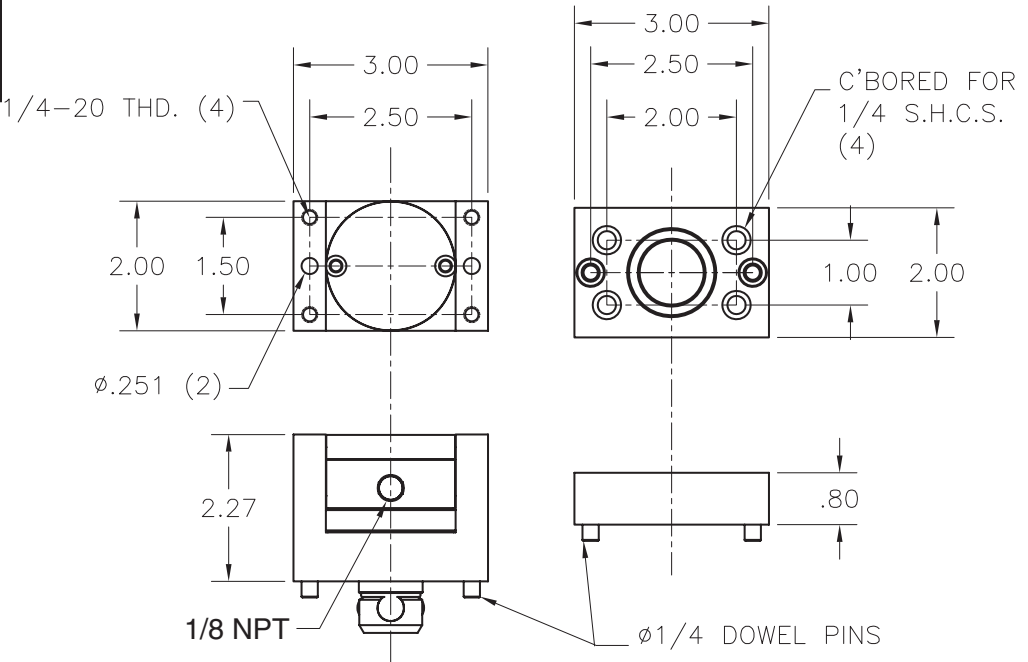

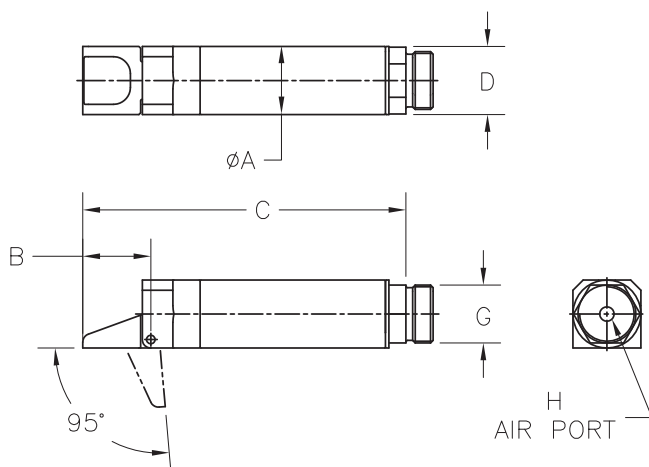
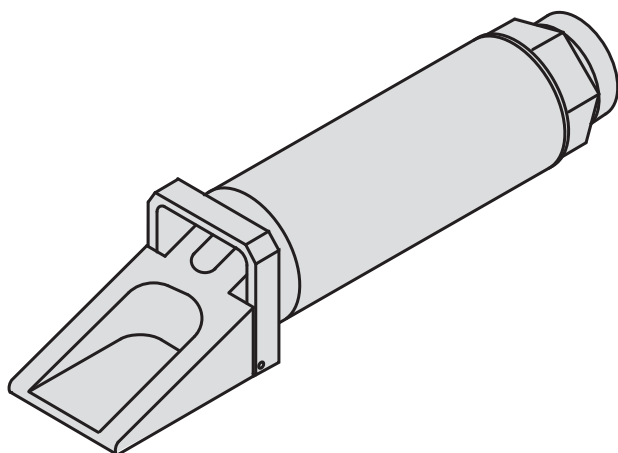

PART NO.	A	B	C	D	G	STROKE	H	CLOSING FORCE*
MT-MCL-1	Ø.787	.787	3.74	.787	M17 x 1	95°	M5	16 lbf

\* at 87 PSI



# 90° Mini Clamp (Sensor)



## MT-MCL-2

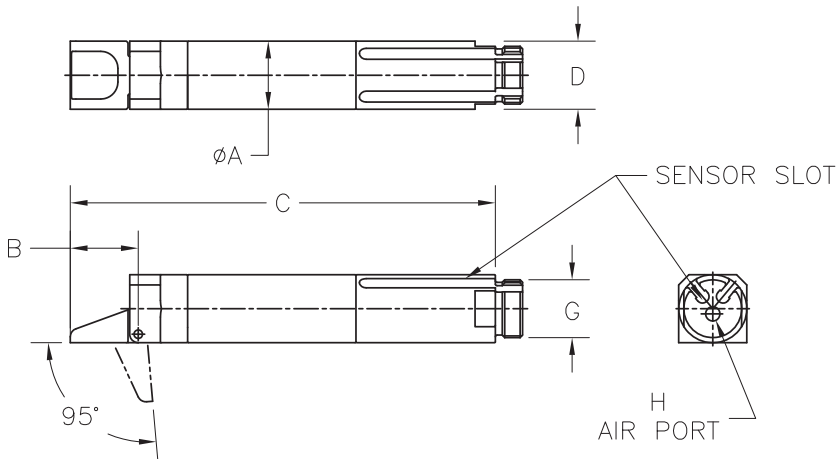
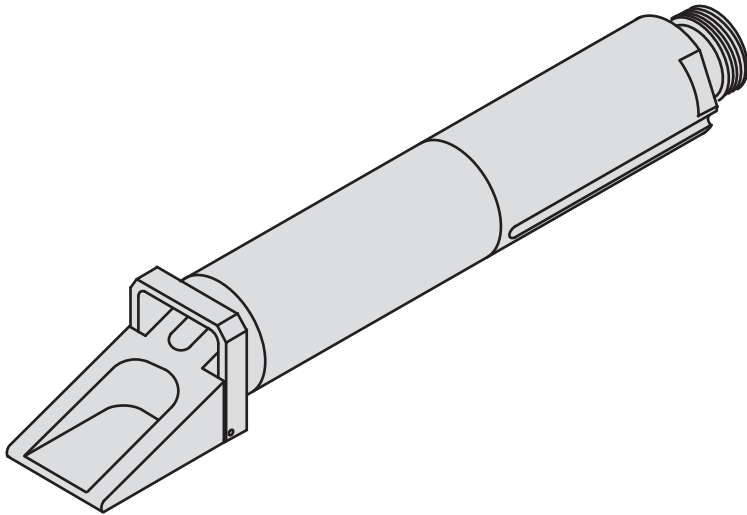

MODULAR TOOLING

PART NO.	A	B	C	D	G	STROKE	H	CLOSING FORCE*
MT-MCL-2	Ø.787	.787	4.92	.787	M17 x 1	95°	M5	16 lbf

\* at 87 PSI

Order Sensors Separately

MT-MCL-SP	PNP Sensor	3-wire, 78.74" long cable	6-24 vdc
MT-MCL-SN	NPN Sensor	3-wire, 78.74" long cable	6-24 vdc

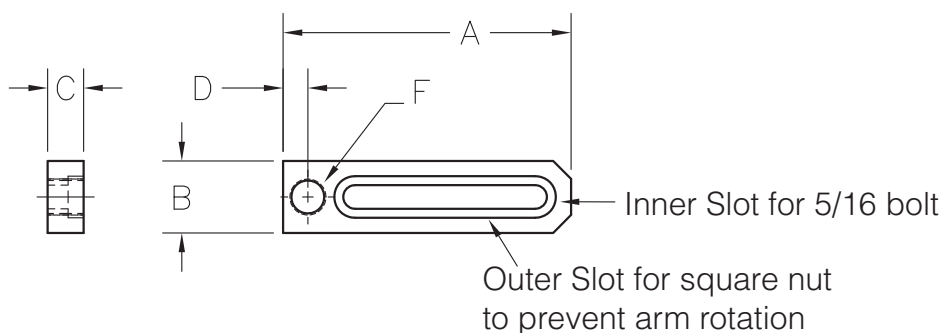
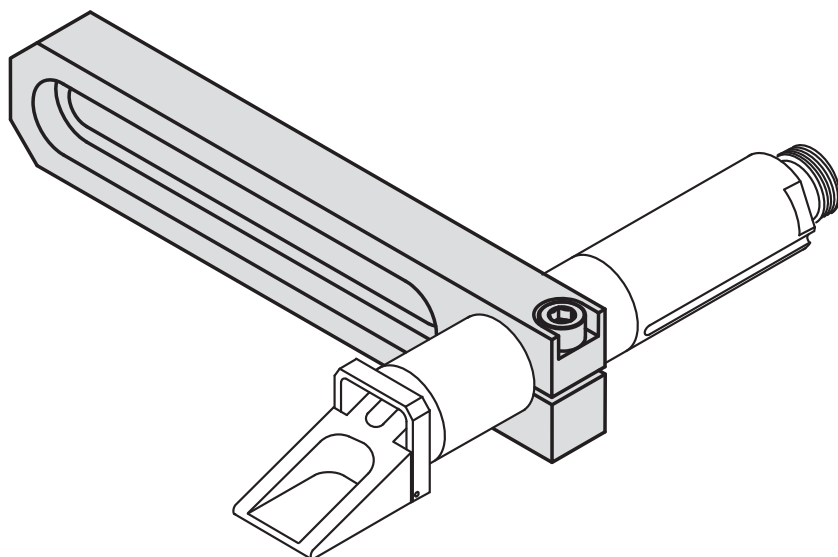

PART NO	A	B	C	D	E	F
<b>MT-MCA- 4C</b>	4.00	1.00	.50	.56	--	Ø.75 CLAMP
<b>MT-MCA-6C</b>	6.00	1.00	.50	.56	--	Ø.75 CLAMP

Requires Square Nut **SMN-56**

Material - Aluminum  
Finish - Clear Anodize

# Vacuum Generator



## VGEN-1

P=COMPRESSED AIR CONNECTION  
 V=VACUUM CONNECTION  
 E=EXHAUST

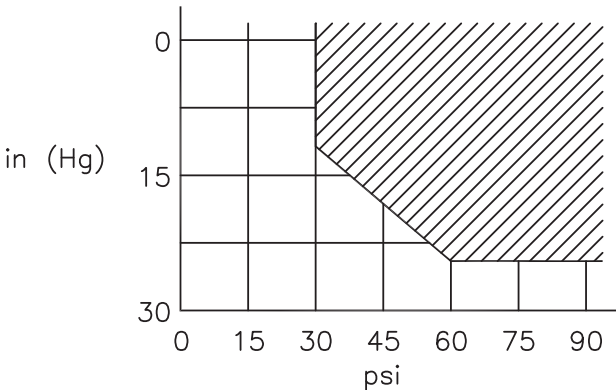
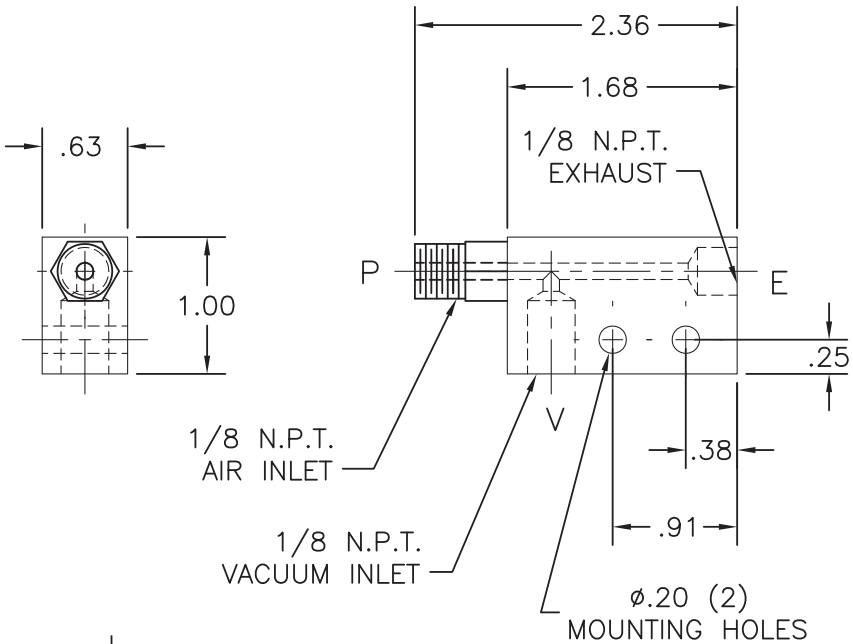
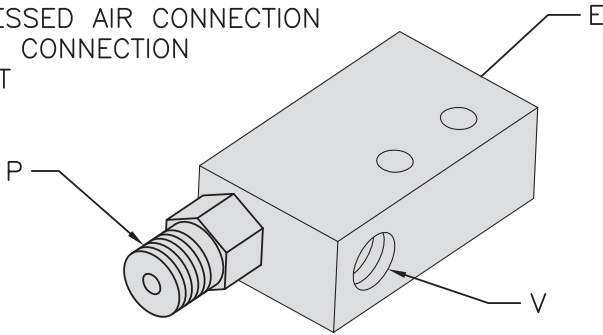

Capacity: Approx 4 in<sup>2</sup>

GRAPH OF SUPPLY PRESSURE vs. VACUUM PRODUCED

MODULAR TOOLING

P=COMPRESSED AIR CONNECTION  
V=VACUUM CONNECTION  
E=EXHUAST

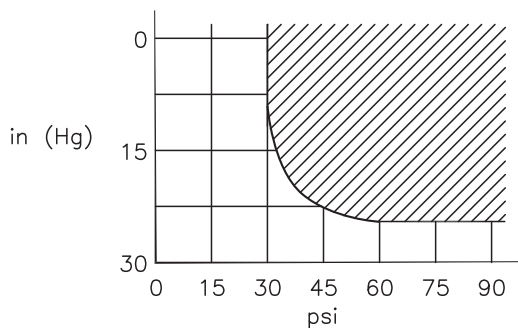
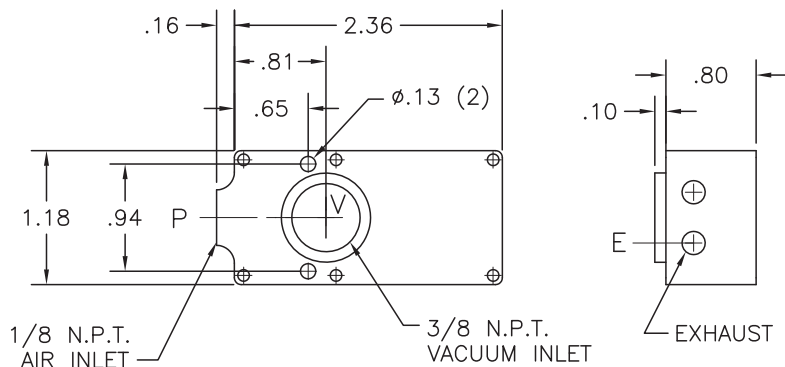
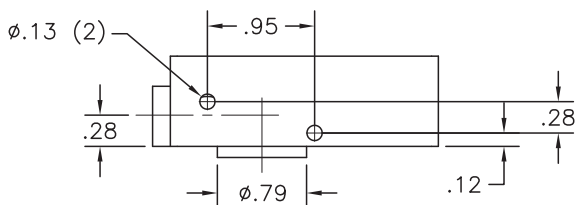
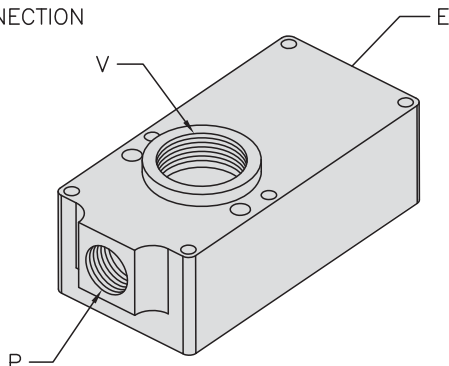

Capacity: Approx 10 in<sup>2</sup>

GRAPH OF SUPPLY PRESSURE vs. VACUUM PRODUCED

# Vacuum Switch



## VSW-1

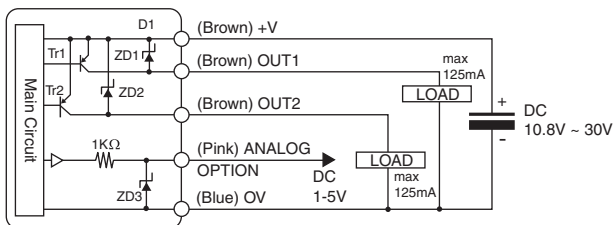
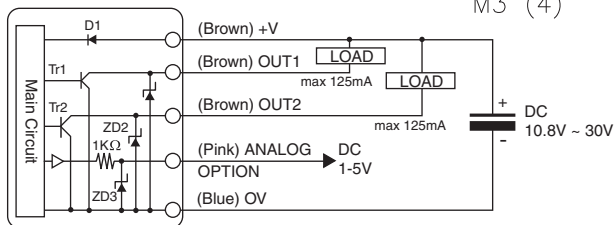
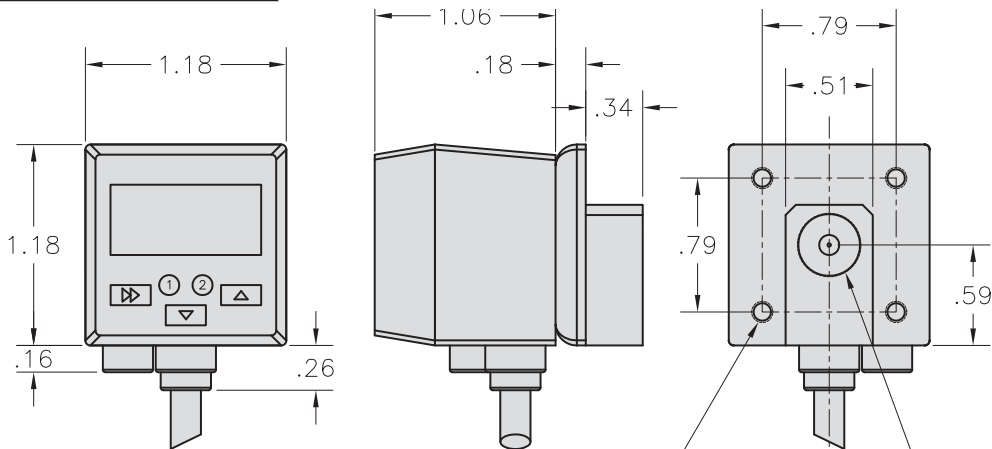

MODULAR TOOLING

SPECIFICATIONS	
APPLICABLE FLUID	NON-CORROSIVE GASES
PRESSURE RANGE	0.0 ~ - 101.3 kPa
PRESSURE PROOF FORCE	500 kPa
MATERIAL OF PRESSURE PORT	Zn DIE CASTING
POWER SUPPLY VOLTAGE	12~24 VDC ± 10%, RIPPLE (P-P) 10% or LESS
POWER CONSUMPTION	55 mA or LESS
OUTPUT	NPN or PNP OPEN COLLECTOR 2 OUTPUTS, MAX 80 mA
RESPONSE TIME	≤2.5 ms (CHATTERING-PROOF FUNCTION: 24ms, 192ms AND 768 ms SELECTIONS)
PROTECTION STRUCTURE	IP 40
OPERATING AMBIENT TEMPERATURE (°C)	OPERATION: 0~50°C , STORAGE: -20~60°C (NO CONDENSATION FREEZING)

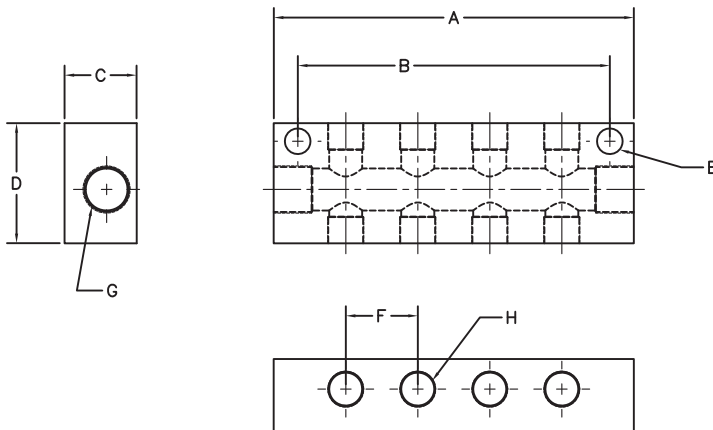
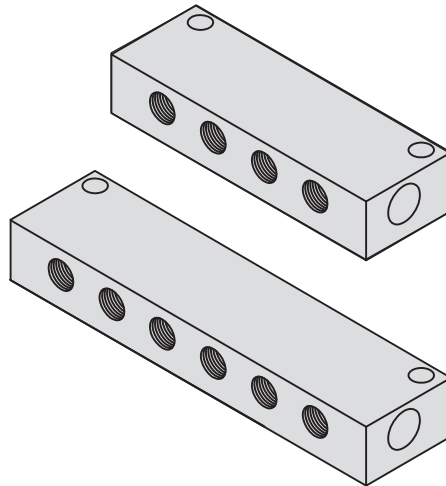

**MODULAR TOOLING**

PART NO	PORTS	A	B	C	D	E	F	G	H
<b>MT-MFD-L8</b>	8	3.75	3.25	.75	1.25	Ø.27	.75	1/4 NPT (2)	1/8 NPT (8)
<b>MT-MFD-L12</b>	12	5.25	4.75	.75	1.25	Ø.27	.75	1/4 NPT (2)	1/8 NPT (12)
<b>MT-MFD-S8</b>	8	3.00	2.50	.63	1.00	Ø.20	.50	1/8 NPT (2)	10-32 THD. (8)
<b>MT-MFD-S12</b>	12	4.00	3.50	.63	1.00	Ø.20	.50	1/8 NPT (2)	10-32 THD. (8)



**EX-11**  
1" x 1"



**EX-12**  
1" x 2"

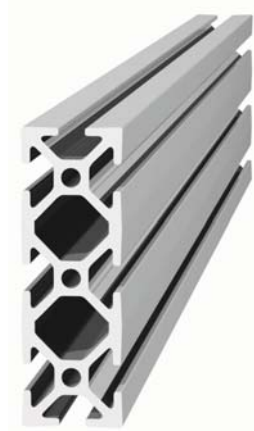

**EX-13**  
1" x 3"



**EX-22**  
2" x 2"

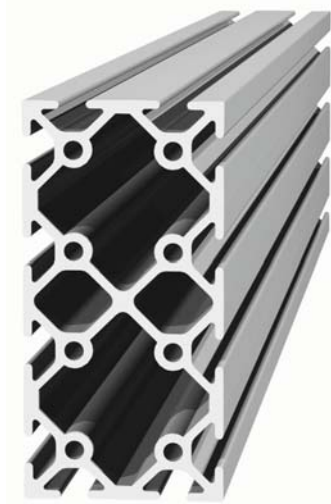

**EX-24**  
2" x 4"

1/4" SLOTS

**SMOOTH-Series**



**EX-70**  
1" x 1"

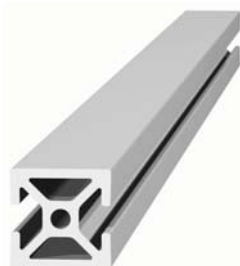

**EX-71**  
1" x 1"

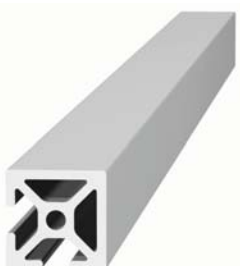

**EX-72**  
1" x 1"



**EX-73**  
1" x 1"



**EX-14**  
1" x 1"



**EX-11**

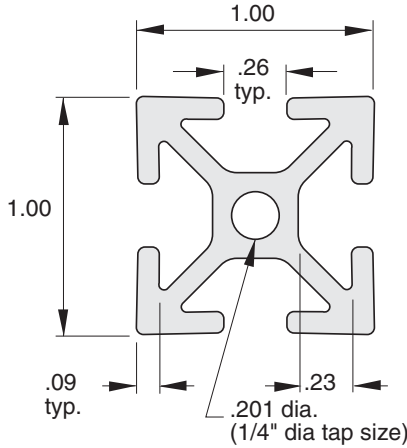

- Finish = Clear anodized
- Material = 6105-T5 Aluminum
- Est. Area = .451 Sq. In.
- Weight/ft = .530 lbs.
- 96", 144.25", 192.63" Lengths standard.

**Section Properties:**

Moment of Intertia in <sup>4</sup>	.049
Section modulus in <sup>3</sup>	.097

**EX-12**

- Finish = Clear anodized
- Material = 6105-T5 Aluminum
- Est. Area = .807 Sq. In.
- Weight/ft = .949 lbs.
- 96", 192.63" Lengths standard.

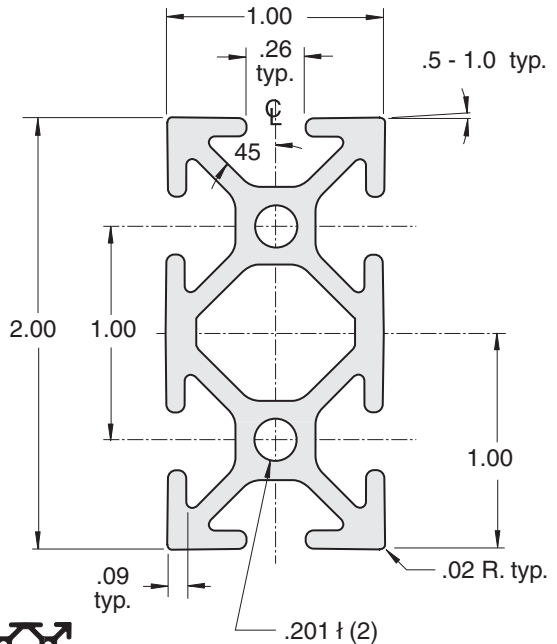

**Section Properties:**

Moment of Intertia in <sup>4</sup>	.316	.088
Section modulus in <sup>3</sup>	.316	.176

1/4" SLOTS

### EX-13

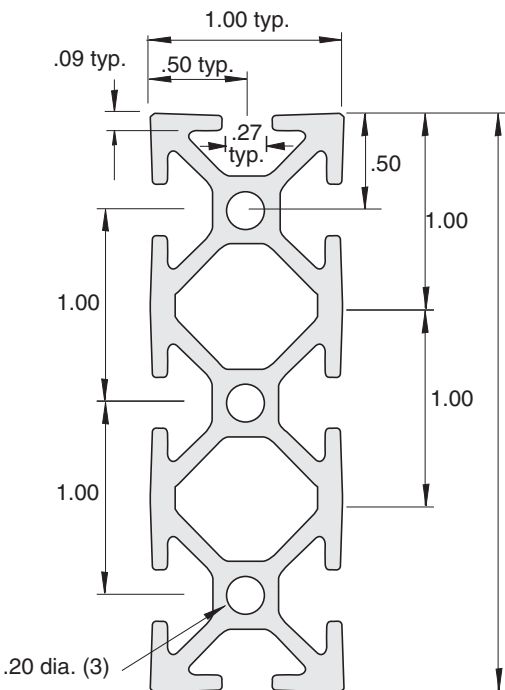

- Finish = Clear anodized
- Material = 6105-T5 Aluminum
- Est. Area = 1.162 Sq. In.
- Weight/ft = 1.367 lbs.
- 96", 192.63" Lengths standard.

**Section Properties:**

Moment of Inertia in <sup>4</sup>	1.376	0.387
Section modulus in <sup>3</sup>	0.917	0.516



### EX-22

- Finish = Clear anodized
- Material = 6105-T5 Aluminum
- Est. Area = .451 Sq. In.
- Weight/ft = 1.468 lbs.
- 96", 192.63" Lengths standard.

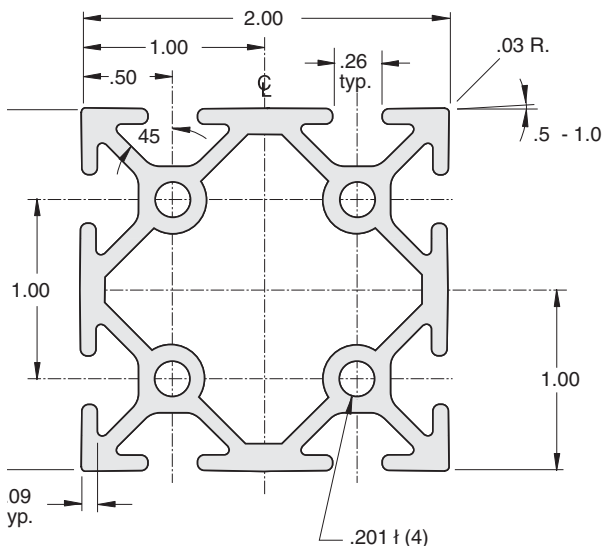

**1/4" SLOTS**

**Section Properties:**

Moment of Inertia in <sup>4</sup>	.49
Section modulus in <sup>3</sup>	.097

**EX-24**

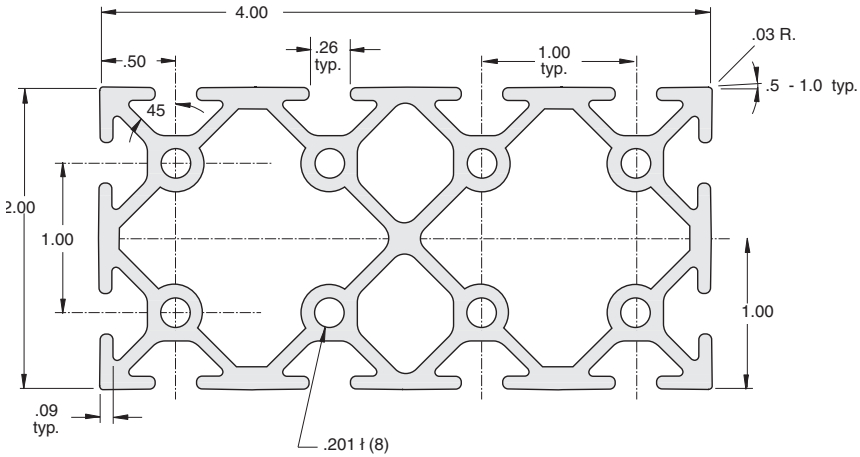

- Finish = Clear anodized
- Material = 6063-T6HT Aluminum
- Est. Area = 2.352 Sq. In.
- Weight/ft = 2.766 lbs.
- 96", 192.63" Lengths standard.

**Section Properties:**

Moment of Intertia in <sup>4</sup>	3.634	1.078
Section modulus in <sup>3</sup>	1.817	1.078

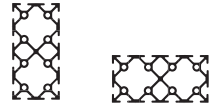

**EX-14**

**SMOOTH-Series**

1/4" SLOTS

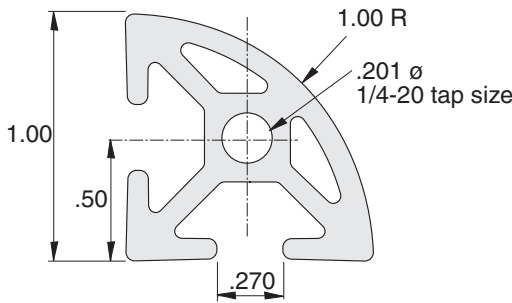

- Finish = Clear anodized
- Material = 6105-T6 Aluminum
- Est. Area = .438 Sq. In.
- Weight/ft = .515 lbs.
- 96", 192.63" Lengths standard.

**Section Properties:**

Moment of Intertia in <sup>4</sup>	.0368
Section modulus in <sup>3</sup>	.0675

### SMOOTH-Series

**EX-70**

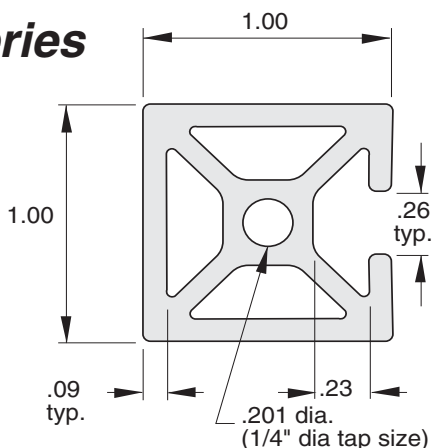

- Finish = Clear anodized
- Material = 6105-T5 Aluminum
- Est. Area = .451 Sq. In.
- Weight/ft = .576 lbs.
- 96", 192.63" Lengths standard.

#### Section Properties:

Moment of Inertia in <sup>4</sup>	.057	.052
Section modulus in <sup>3</sup>	.114	.099



### SMOOTH-Series

**EX-71**

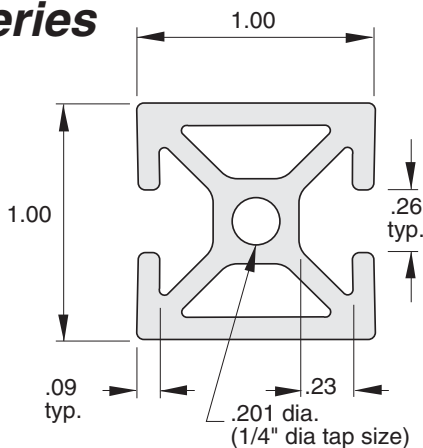

- Finish = Clear anodized
- Material = 6105-T5 Aluminum
- Est. Area = .451 Sq. In.
- Weight/ft = .550 lbs.
- 96", 192.63" Lengths standard.

#### Section Properties:

Moment of Inertia in <sup>4</sup>	.057	.046
Section modulus in <sup>3</sup>	.114	.093



**EX-72**

**SMOOTH-Series**

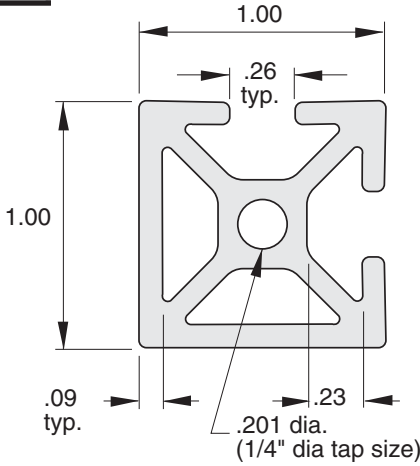

- Finish = Clear anodized
- Material = 6105-T5 Aluminum
- Est. Area = .451 Sq. In.
- Weight/ft = .546 lbs.
- 96", 192.63" Lengths standard.

**Section Properties:**

Moment of Intertia in <sup>4</sup>	.051
Section modulus in <sup>3</sup>	.098

**EX-73**

**SMOOTH-Series**

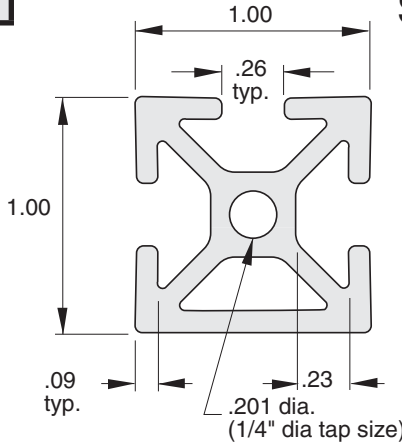

- Finish = Clear anodized
- Material = 6105-T5 Aluminum
- Est. Area = .451 Sq. In.
- Weight/ft = .523 lbs.
- 96", 192.63" Lengths standard.

**Section Properties:**

Moment of Intertia in <sup>4</sup>	.051	.046
Section modulus in <sup>3</sup>	.099	.092



1/4" SLOTS

## Section F.1 Corner Angle Brackets

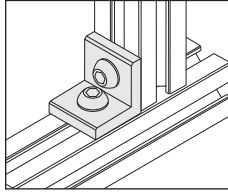

page 350

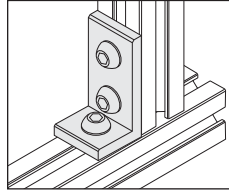

page 351

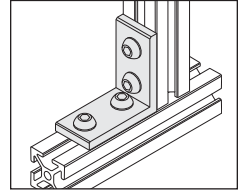

page 352

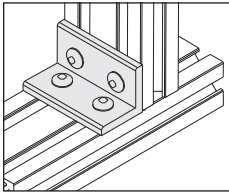

page 353

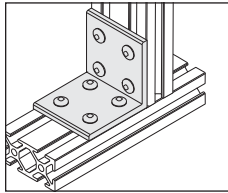

page 354

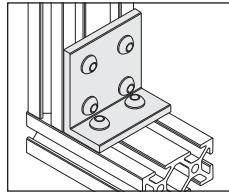

page 355

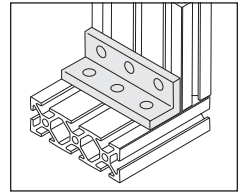

page 356

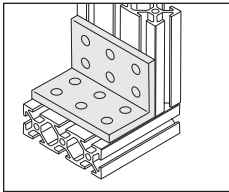

page 357

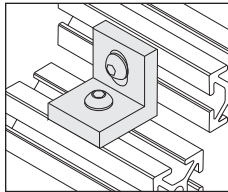

page 358

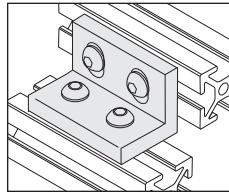

page 359

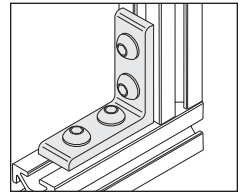

page 360

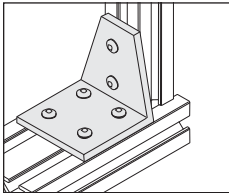

page 361

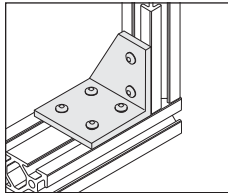

page 362

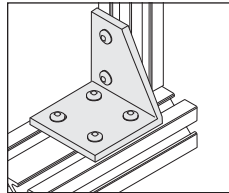

page 363

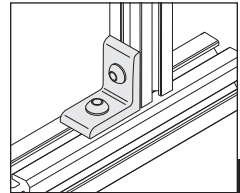

page 364

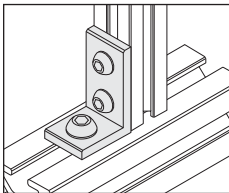

page 365

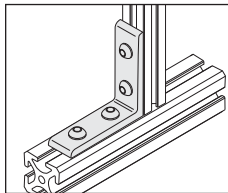

page 366

## Section F.2

### Gusseted Corner Angle Brackets

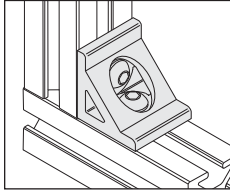

page 367

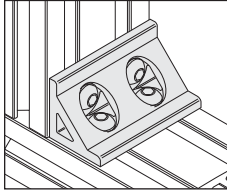

page 368

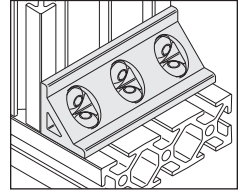

page 369

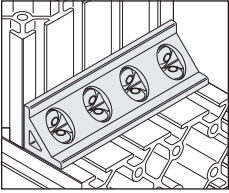

page 370

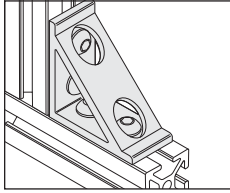

page 371

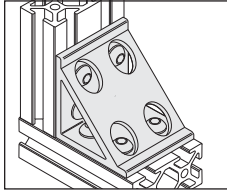

page 372

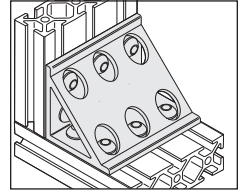

page 373

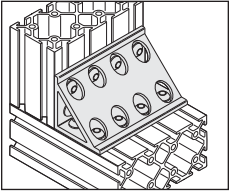

page 374

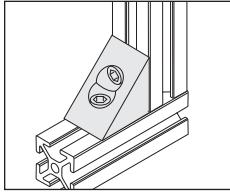

page 375

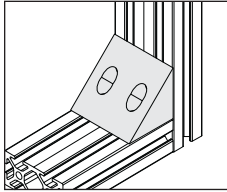

page 376

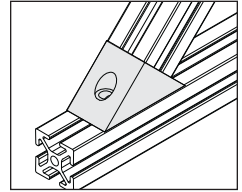

page 377

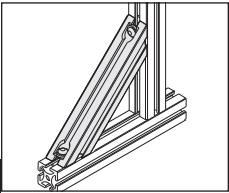

page 378

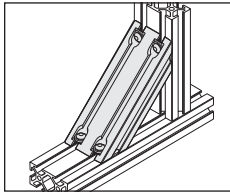

page 379

## Section F.3

### Steel Corner Angle Brackets

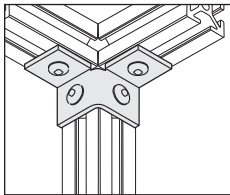

page 380

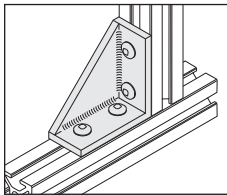

page 381

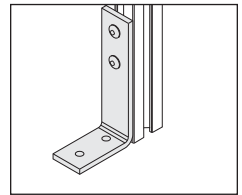

page 382

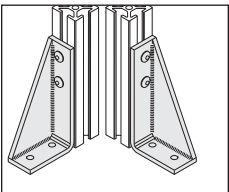

page 383

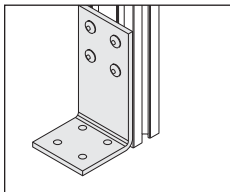

page 384

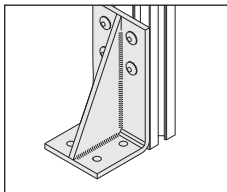

page 385

## Section F.4

### Internal & Adjustable Corner Brackets

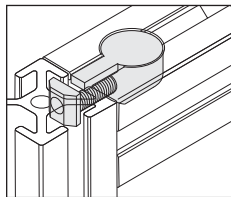

page 386

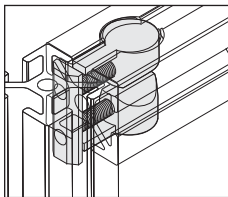

page 387

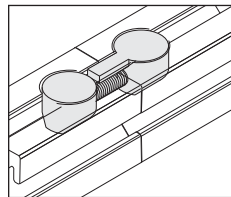

page 388

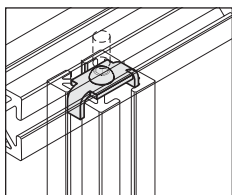

page 389

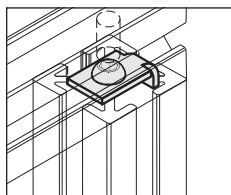

page 389

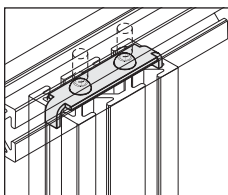

page 390

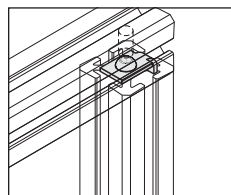

page 391

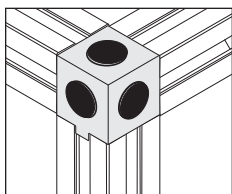

page 392

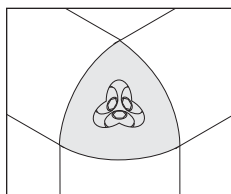

page 393

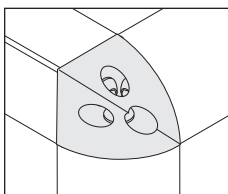

page 394

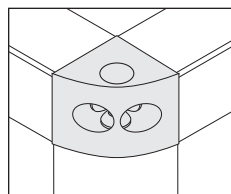

page 395

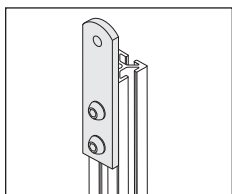

page 396

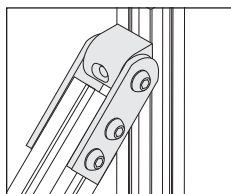

page 397

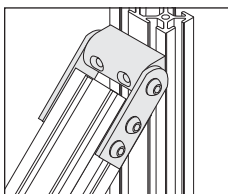

page 398

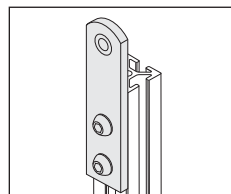

page 399

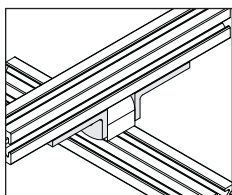

page 400

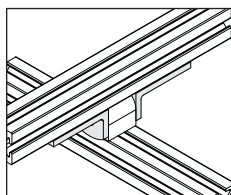

page 401

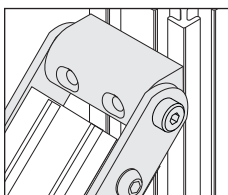

page 402

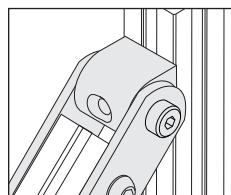

page 403

## Section F.5

### Joining Plates

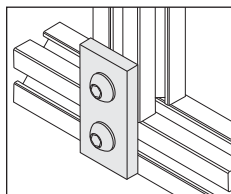

page 404

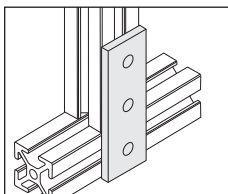

page 405

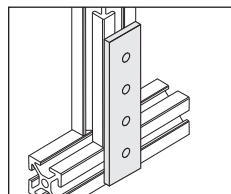

page 406

1/4" SLOTS



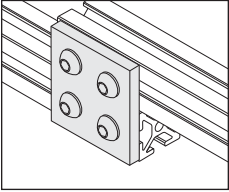

page 407

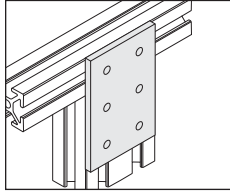

page 408

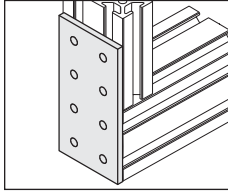

page 409

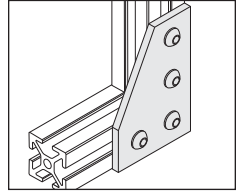

page 410

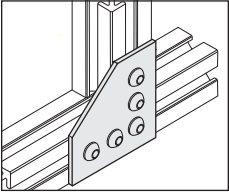

page 411

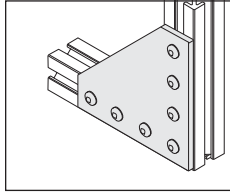

page 412

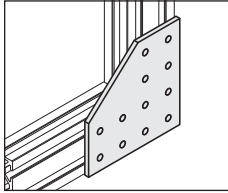

page 413

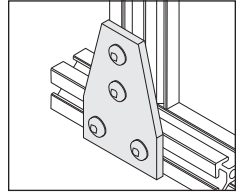

page 414

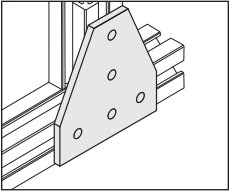

page 415

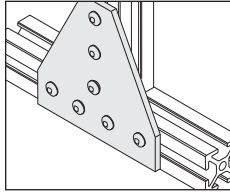

page 416

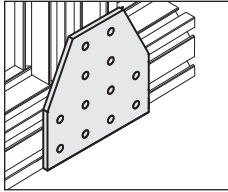

page 417

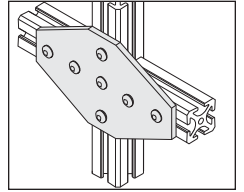

page 418

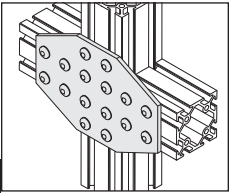

page 419

**Section F.6**  
**Floor Mounts,**  
**Casters and**  
**Adjustable**  
**Feet**

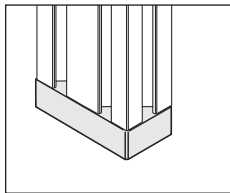

page 420

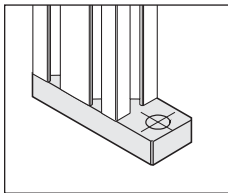

page 421

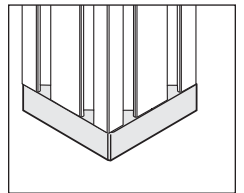

page 422

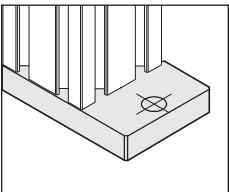

page 423

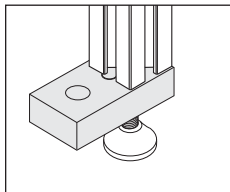

page 424

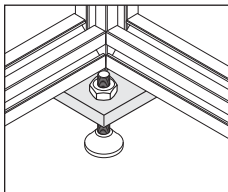

page 425

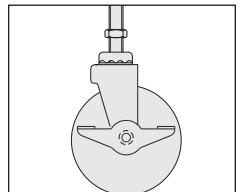

page 426

1/4" SLOTS

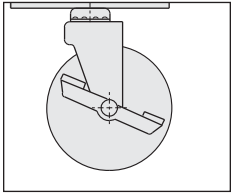

page 427

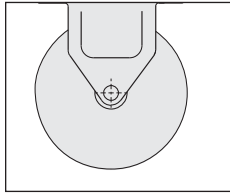

page 428

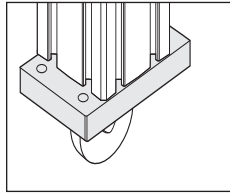

page 429

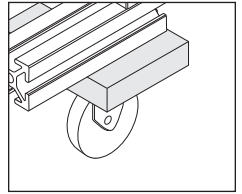

page 430

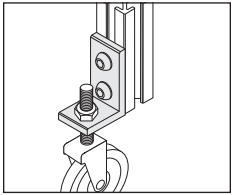

page 431

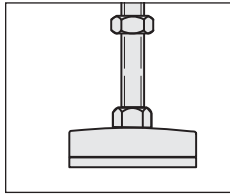

page 432

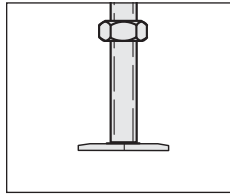

page 432

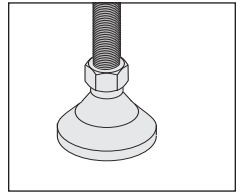

page 432

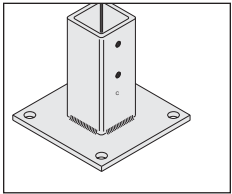

page 433

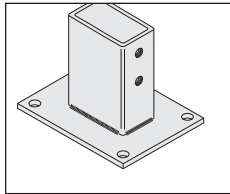

page 434

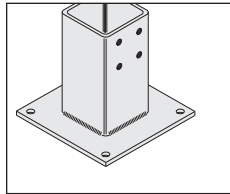

page 435

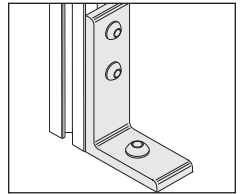

page 436

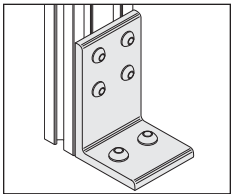

page 437

## Section F.7 Panels, Doors and Hardware

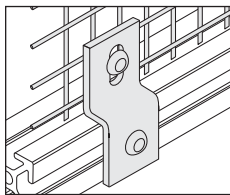

page 438

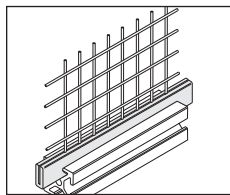

page 439

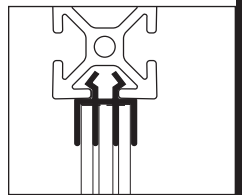

page 440

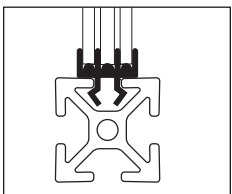

page 440

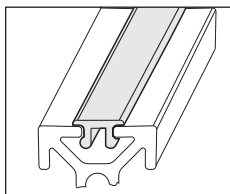

page 441

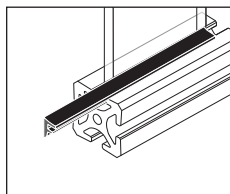

page 442

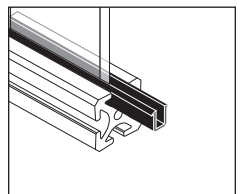

page 443

1/4" SLOTS

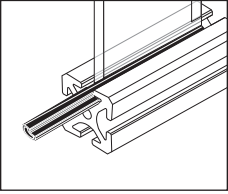

page 444

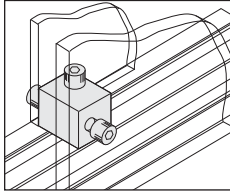

page 445

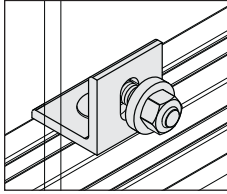

page 446

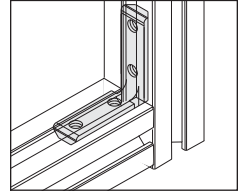

page 447

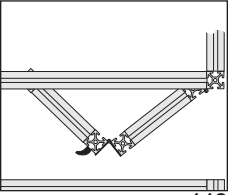

page 448

## Section F.8

### Hinges, Handles and Latches

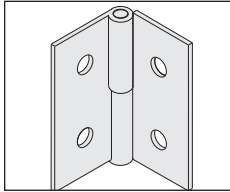

page 449

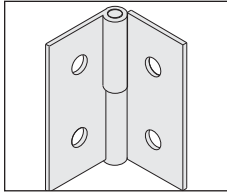

page 450

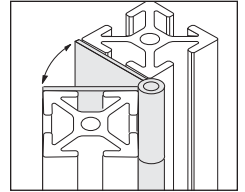

page 451

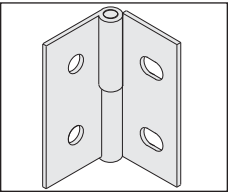

page 452

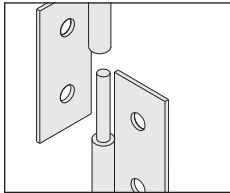

page 453

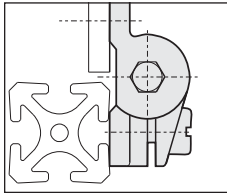

page 454

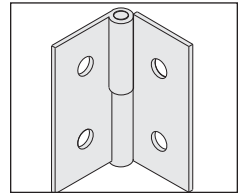

page 455

1/4" SLOTS

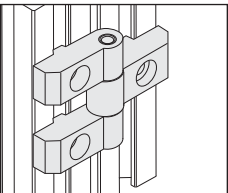

page 456

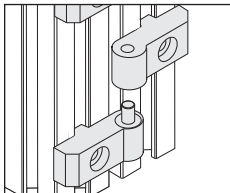

page 457

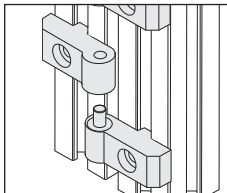

page 458

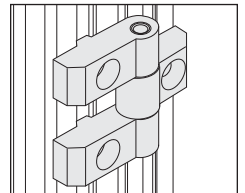

page 459

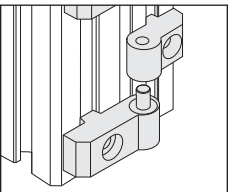

page 460

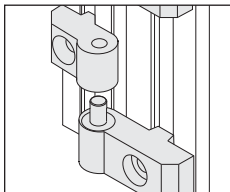

page 461

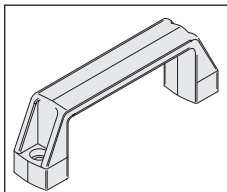

page 462

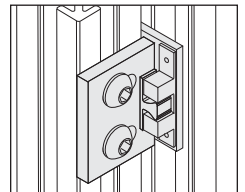

page 463

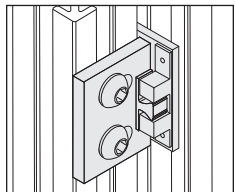

page 464

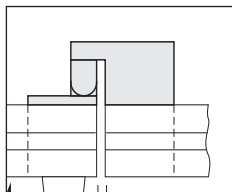

page 465

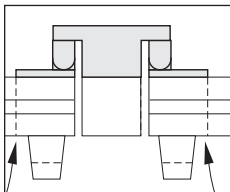

page 465

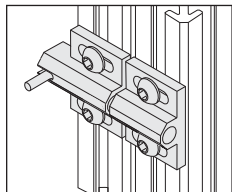

page 466

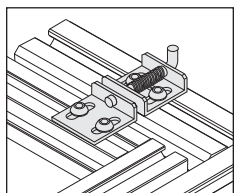

page 467

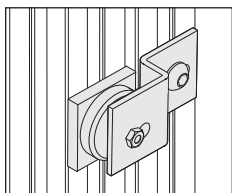

page 468

## Section F.9

### Sliding Components and Bearings

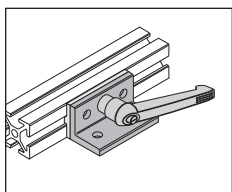

page 469

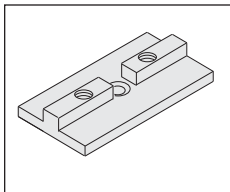

page 470

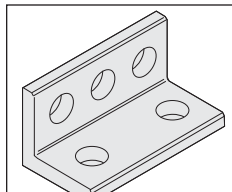

page 471

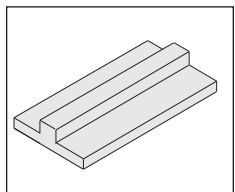

page 472

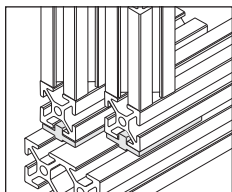

page 473

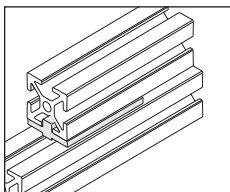

page 474

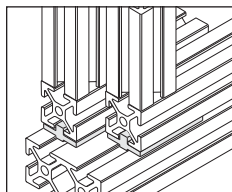

page 475

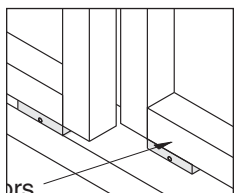

page 476

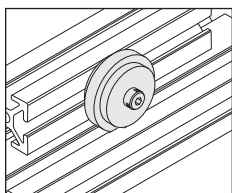

page 477

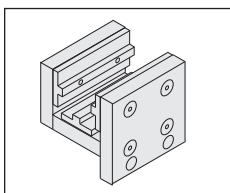

page 478

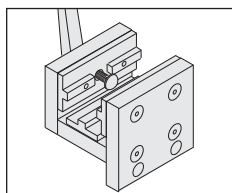

page 479

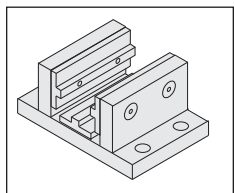

page 480

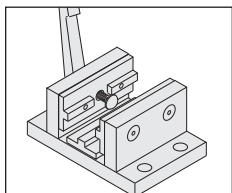

page 481

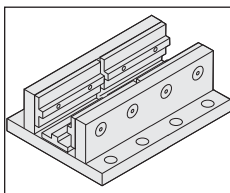

page 482

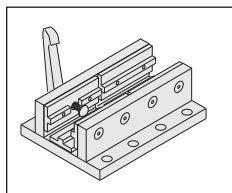

page 483

1/4" SLOTS

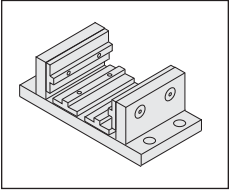

page 484

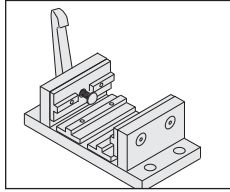

page 485

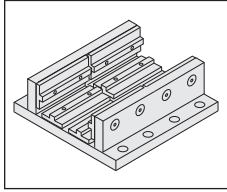

page 486

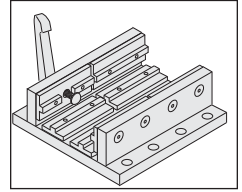

page 487

**Section E.10  
Stanchions**

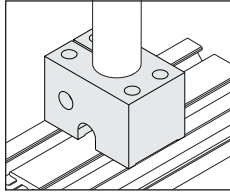

page 488

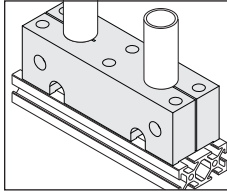

page 489

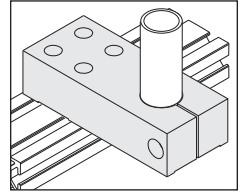

page 490

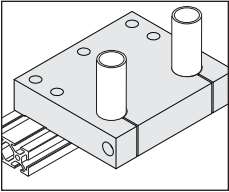

page 491

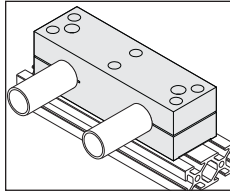

page 492

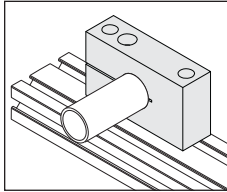

page 493

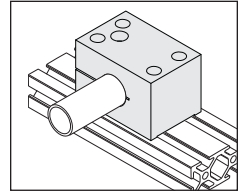

page 494

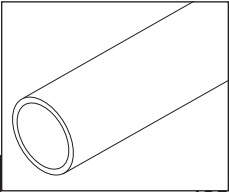

page 495

**1/4" SLOTS**

**Section E.10  
Screws, Nuts  
& Fasteners**

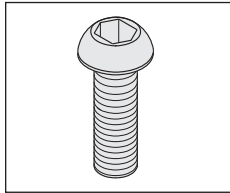

page 496

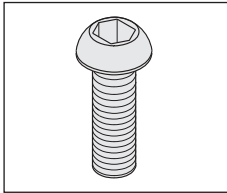

page 497

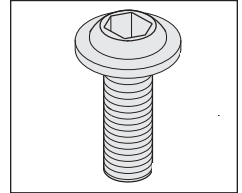

page 497

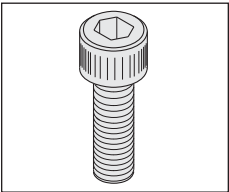

page 498

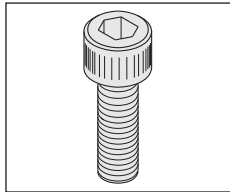

page 499

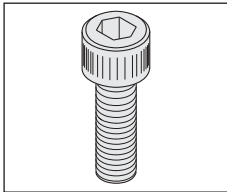

page 500

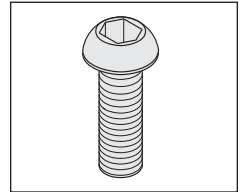

page 500

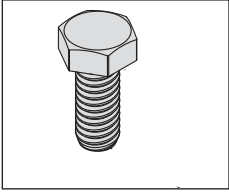

page 501

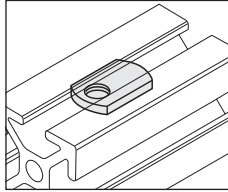

page 502

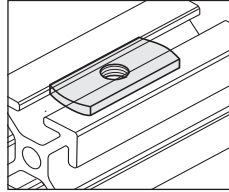

page 503

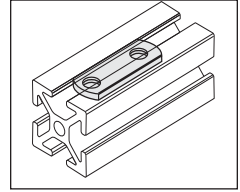

page 504

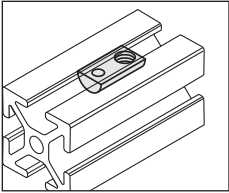

page 505

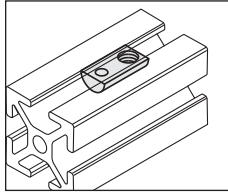

page 506

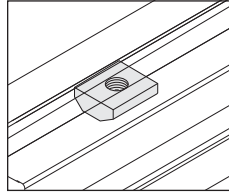

page 507

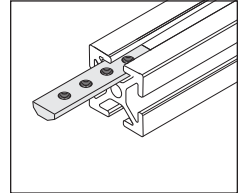

page 508

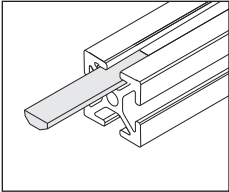

page 509

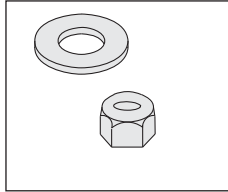

page 510

## Section E.11 Miscellaneous Components

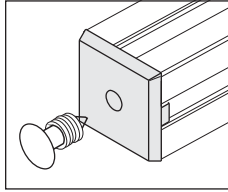

page 511

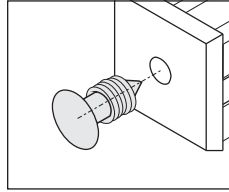

page 512

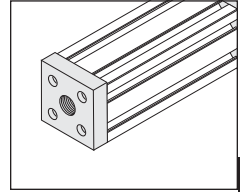

page 513

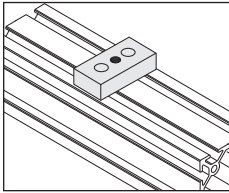

page 514

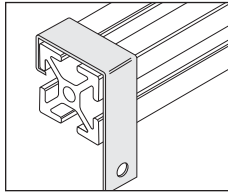

page 515

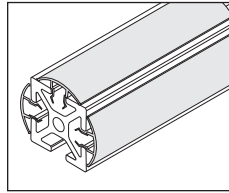

page 516

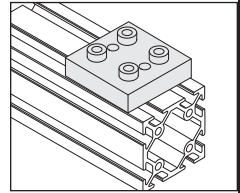

page 517

1/4" SLOTS

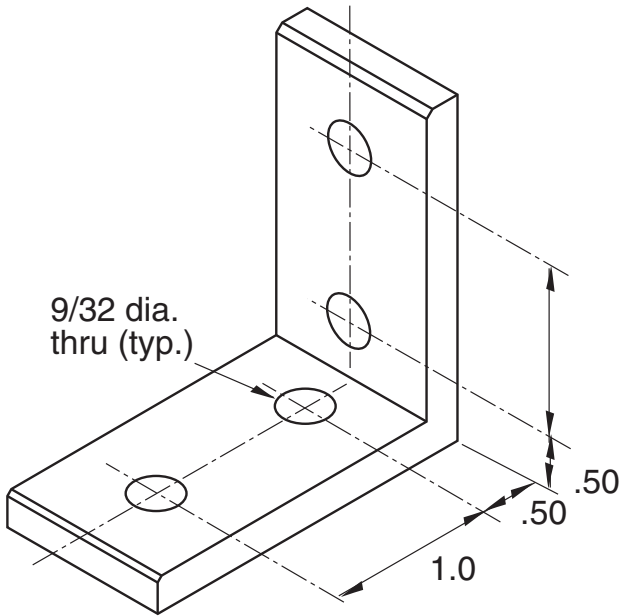

Mounting brackets and plates are made from clear anodized aluminum unless specified.

Mounting and connecting brackets have 9/32" diameter clearance holes which are on .50" or 1.00" centers.

Any deviations are specified.

**Recommended torque for fasteners is 12-17 ft lbs.**

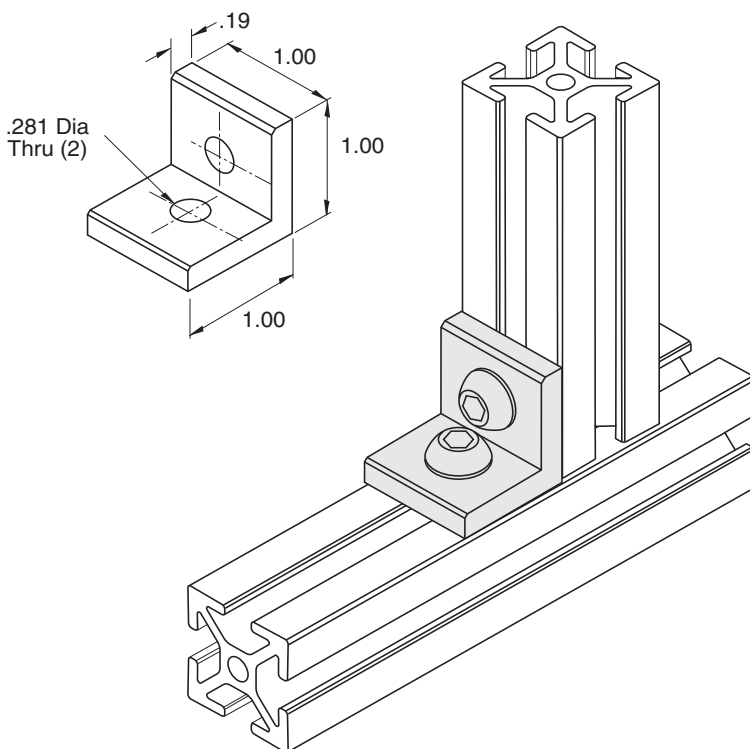

Recommended Hardware  
(2) 11-231 BHCS  
(2) 11-210 T-nut

Material - Aluminum  
Finish - Clear Anodize

1/4" SLOTS



**11-2**

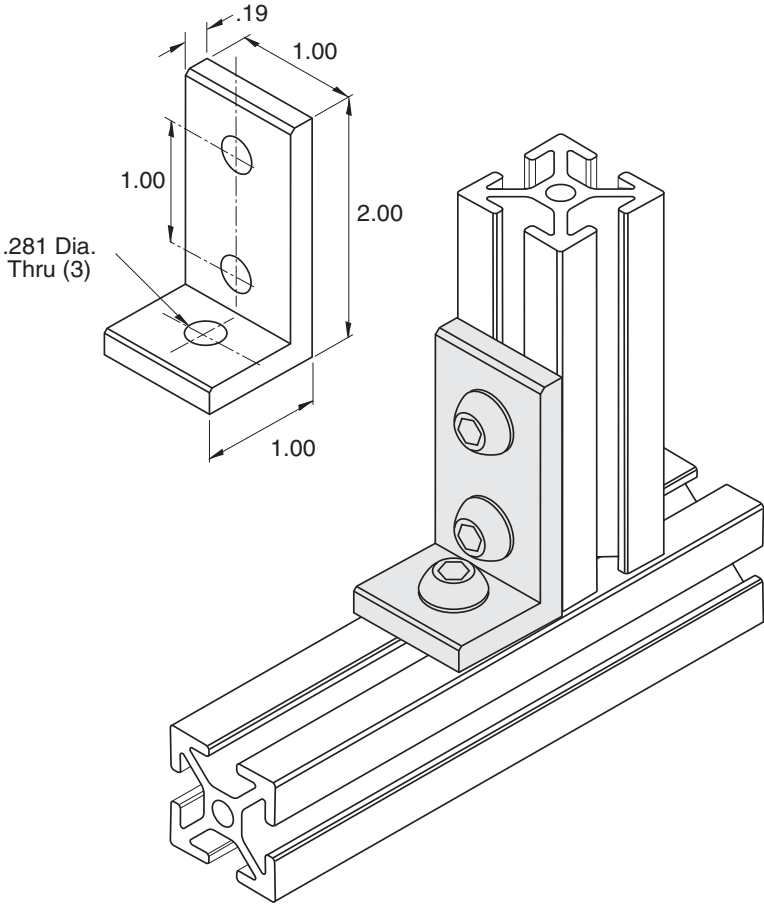

**1/4" SLOTS**

Recommended Hardware  
(3) 11-231 BHCS  
(3) 11-210 T-nut

Material - Aluminum  
Finish - Clear Anodize

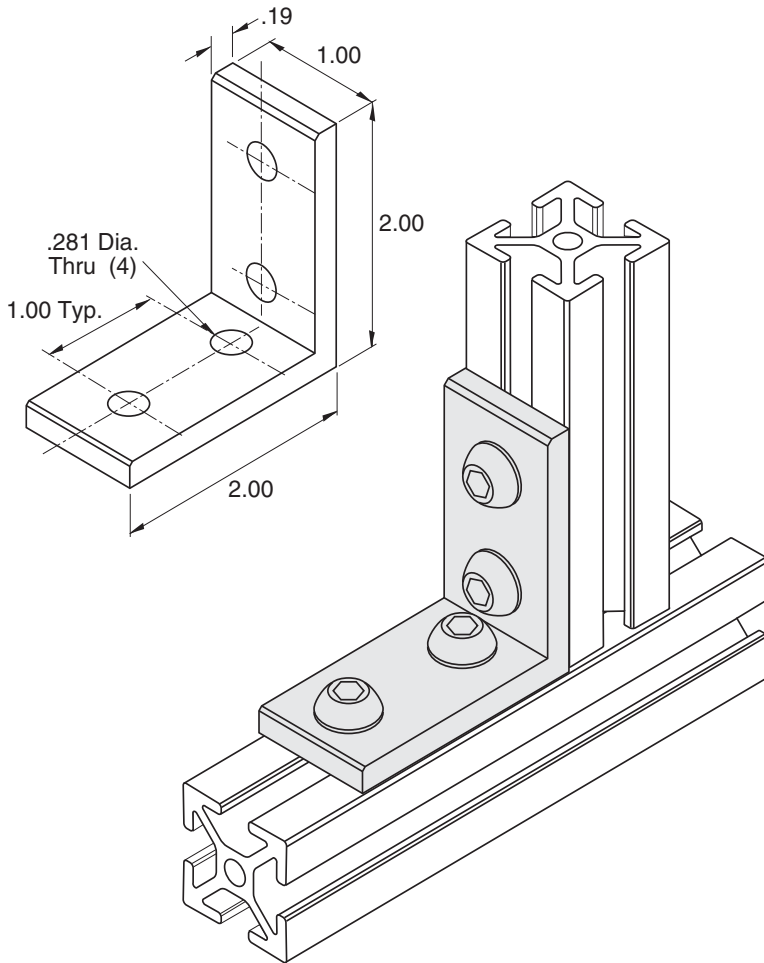

Recommended Hardware  
(4) 11-231 BHCS  
(4) 11-210 T-nut

**1/4" SLOTS**

Material - Aluminum  
Finish - Clear Anodize

**11-4**

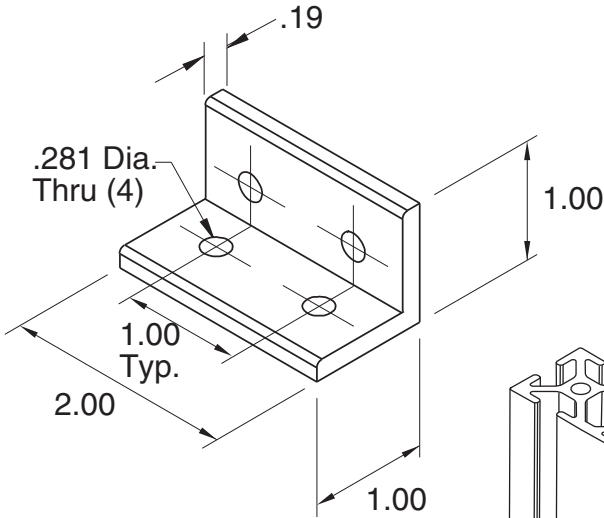

Recommended Hardware  
(4) 11-231 BHCS  
(4) 11-210 T-nut

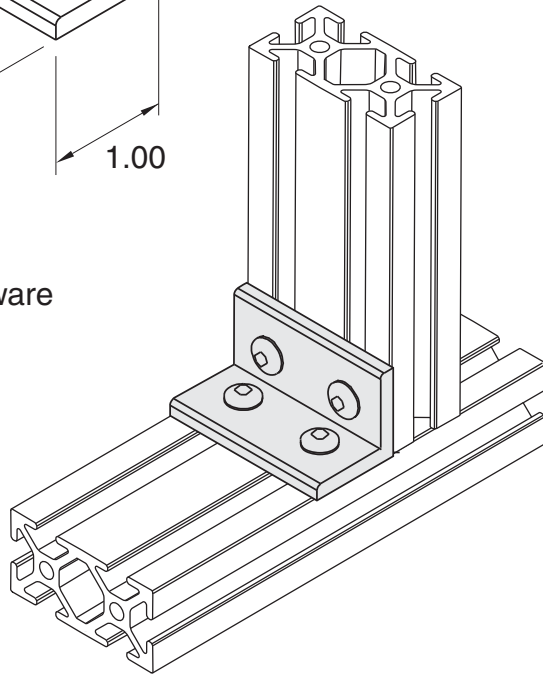

1/4" SLOTS

Material - Aluminum  
Finish - Clear Anodize

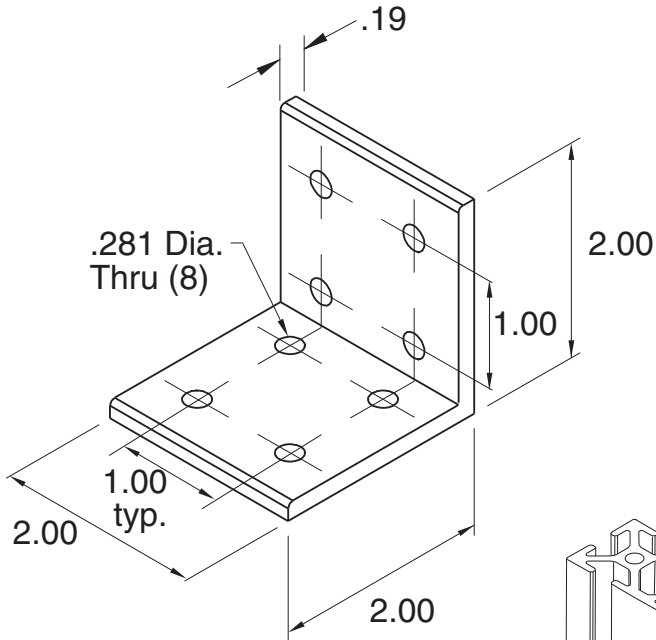

Recommended Hardware  
(8) 11-231 BHCS  
(8) 11-210 T-nut

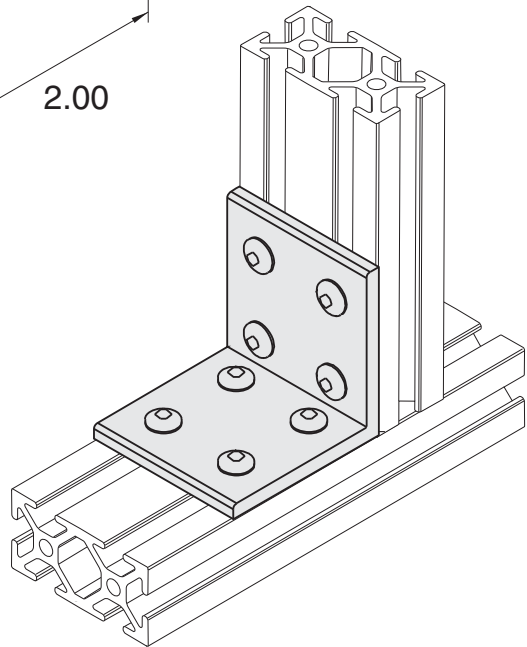

Material - Aluminum  
Finish - Clear Anodize

**11-80**

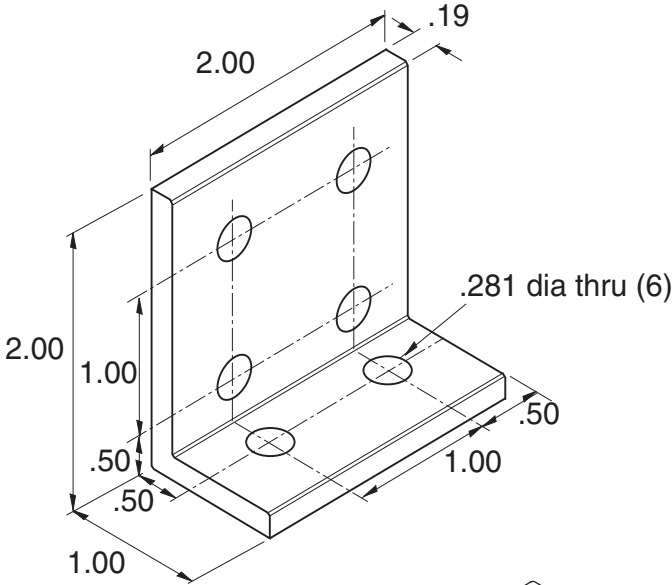

Recommended Hardware  
(6) 11-231 BHCS  
(6) 11-210 T-nut

**1/4" SLOTS**

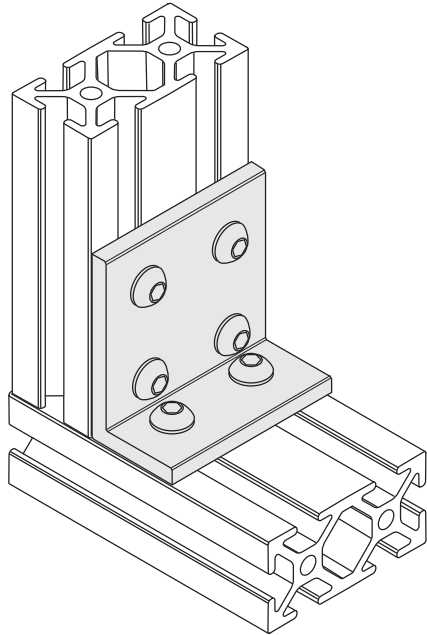

Material - Aluminum  
Finish - Clear Anodize

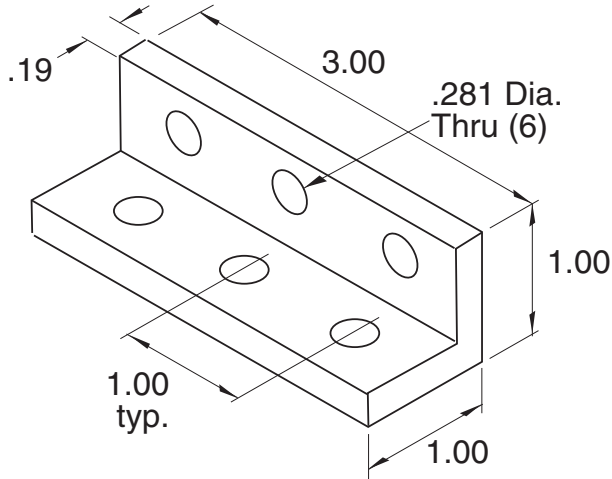

Recommended  
Hardware  
(6) 11-231 BHCS  
(6) 11-210 T-nut

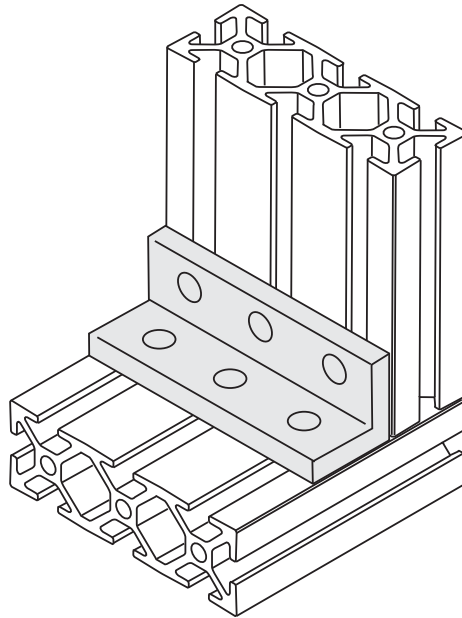

Material - Aluminum  
Finish - Clear Anodize

**11-14**

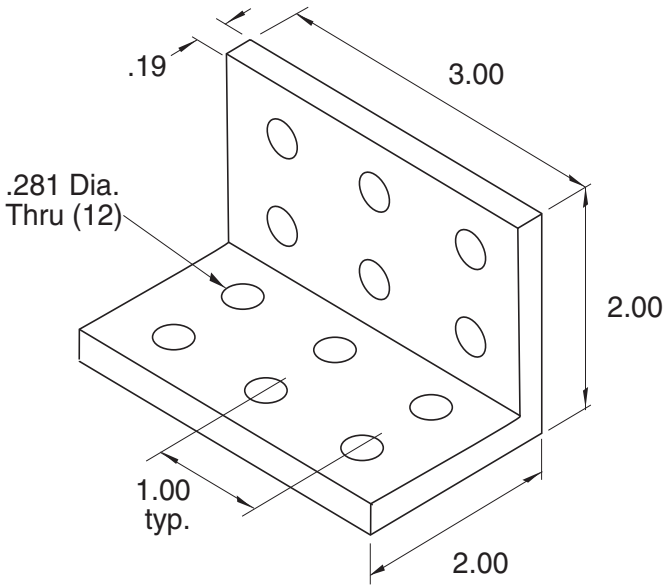

Recommended Hardware  
(12) 11-231 BHCS  
(12) 11-210 T-nut

**1/4" SLOTS**

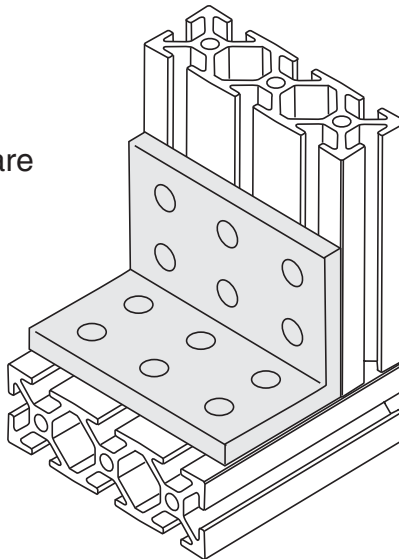

Material - Aluminum  
Finish - Clear Anodize

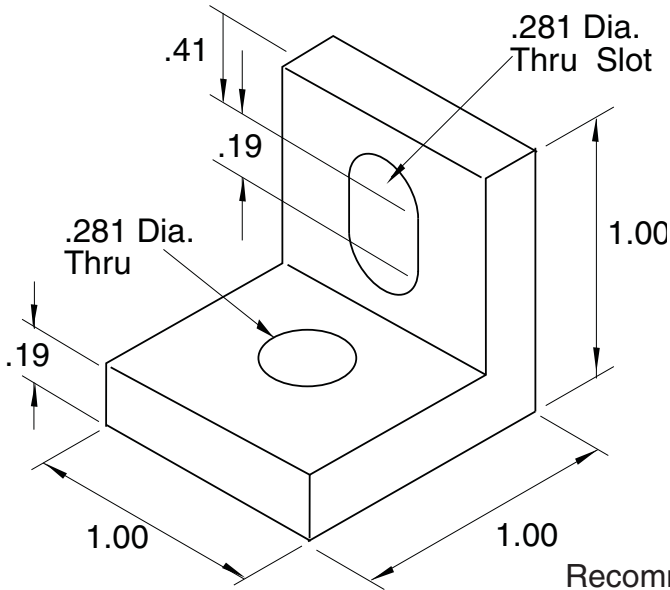

Recommended  
Hardware  
(2) 11-231 BHCS  
(2) 11-210 T-nut

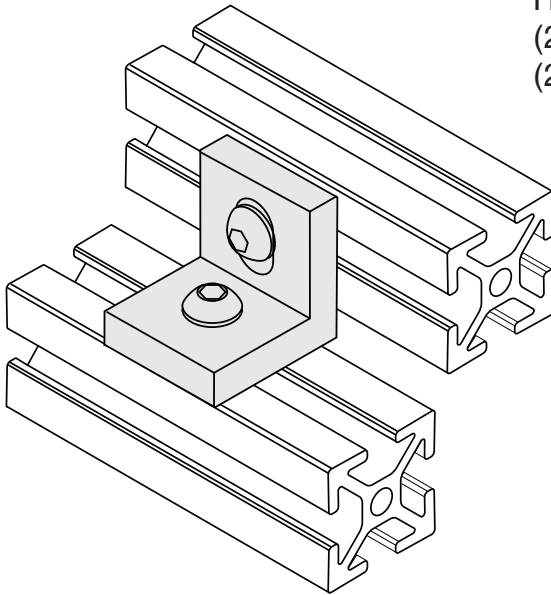

**1/4" SLOTS**

Material - Aluminum  
Finish - Clear Anodize



# Slotted Corner Angle



**11-16**

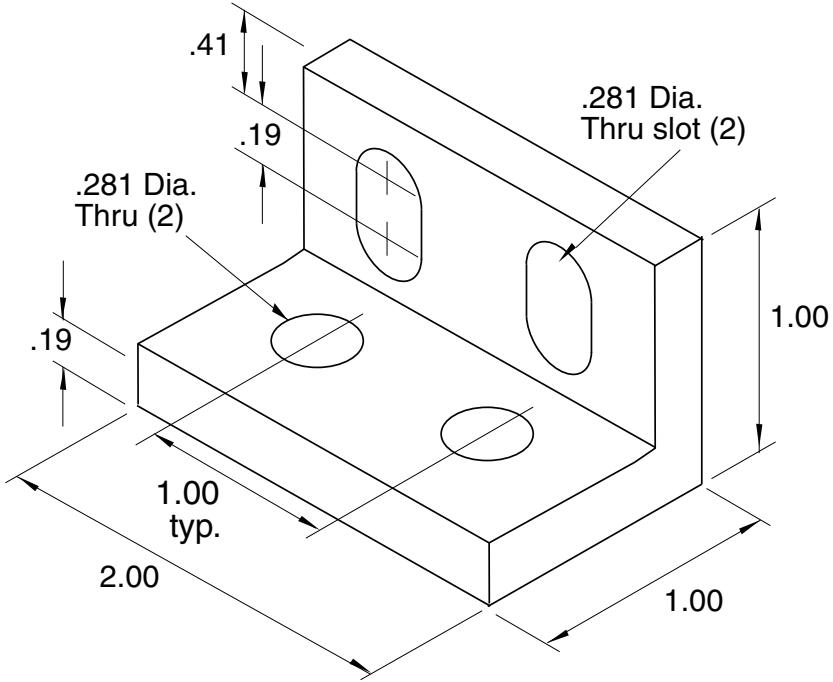

Recommended Hardware  
(4) 11-231 BHCS  
(4) 11-210 T-nut

1/4" SLOTS

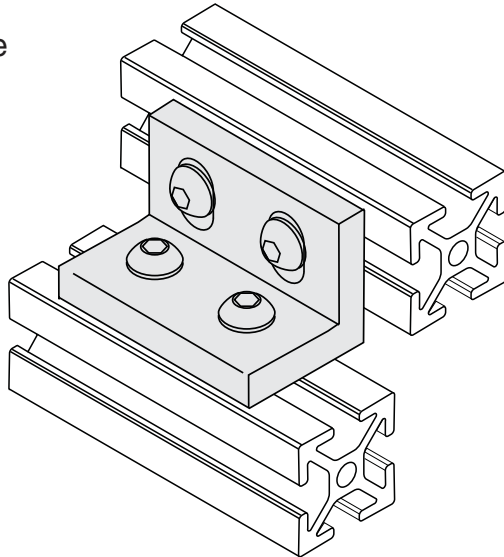

Material - Aluminum  
Finish - Clear Anodize

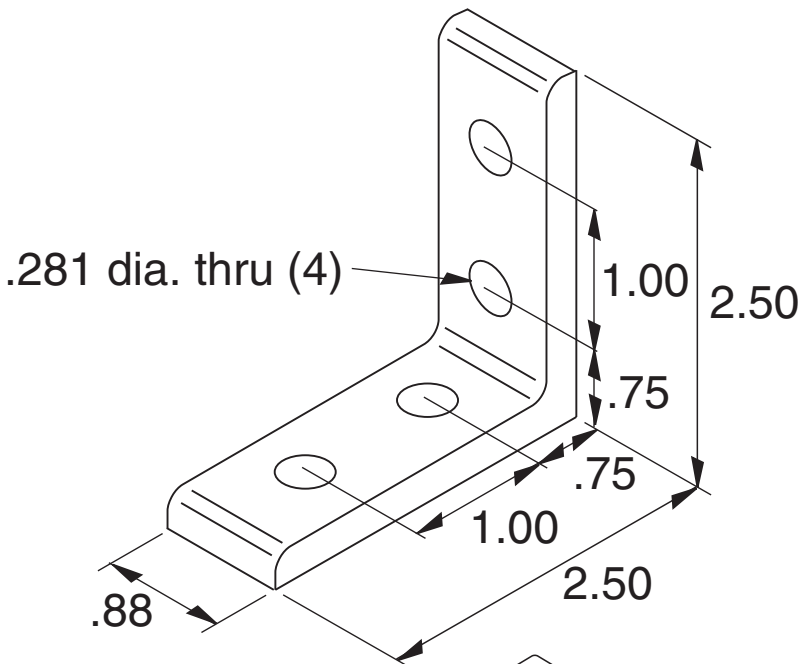

Recommended Hardware  
(4) 11-231 BHCS  
(4) 11-210 T-nut

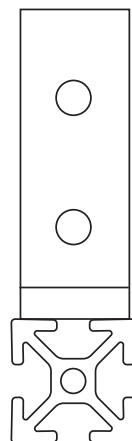
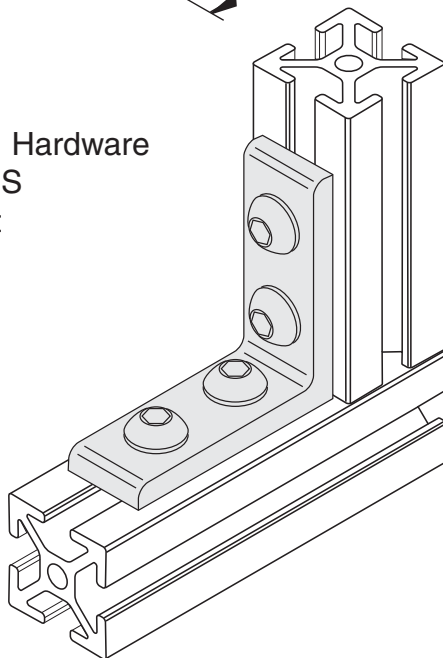

**1/4" SLOTS**

Material - Aluminum  
Finish - Clear Anodize

**11-17**

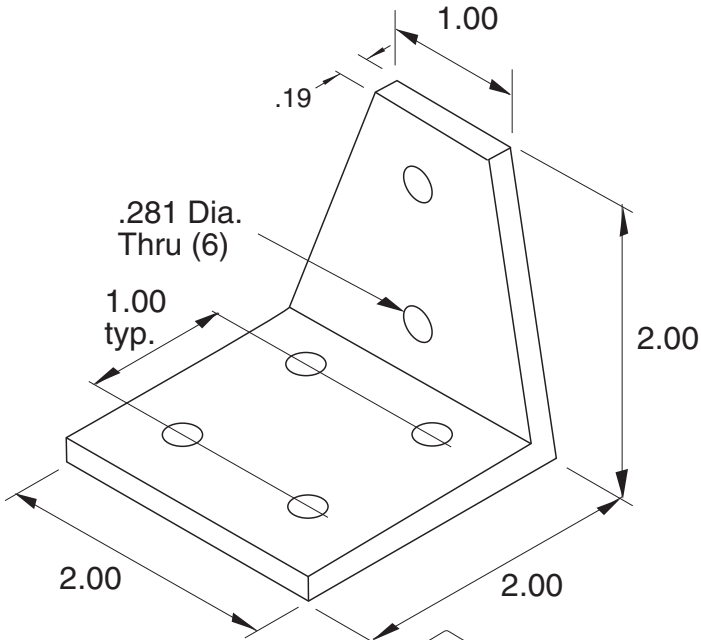

Recommended Hardware  
(6) 11-231 BHCS  
(6) 11-210 T-nut

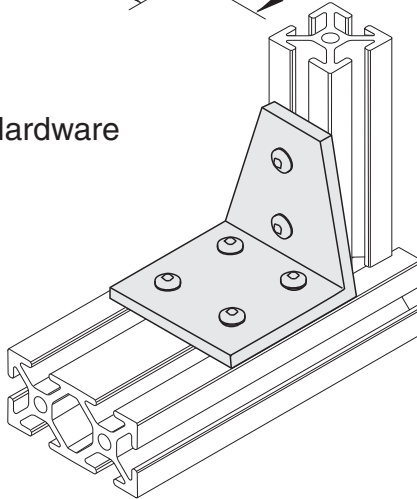

**1/4" SLOTS**

Material - Aluminum  
Finish - Clear Anodize

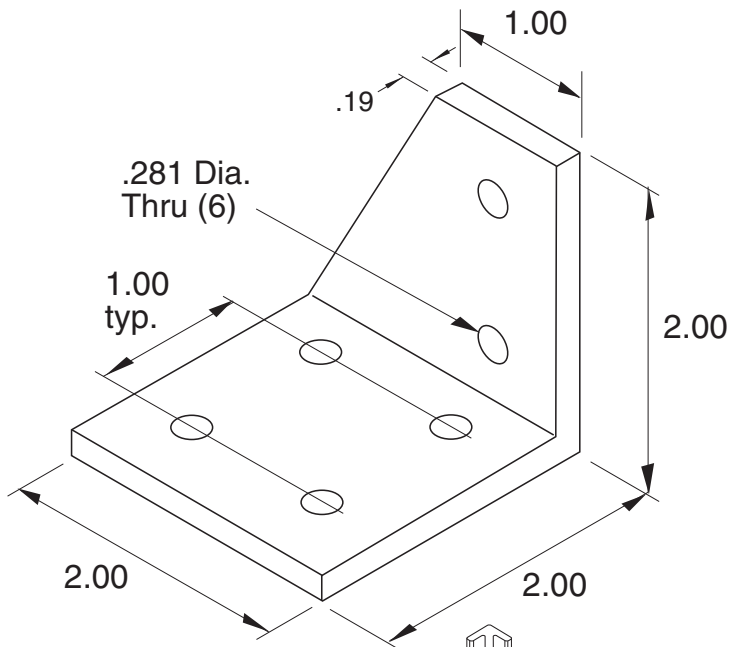

Recommended  
Hardware  
(6) 11-231 BHCS  
(6) 11-210 T-nut

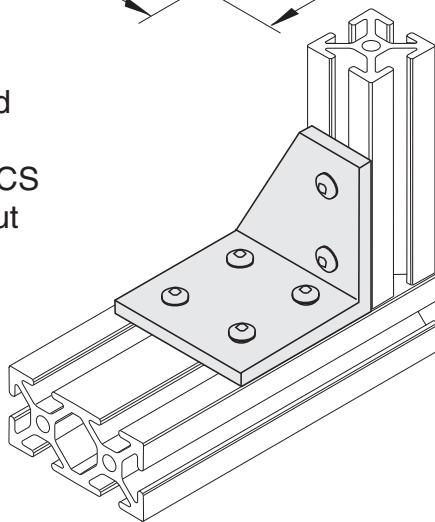

**1/4" SLOTS**

**Material - Aluminum  
Finish - Clear Anodize**

**11-37**

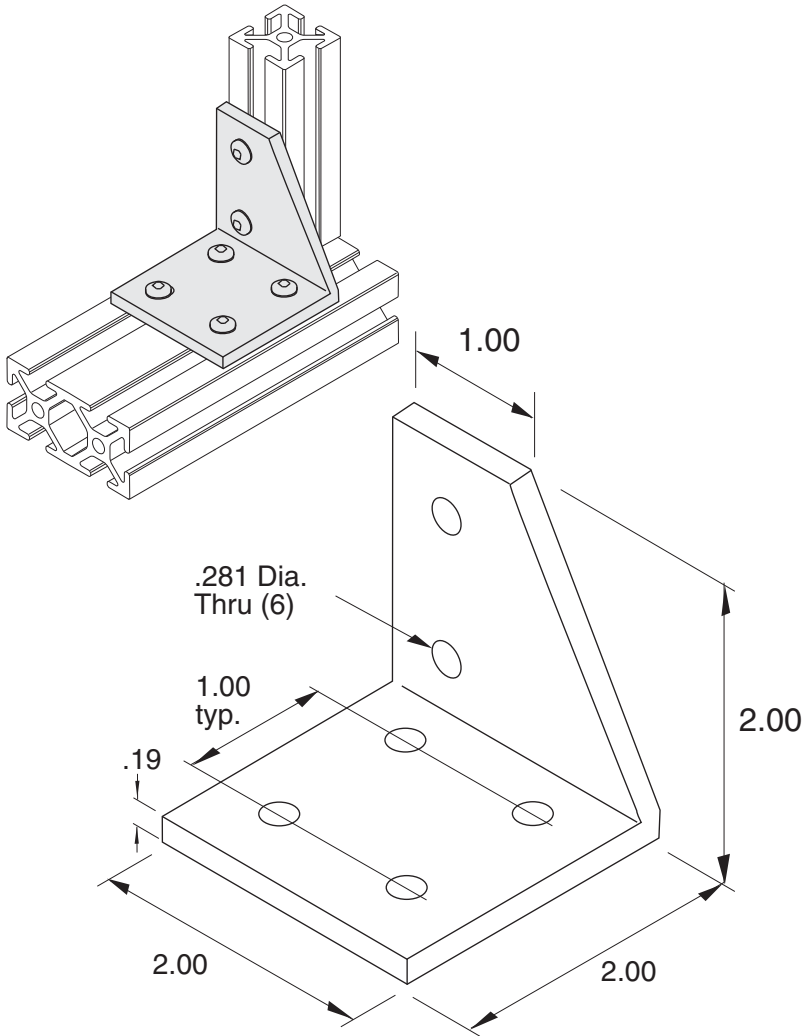

**1/4" SLOTS**

Recommended  
Hardware  
(6) 11-231 BHCS  
(6) 11-210 T-nut

Material - Aluminum  
Finish - Clear Anodize

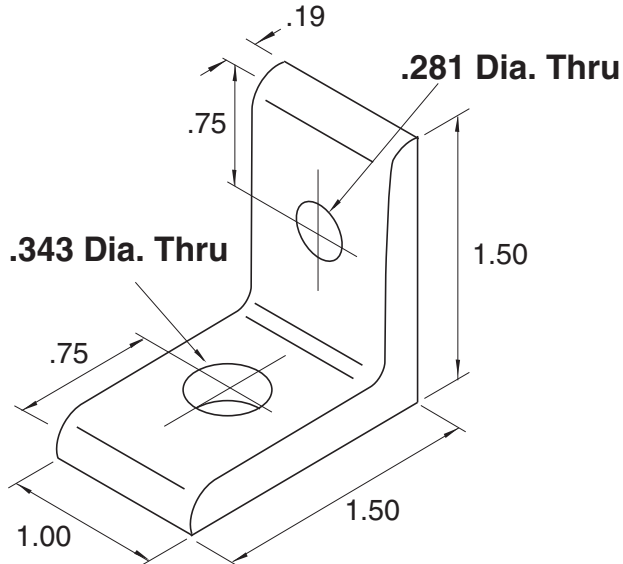
**.33 wide slot to .27 wide slot****11-53****Recommended  
Hardware**

- (1) 11-231 BHCS
- (1) EF-12-.63 BHCS
- (1) 11-210 T-nut
- (1) EF-2 T-nut

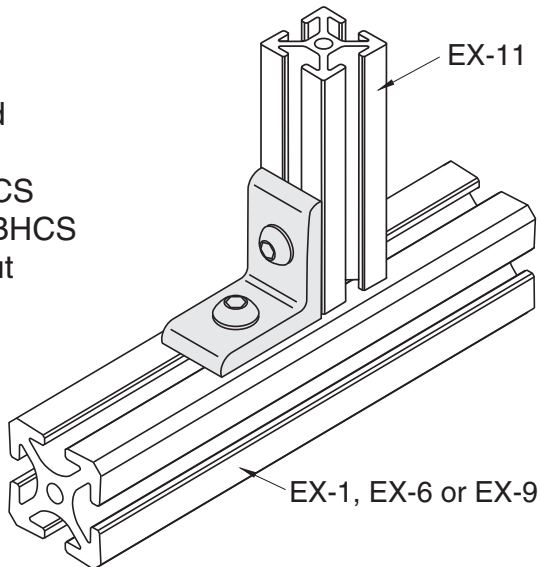
**1/4" SLOTS**

**Material - Aluminum**  
**Finish - Clear Anodize**

# Transition Corner Angle



## 11-5

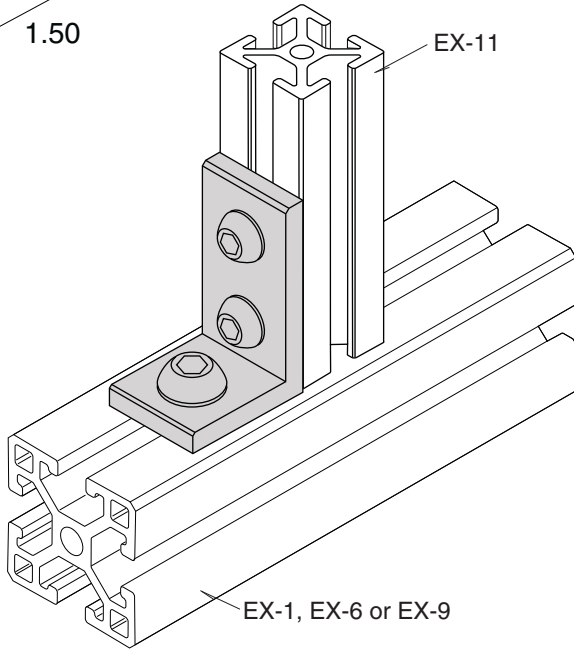
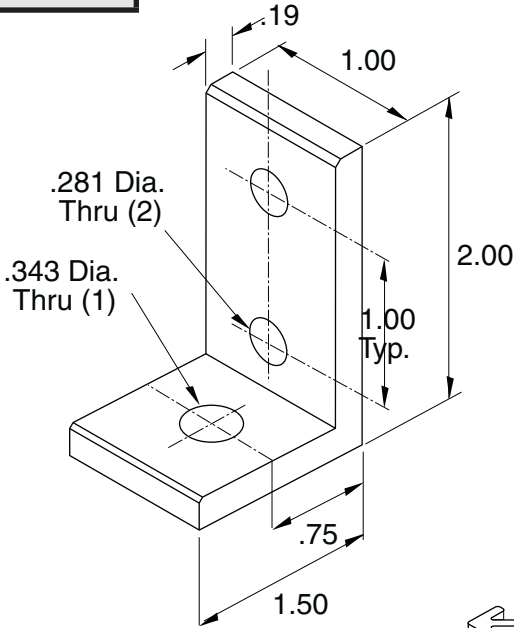

1/4" SLOTS

Recommended Hardware

- (2) 11-231 BHCS
- (2) 11-210 T-nut
- (1) EF-12-.63 BHCS
- (1) EF-2 T-nut

Material - Aluminum  
Finish - Clear Anodize

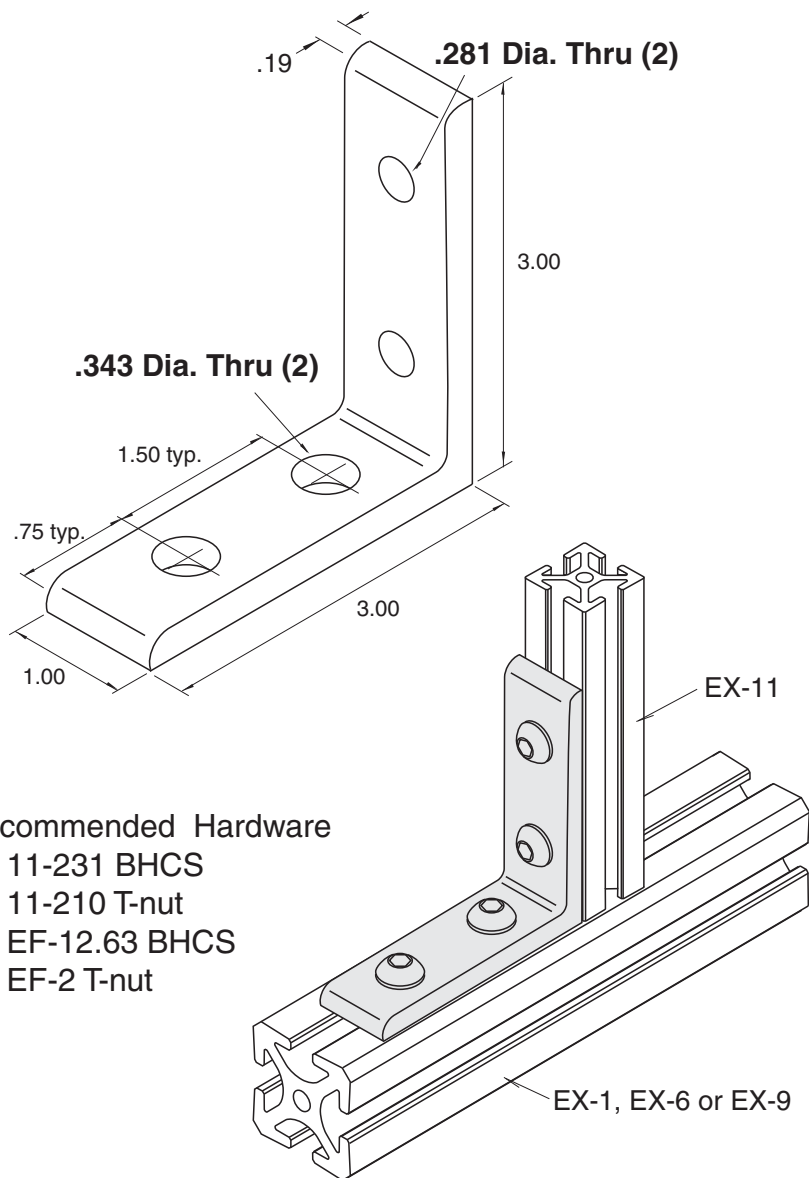
**.33 wide slot to .27 wide slot****11-54****Recommended Hardware**

- (2) 11-231 BHCS
- (2) 11-210 T-nut
- (2) EF-12.63 BHCS
- (2) EF-2 T-nut

**Material - Aluminum**  
**Finish - Clear Anodize**

**1/4" SLOTS**



**11-160**

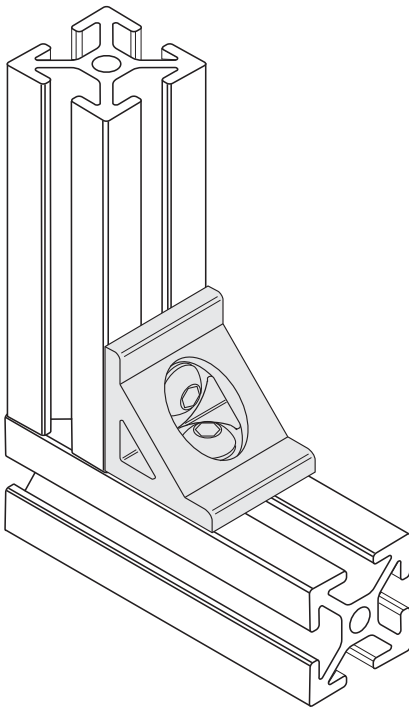
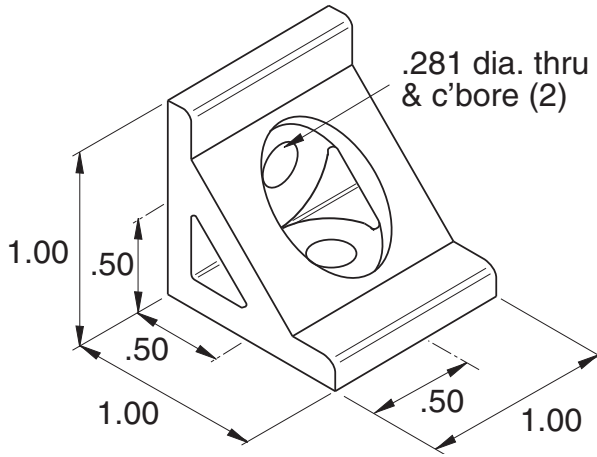

Recommended  
Hardware  
(2) 11-231 BHCS  
(2) 11-210 T-nut

**1/4" SLOTS**

Material - Aluminum  
Finish - Clear Anodize

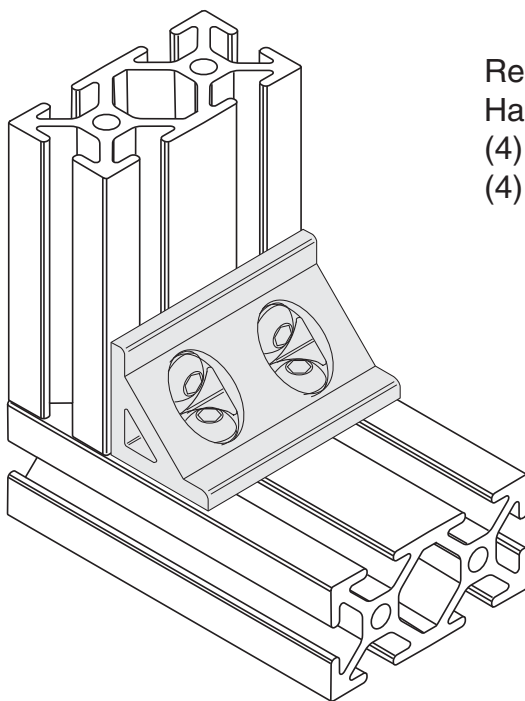
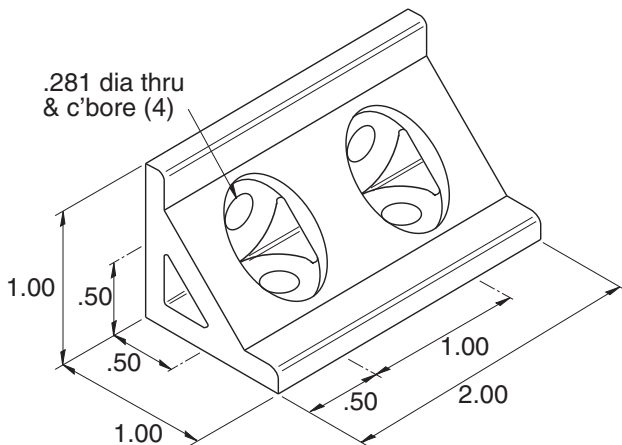

Recommended  
Hardware  
(4) 11-231 BHCS  
(4) 11-210 T-nut

Material - Aluminum  
Finish - Clear Anodize

**1/4" SLOTS**

**11-162**

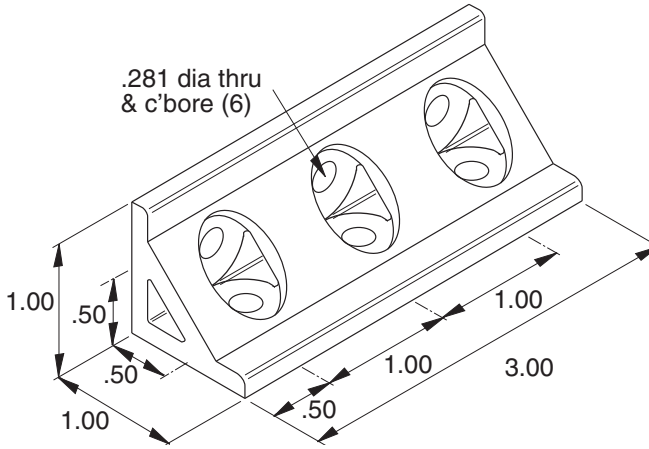

Recommended  
Hardware  
(6) 11-231 BHCS  
(6) 11-210 T-nut

**1/4" SLOTS**

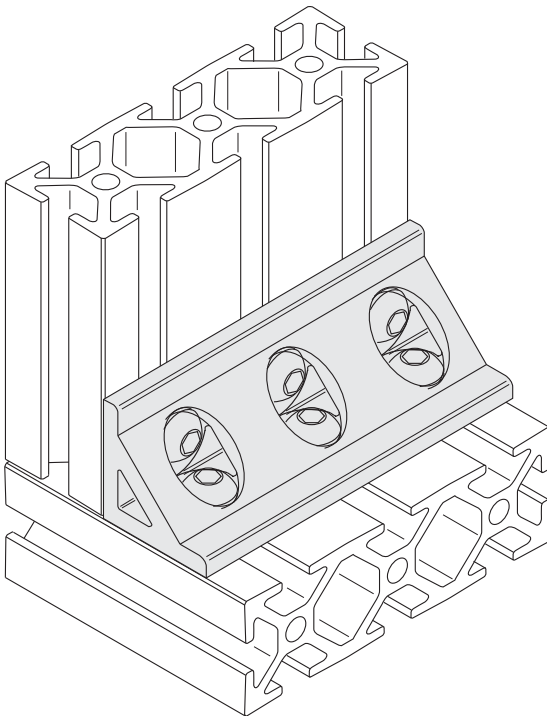

Material - Aluminum  
Finish - Clear Anodize

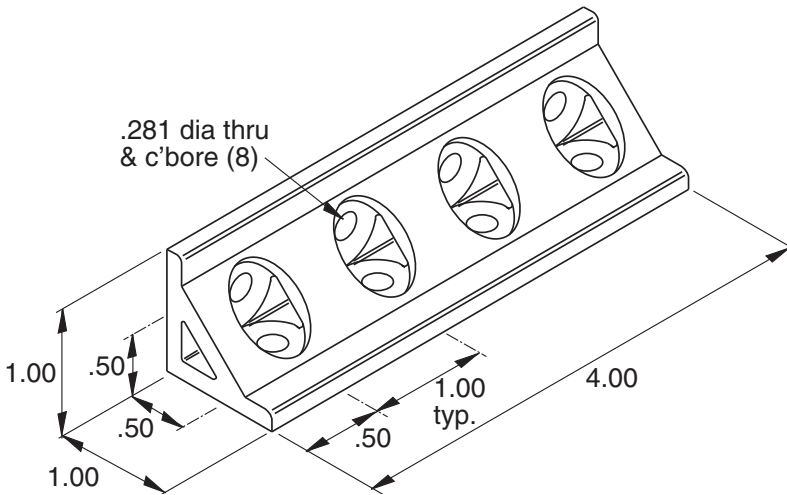

Recommended  
Hardware  
(8) 11-231 BHCS  
(8) 11-210 T-nut

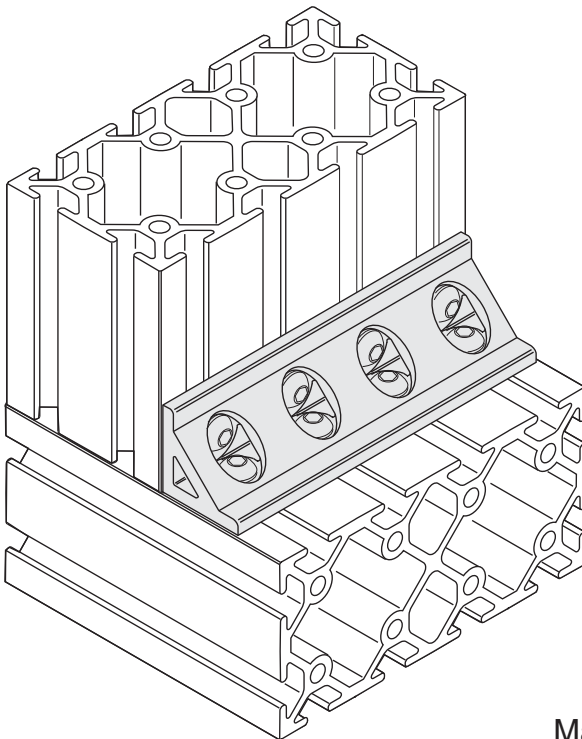

Material - Aluminum  
Finish - Clear Anodize

**1/4" SLOTS**

# Corner Gusset



**11-170**

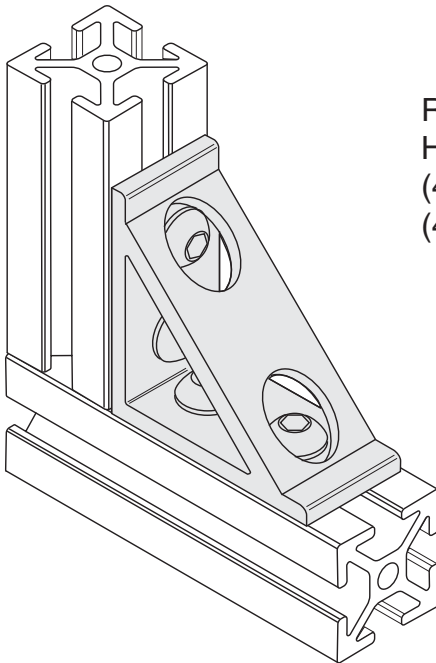
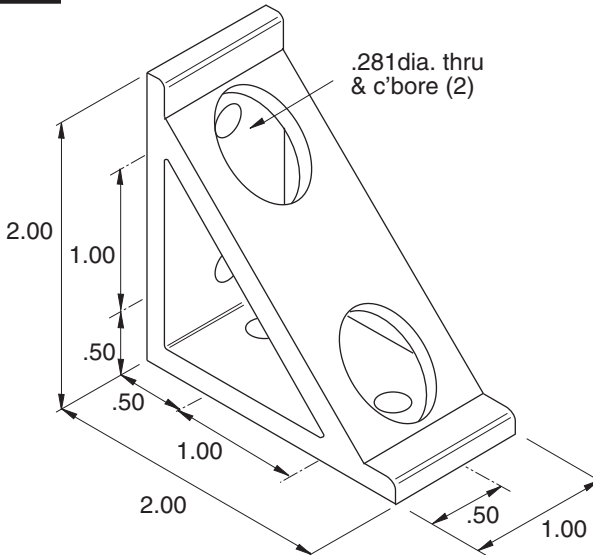

Recommended  
Hardware  
(4) 11-231 BHCS  
(4) 11-210 T-nut

1/4" SLOTS

Material - Aluminum  
Finish - Clear Anodize

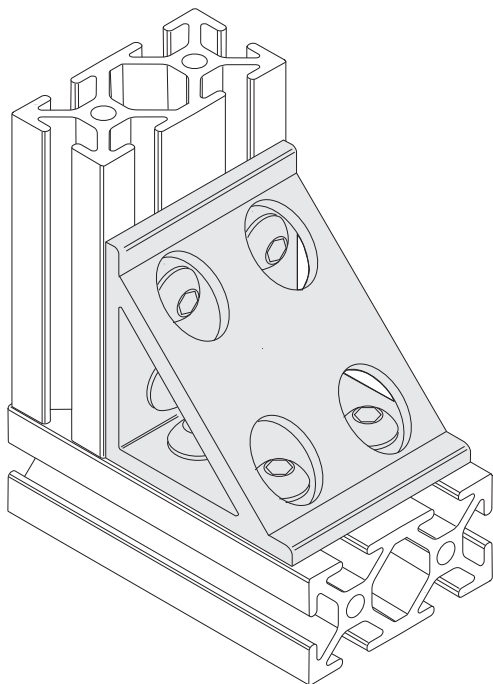
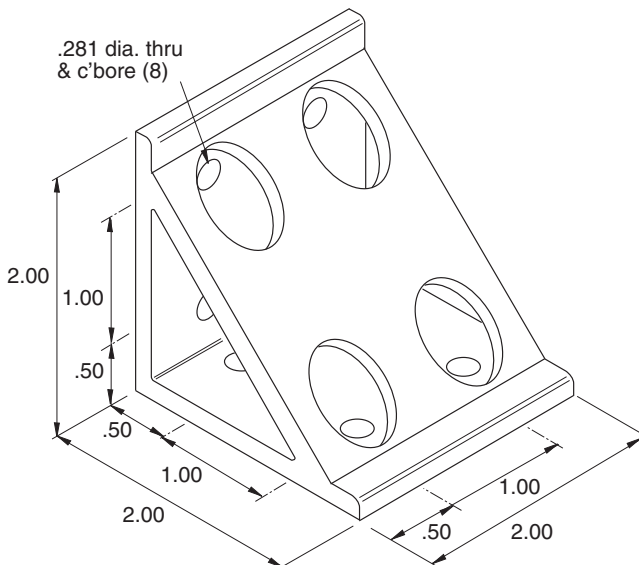

**Recommended  
Hardware**  
(8) 11-231 BHCS  
(8) 11-210 T-nut

**1/4" SLOTS**

**Material - Aluminum  
Finish - Clear Anodize**

# Corner Gusset



**11-172**

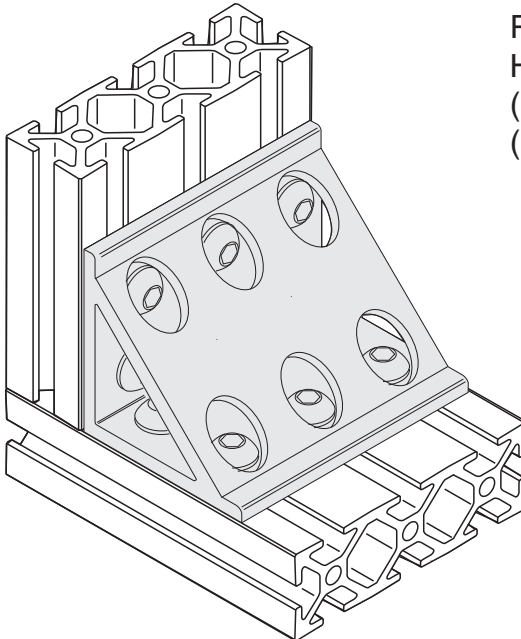
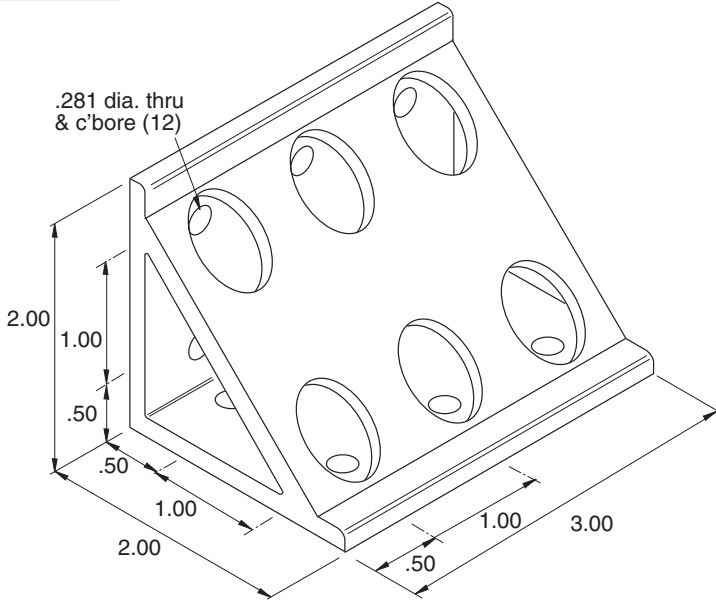

Recommended Hardware  
(12) 11-231 BHCS  
(12) 11-210 T-nut

**1/4" SLOTS**

Material - Aluminum  
Finish - Clear Anodize

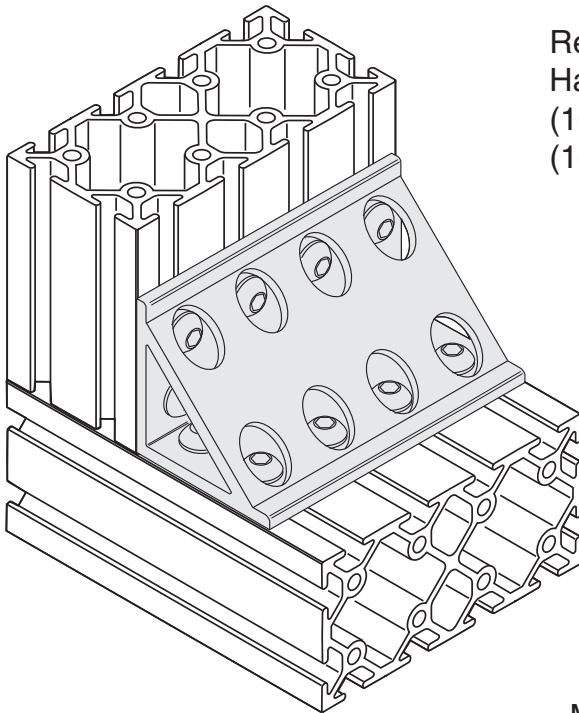
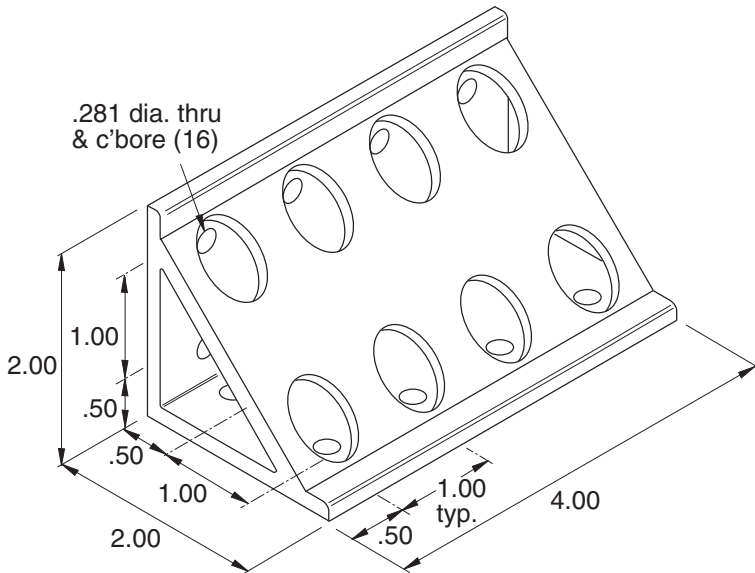

Recommended  
Hardware  
(16) 11-231 BHCS  
(16) 11-210 T-nut

**1/4" SLOTS**

Material - Aluminum  
Finish - Clear Anodize



**11-29**

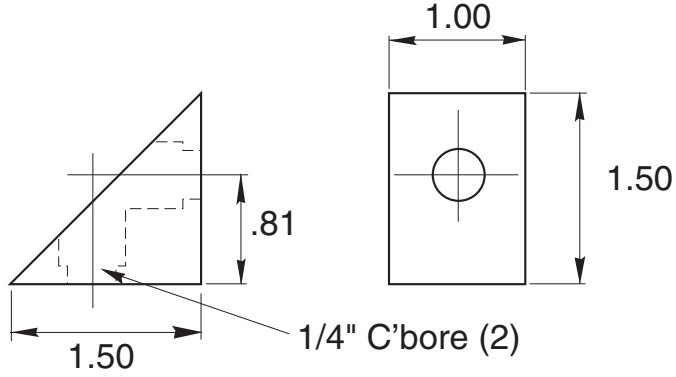

Recommended  
Hardware  
(2) 11-221 SHCS  
(2) 11-210 T-nut

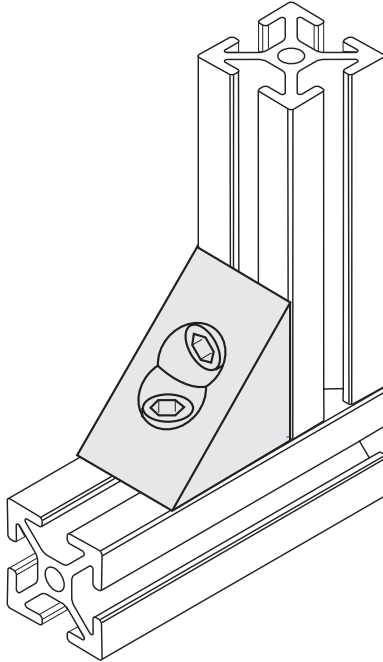

**1/4" SLOTS**

Material - Aluminum  
Finish - Clear Anodize

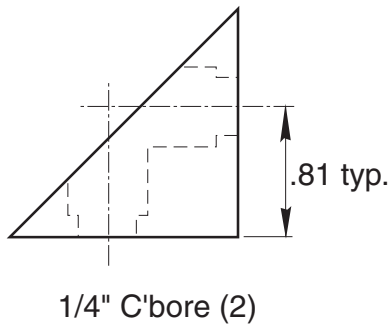
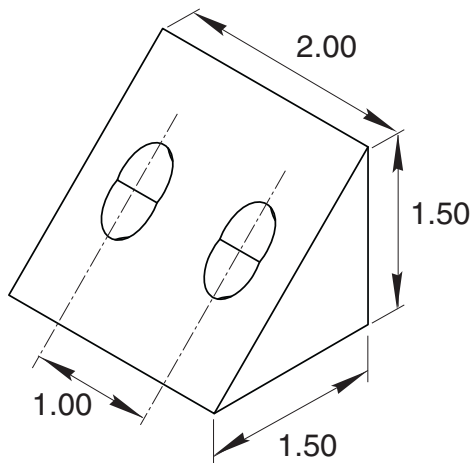

Recommended  
Hardware  
(4) 11-221 SHCS  
(4) 11-210 T-nut

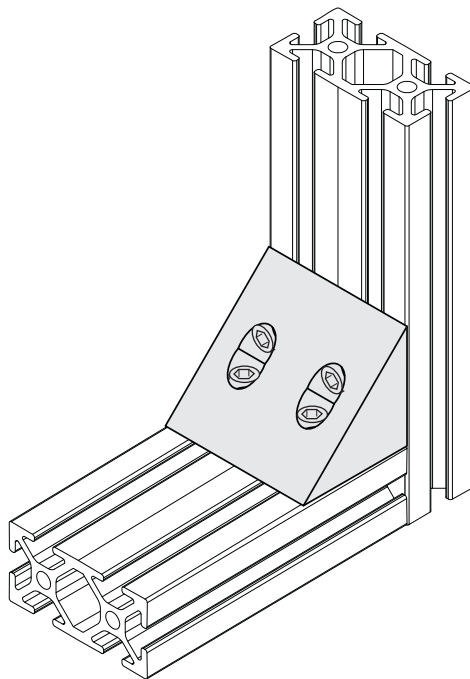

**1/4" SLOTS**

Material - Aluminum  
Finish - Clear Anodize

# Angle Blocks



<b>11-103</b>
<b>11-104</b>

## 11-104

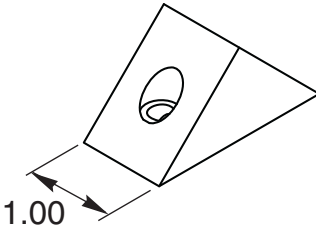
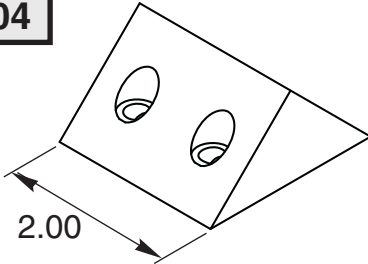

Drilled and c'bore  
for 11-222 SHCS

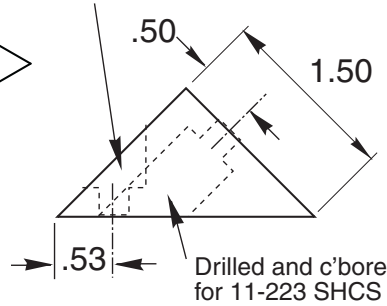

## 11-103

Recommended  
Hardware

### 11-103

- (1) 11-222 SHCS
- (1) 11-223 SHCS
- (1) 11-210 T-nut

### 11-104

- (2) 11-222 SHCS
- (2) 11-223 SHCS
- (2) 11-210 T-nut

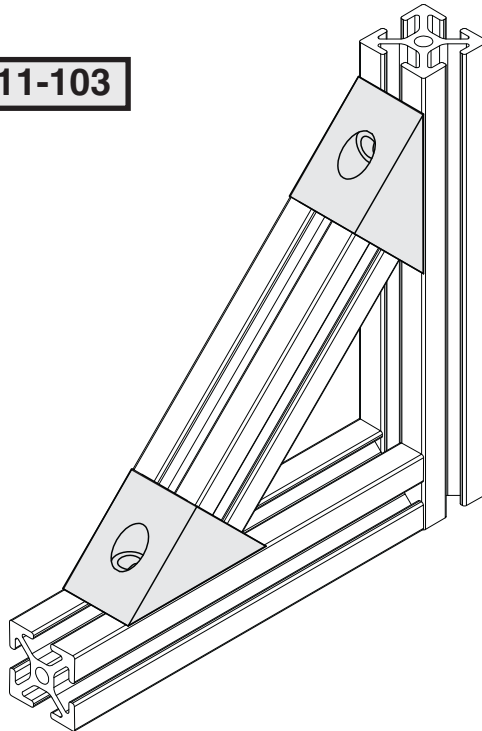

Material - Aluminum  
Finish - Clear Anodize

1/4" SLOTS

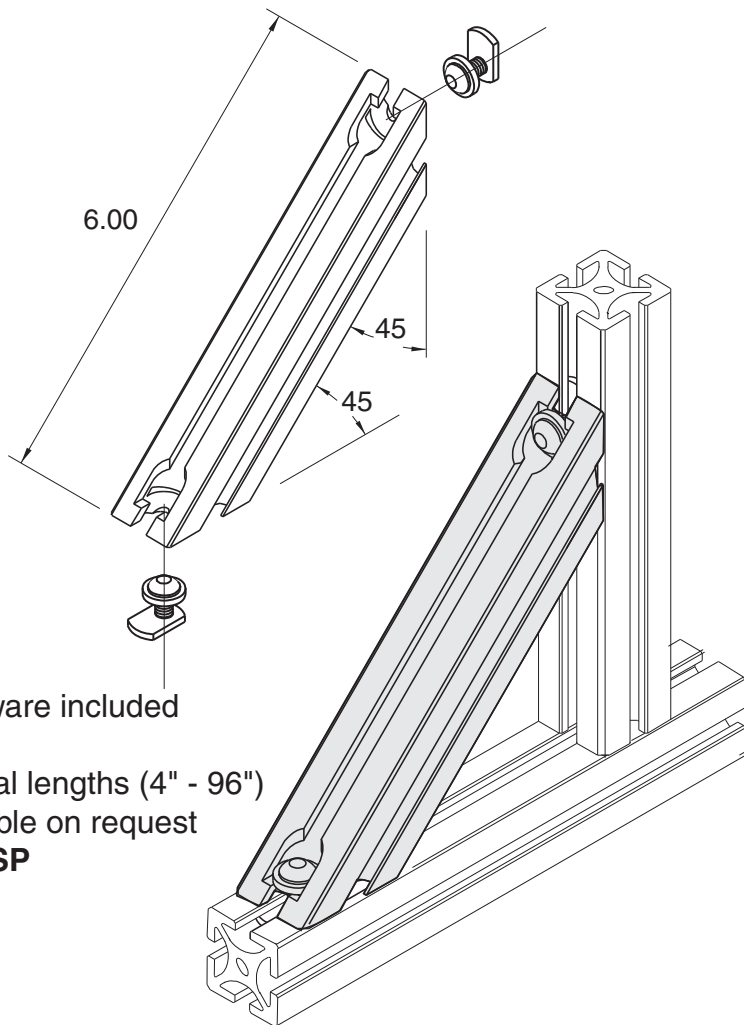

Hardware included

Special lengths (4" - 96")  
available on request  
**11-7-SP**

**1/4" SLOTS**

Material - Aluminum (EX-11)  
Finish - Clear Anodize

**11-12**

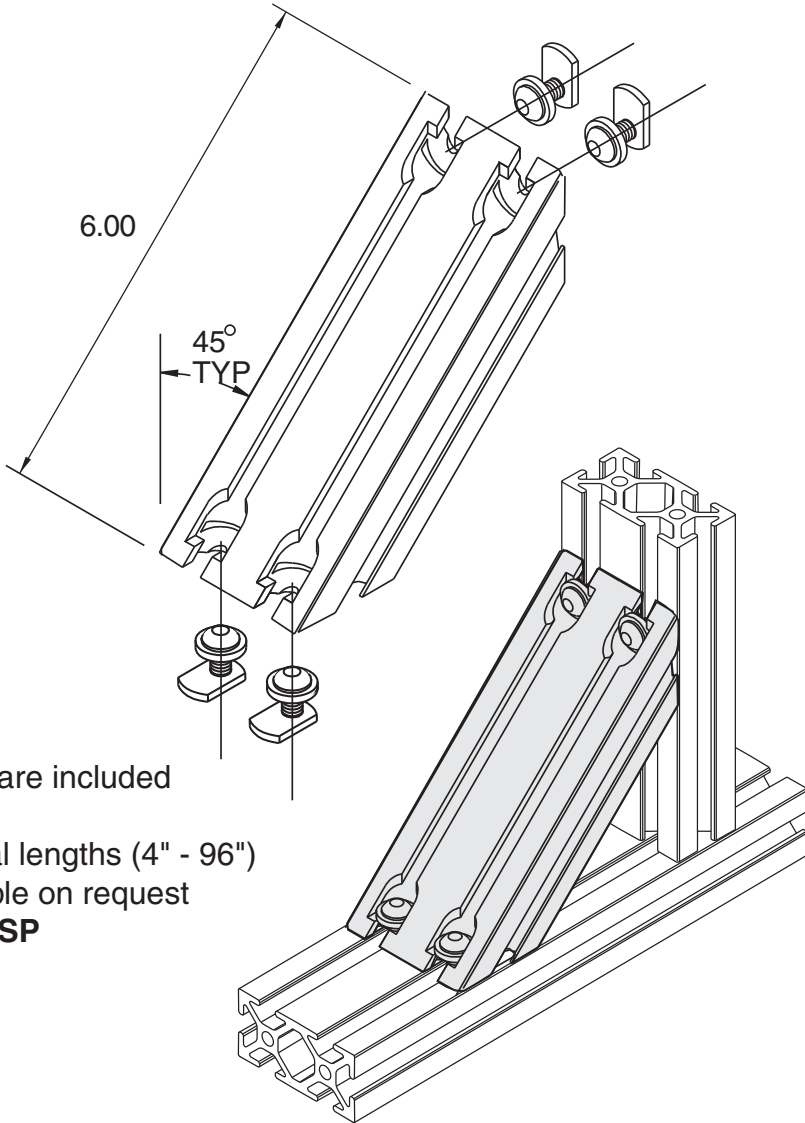

Hardware included

Special lengths (4" - 96")  
available on request  
**11-12-SP**

**1/4" SLOTS**

Material - Aluminum (EX-12)  
Finish - Clear Anodize

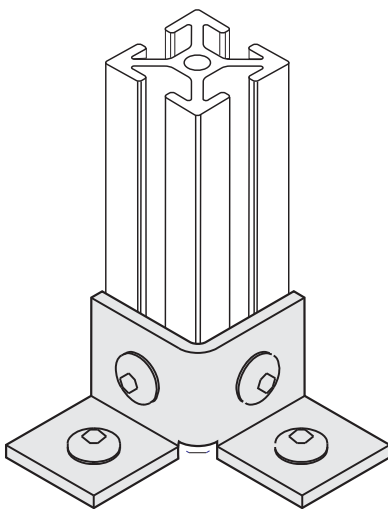
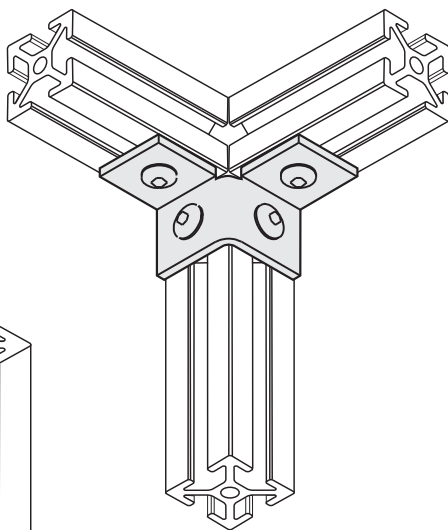
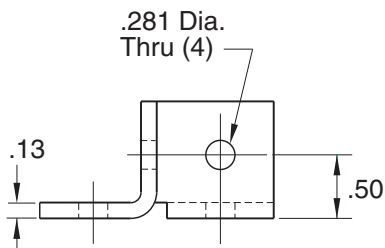
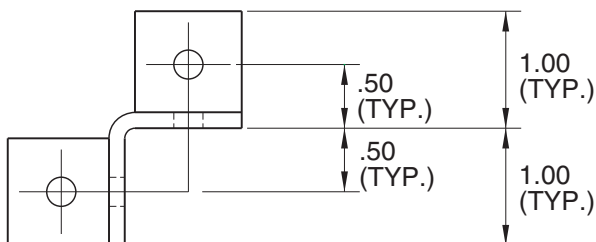

Recommended  
Hardware  
(4) 11-230 BHCS  
(4) 11-210 T-nut

**1/4" SLOTS**

Material - Steel  
Finish - Zinc Plating

**11-60**

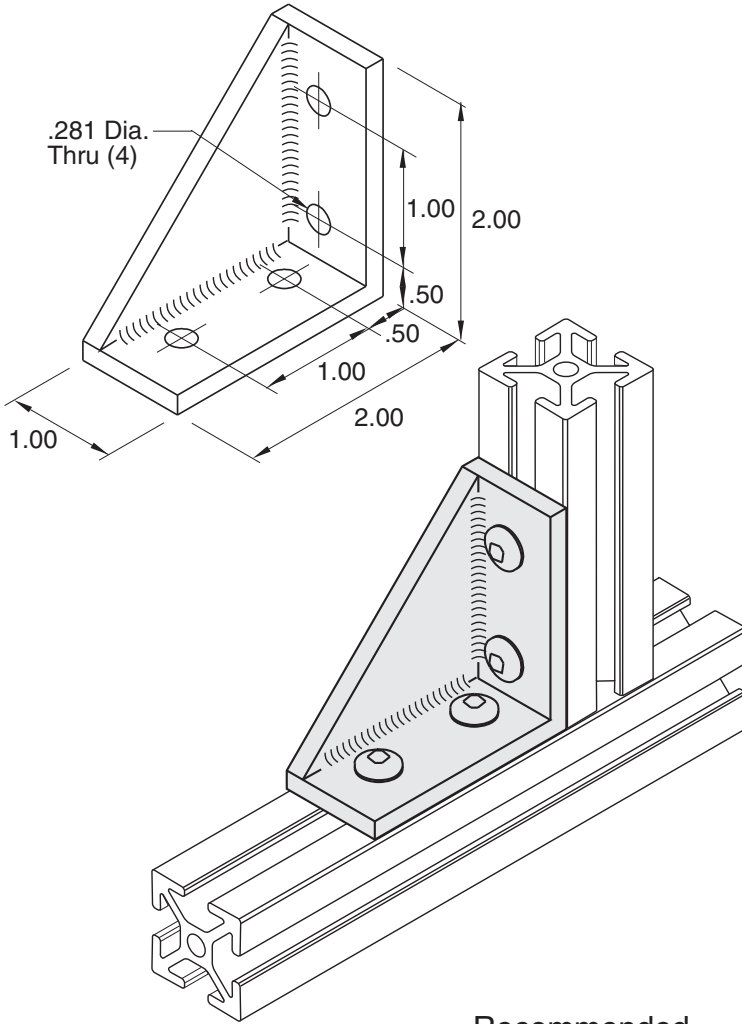

**1/4" SLOTS**

Recommended  
Hardware  
(4) 11-230 BHCS  
(4) 11-210 T-nut

Material - Steel  
Finish - Black Powder Coat

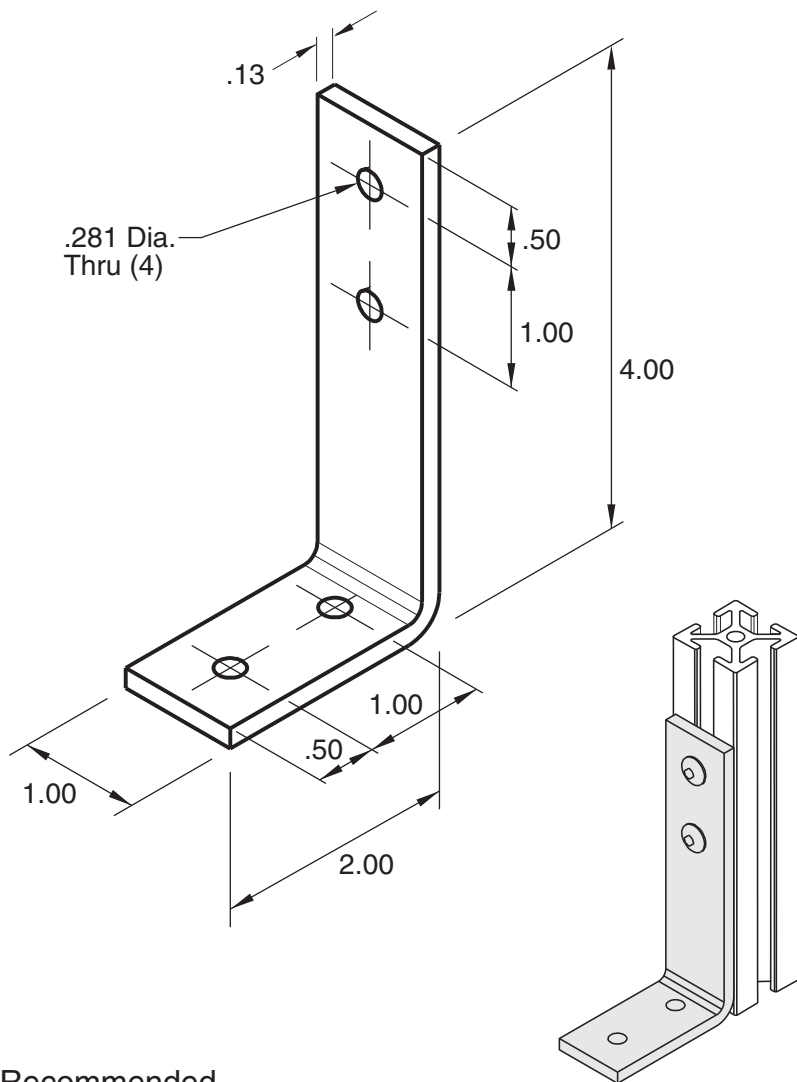

Recommended  
Hardware  
(4) 11-230 BHCS  
(4) 11-210 T-nut

Material - Steel  
Finish - Black Powder Coat

**1/4" SLOTS**



# Welded Steel Angle Bracket



<b>11-61</b>	<b>Left Hand</b>
<b>11-62</b>	<b>Right Hand</b>

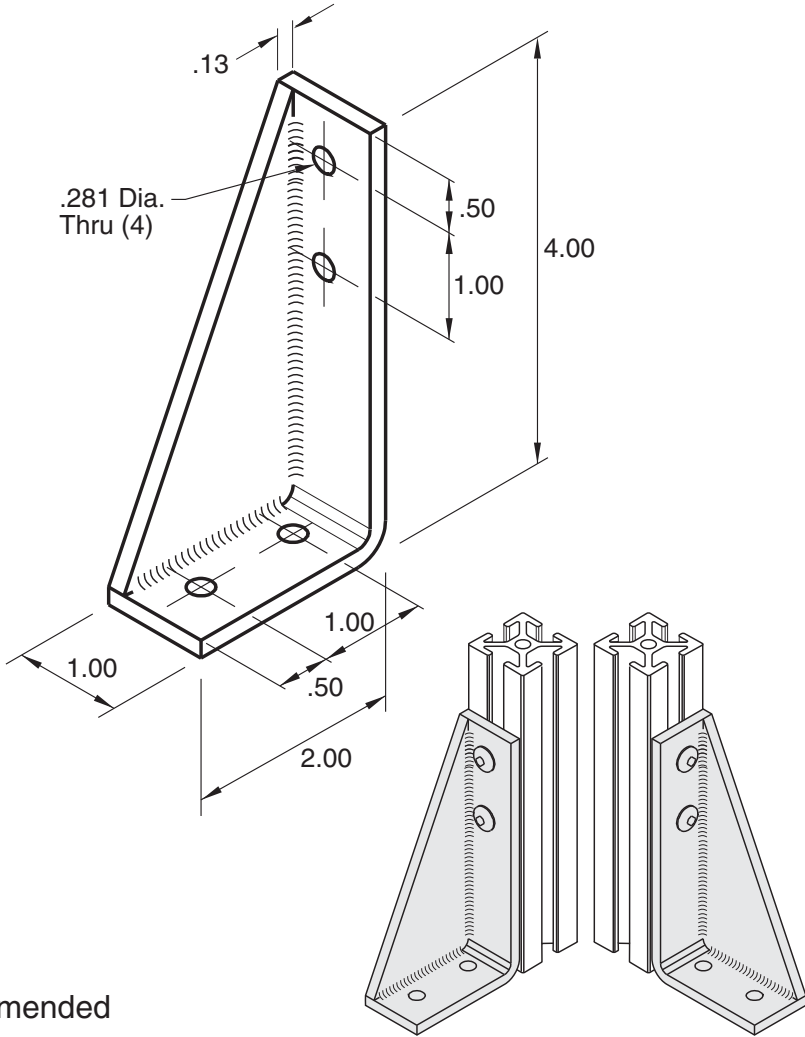

**1/4" SLOTS**

Recommended Hardware  
 (4) 11-230 BHCS  
 (4) 11-210 T-nut

**11-61**  
**Left Hand**

**11-62**  
**Right Hand**

Material - Steel  
 Finish - Black Powder Coat

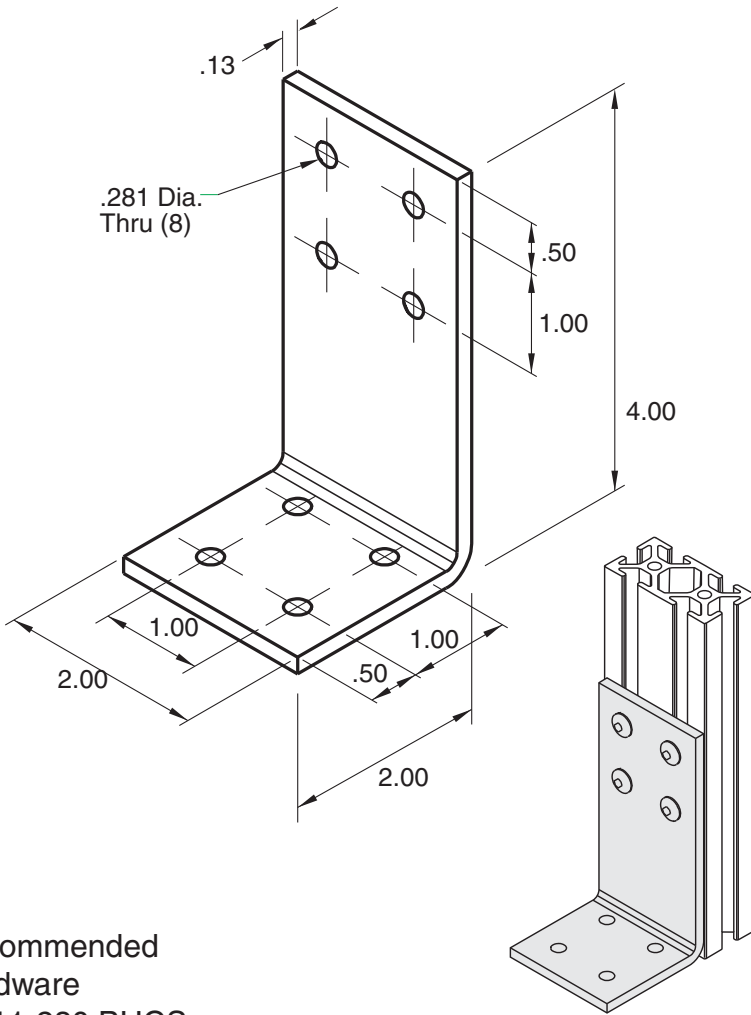

Recommended  
Hardware  
(8) 11-230 BHCS  
(8) 11-210 T-nut

Material - Steel  
Finish - Black Powder Coat

**1/4" SLOTS**

11-63

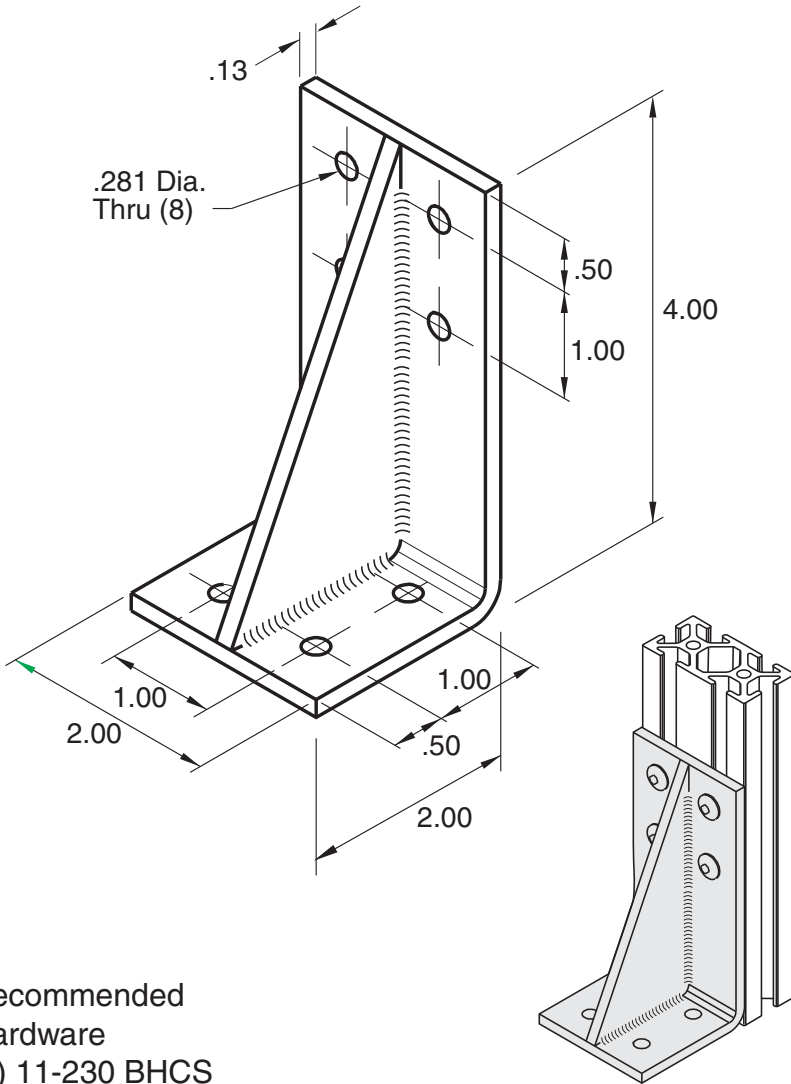

1/4" SLOTS

Recommended Hardware  
(8) 11-230 BHCS  
(8) 11-210 T-nut

Material - Steel  
Finish - Black Powder Coat

with Hardware	<b>11-242</b>
without Hardware	<b>11-242P</b>
with Metric Hardware	<b>11-242M</b>

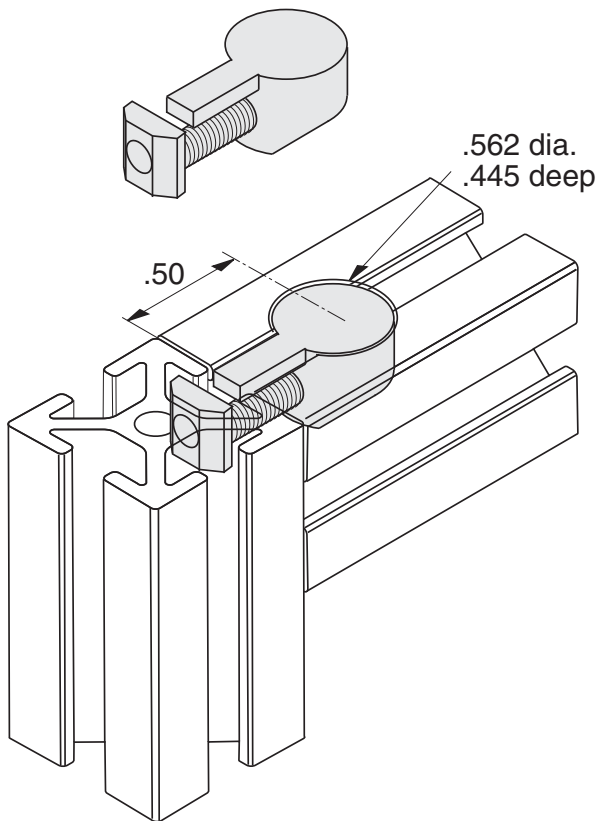

**1/4" SLOTS**

**Material:**  
 Anchor - Cast Zinc, Zinc Plated  
 Bolt - Steel, Black Oxide Coating  
 T-nut - Steel Zinc Coated

# Double Anchor Fastener



<b>11-248</b>
<b>11-248M</b>
<b>11-249</b>
<b>11-249M</b>

**with Metric Hardware**

**with Metric Hardware**

**11-248** x=1.0

**11-249** x=2.0

Hardware Included

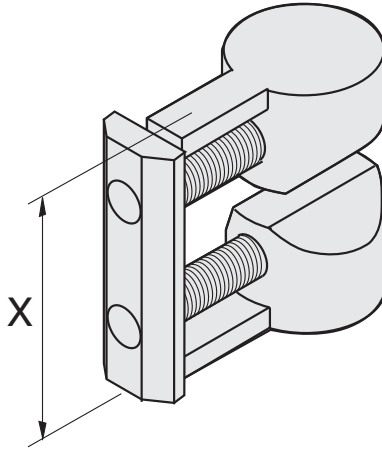

.562 dia. x .445 deep (2) plces

.500

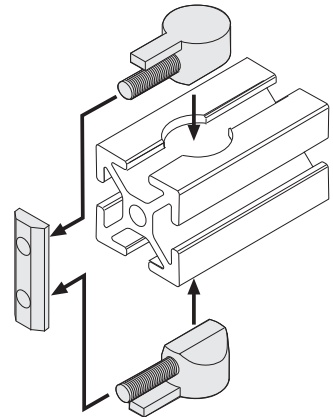
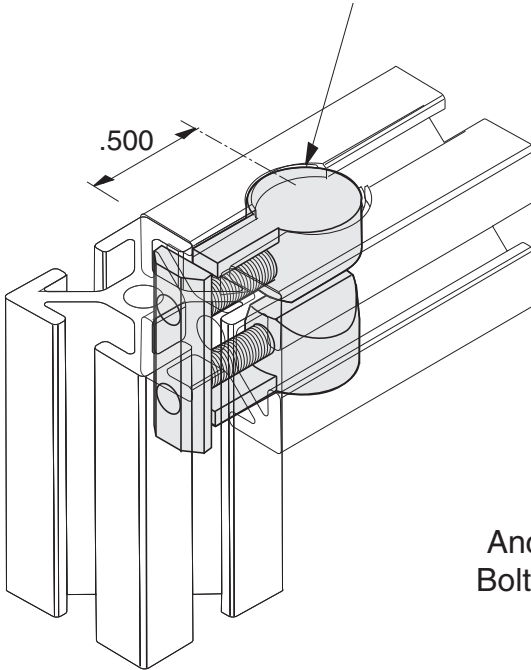

**Material:**

- Anchor - Cast Zinc, Zinc Plated**
- Bolt - Steel, Black Oxide Coating**
- T-nut - Steel Zinc Coated**

**1/4" SLOTS**

**11-243**

**with metric Hardware**

**11-234M**

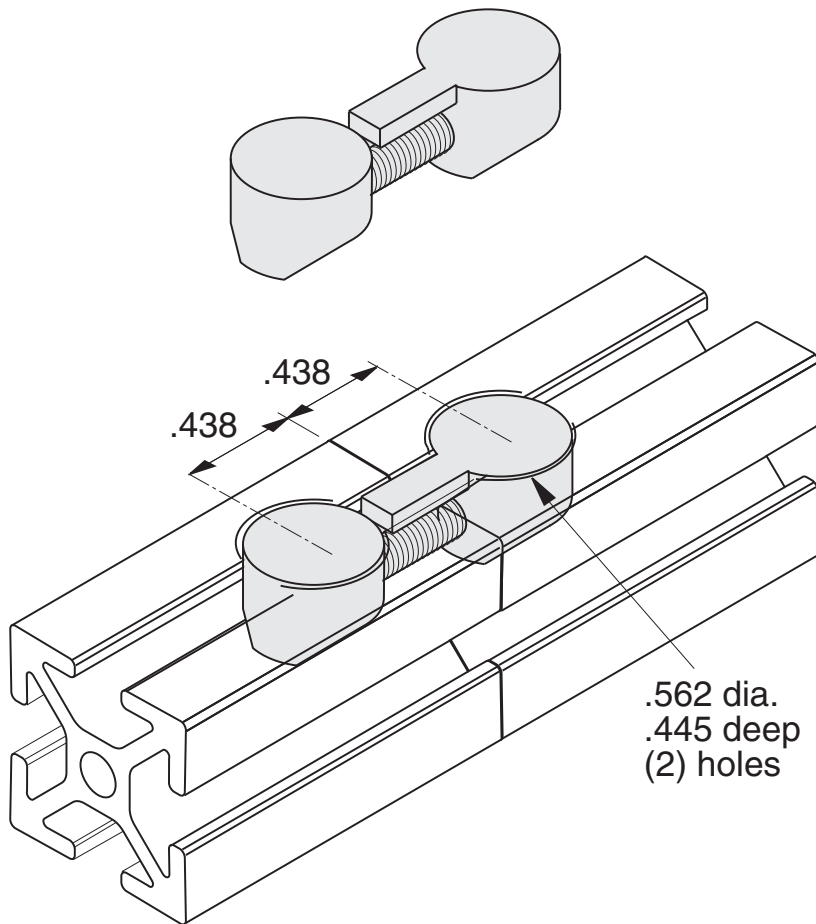

Hardware Included

Material:  
Anchor - Cast Zinc, Zinc Plated  
Bolt - Steel, Black Oxide Coating  
T-nut - Steel Zinc Coated

**1/4" SLOTS**

# Universal Connector



<b>11-262</b>	<b>Zinc Plated Steel</b>
<b>11-262SS</b>	<b>Stainless Steel</b>

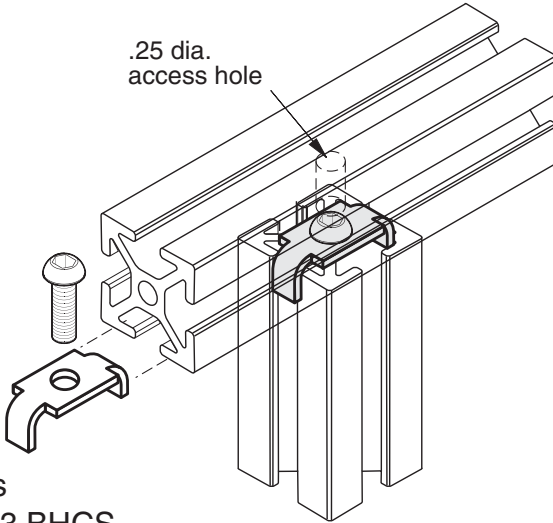

Requires  
(1)11-233 BHCS

# Universal Panel Connector

<b>11-267</b>	<b>Zinc Plated Steel</b>
<b>11-267SS</b>	<b>Stainless Steel</b>

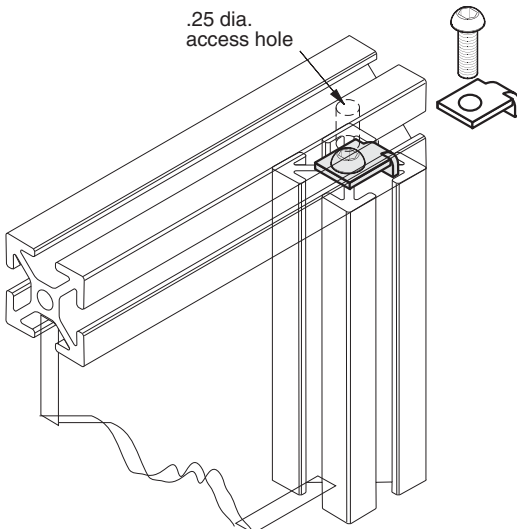

Requires  
(1)11-233 BHCS

No panel  
trimming  
required

1/4" SLOTS

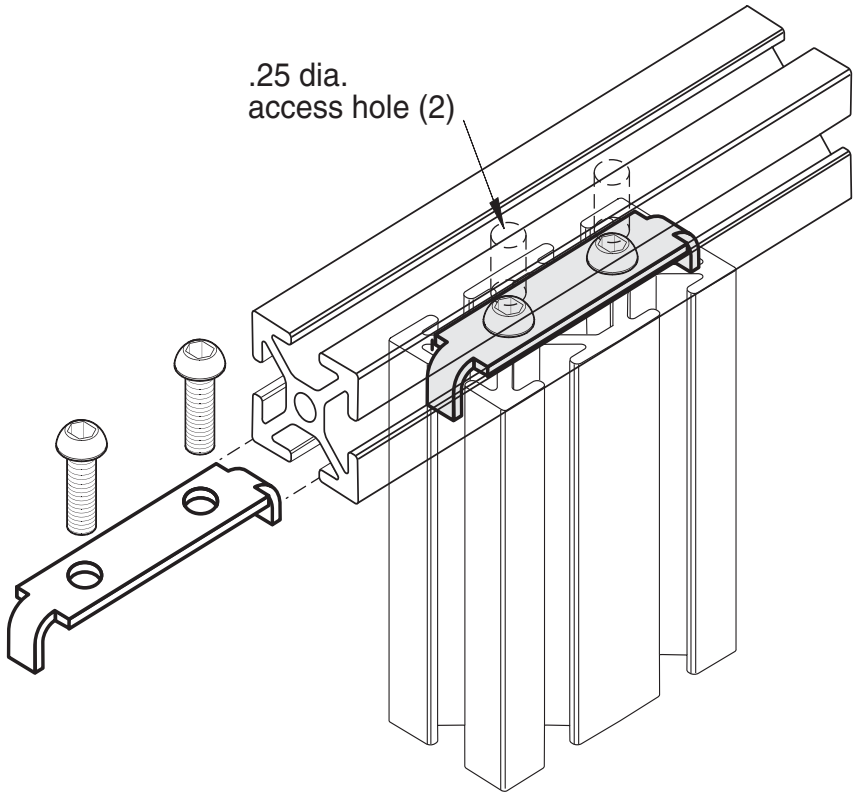

Recommended  
Hardware  
(2) 11-233 BHCS

Material - Steel  
Finish - Zinc Plated

**1/4" SLOTS**



**11-269**

use with EX-70, EX-71, EX-72 and EX-73

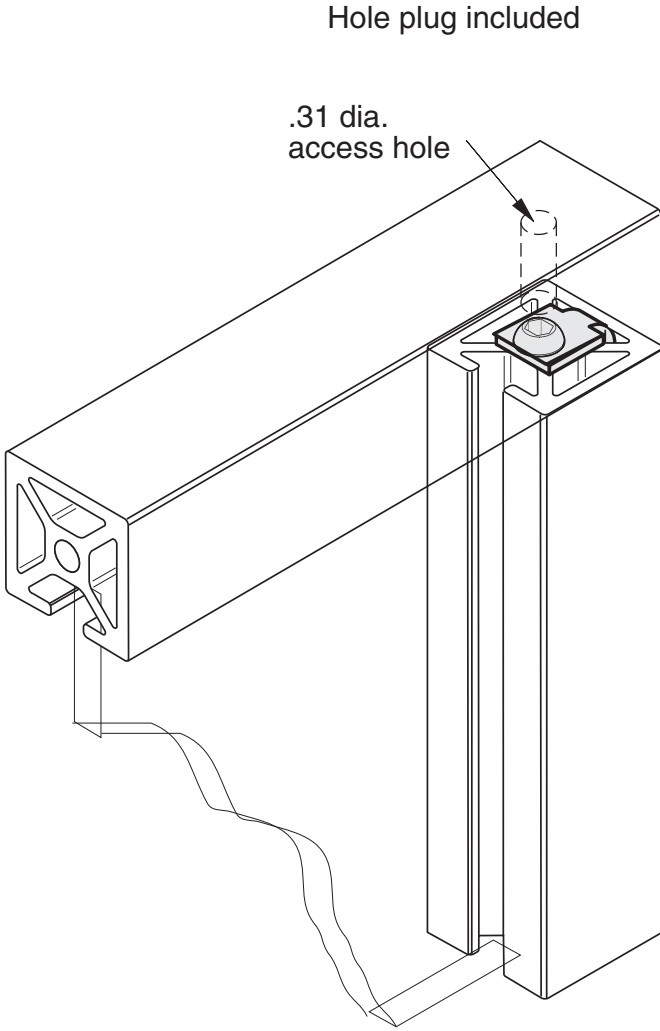

Hole plug included

.31 dia.  
access hole

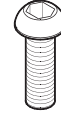

No panel trimming  
required.

**1/4" SLOTS**

Recommended  
Hardware  
(1) 11-233 BHCS

Material - Steel  
Finish - Zinc Plated

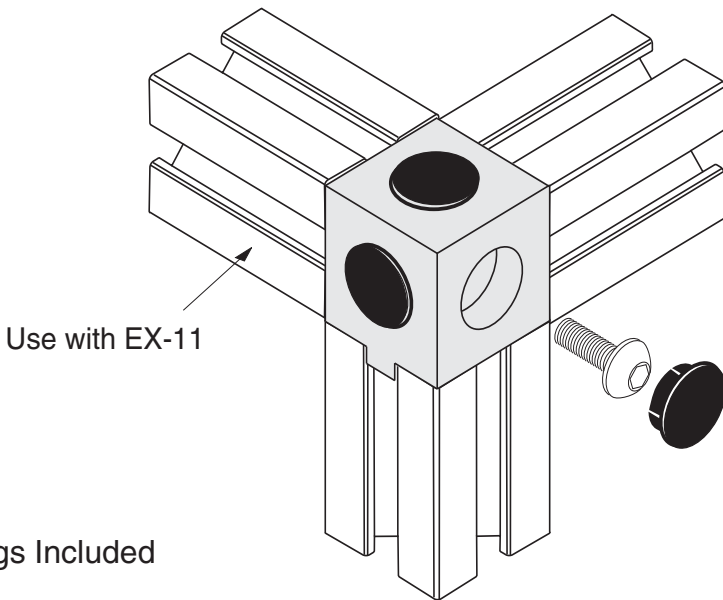
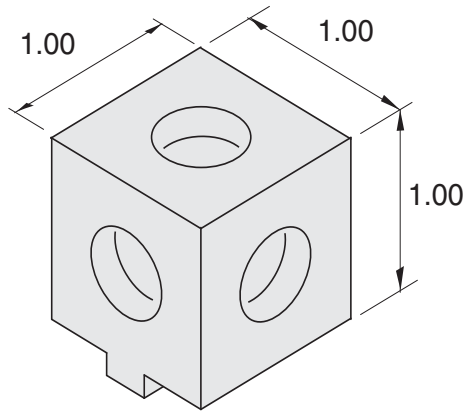

**1/4" SLOTS**

Hole Plugs Included

Recommended  
Hardware  
(3) 11-233 BHCS

Material - Aluminum  
Finish - Clear Anodize

**11-56**

For 1" x 1" 1/4" Slot Profiles

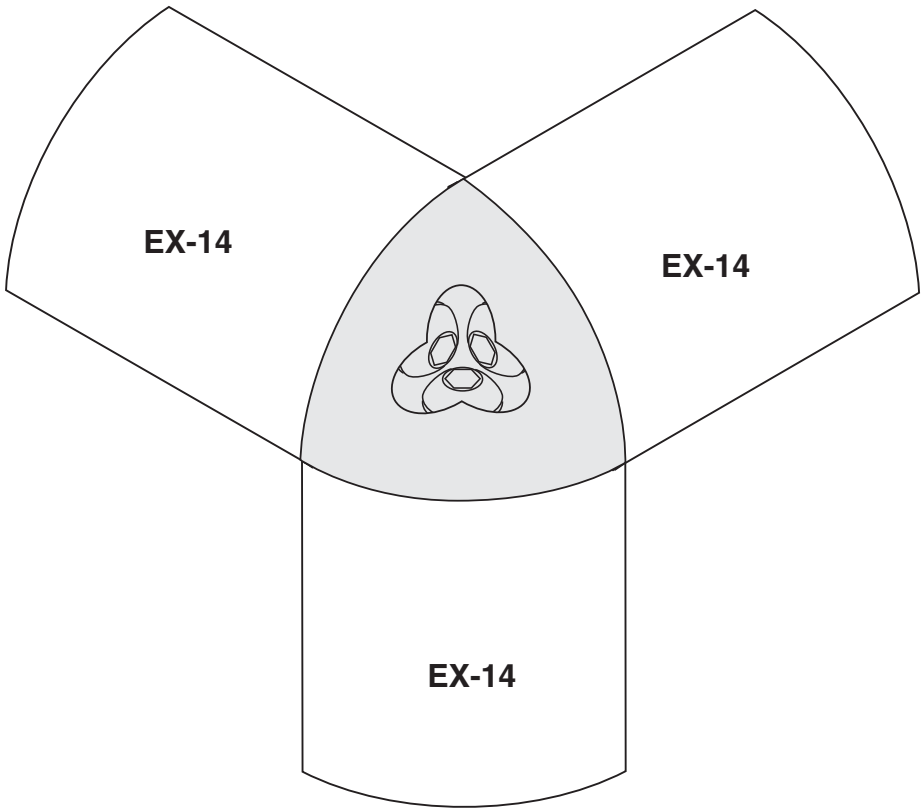

**1/4" SLOTS**

Hardware Included  
Material - Aluminum  
Finish - Clear Anodize

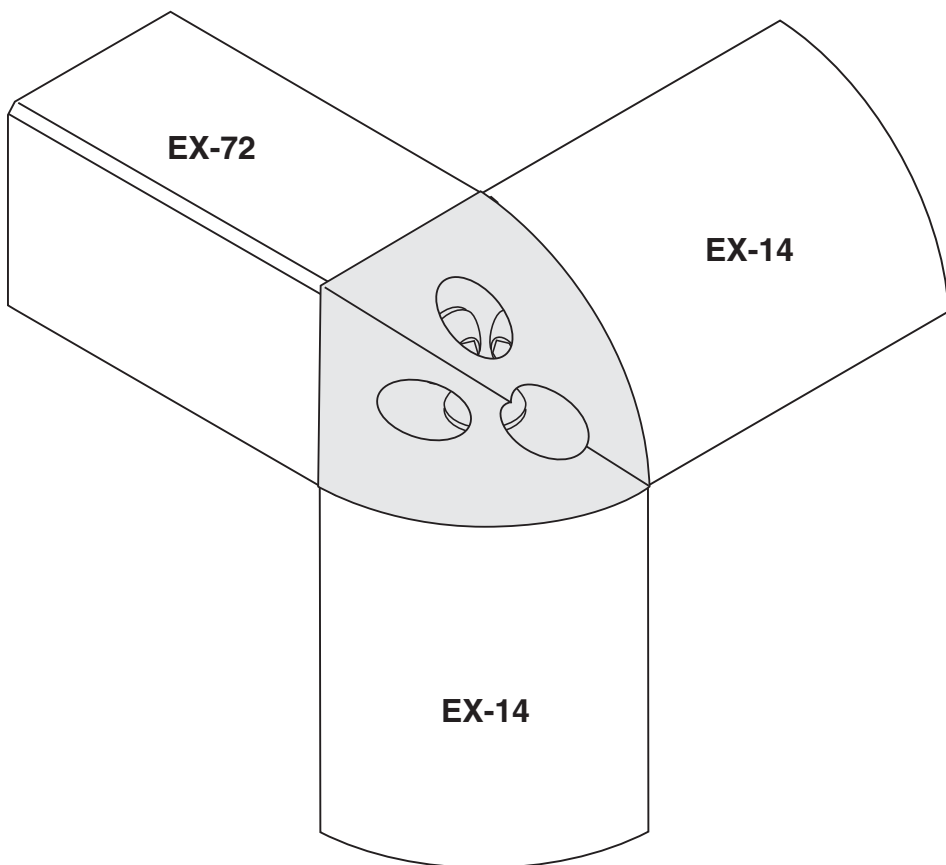

**1/4" SLOTS**

Hardware Included  
Material - Aluminum  
Finish - Clear Anodize

**11-58**

For 1" x 1" 1/4" Slot Profiles

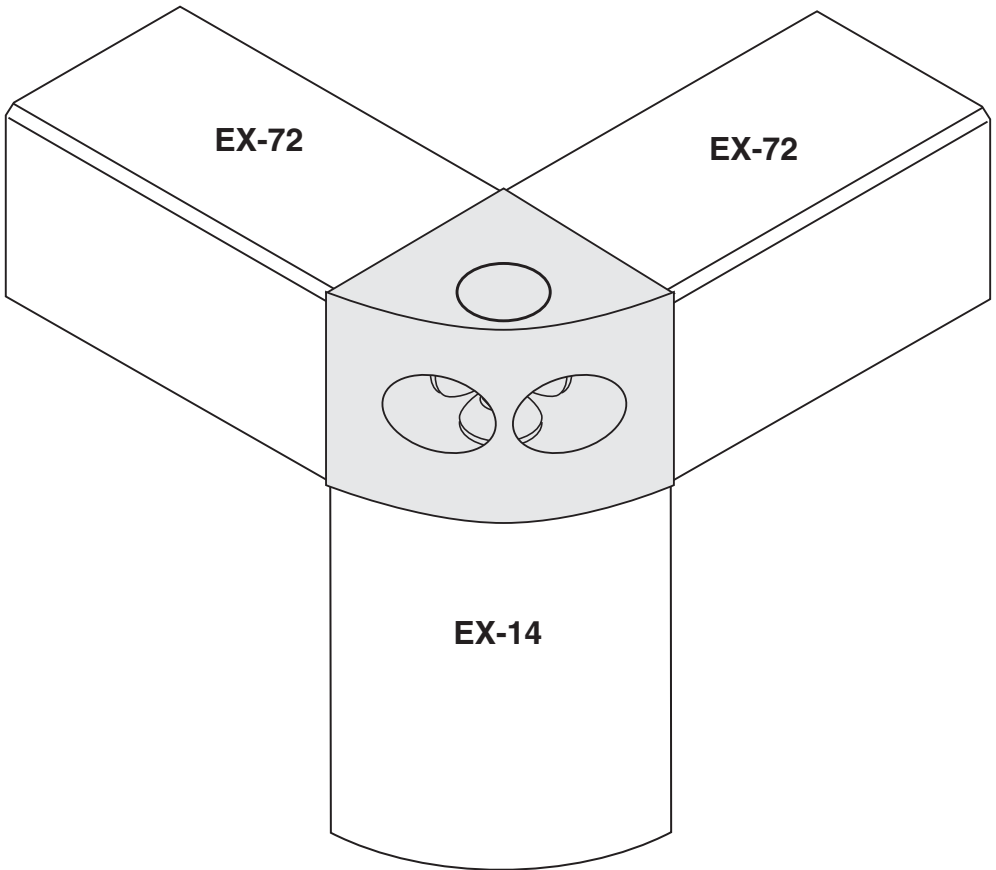

**1/4" SLOTS**

Hardware Included  
Material - Aluminum  
Finish - Clear Anodize

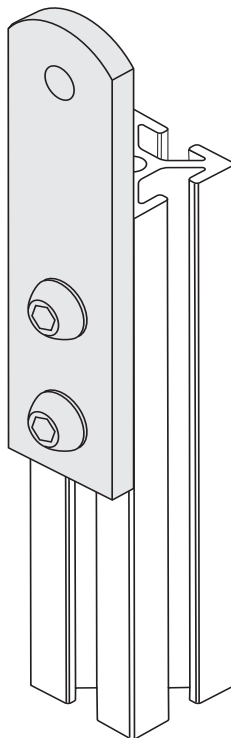
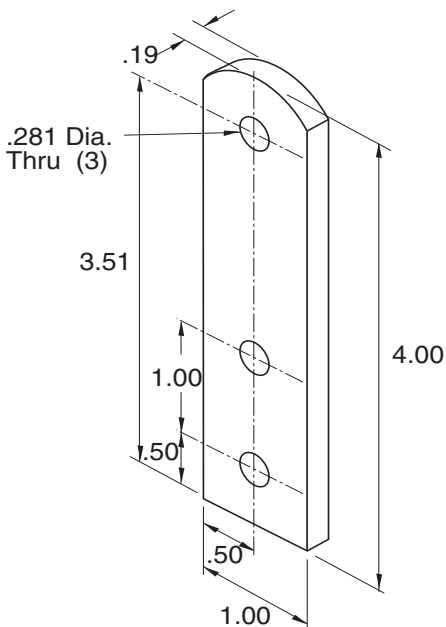

Assembled

(1) 11-10

(2) 11-11

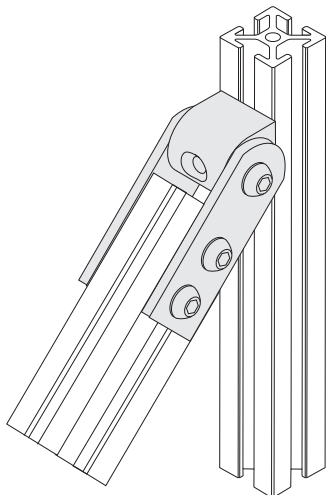

Recommended  
Hardware

(3) 11-231 BHCS

(2) 11-210 T-nut

**1/4" SLOTS**

Material - Aluminum  
Finish - Clear Anodize

**11-10**

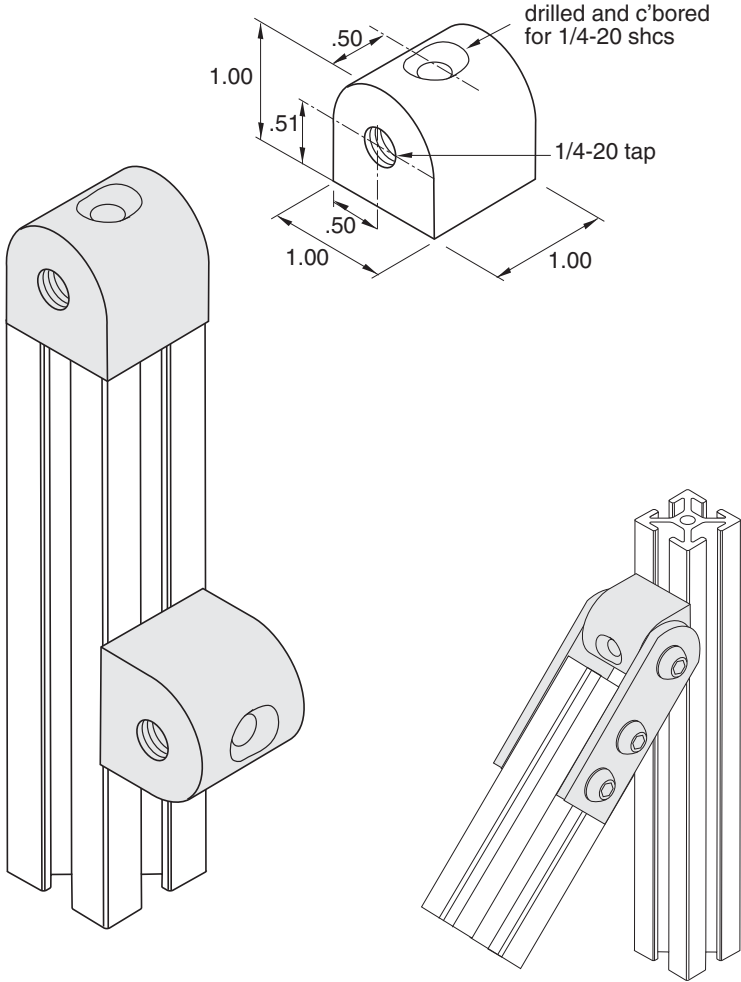

**1/4" SLOTS**

Recommended Hardware  
(1) 11-224 SHCS  
(1) 11-210 T-nut

Assembled  
(1) 11-10  
(2) 11-11

Material - Aluminum  
Finish - Clear Anodize

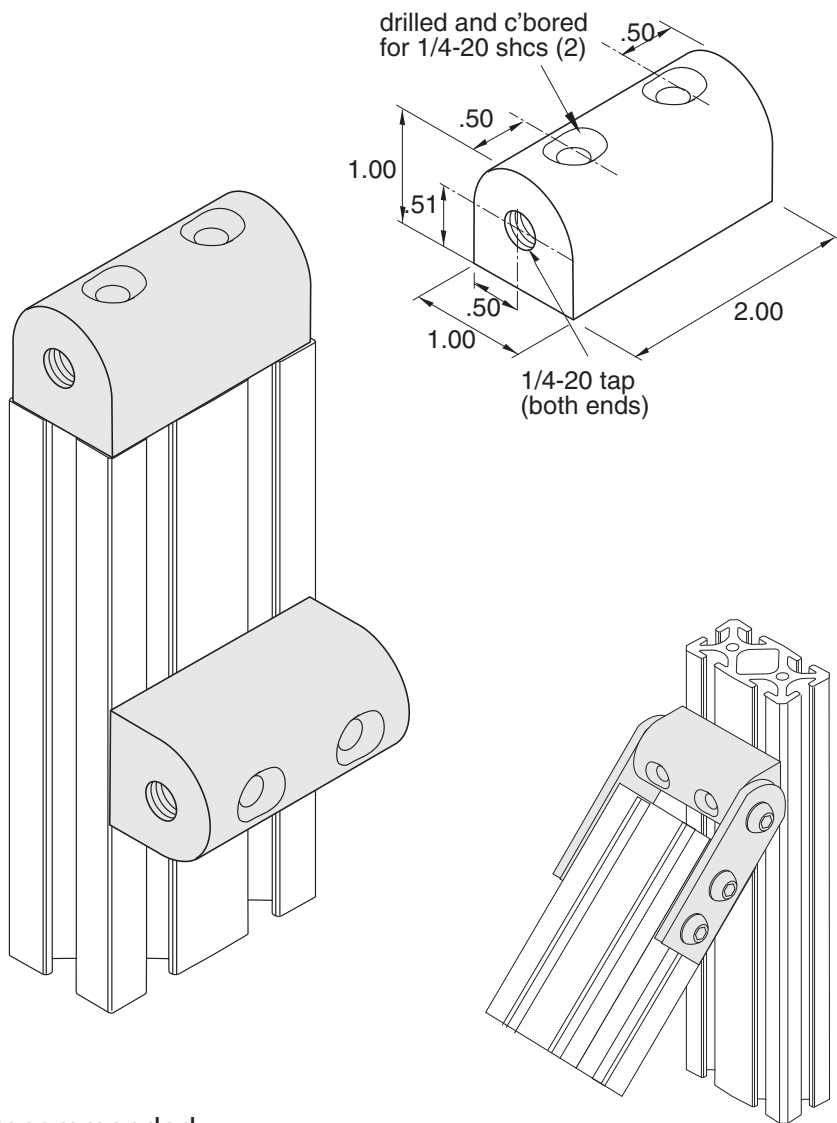

**Recommended  
Hardware**  
(2) 11-224 SHCS  
(2) 11-210 T-nut

**Assembled**  
(1) 11-9  
(2) 11-11

**Material - Aluminum  
Finish - Clear Anodize**

**1/4" SLOTS**



# Pivoting Post Arm with Bushing



**11-105** use with 11-108 or 11-109

For shoulder bolt,  
order (1) 11-204

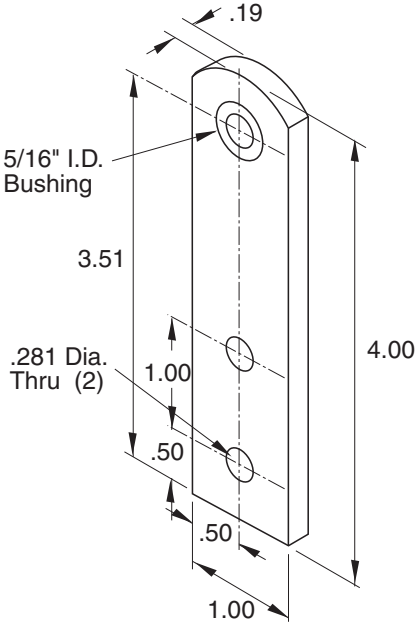

Recommended  
Hardware  
(2) 11-210 T-nut  
(2) 11-231 BHCS  
(1) 11-204 Sholder Bolt

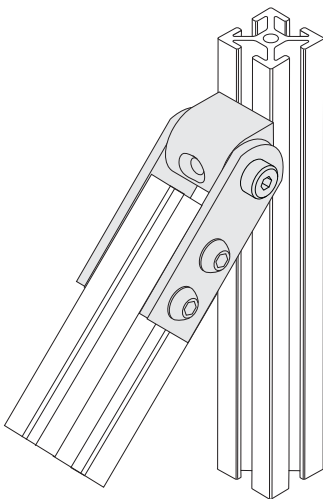
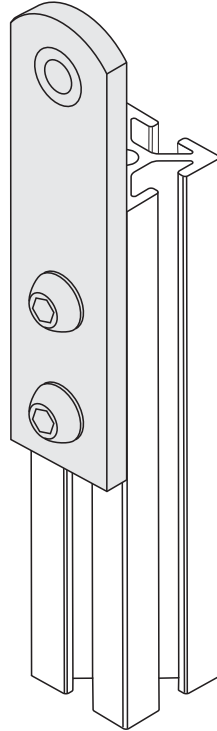

Assembled  
(2) 11-105  
(1) 11-109  
(2) 11-204

Material - Aluminum  
Finish - Clear Anodize

1/4" SLOTS

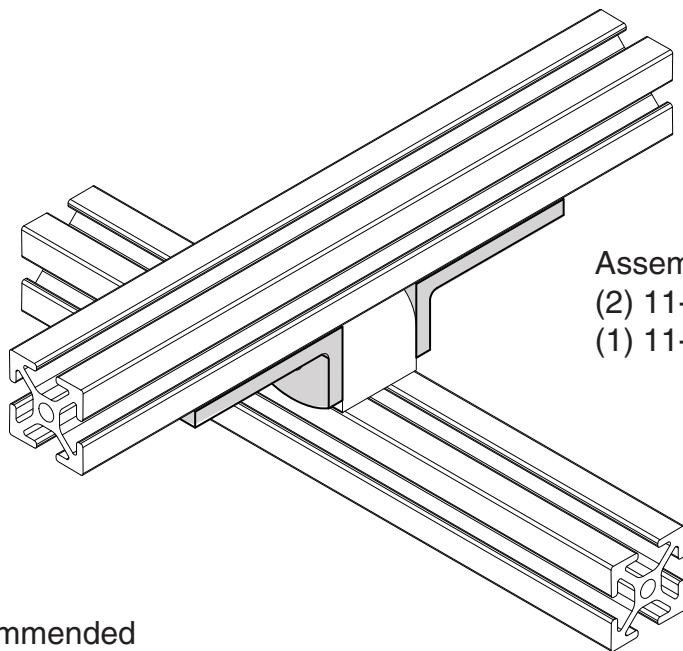
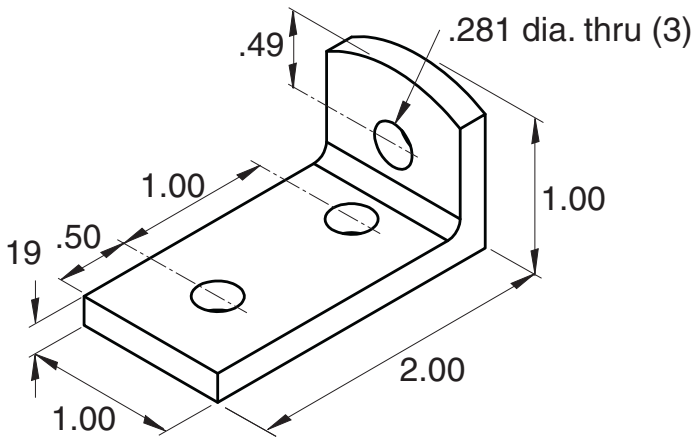

Assembled  
(2) 11-106  
(1) 11-10

Recommended  
Hardware  
(3) 11-231 BHCS  
(2) 11-210 T-nut

Material - Aluminum  
Finish - Clear Anodize

**1/4" SLOTS**

**11-107** use with 11-108 or 11-109

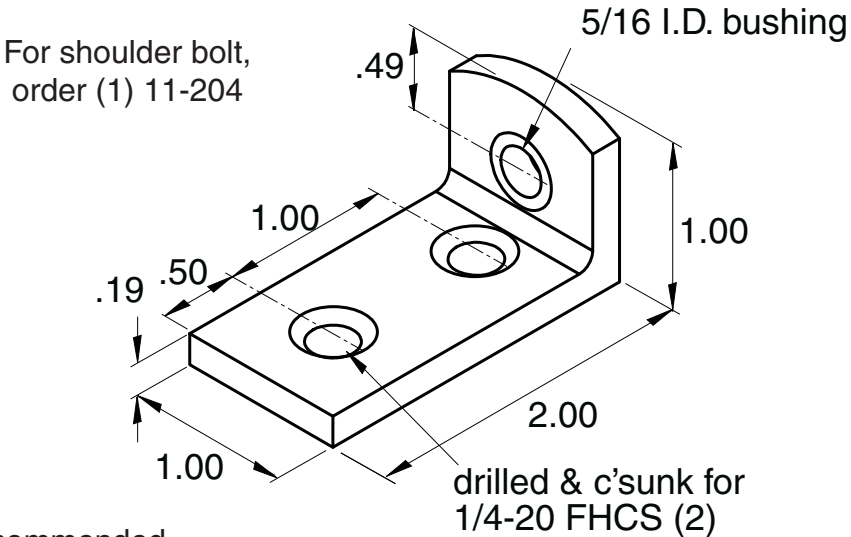

- Recommended Hardware
- (2) 1/4-20 x .5 FHSC
  - (2) 11-210 T-nut
  - (1) 11-204 Shoulder Bolt

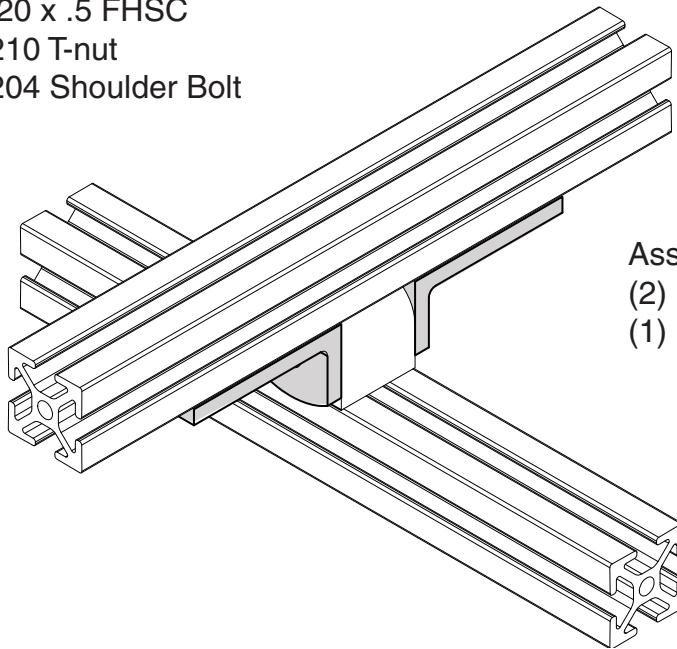

Assembled  
(2) 11-107  
(1) 11-109

1/4" SLOTS

Material - Aluminum  
Finish - Clear Anodize

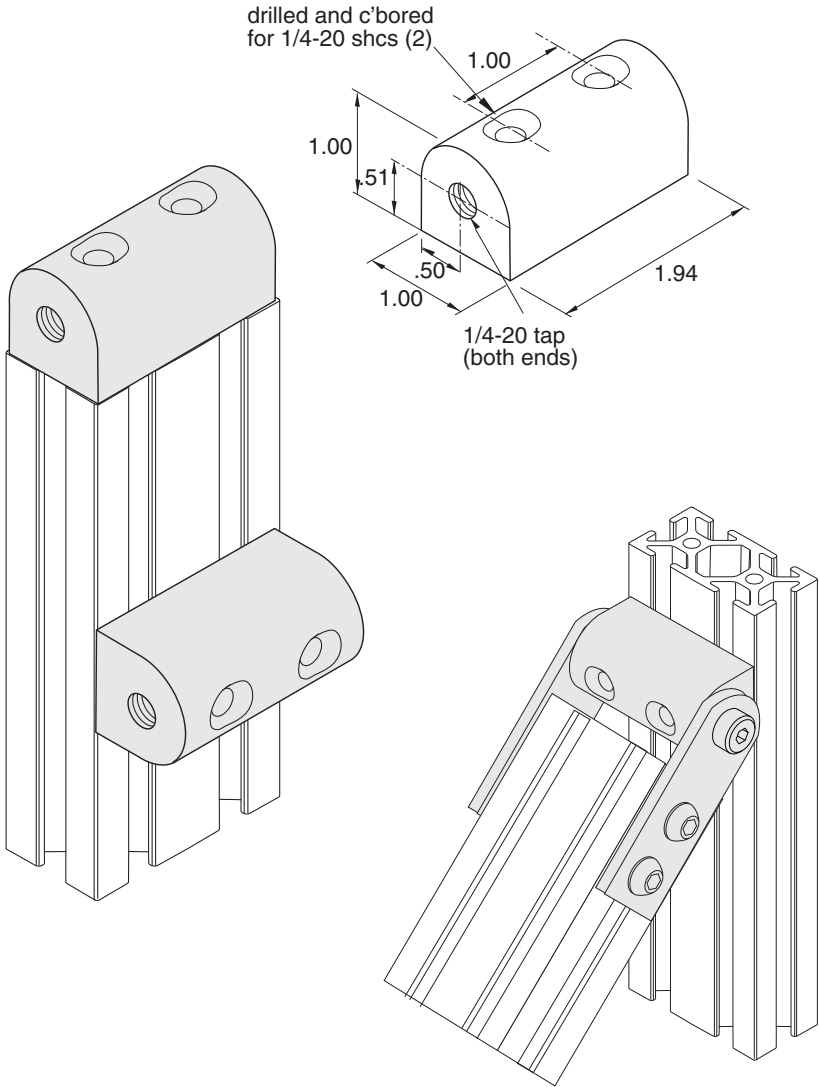

Recommended  
Hardware  
(2) 11-224 BHCS  
(2) 11-210 T-nut

Assembled  
(2) 11-105  
(1) 11-108  
(2) 11-204

Material - Aluminum  
Finish - Clear Anodize

**1/4" SLOTS**

# Pivoting Corner Post



**11-109** use with 11-105 or 11-107

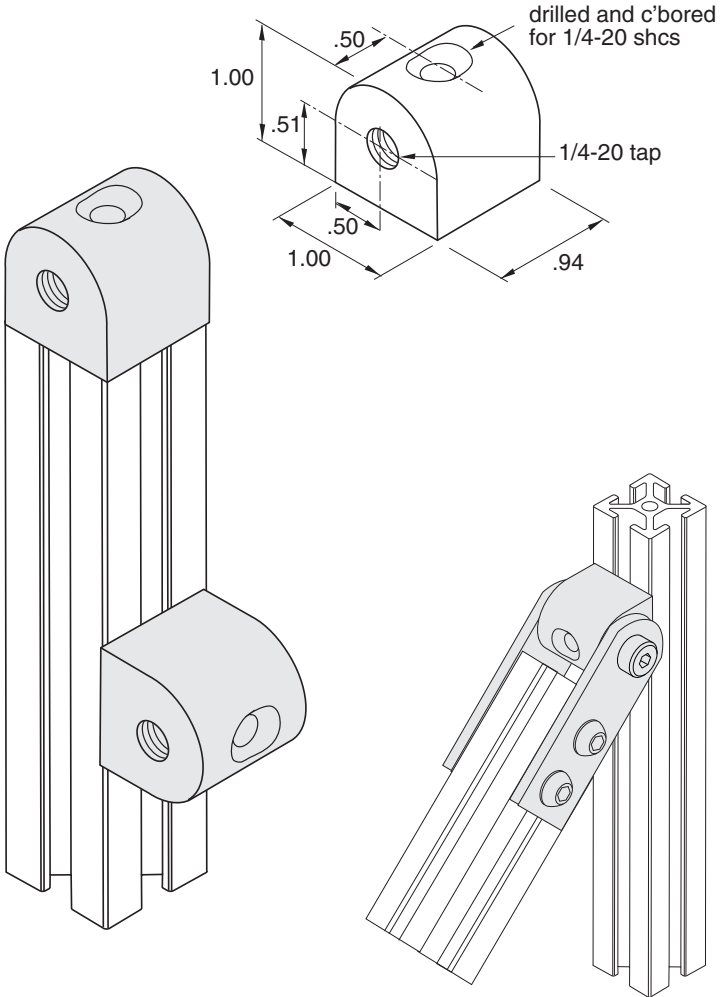

1/4" SLOTS

Recommended Hardware  
(1) 11-224 BHCS  
(1) 11-210 T-nut

Assembled  
(2) 11-105  
(1) 11-109  
(2) 11-204

Material - Aluminum  
Finish - Clear Anodize

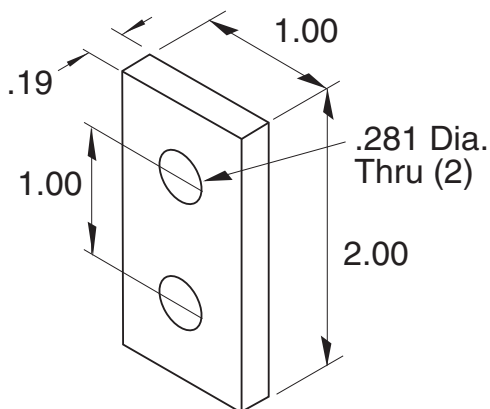

Recommended  
Hardware  
(2) 11-231 BHCS  
(2) 11-210 T-nut

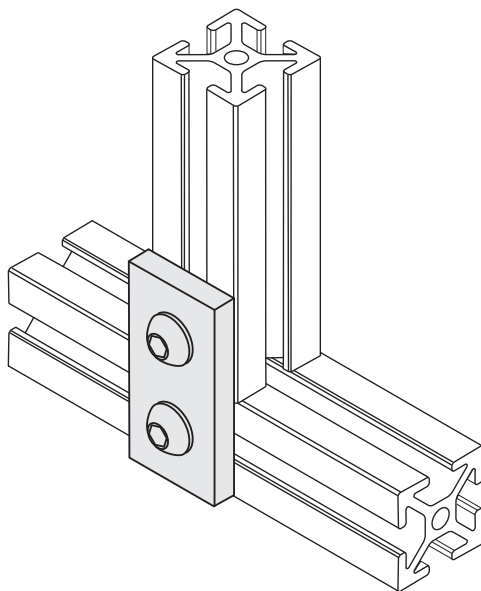

**1/4" SLOTS**

Material - Aluminum  
Finish - Clear Anodize

**11-23**

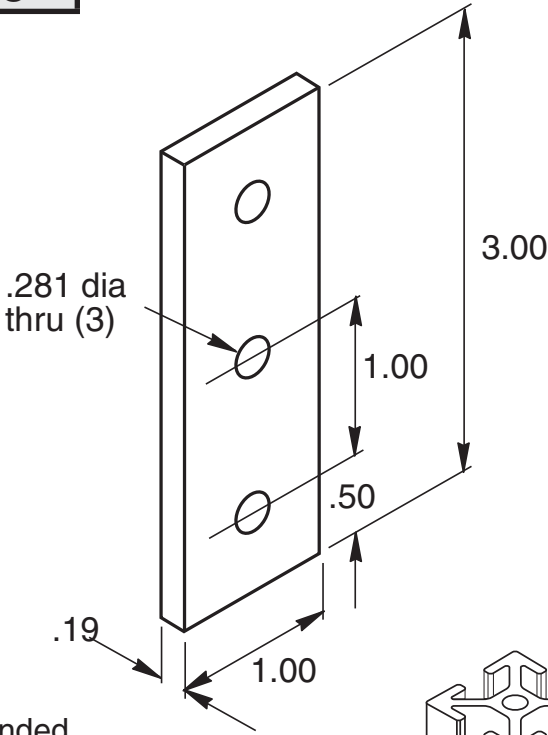

Recommended Hardware  
(3) 11-231 BHCS  
(3) 11-210 T-nut

**1/4" SLOTS**

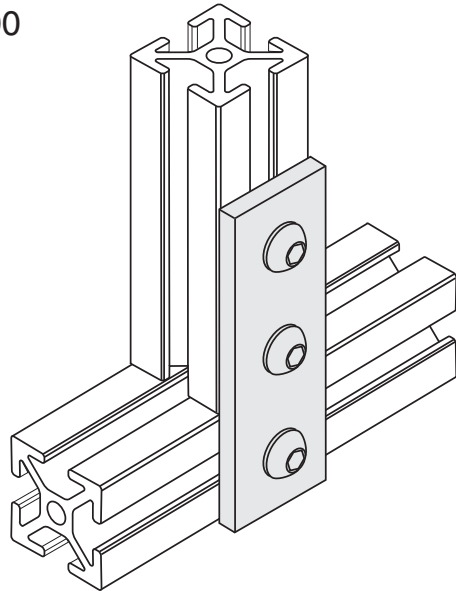

Material - Aluminum  
Finish - Clear Anodize

**11-22**

.281 dia.  
thru (4)

4.00

1.00

.50

Recommended  
Hardware  
(4) 11-231 BHCS  
(4) 11-210 T-nut

.19

1.00

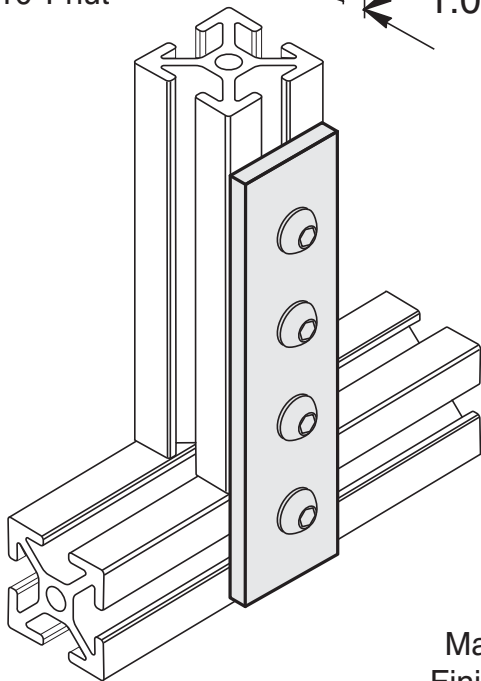

Material - Aluminum  
Finish - Clear Anodize

**1/4" SLOTS**



**11-39**

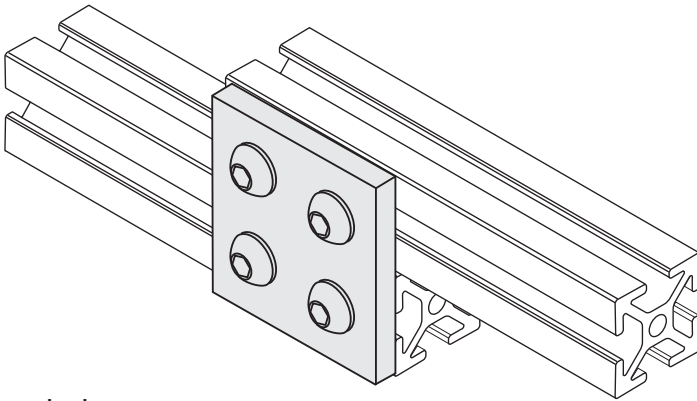
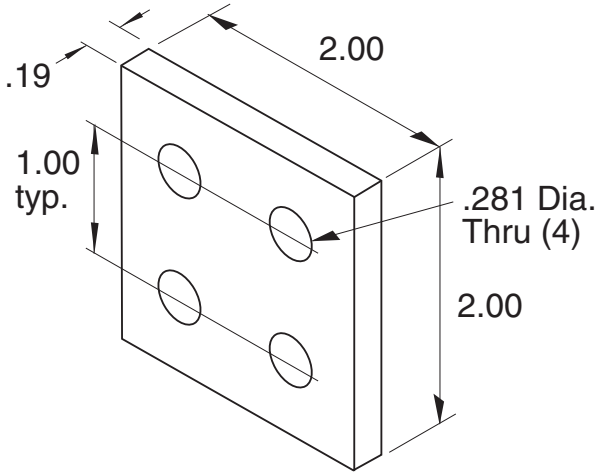

**1/4" SLOTS**

Recommended  
Hardware  
(4) 11-231 BHCS  
(4) 11-210 T-nut

Material - Aluminum  
Finish - Clear Anodize

**11-28**

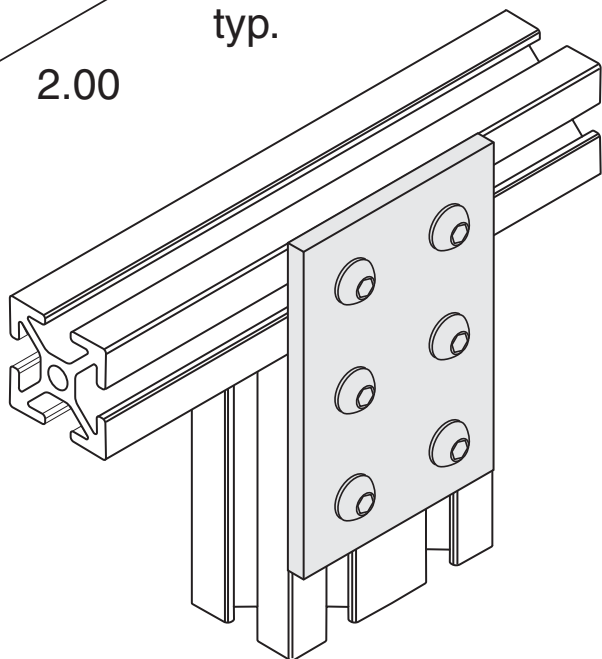
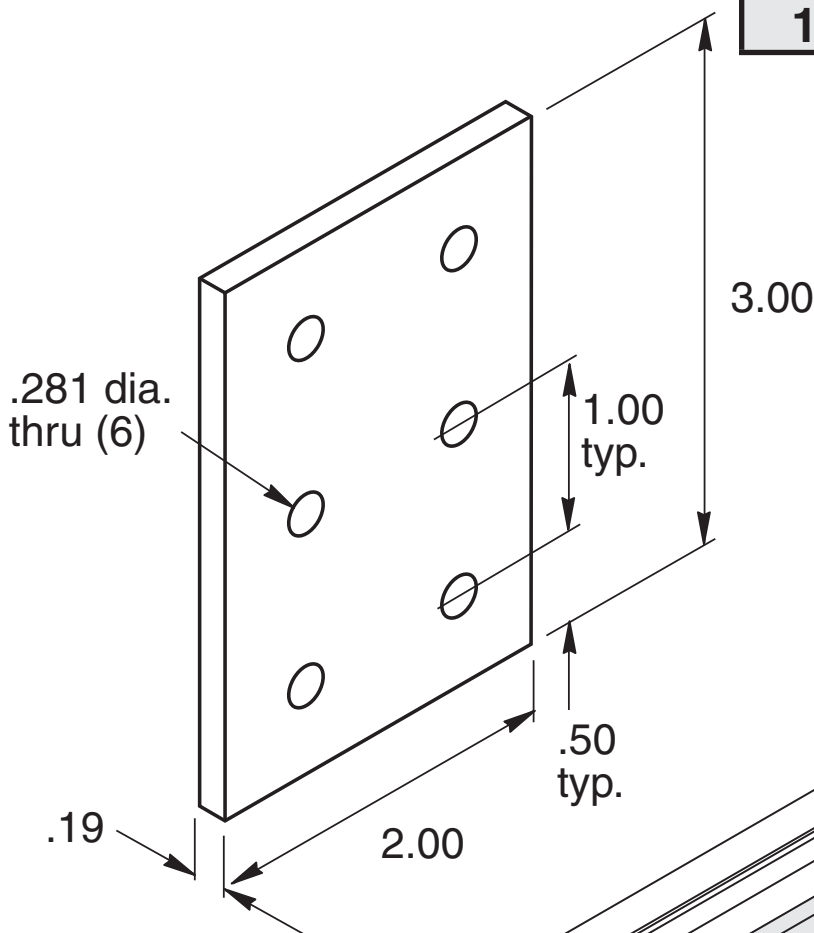

Recommended  
Hardware  
(6) 11-231 BHCS  
(6) 11-210 T-nut

Material - Aluminum  
Finish - Clear Anodize

# Joining Plate



**11-27**

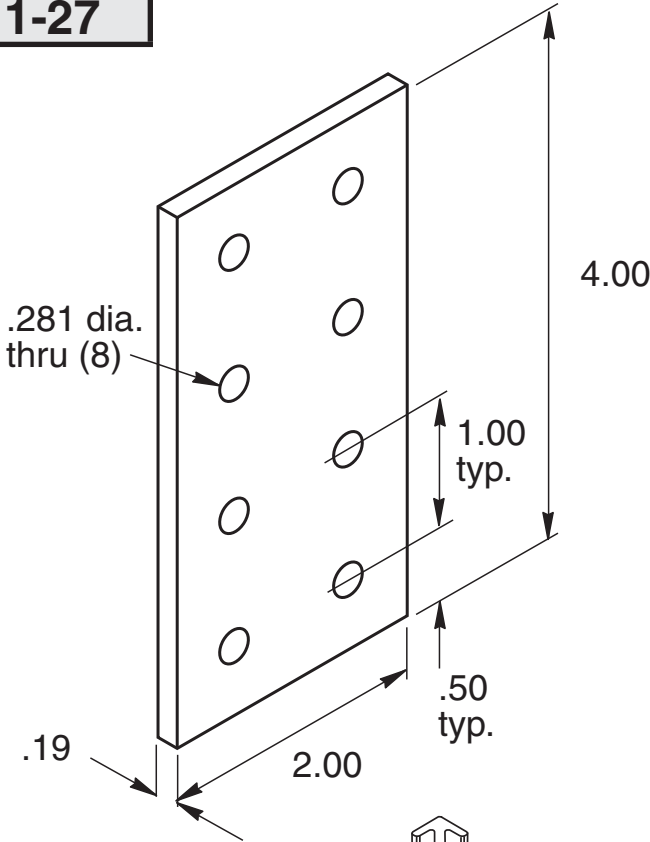

**1/4" SLOTS**

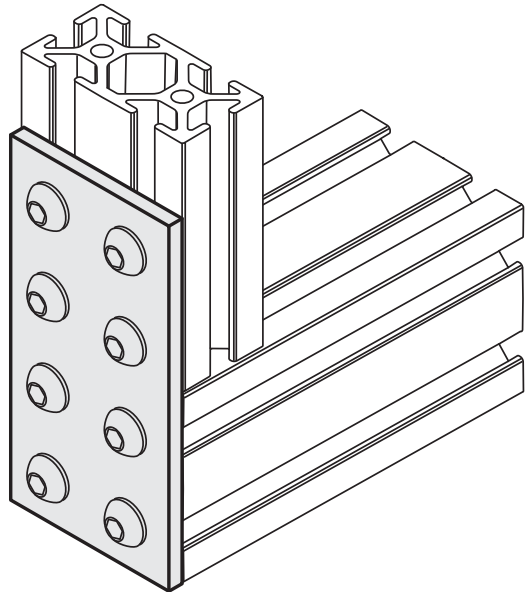

Recommended Hardware  
(8) 11-231 BHCS  
(8) 11-210 T-nut

Material - Aluminum  
Finish - Clear Anodize

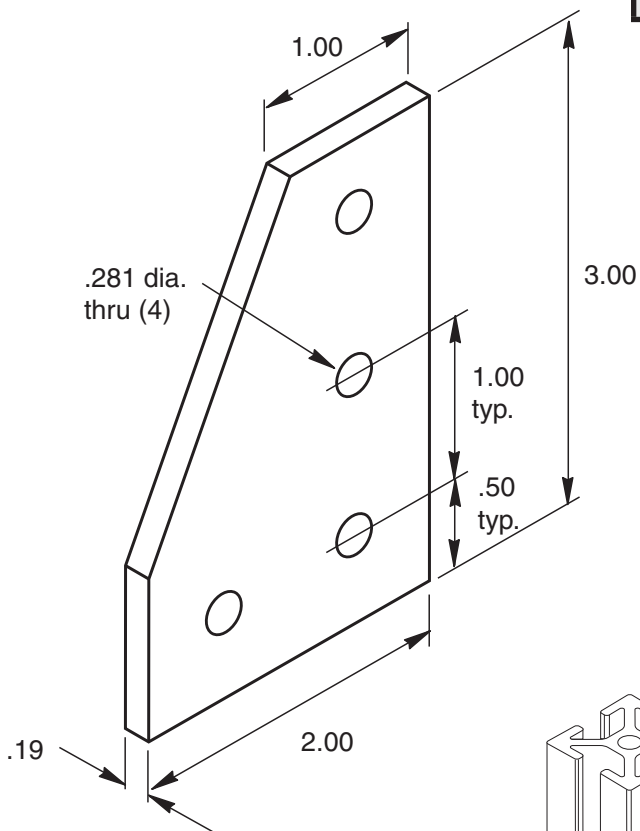

Recommended  
Hardware  
(4) 11-231 BHCS  
(4) 11-210 T-nut

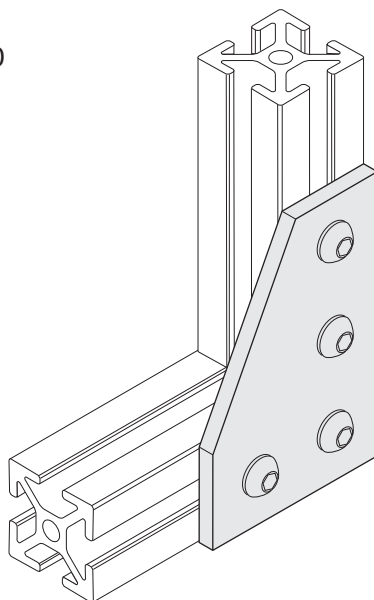

**1/4" SLOTS**

Material - Aluminum  
Finish - Clear Anodize

# Joining Plate



**11-20**

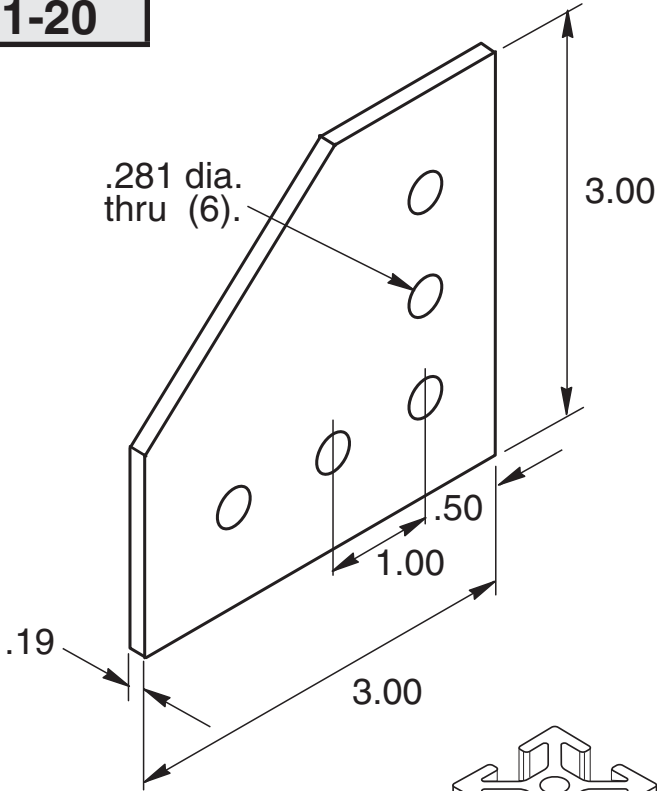

Recommended  
Hardware  
(5) 11-231 BHCS  
(5) 11-210 T-nut

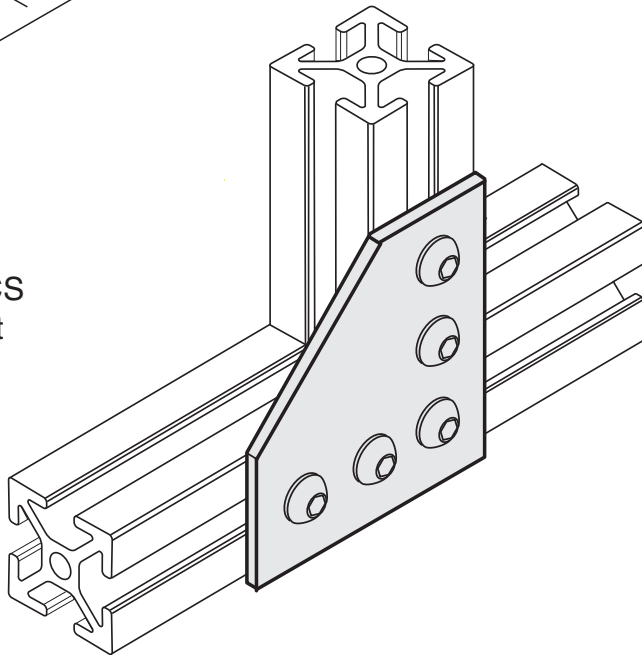

Material - Aluminum  
Finish - Clear Anodize

**1/4" SLOTS**

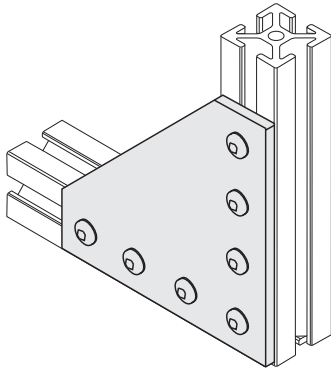
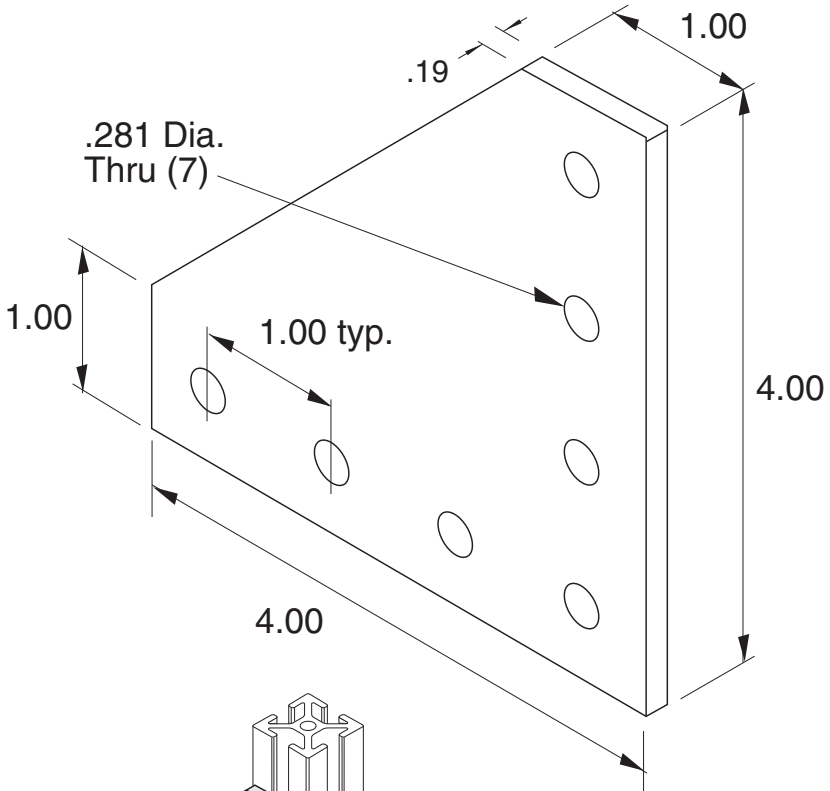

Recommended  
Hardware  
(7) 11-231 BHCS  
(7) 11-210 T-nut

**1/4" SLOTS**

Material - Aluminum  
Finish - Clear Anodize

# Joining Plate



**11-25**

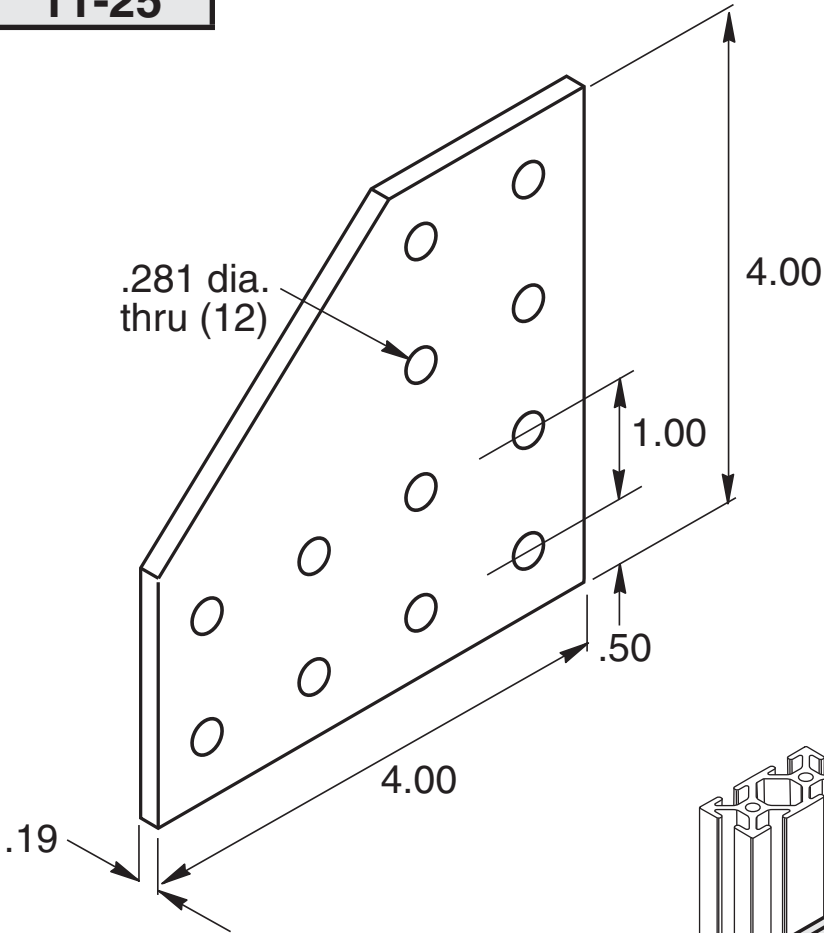

**1/4" SLOTS**

Recommended Hardware  
(12) 11-231 BHCS  
(12) 11-210 T-nut

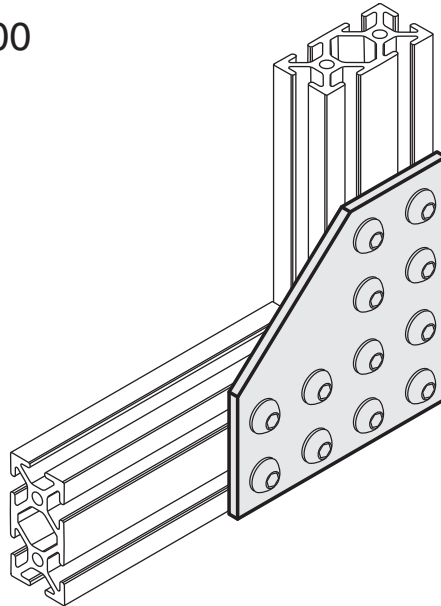

Material - Aluminum  
Finish - Clear Anodize

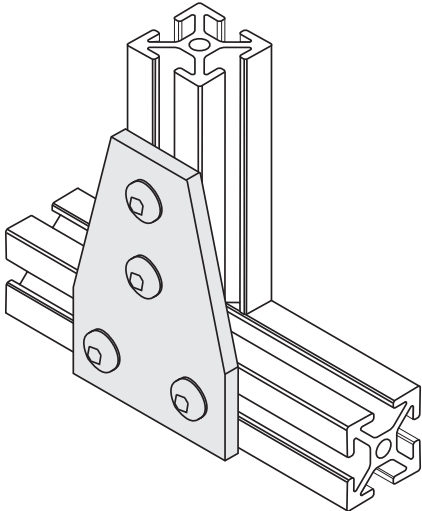
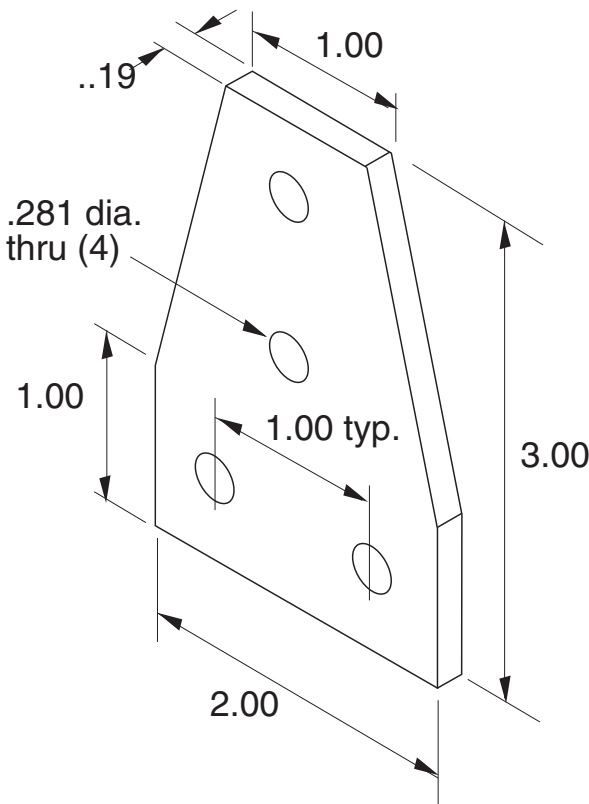

Recommended  
Hardware  
(4) 11-231 BHCS  
(4) 11-210 T-nut

**1/4" SLOTS**

Material - Aluminum  
Finish - Clear Anodize



**11-21**

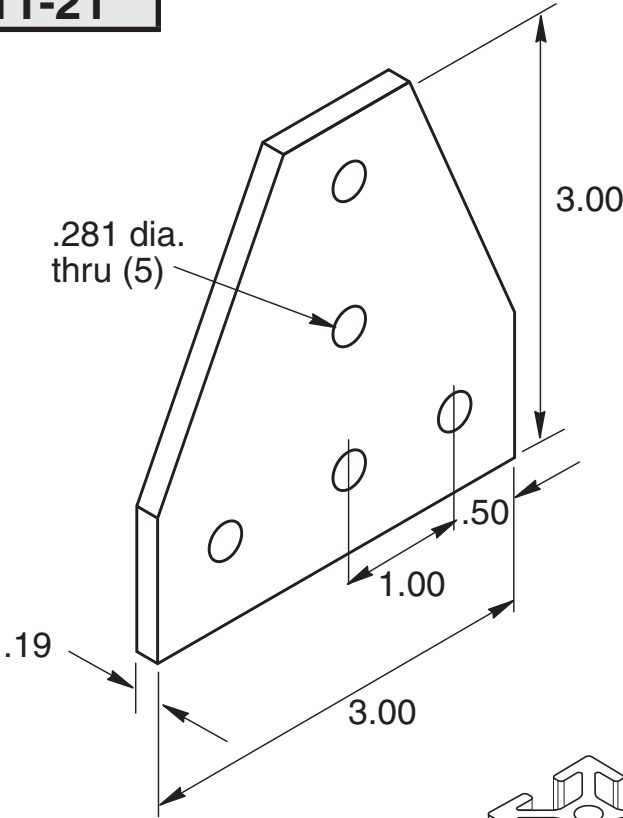

Recommended  
Hardware  
(5) 11-231 BHCS  
(5) 11-210 T-nut

**1/4" SLOTS**

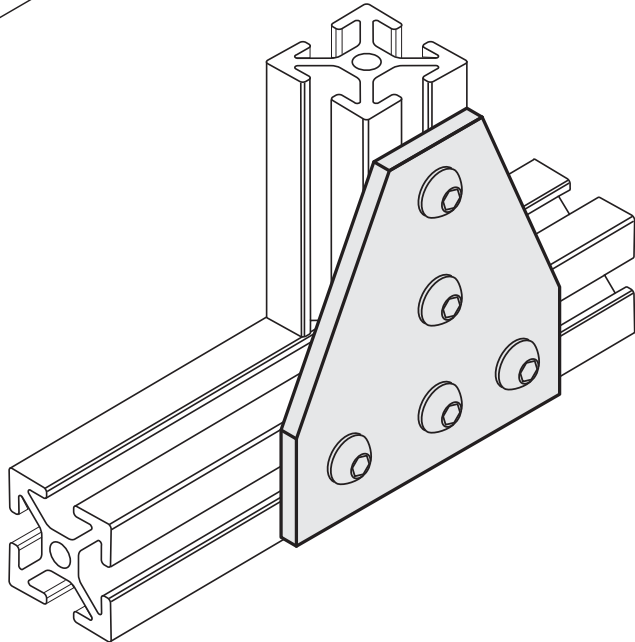

Material - Aluminum  
Finish - Clear Anodize

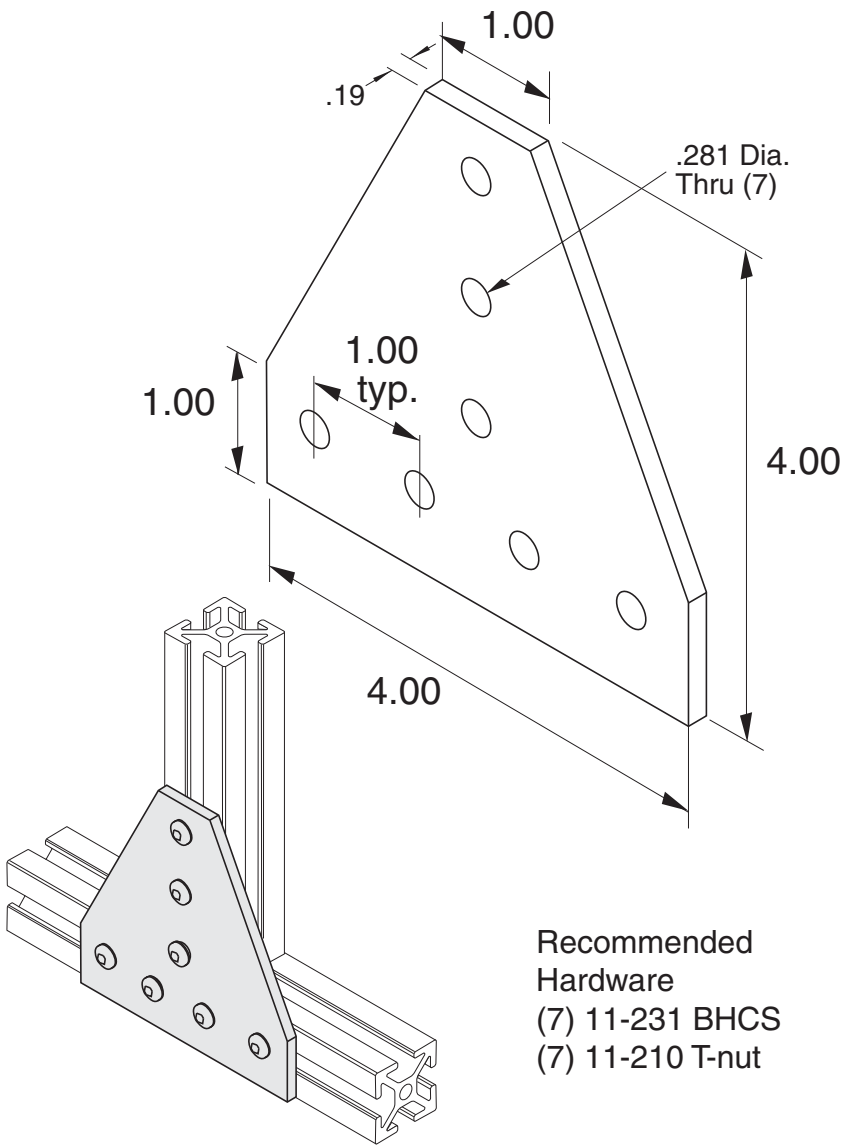

Recommended  
Hardware  
(7) 11-231 BHCS  
(7) 11-210 T-nut

**1/4" SLOTS**

Material - Aluminum  
Finish - Clear Anodize

# Joining Plate



**11-26**

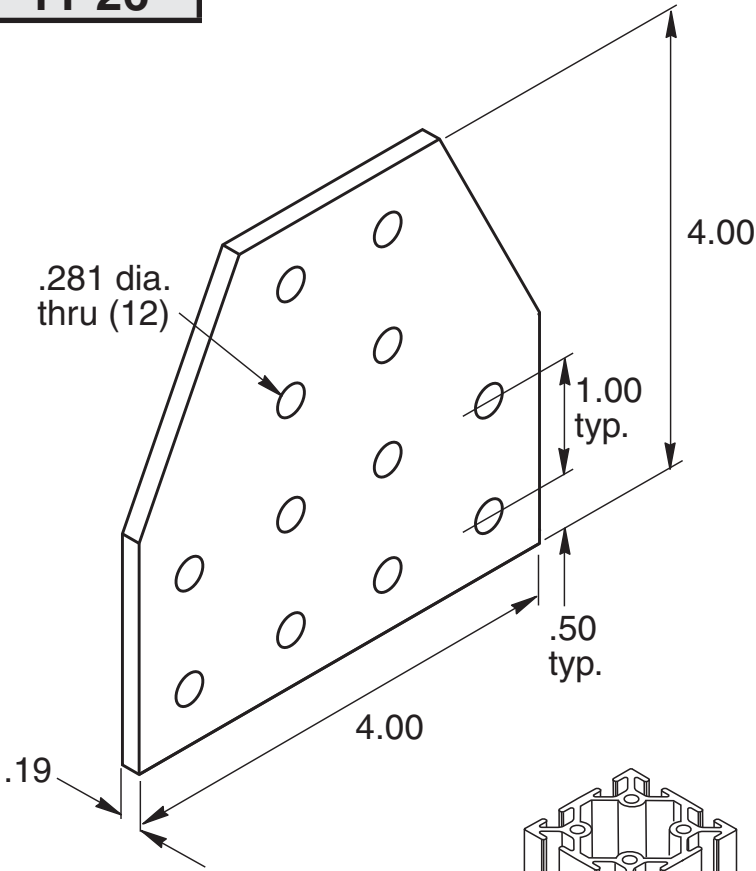

**1/4" SLOTS**

Recommended Hardware  
(12) 11-231 BHCS  
(12) 11-210 T-nut

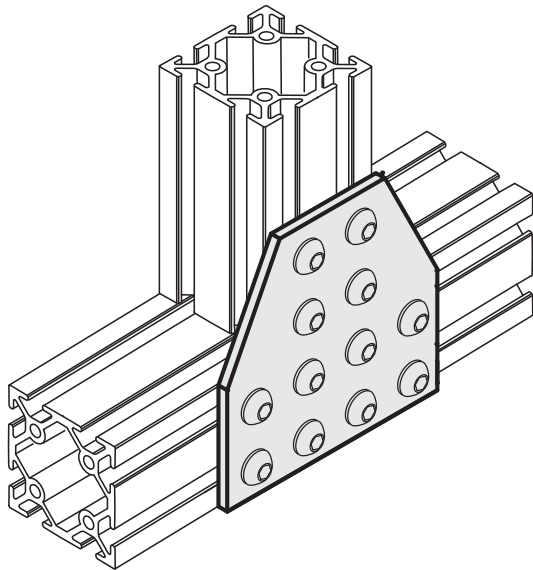

Material - Aluminum  
Finish - Clear Anodize

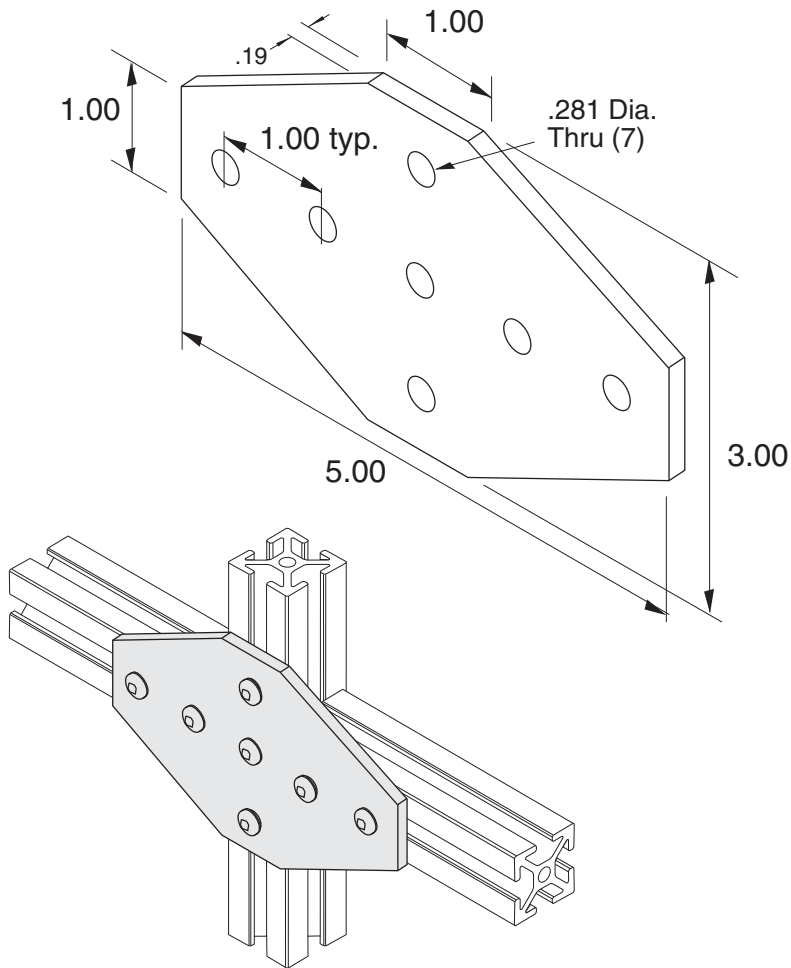

Recommended  
Hardware  
(7) 11-231 BHCS  
(7) 11-210 T-nut

Material - Aluminum  
Finish - Clear Anodize

**1/4" SLOTS**

**11-40**

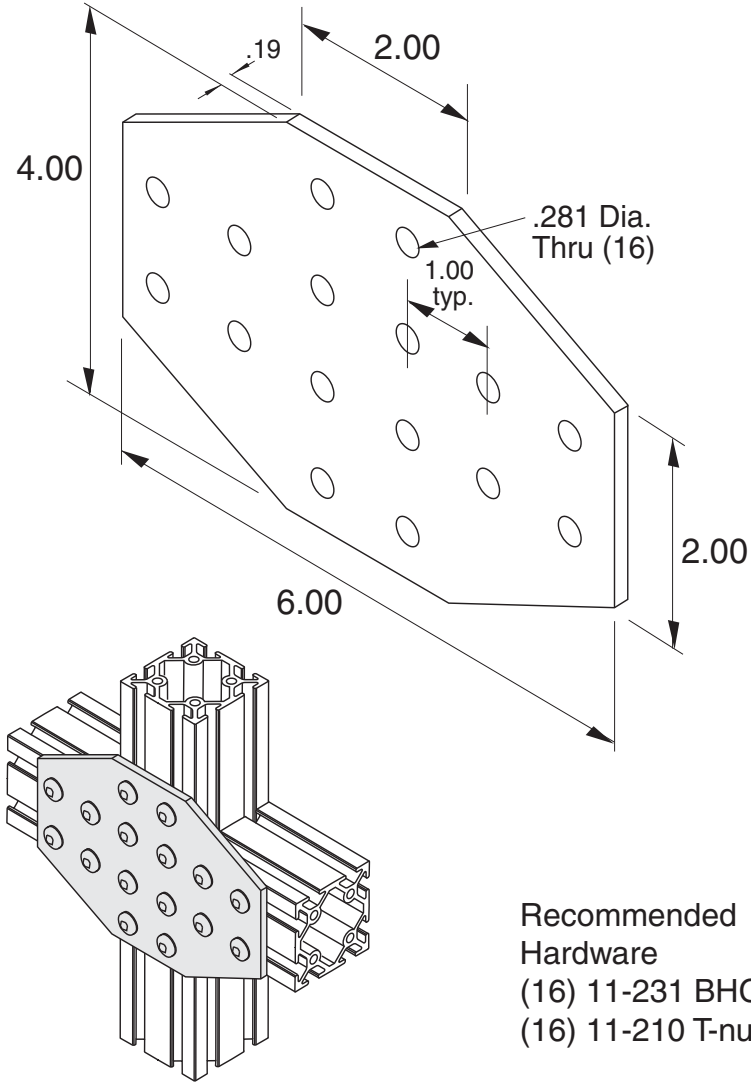

**1/4" SLOTS**

Recommended  
Hardware  
(16) 11-231 BHCS  
(16) 11-210 T-nut

Material - Aluminum  
Finish - Clear Anodize

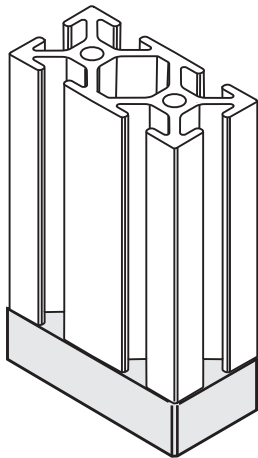

**11-45A** 3/8-16 UNC thru  
**11-45B** 1/2-13 UNC thru

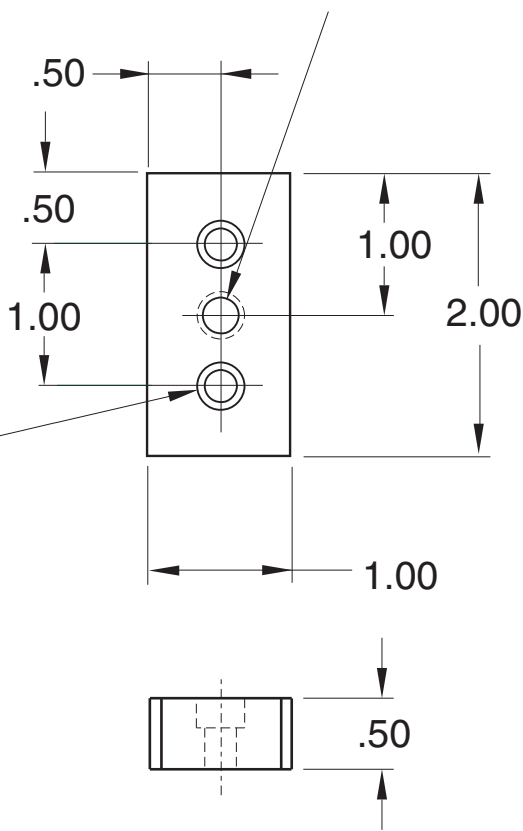

Drilled & C'Bored  
 for 1/4-20 SHCS  
 (2) plc's

Recommended  
 Hardware  
 (2) 11-223 SHCS

Material - Aluminum  
 Finish - Clear Anodize

**1/4" SLOTS**

# Leveling Anchor Plate



**11-48**

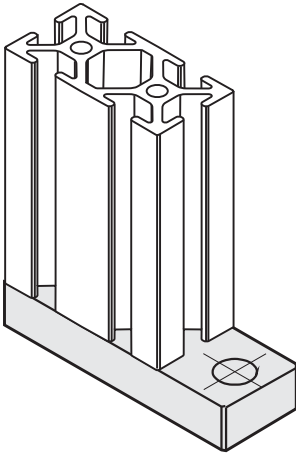

**11-48A** 3/8-16 UNC thru  
**11-48B** 1/2-13 UNC thru

Drilled & C'Bored  
for 1/4-20 SHCS  
(2) plcs

7/16" Dia. thru  
for floor anchor

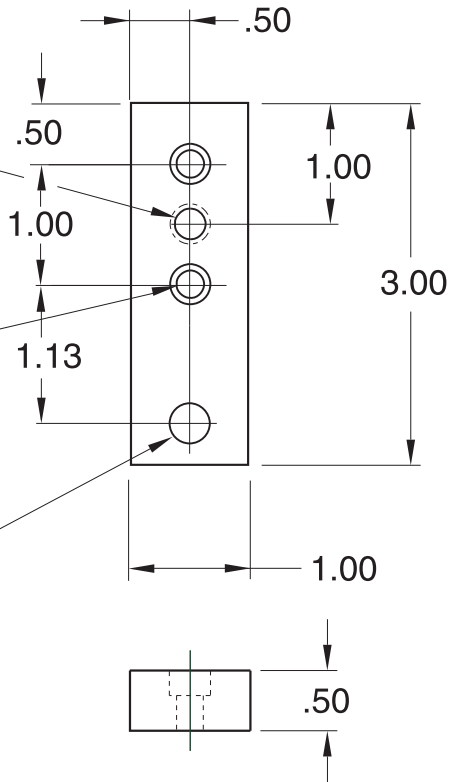

Recommended  
Hardware  
(2) 11-223 SHCS

Material - Aluminum  
Finish - Clear Anodize

1/4" SLOTS

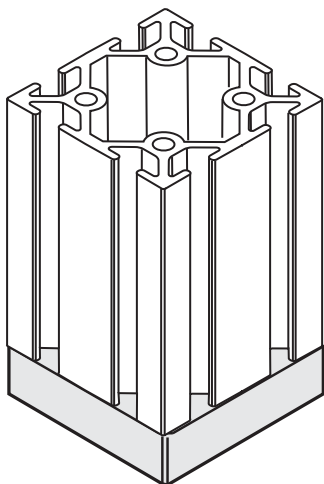

**11-46A** 3/8-16 UNC thru  
**11-46B** 1/2-13 UNC thru

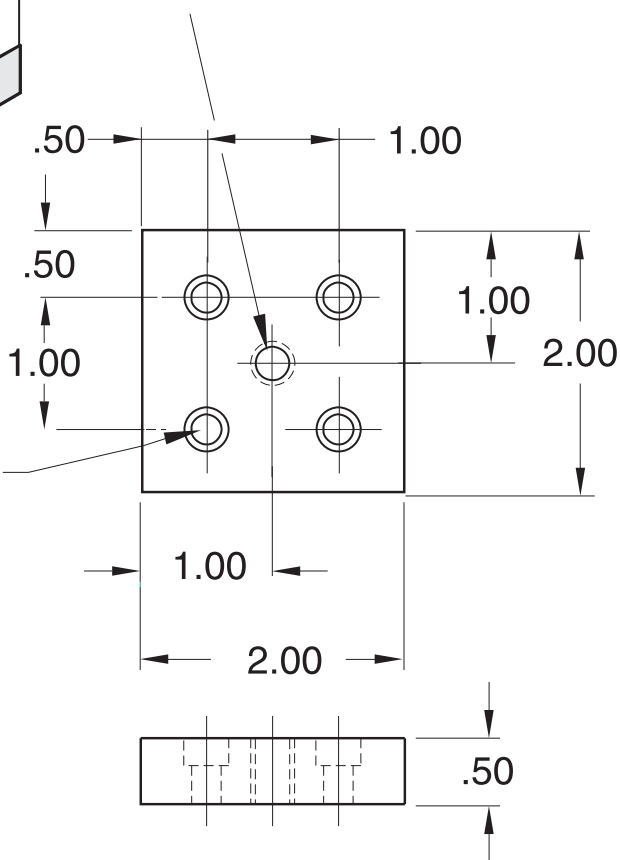

Drilled & C'Bored  
 for 1/4-20 SHCS  
 (4) plc's

Recommended  
 Hardware  
 (4) 11-223 SHCS

Material - Aluminum  
 Finish - Clear Anodize



# Leveling Anchor Plate



**11-47**

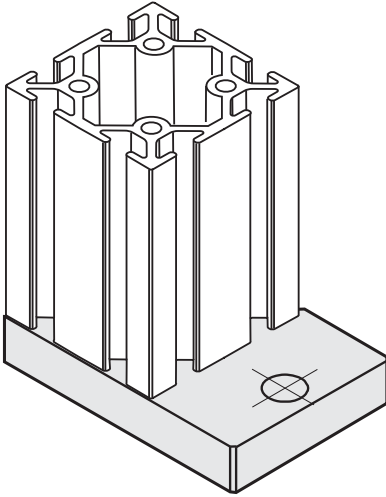

**11-47A** 3/8-16 UNC thru  
**11-47B** 1/2-13 UNC thru

Drilled & C'Bored  
for 1/4-20 SHCS  
(4) plc's

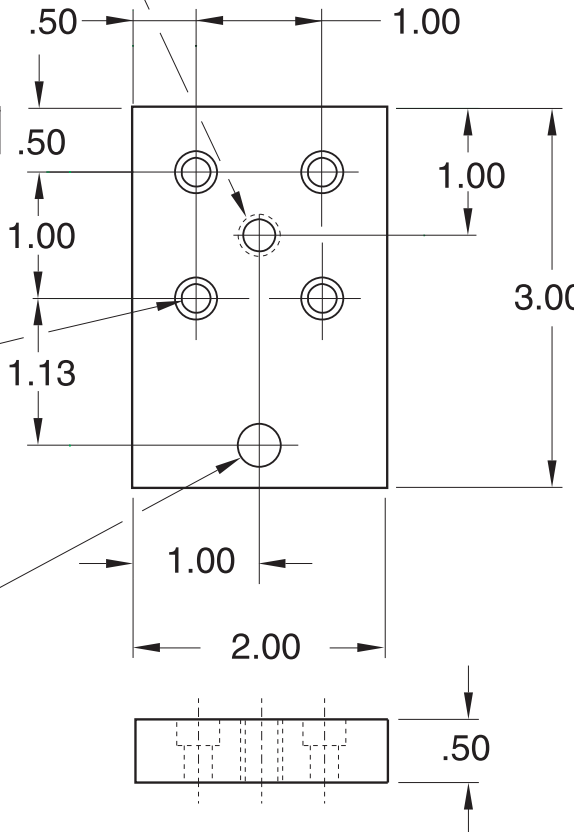

7/16 Dia. thru  
for floor anchor

**1/4" SLOTS**

Recommended  
Hardware  
(4) 11-223 SHCS

Material - Aluminum  
Finish - Clear Anodize

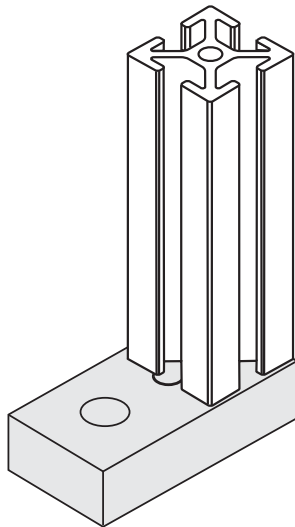
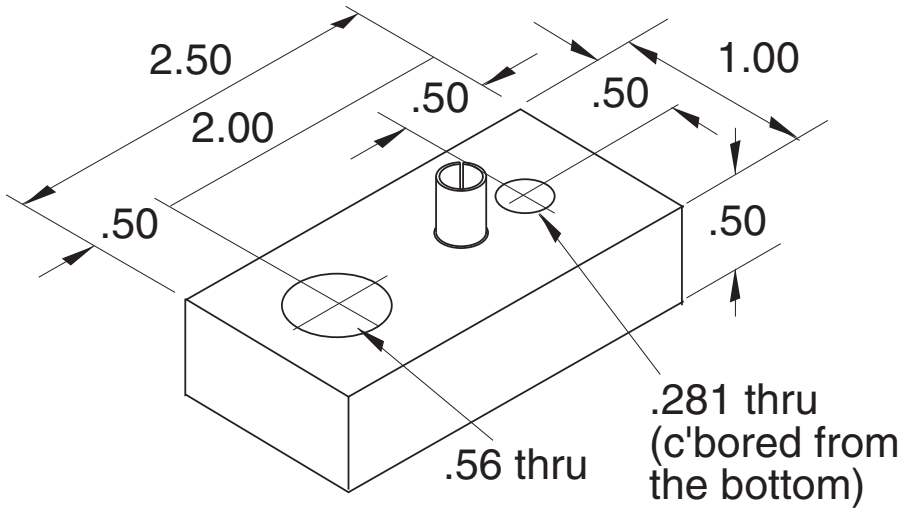

Recommended  
Hardware  
(1) 11-223 SHCS

Material - Aluminum  
Finish - Clear Anodize

**1/4" SLOTS**

**11-49**

**11-49A** 3/8-16 UNC tap thru  
**11-49B** 1/2-13 UNC tap thru

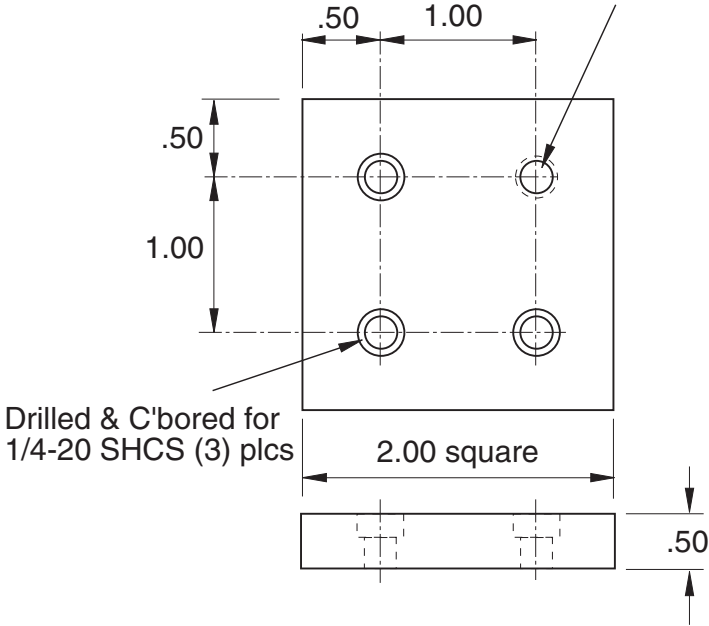

**1/4" SLOTS**

Recommended  
Hardware  
(3) 11-221 SHCS  
(3) 11-210 T-nut

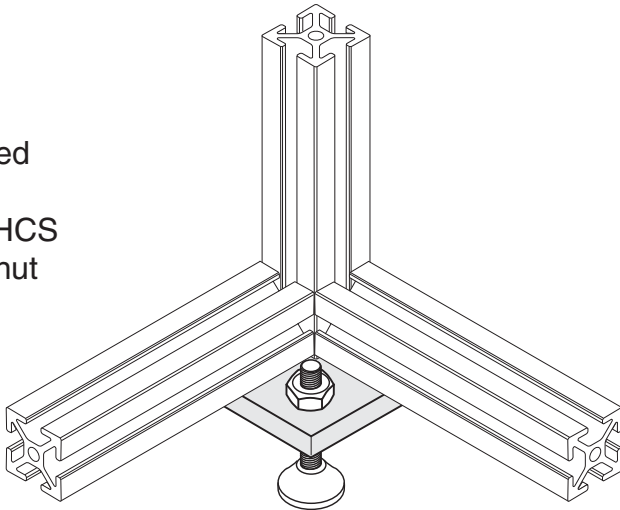

Material - Aluminum  
Finish - Clear Anodize

**EC-S1**

**EC-S2**

**EC-S3**

EX-12

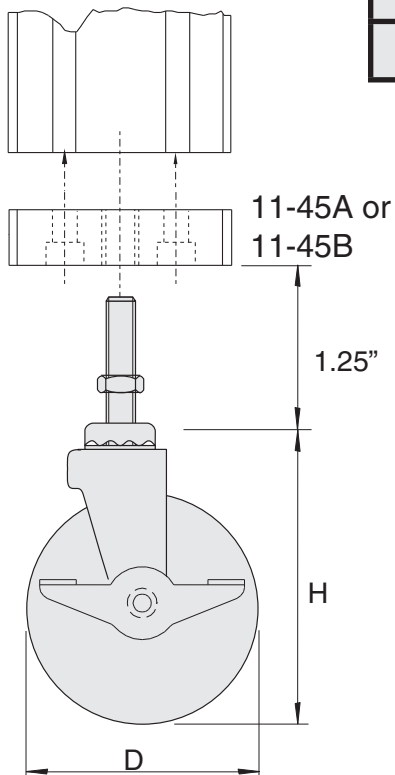

**EC-S1**

**EC-S2**

**EC-S3**

Note: Wheel material is hard plastic

Part no.	D	H	Stem	Brake	Max. Load	Wheel Width
<b>EC-S1</b>	2	2 7/8	3/8-16 x 1 1/4	Yes	125 lbs	1.00
<b>EC-S2</b>	3	3 3/4	3/8-16 x 1 1/4	Yes	250 lbs	1.25
<b>EC-S3</b>	4	5	1/2-13 x 1 1/2	Yes	300 lbs	1.25

**1/4" SLOTS**

# Swivel Plate Caster w/brake



<b>11-110</b>
<b>11-111</b>
<b>11-112</b>

EX-22 uses caster plate 11-50

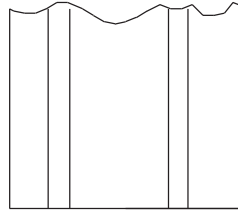

EX-22

The casters have (4) .343 dia mtg. holes on 1 3/4" x 3.00" centers

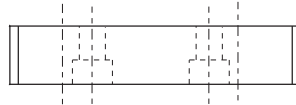

11-50

Recommended Hardware  
(4) EF-12-.5 BHCS

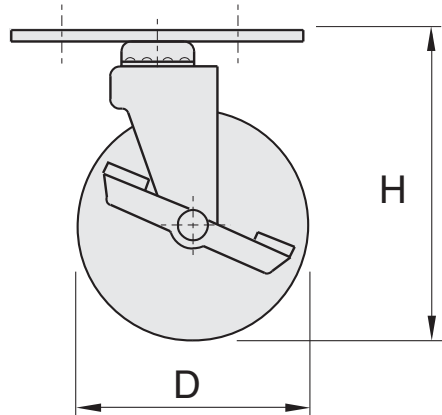

**1/4" SLOTS**

Note: Wheel material is hard plastic

Part no.	D	H	Brake	Max. Load	Wheel Width
<b>11-110</b>	3"	4.13	Yes	250 lbs	1.25
<b>11-111</b>	4"	5.00	Yes	300 lbs	1.25
<b>11-112</b>	5"	6.00	Yes	325 lbs	1.25

<b>11-120</b>
<b>11-121</b>
<b>11-122</b>

EX-22 uses caster plate 11-50

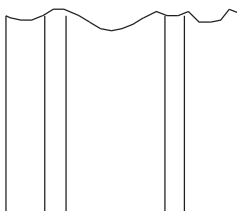

EX-22

The casters have (4) .343 dia mtg. holes on 1 3/4" x 3.00" centers

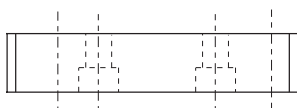

11-50

Recommended Hardware  
(4) EF-12-.50 BHCS

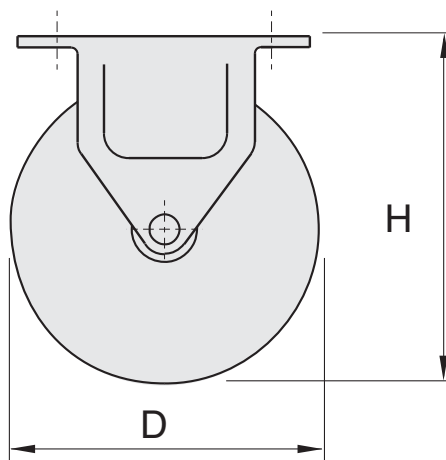

Note: Wheel material is hard plastic

Part no.	D	H	Brake	Max. Load	Wheel Width
<b>11-120</b>	3"	4.13	No	250 lbs	1.25
<b>11-121</b>	4"	5.00	No	300 lbs	1.25
<b>11-122</b>	5"	6.00	No	325 lbs	1.25

**1/4" SLOTS**

**11-50**

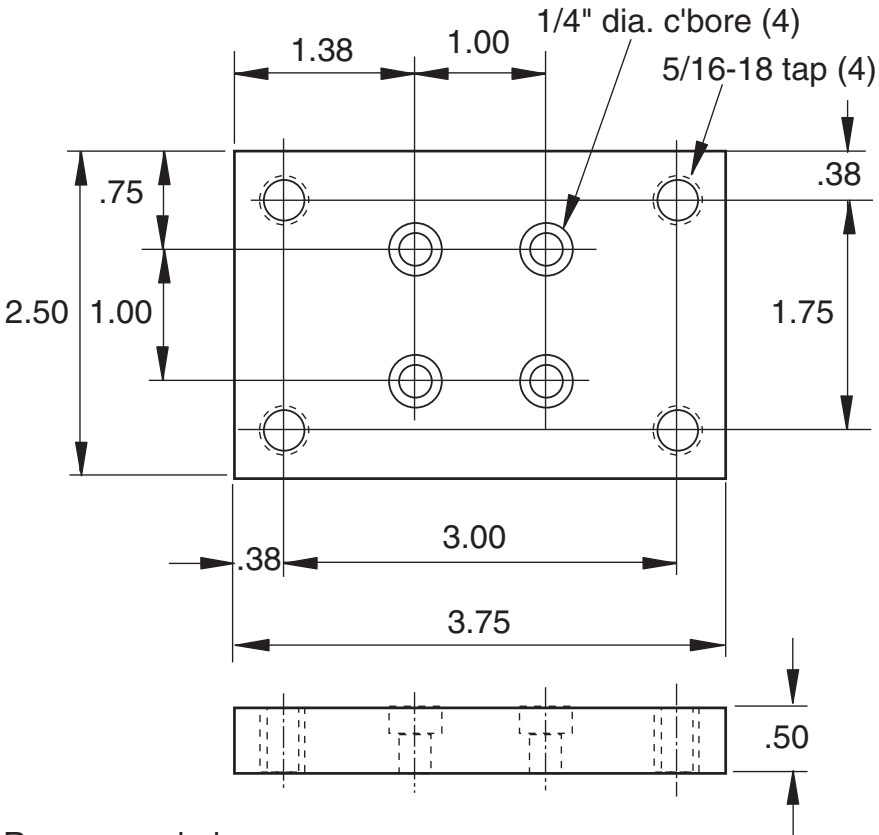

**1/4" SLOTS**

Recommended Hardware

- (4) 11-221 SHCS for extrusion end mounting
- or
- (4) 11-223 SHCS for extrusion slot mounting
- (4) 11-210 T-nut

For Casters, See Pages 427 & 428

Material - Aluminum  
 Finish - Clear Anodize

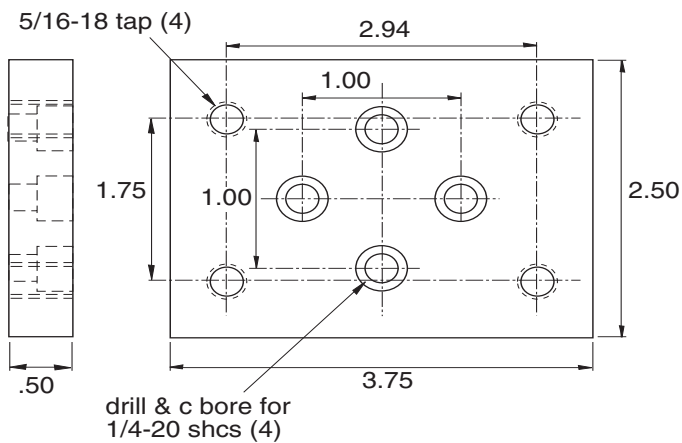

Recommended  
Hardware  
(4) 11-221 SHCS  
(4) 11-210 T-nut

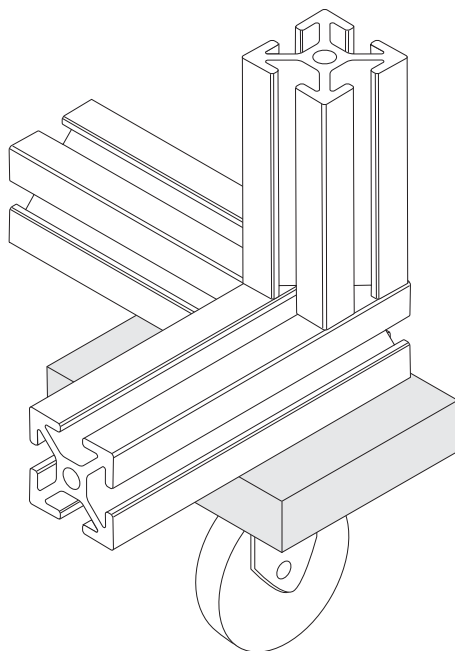

**1/4" SLOTS**

Material - Aluminum  
Finish - Clear Anodize



**11-270**

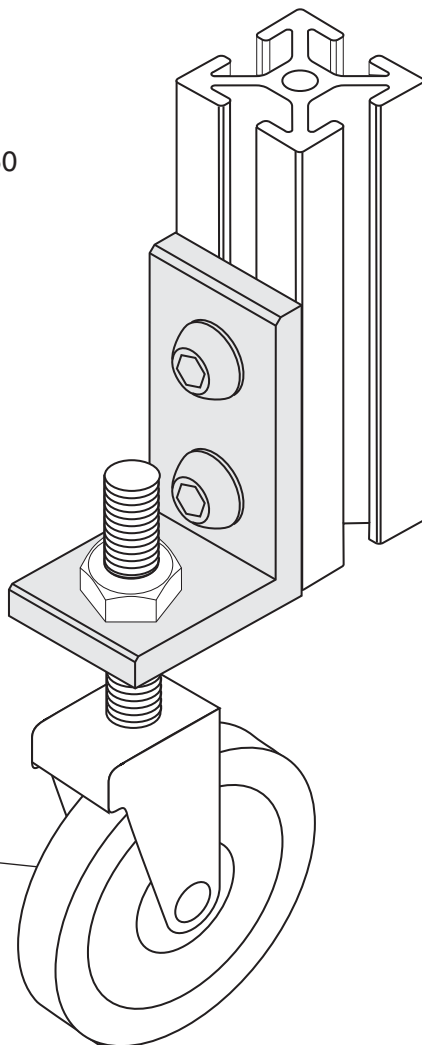
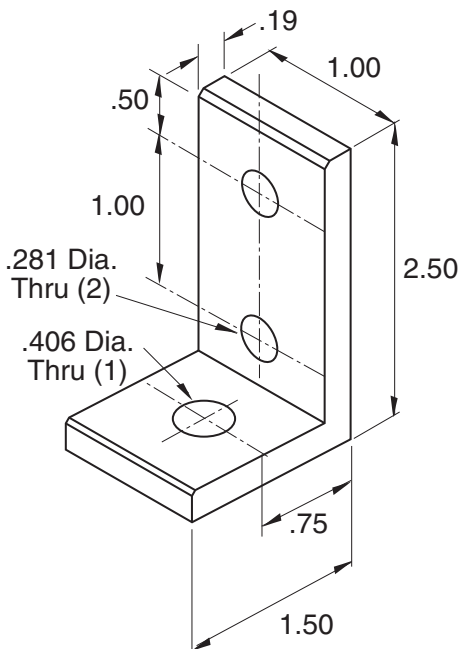

Recommended  
Hardware  
(2) 11-221 SHCS  
(2) 11-210 T-nut

**1/4" SLOTS**

EC-S1  
EC-S2

Material - Steel  
Finish - Black Powder Coat

**11-35**

**11-36**

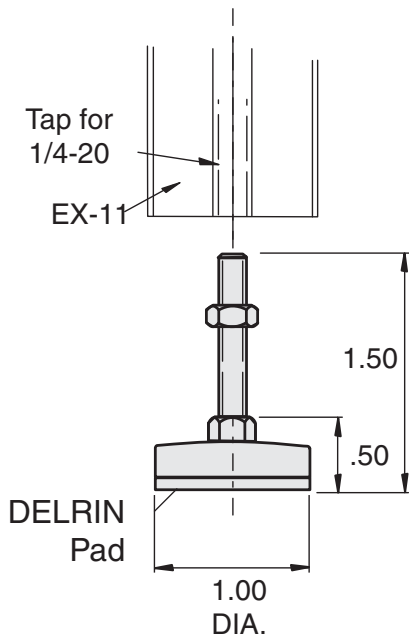

Load = 100 lbs

**11-35**

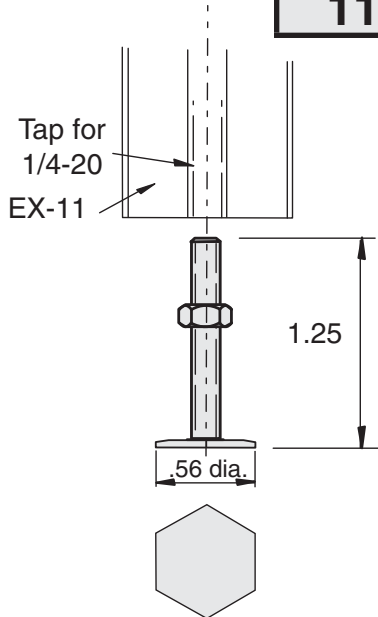

Load = 150 lbs

**11-36**

Material - Steel

**Deluxe Leg**

**11-52**

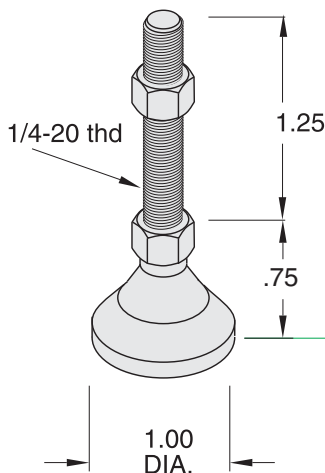

Load = 2000 lbs

**1/4" SLOTS**

# Steel Flanged Foot



**11-70**

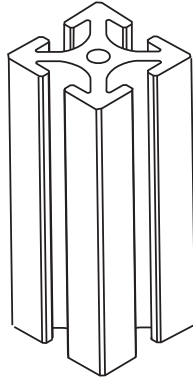

use with EX-11

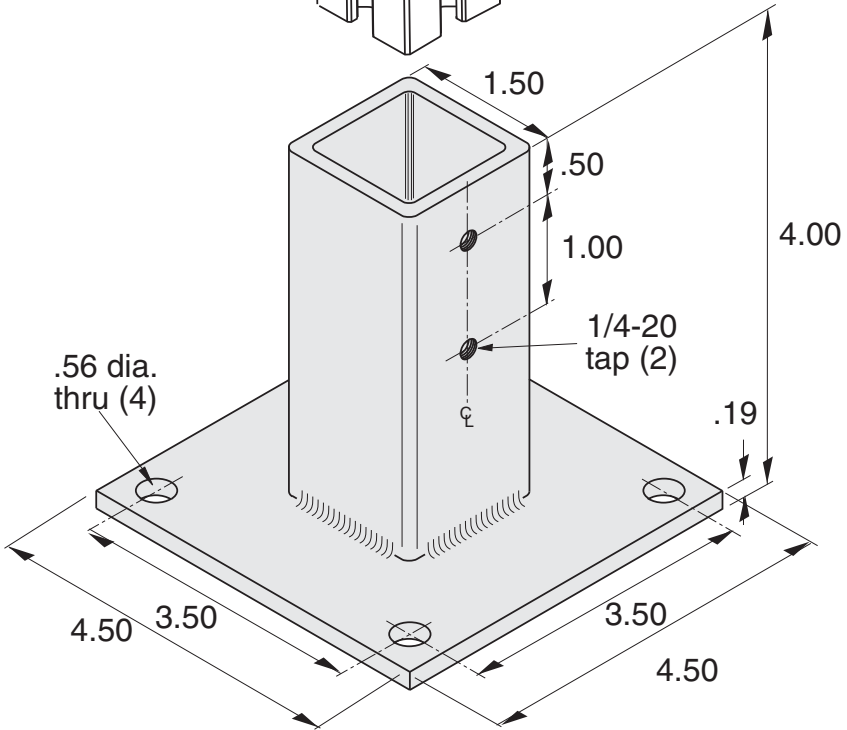

1/4" SLOTS

Recommended Hardware  
(2) 11-223 SHCS

Material - Steel  
Finish - Black Powder Coat

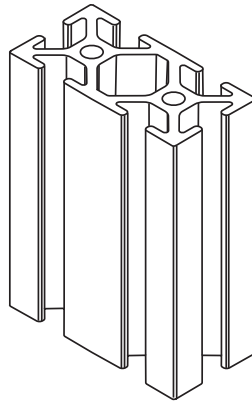

use with EX-12

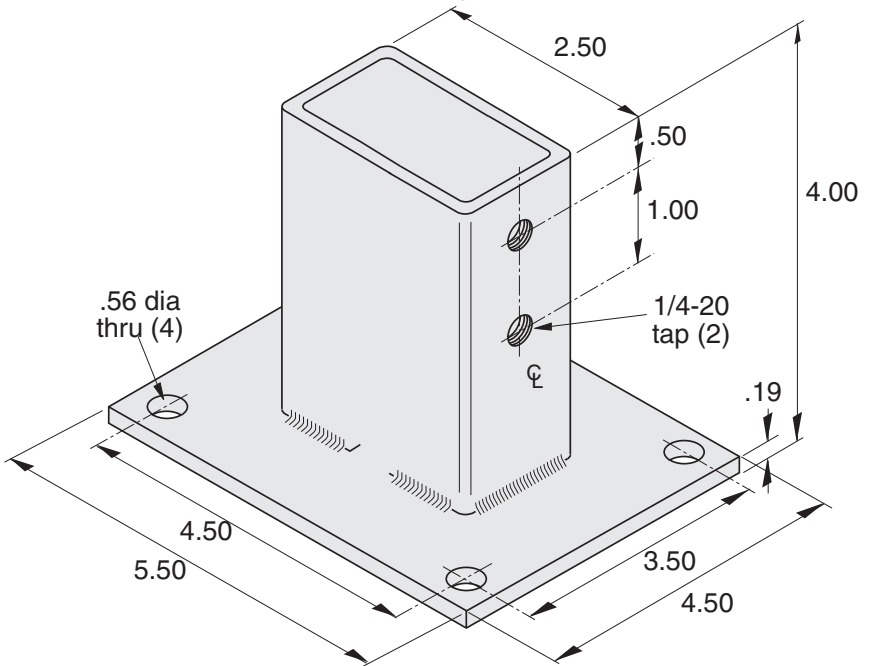

**1/4" SLOTS**

Recommended  
Hardware  
(2) 11-223 SHCS

Material - Steel  
Finish - Black Powder Coat

# Steel Flanged Foot



**11-72**

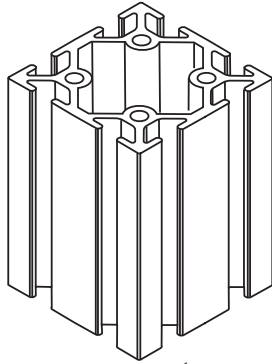

use with  
EX-22

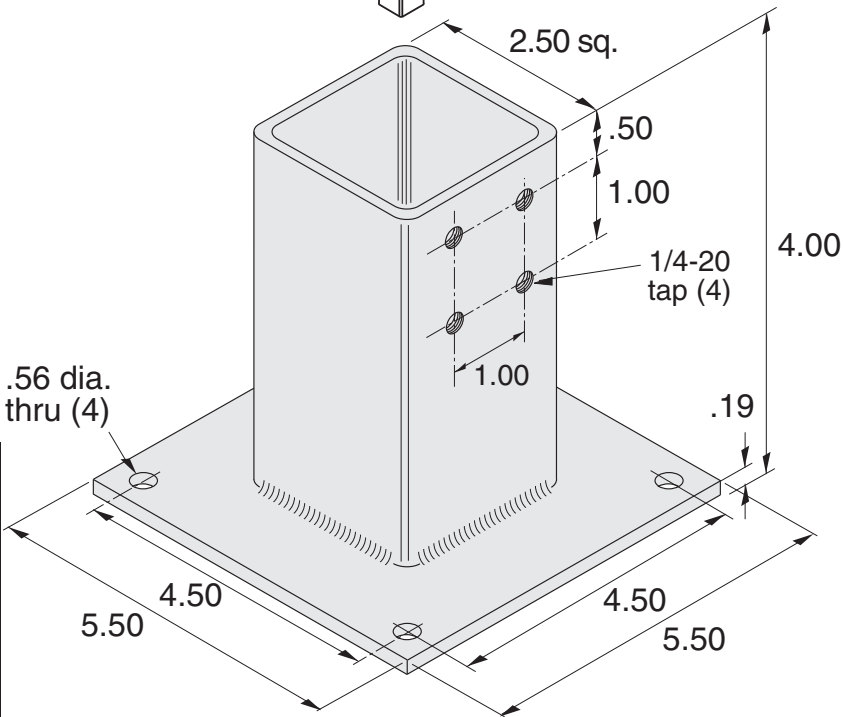

Recommended  
Hardware  
(4) 11-223 SHCS

Material - Steel  
Finish - Black Powder Coat

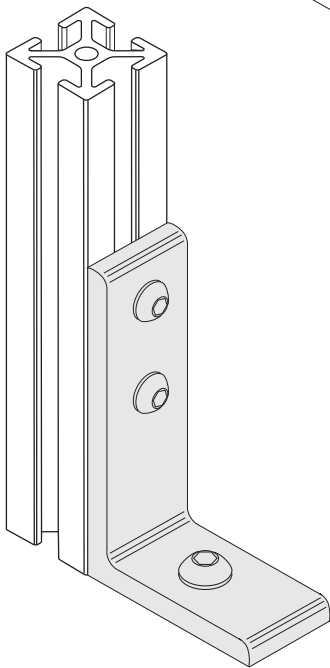
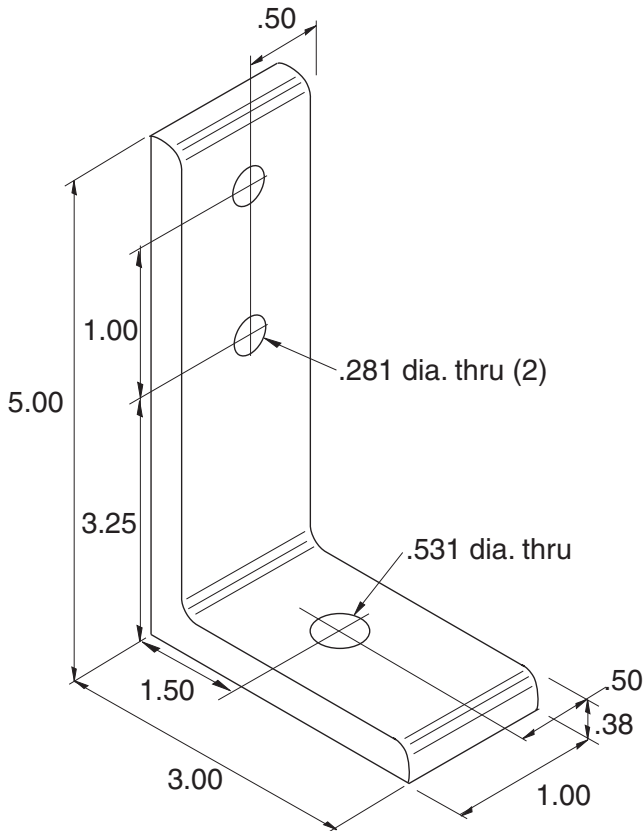

**Recommended  
Hardware**  
(2) 11-232 BHCS  
(2) 11-205 T-nut

**Material - Aluminum  
Finish - Clear Anodize**

**1/4" SLOTS**

# Economy Aluminum Floor Mount



**11-74**

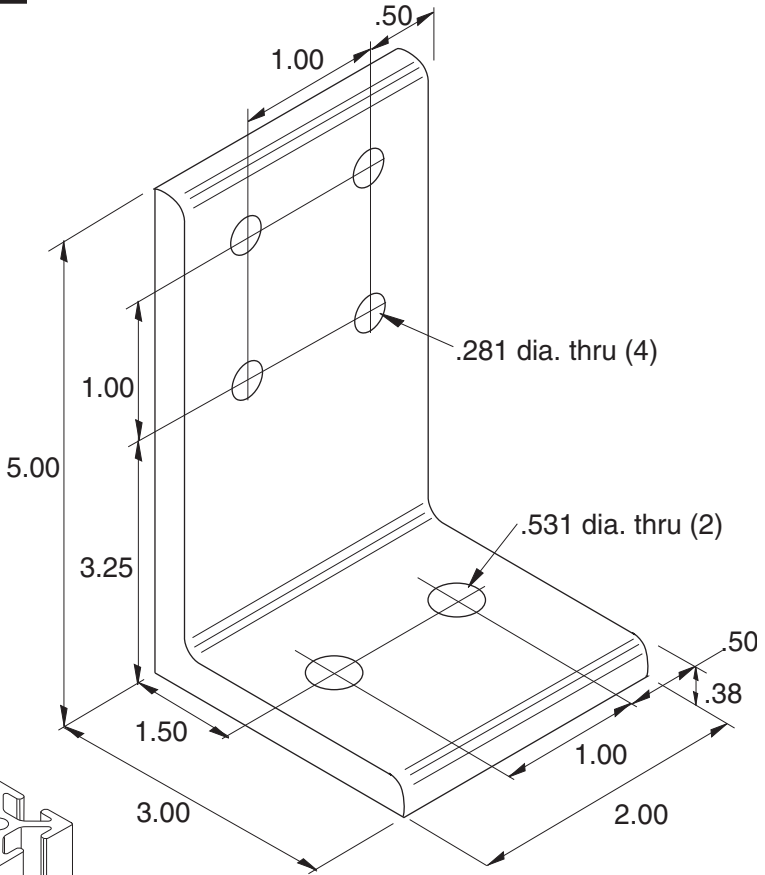

**1/4" SLOTS**

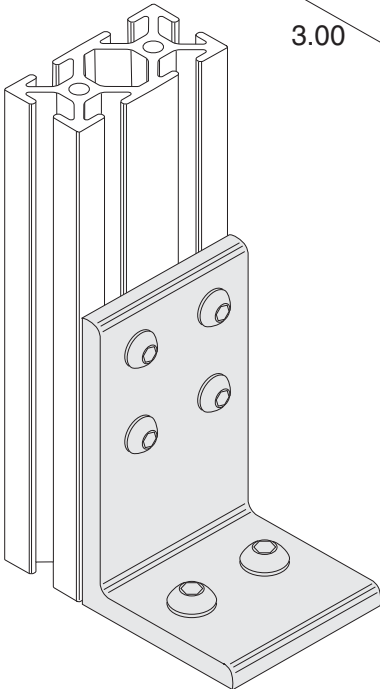

**Recommended Hardware**  
(4) 11-232 BHCS  
(4) 11-205 T-nut

**Material - Aluminum**  
**Finish - Clear Anodize**

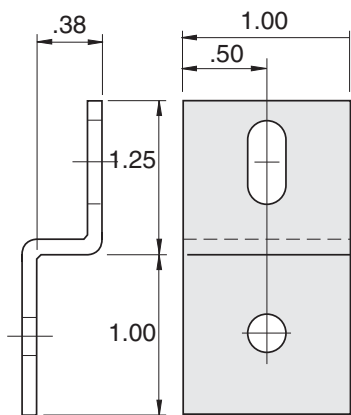

EB-38-1 or  
EB-38-1/2

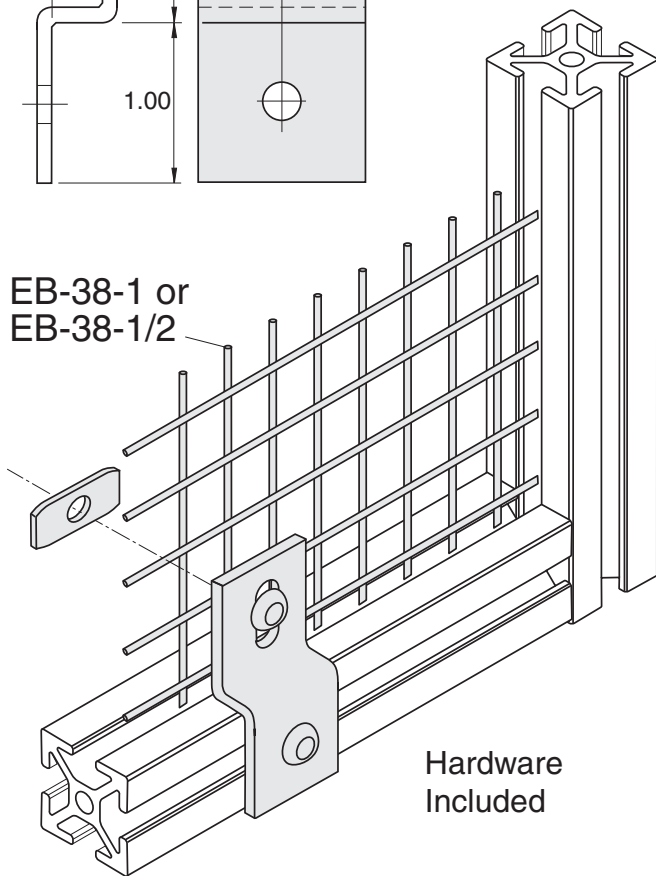

Hardware  
Included

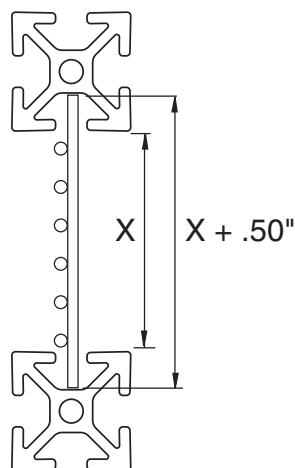

Cut wire  
mesh to  
X + .50"

**1/4" SLOTS**

Material - Steel  
Finish -Black Powder Coat



**11-31**

EB-38-1 or  
EB-38-1/2

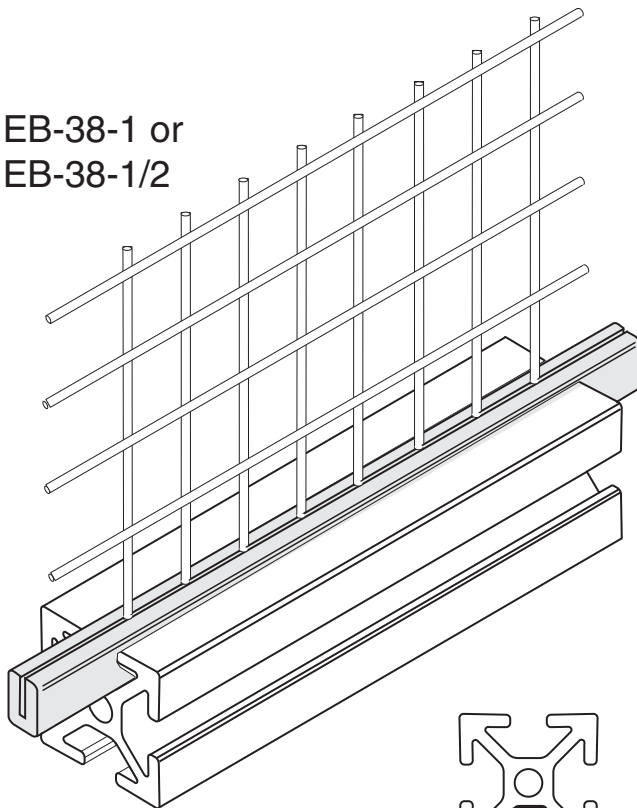

Note: Provides snug fit

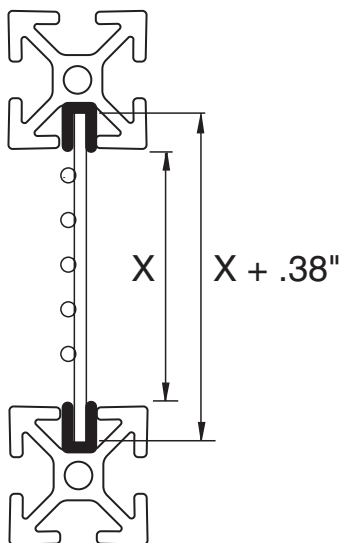

Cut wire mesh  
to  $X + .38''$

**1/4" SLOTS**

**Upper Door Slide (3 track)**

**11-32**

**Lower Door Slide (3 track)**

**11-33**

**11-32**

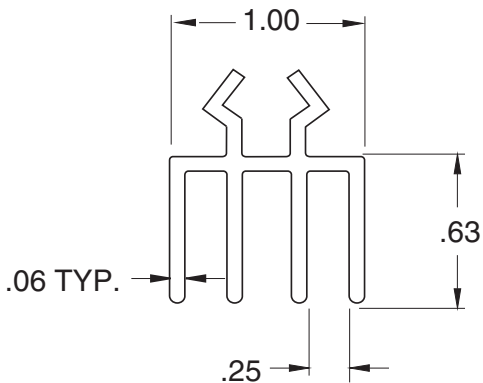

Material - Rigid PVC

Sold in 6 foot lengths



cut panels  
to X - 1/2"

X

**11-33**

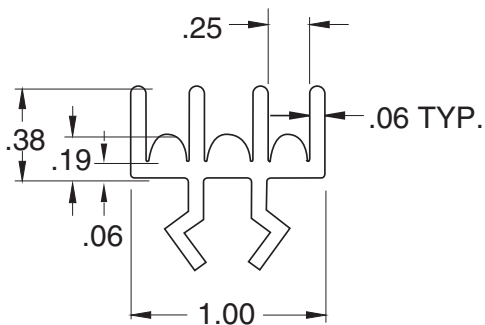

Cut Panels  
to X - 1/2"

**1/4" SLOTS**

Sold in 6 foot lengths

Material - Rigid PVC

# T-Slot Cover



11-245
11-246
11-247
11-244

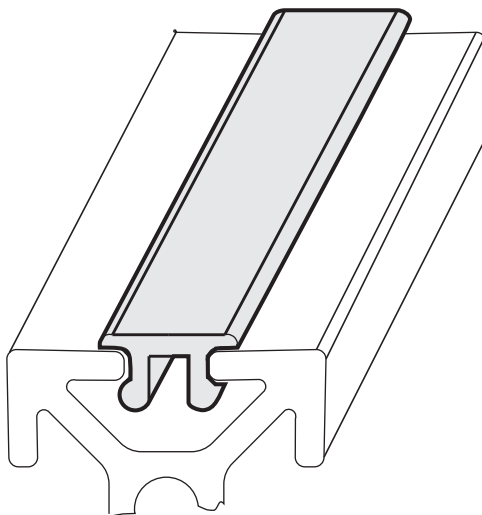

<b>Part No.</b>	
11-244	Safety Orange
11-245	Gray
11-246	Black
11-247	Yellow

Sold in 6 ft. lengths

Material - Rigid PVC

1/4" SLOTS



3/16" (.17 actual)

Note: Install panel, then gasket

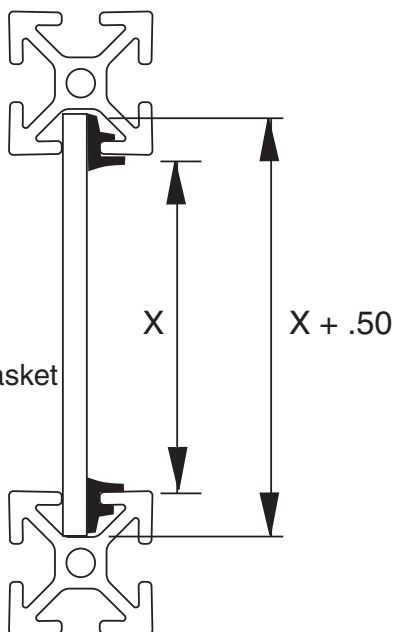

Cut panel to X + .50"

1/4" SLOTS

Material - Black Flexible PVC

# Plastic Panel Retaining Gasket



<b>11-298</b>	<b>3/16" for .170 thick panels</b>
<b>11-299</b>	<b>1/8" for .125 thick panels</b>

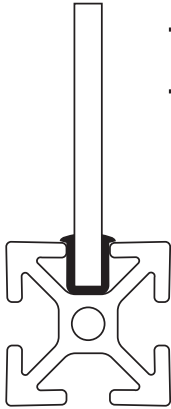

**11-298** for .170 thick panels

**11-299** for .125 thick panels

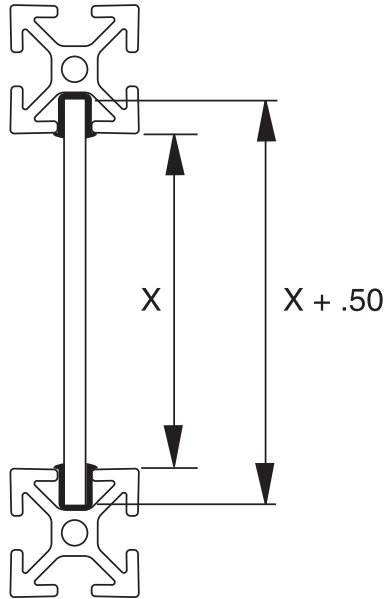

Cut panel to  $X + .50$ "

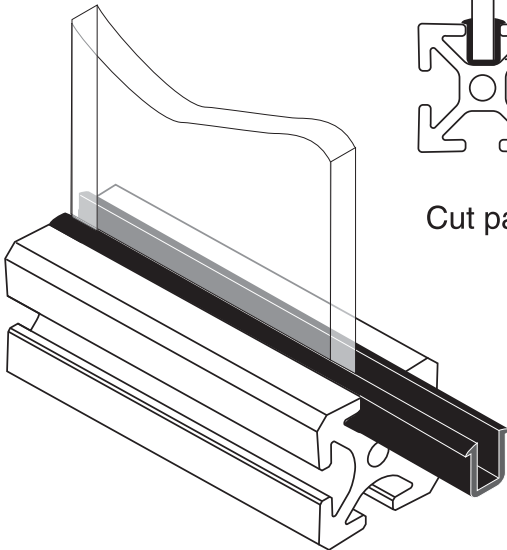

Material:  
Flexible Vinyl  
(Gray)

1/4" SLOTS

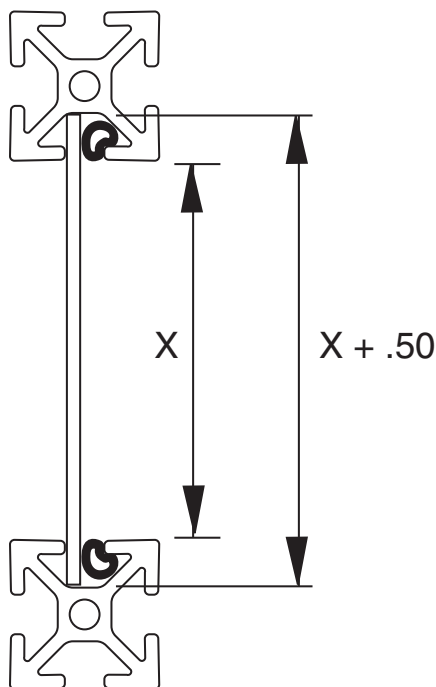
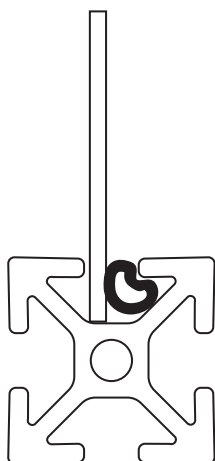
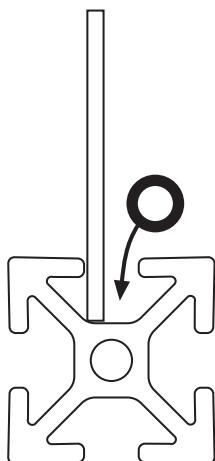

Cut panel to  $X + .50''$

Material	Thickness
16 gage	.060
14 gage	.075
13 gage	.090
12 gage	.105

Material - Rubber (Black)

**1/4" SLOTS**

**11-260**

Clearance for  
1/4-20 x 1.0 SHCS

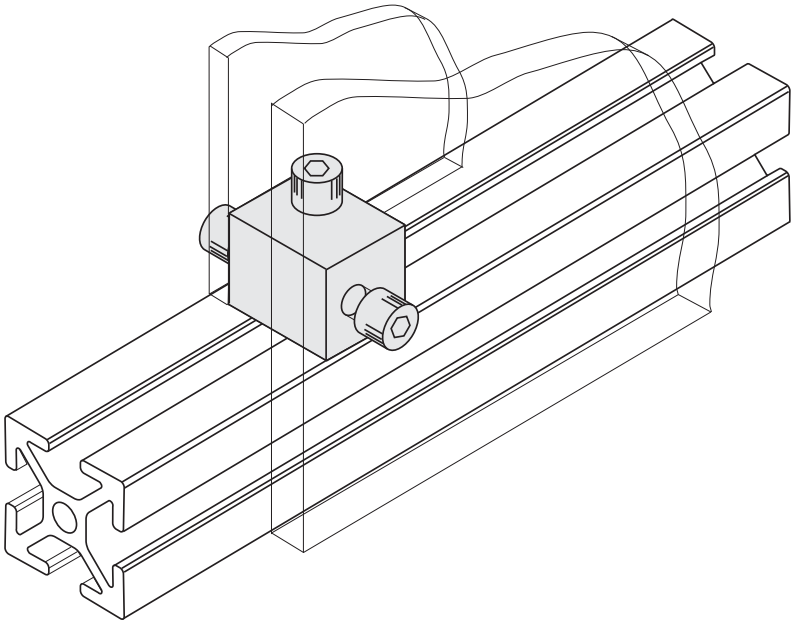
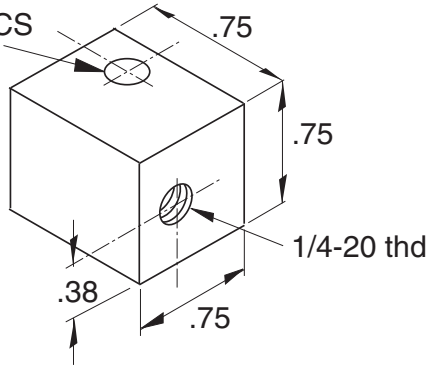

Requires

- (1) 11-224 SHCS
- (1) 11-210 T-nut
- (1) 11-231 BHCS

Material - Aluminum  
Finish - Clear Anodize

1/4" SLOTS

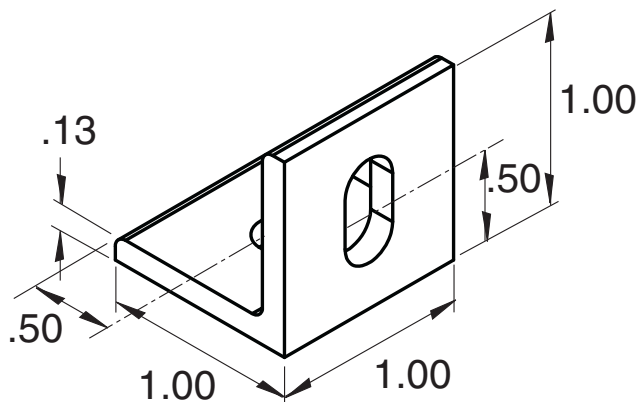
**Recommended  
Hardware**

- (1) 11-230 BHCS
- (1) 11-210 T-nut
- (1) 11-233 BHCS
- (1) 11-240 Washer
- (1) 11-241 Hex nut

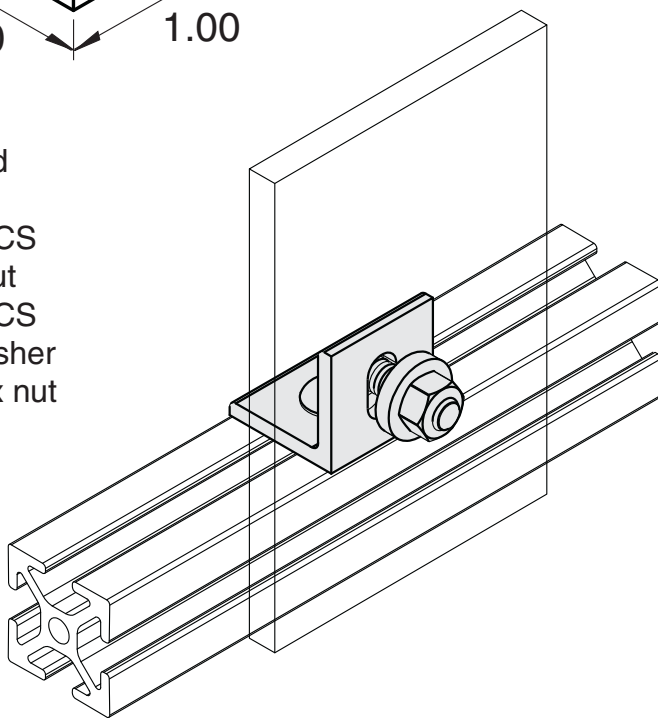
**1/4" SLOTS**

Material - Aluminum  
Finish - Clear Anodized



# Internal Corner Bracket



**11-261**

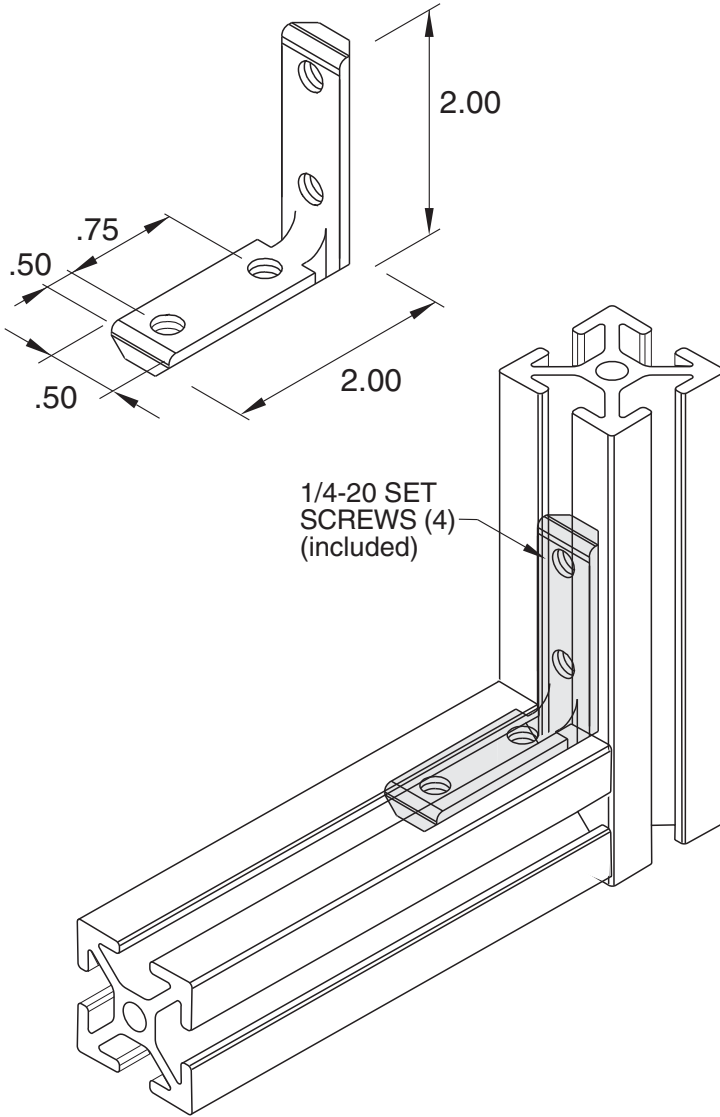

**1/4" SLOTS**

Material - Steel  
Finish - Zinc Plated

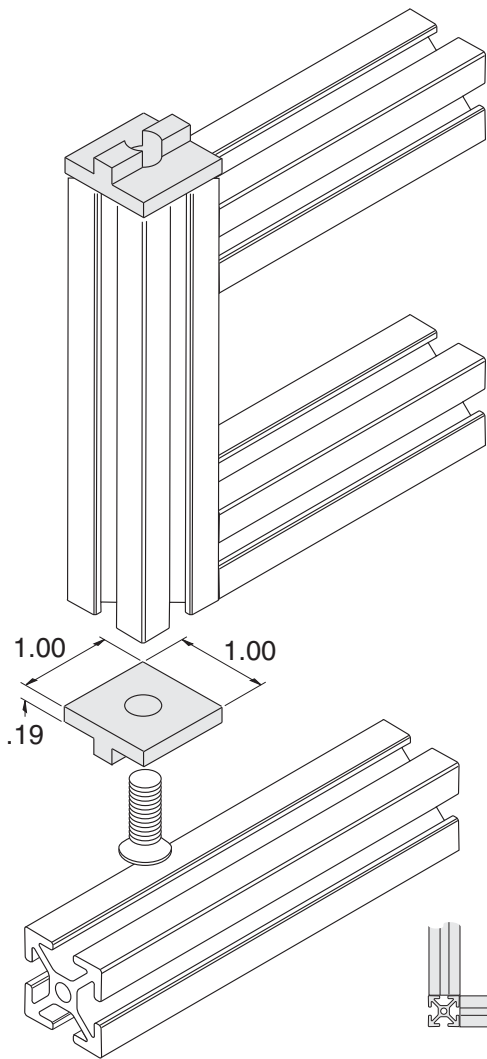

Use on 1" x 1" sq. extrusions  
with 1/4" wide slots

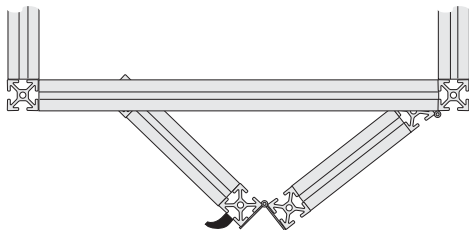

**1/4" SLOTS**

Hardware Included

Pad material is DELRIN

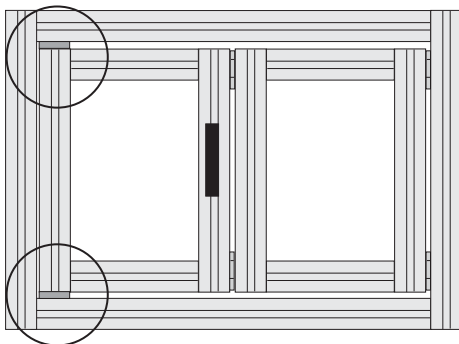

**11-252**

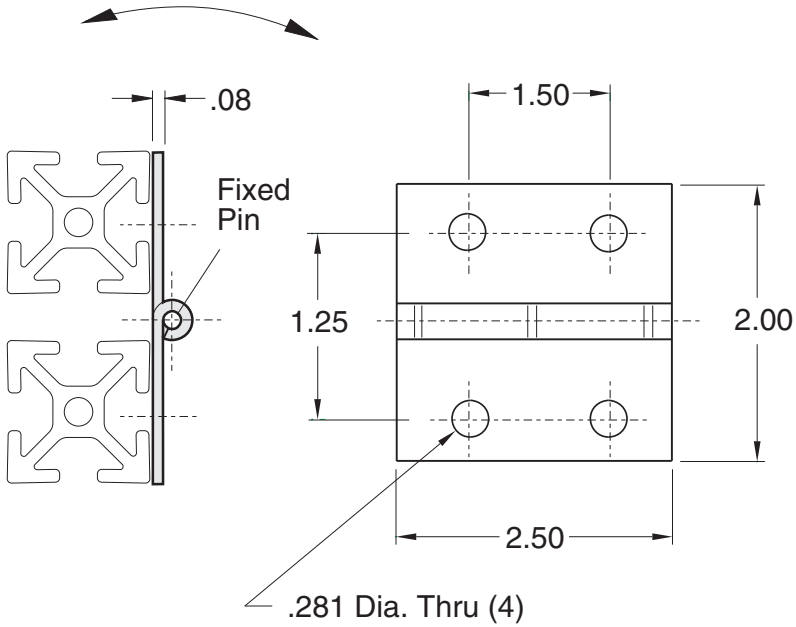

**1/4" SLOTS**

Hardware Included

Material - Aluminum  
Finish - Clear Anodize

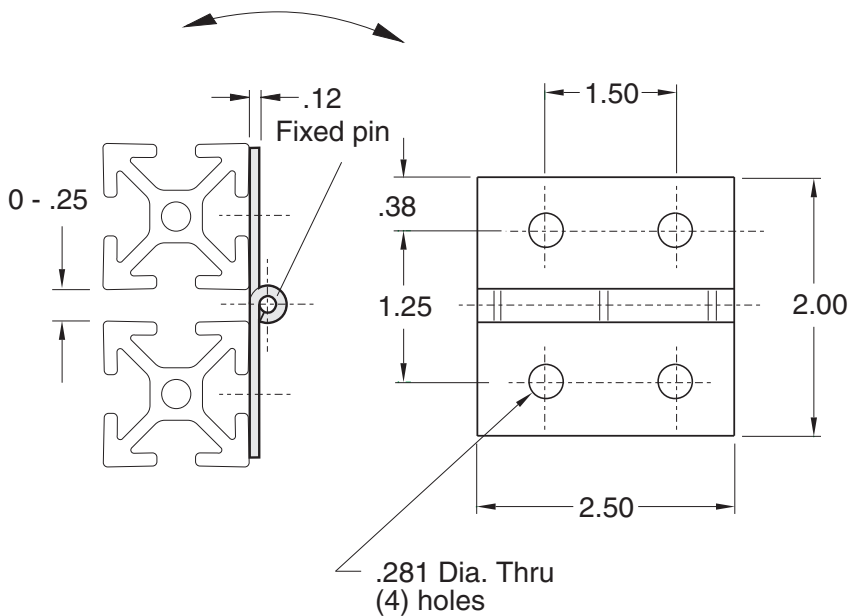

Hardware Included

Material Steel  
Finish Black Powder Coat

**1/4" SLOTS**

11-285

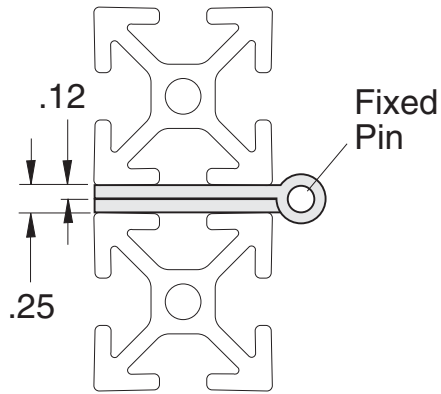
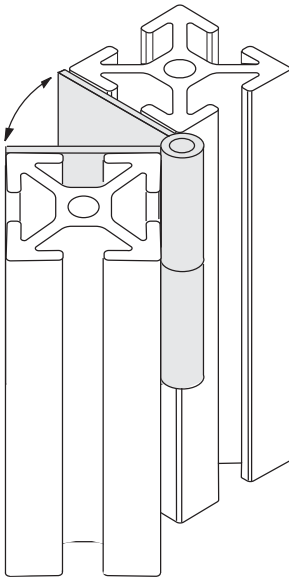
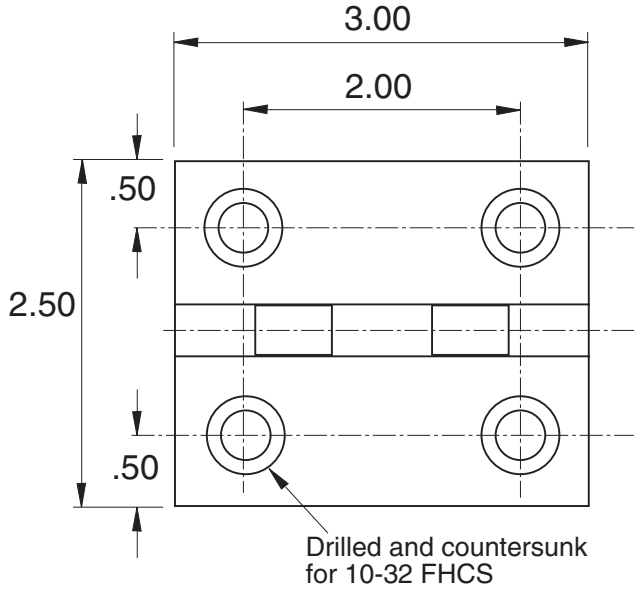

Hardware Included

Material - Steel  
Finish - Black Powder Coat

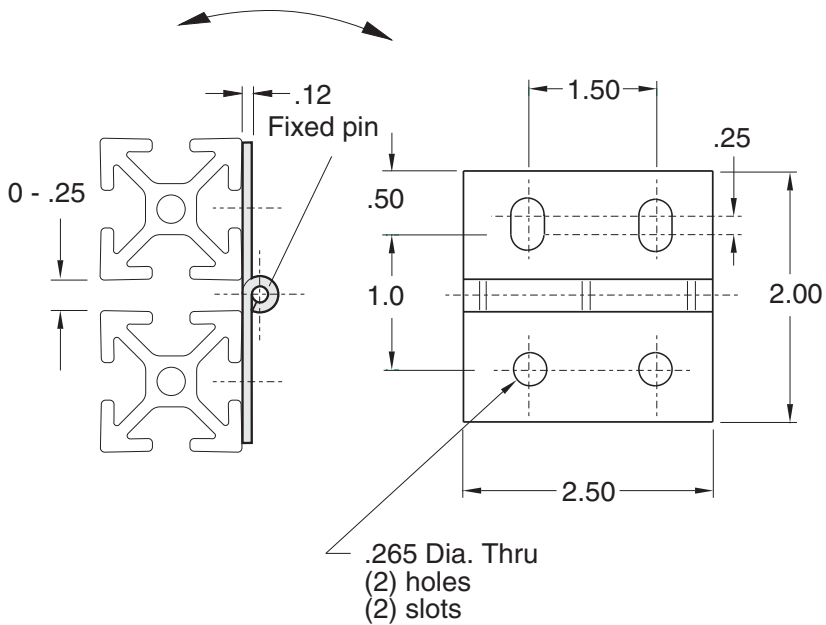

Hardware Included

Material - Steel  
Finish - Black Powder Coat

**1/4" SLOTS**

# Steel Lift-Off Hinge



<b>11-253</b>	<b>Steel Lift-Off Hinge (left hand)</b>
<b>11-254</b>	<b>Steel Lift-Off Hinge (right hand)</b>

Hardware Included

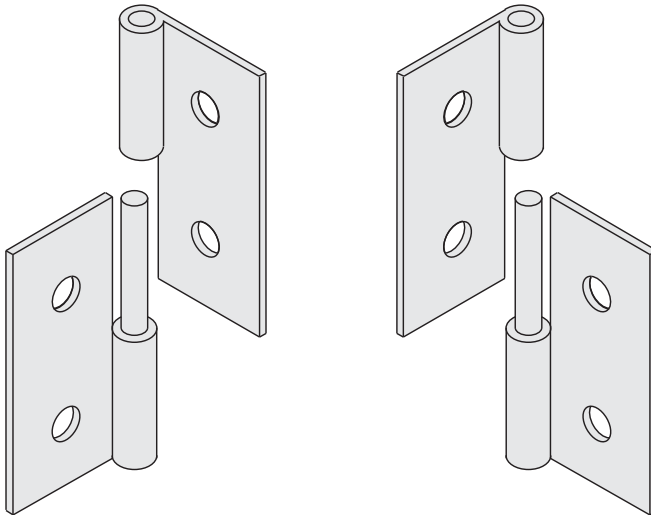
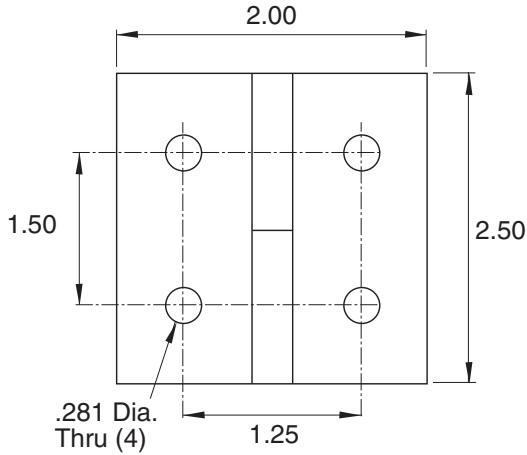

**11-253**

**Left Hand**

**11-254**

**Right Hand**

Material - Steel  
Finish - Zinc Plated

1/4" SLOTS

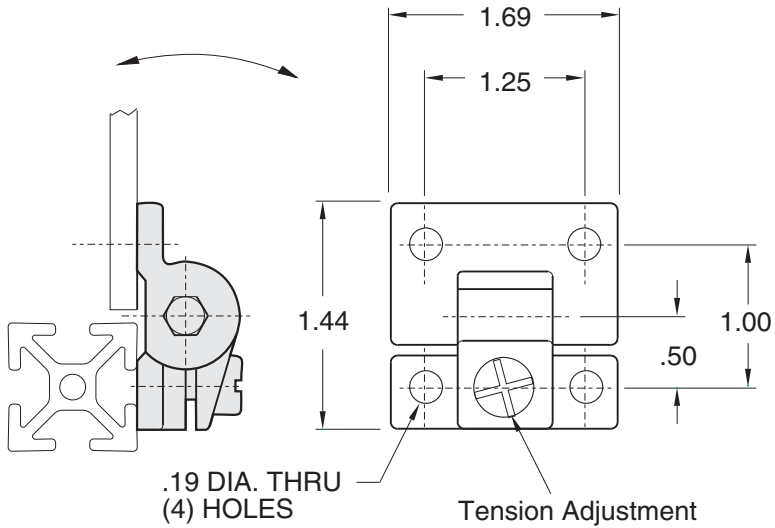

Hardware Included

**1/4" SLOTS**

Material - Plastic



Aluminum Transition Hinge  
(EX-1, EX-6 or EX-9 to EX-11)



11-280

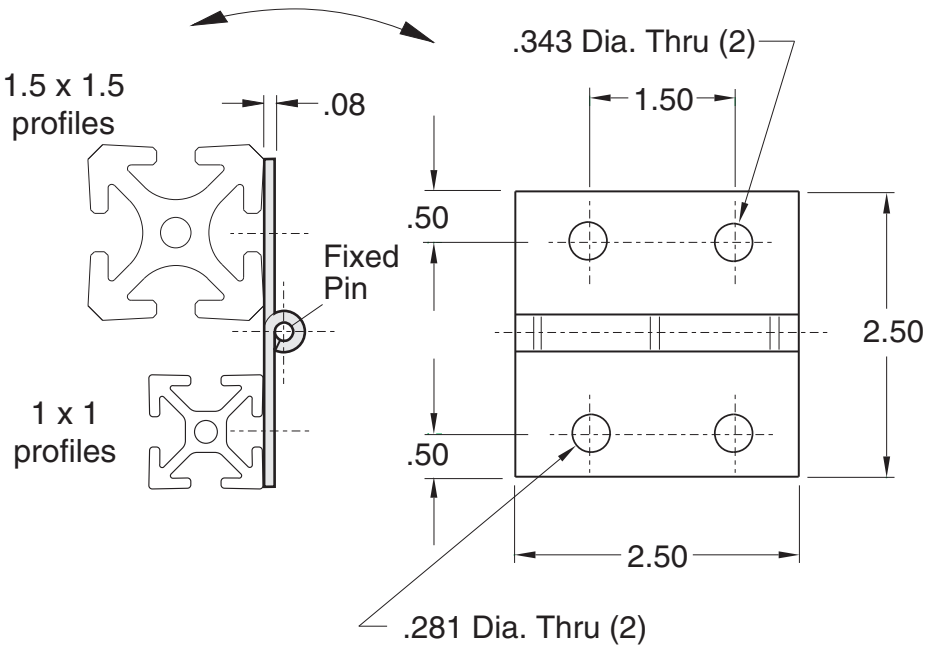

Hardware Included

Material - Aluminum  
Finish - Clear Anodize

1/4" SLOTS

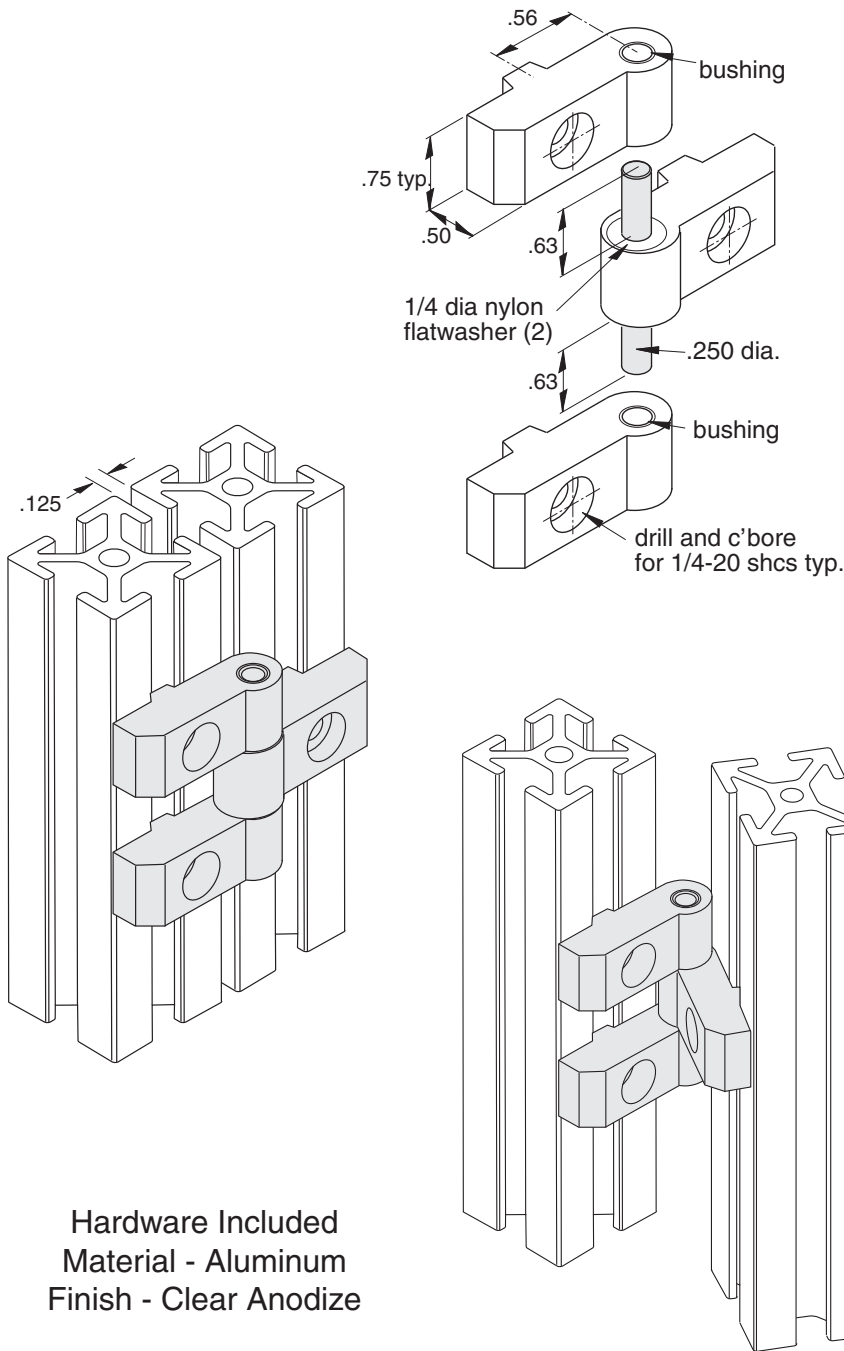

# Left Hand Lift-Off Hinge - 1 / 4" slots



<b>11-402</b>
<b>11-402L</b>
<b>11-402S</b>

One Set w/Long & Short Pin Assemblies

Long Pin Assembly Only

Short Pin Assembly Only

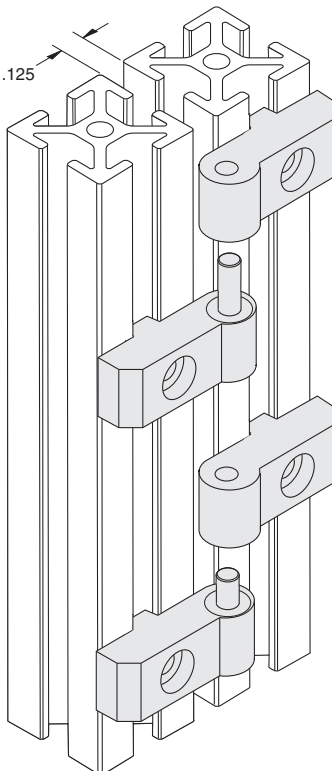
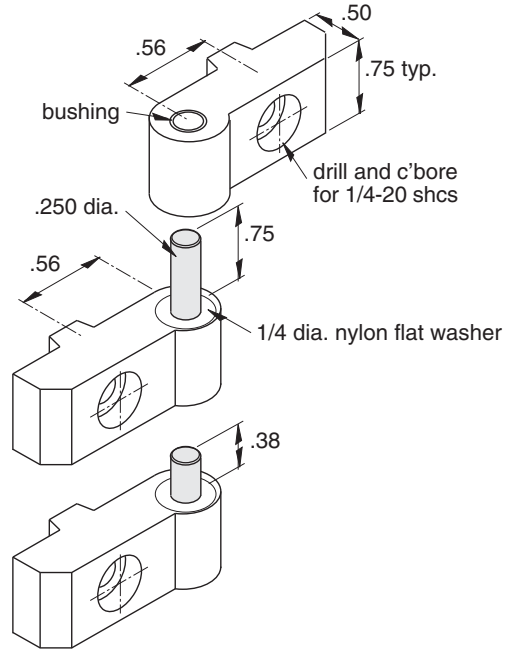

1/4" SLOTS

**11-402L**

Hardware Included  
Material - Aluminum  
Finish - Clear Anodize

**Note:** Use short and long pin assemblies together as shown to ease lift-off and replacement of doors.

**11-402S**

One Set w/Long & Short Pin Assemblies

**11-403**

Long Pin Assembly Only

**11-403L**

Short Pin Assembly Only

**11-403S**

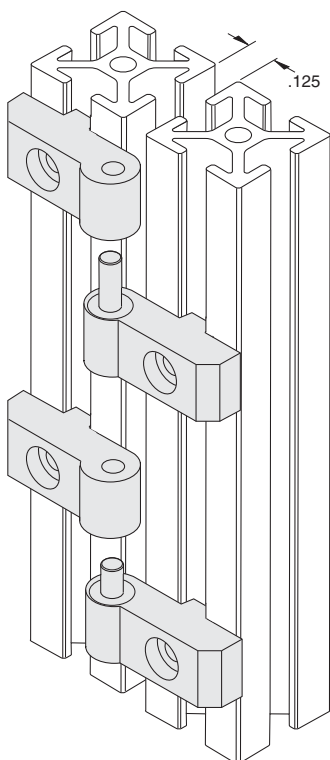
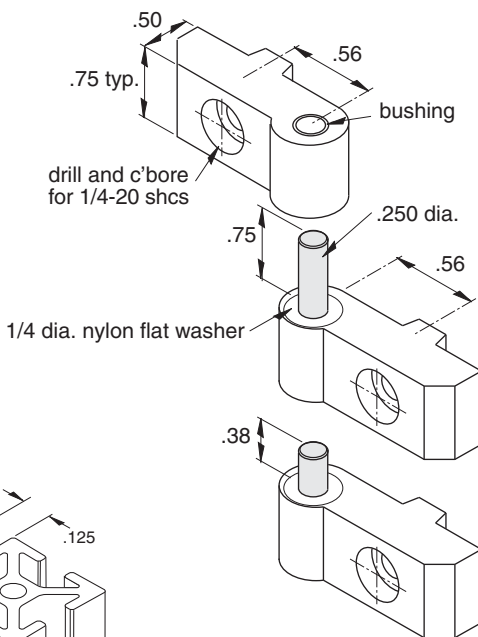

**11-403L**

**11-403S**

**Hardware Included  
Material - Aluminum  
Finish - Clear Anodize**

**Note:** Use short and long pin assemblies together as shown to ease lift-off and replacement of doors.

**1/4" SLOTS**

# Heavy Duty Transition 5/16 - 1/4 slots Hinge Assembly



**EB-140**

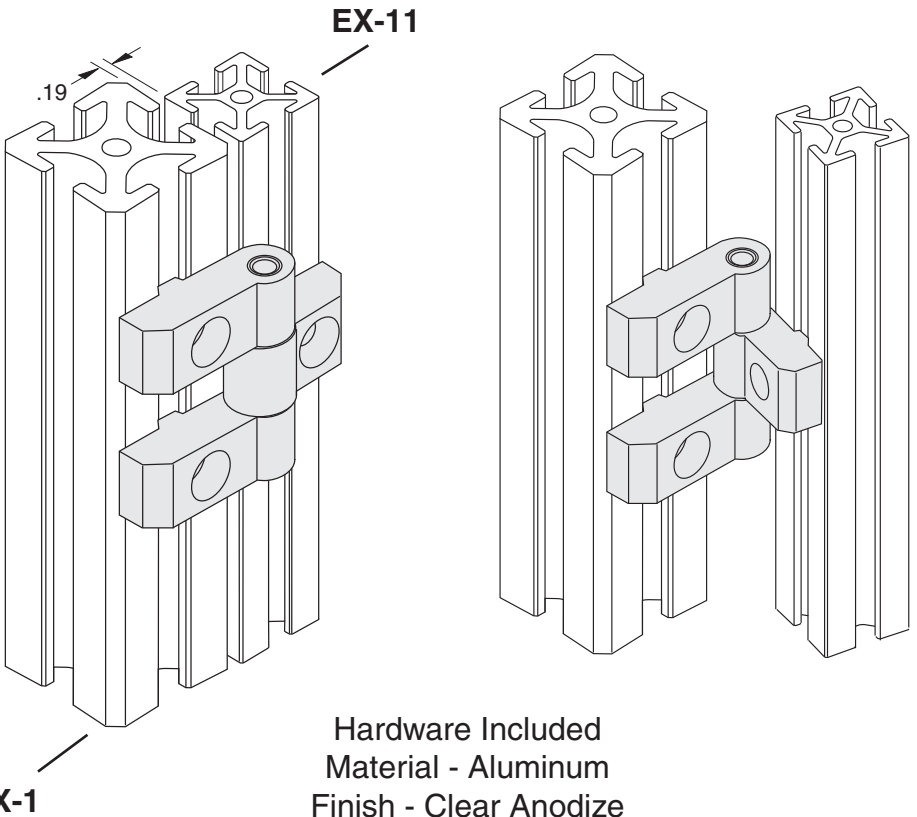
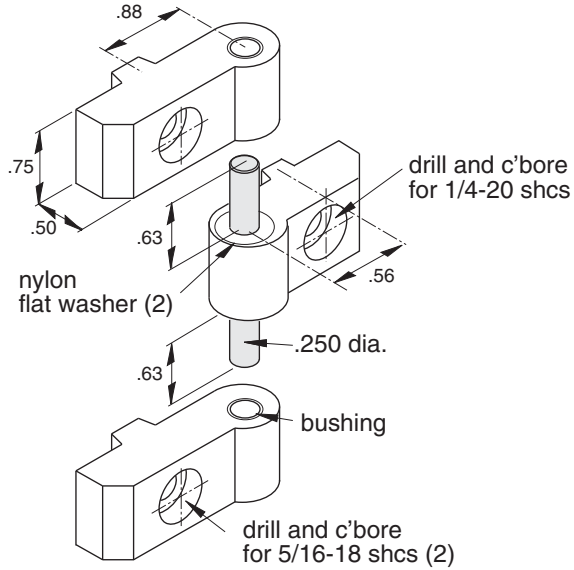

**1/4" SLOTS**

**Hardware Included**  
**Material - Aluminum**  
**Finish - Clear Anodize**

One Set w/Long & Short Pin Assemblies

**EB-142**

Long Pin Assembly Only

**EB-142L**

Short Pin Assembly Only

**EB-142S**

**Hardware Included**  
Material - Aluminum  
Finish - Clear Anodize

**Note:** Use short and long pin assemblies together as shown to ease lift-off and replacement of doors.

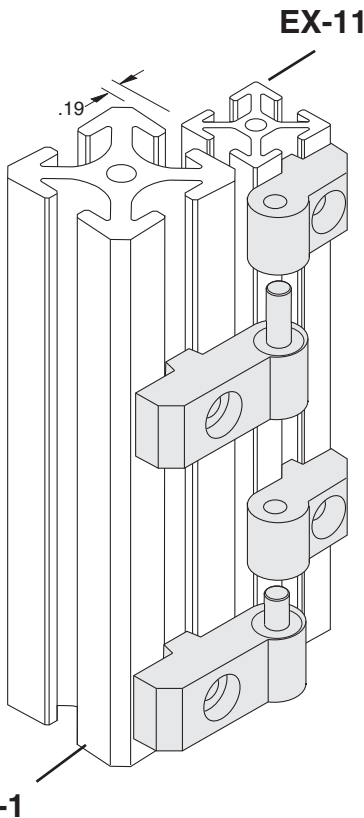
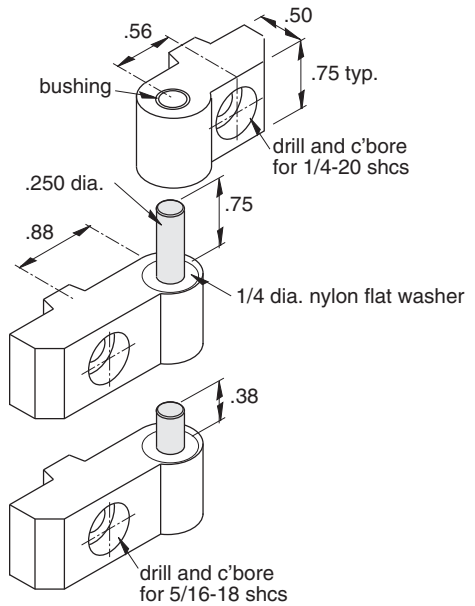

**EB-142L**

**EB-142S**

**1/4" SLOTS**

**Right Hand Transition  
Lift-Off Hinge 5/16 - 1/4 slots**



<b>EB-143</b>	One Set w/Long & Short Pin Assemblies
<b>EB-143L</b>	Long Pin Assembly Only
<b>EB-143S</b>	Short Pin Assembly Only

Hardware Included  
Material - Aluminum  
Finish - Clear Anodize

**Note:** Use short and long pin assemblies together as shown to ease lift-off and replacement of doors.

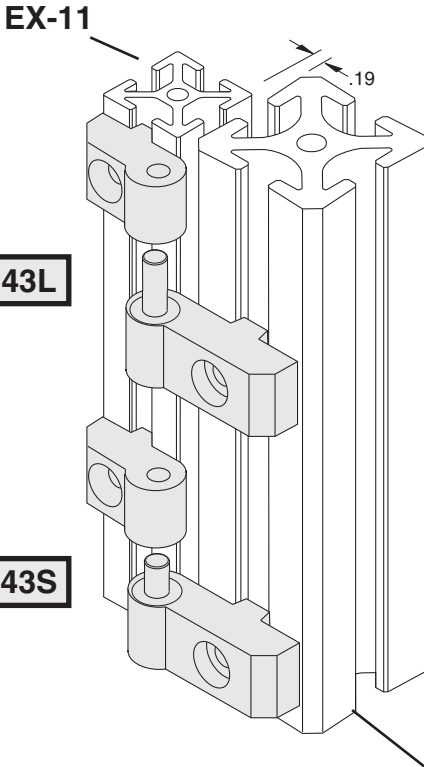
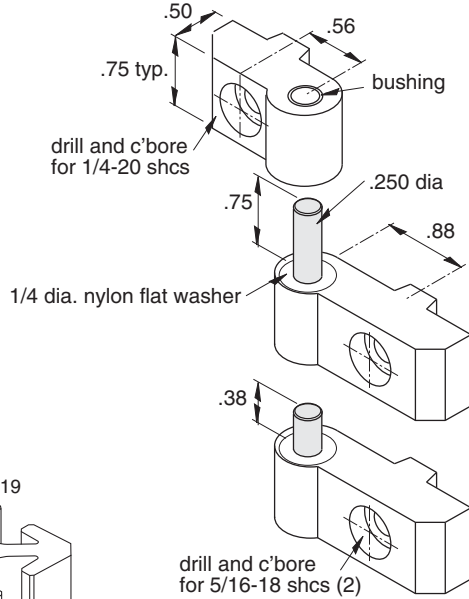

1/4" SLOTS

EX-1

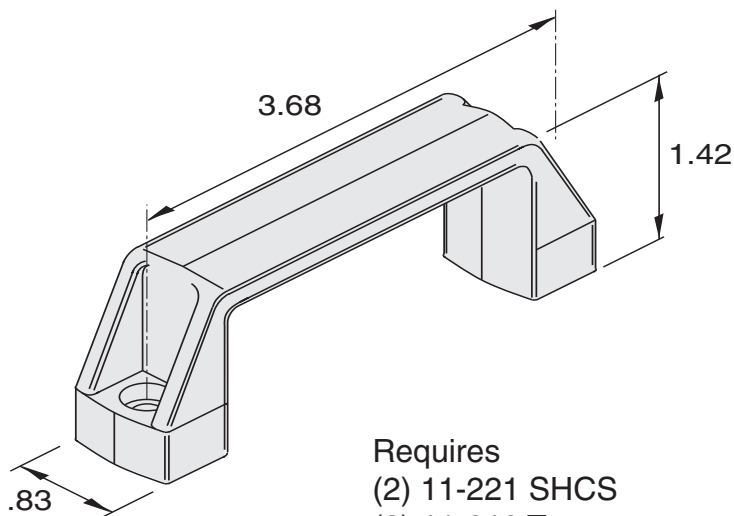

Requires  
(2) 11-221 SHCS  
(2) 11-210 T-nut

**1/4" SLOTS**

Material - Plastic  
Color- Black



# Mechanical Latch 1/4" slots



**11-282**

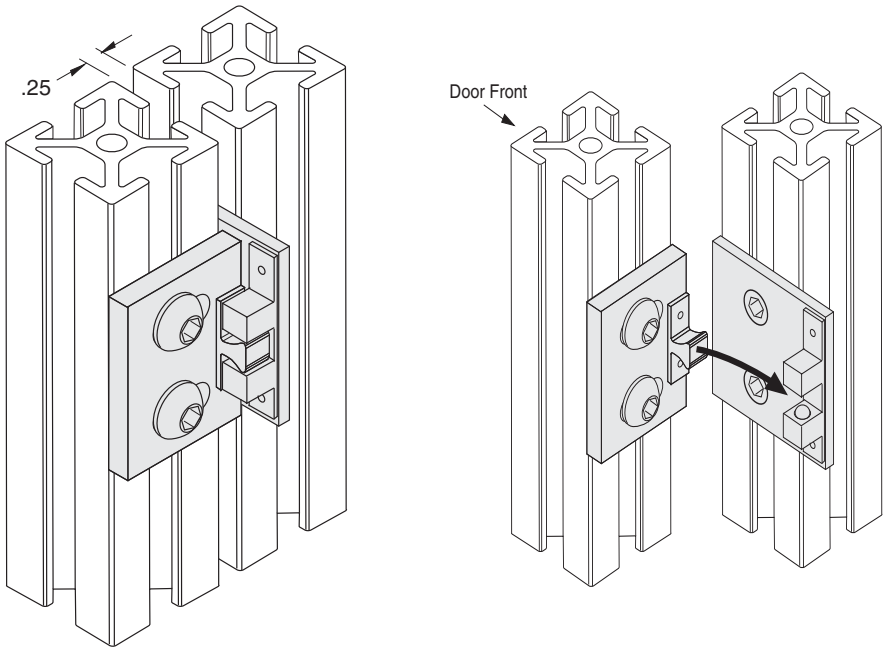
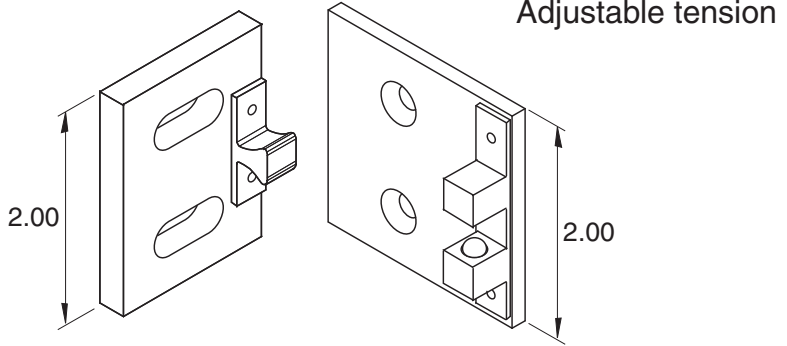

**1/4" SLOTS**

Hardware Included  
Material Mounting Plates: Aluminum, Clear Anodize  
Latch: Zinc Plated Brass

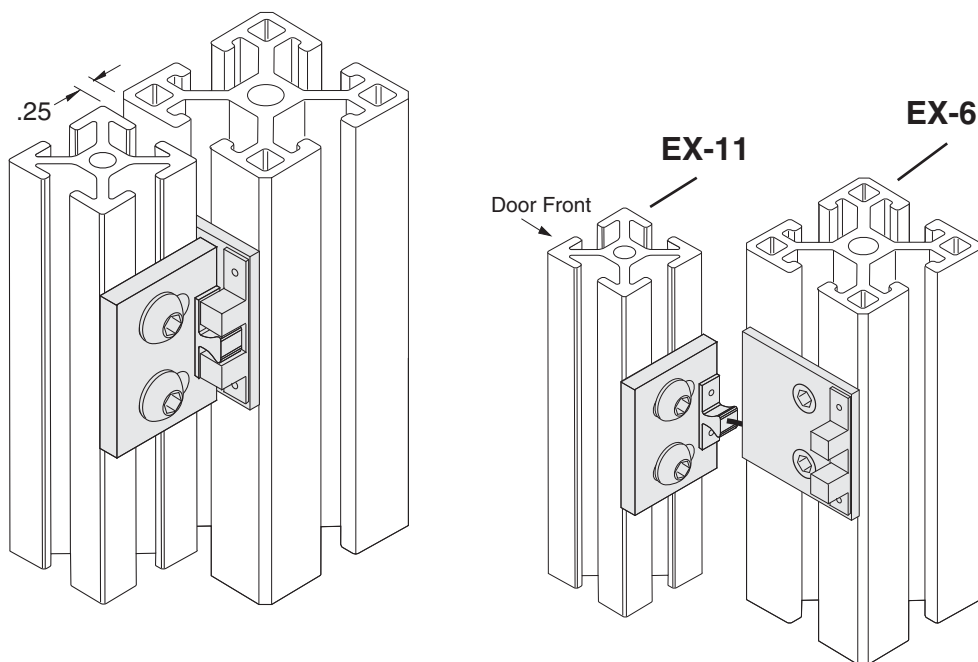
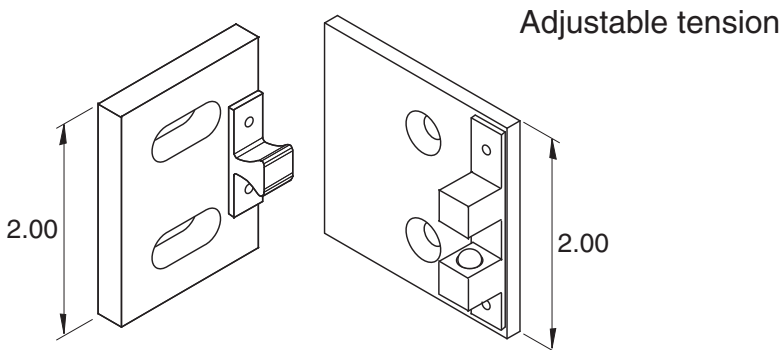

Hardware Included  
Material Mounting Plates: Aluminum, Clear Anodize  
Latch: Zinc Plated Brass

# Single Door Mechanical Latch



**11-264**

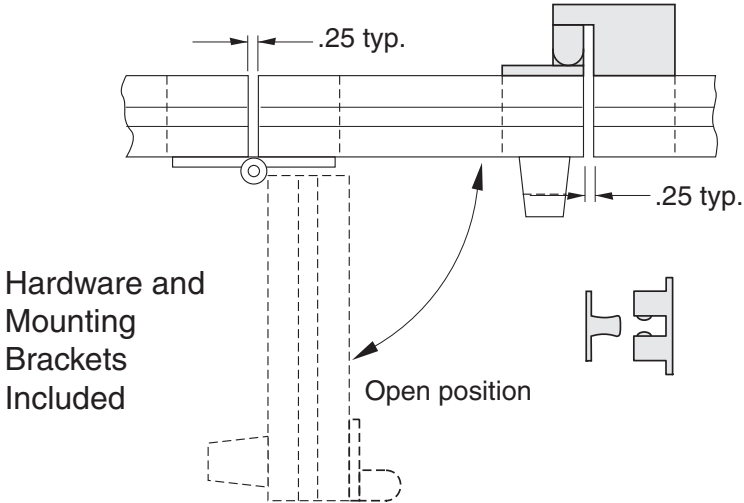

Catch Material - Zinc Plated Brass  
Base Material - Aluminum

# Double Door Mechanical Latch

**11-265**

1/4" SLOTS

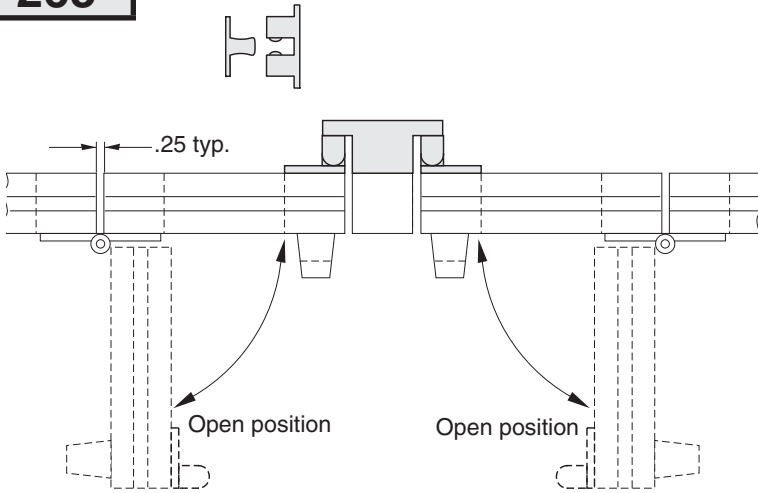

Hardware and Mounting Brackets Included  
Catch Material - Zinc Plated Brass  
Base Material - Aluminum

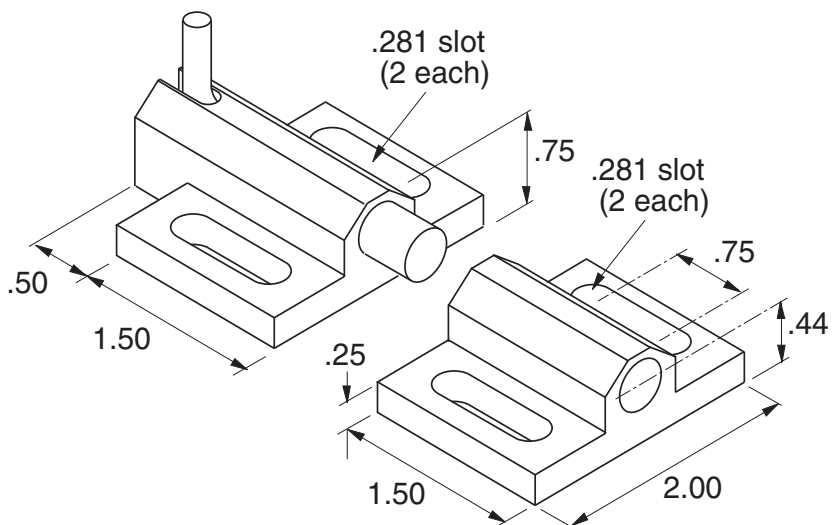

Hardware Included

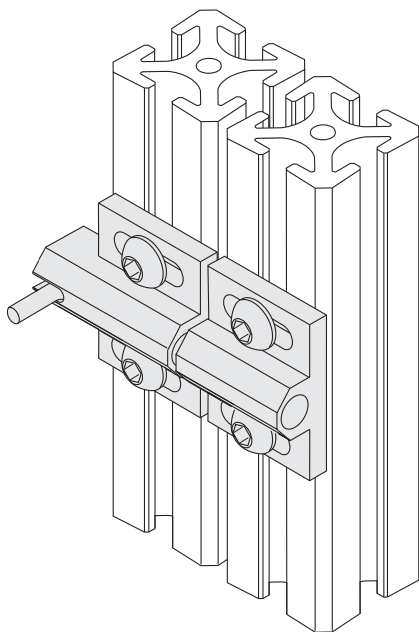

Material:  
 Mounting Plates:  
 Aluminum, Clear Anodize  
 Dead Bolt: Zinc Plated Steel

**1/4" SLOTS**

# Deadbolt Latch



**11-273**

**.281 dia. Bolt**

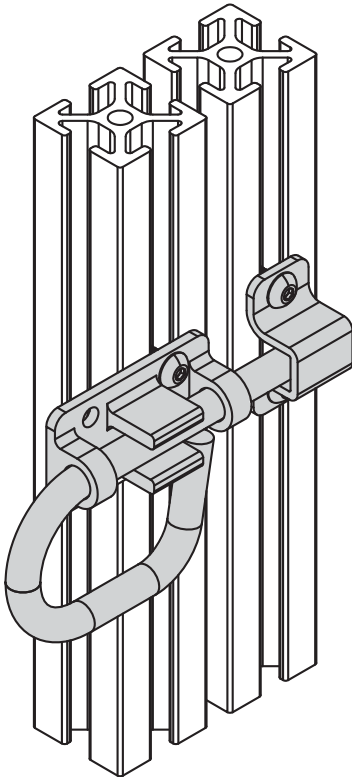
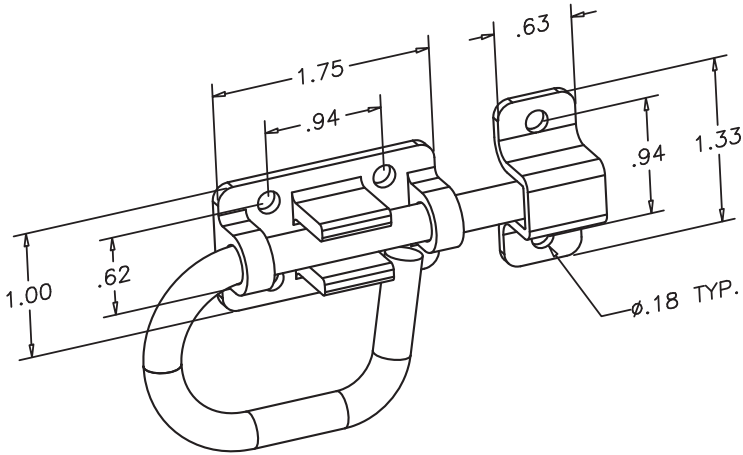

**1/4" SLOTS**

Hardware Included

Use with 1/4" slot extrusions

Material - Zinc Plated Steel

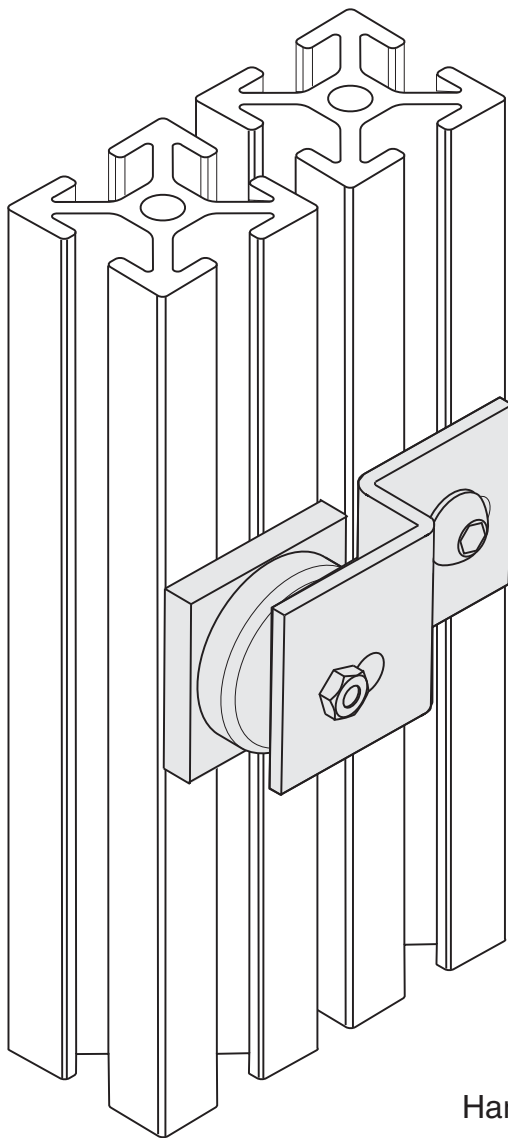

Hardware Included

Material - Steel  
Finish - Zinc Plated

**1/4" SLOTS**

# Slider Assembly



<b>11-98</b>
<b>11-99</b>

Slider Assembly (as shown)  
Slider Assembly  
(less clamp handle for sliding only)

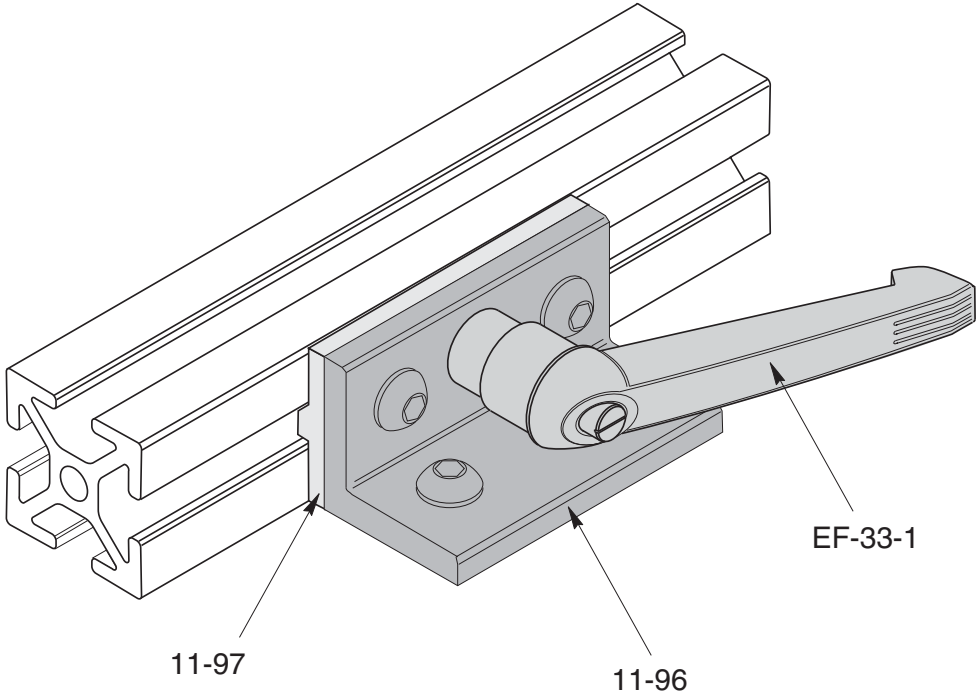

1/4" SLOTS

Bearing Material is DELRIN (White)

Hardware Included with 11-98 and 11-99

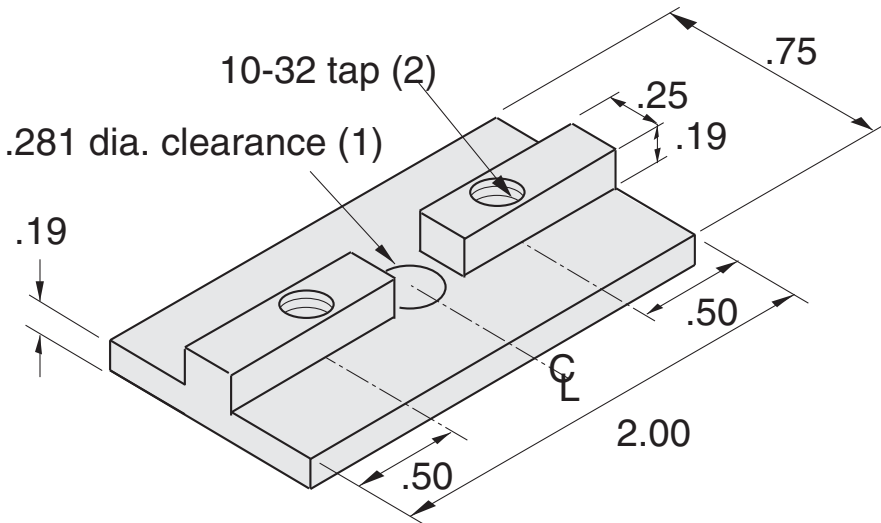

Load Capacity = 50lbs

Bearing Material is DELRIN (White)

**1/4" SLOTS**



**11-96**

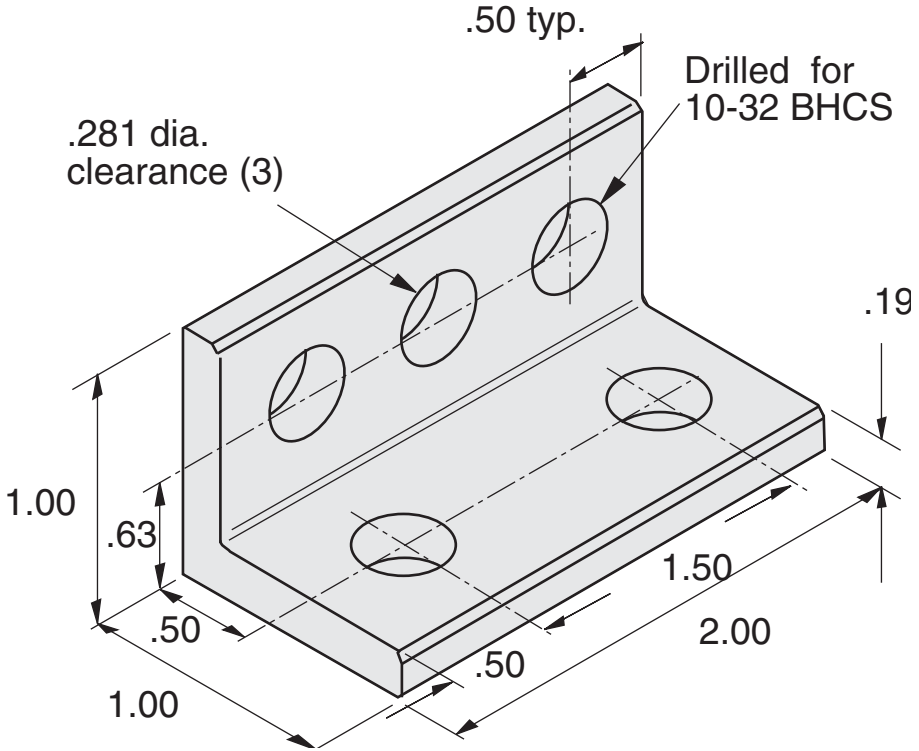

**1/4" SLOTS**

- Recommended Hardware
- (2) 11-231 BHCS
  - (2) 11-210 T-nut
  - (2) 10-32 x 5/8 BHCS

Note: see part no. 11-98 for example

Material - Aluminum  
Finish - Clear Anodize

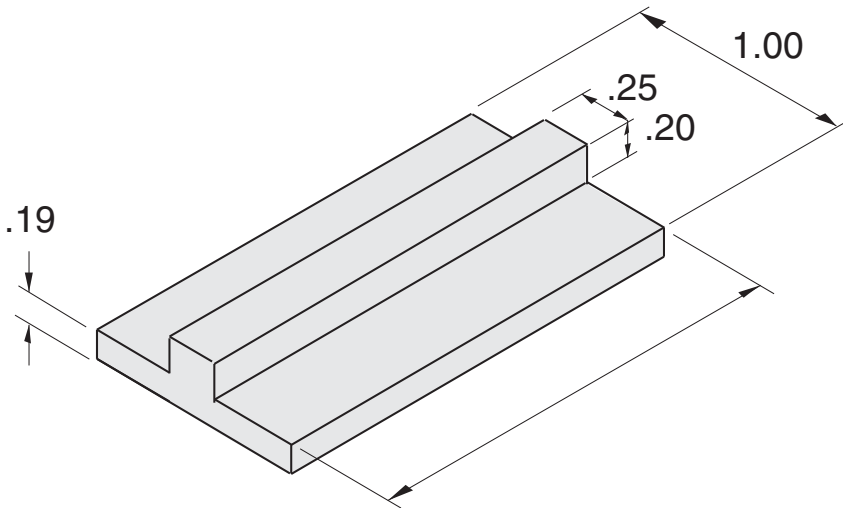

**1/4" SLOTS**

Stock Length 60"

Material - UHMW (White)

# Offset Bearing Block (Plastic)



**11-290**

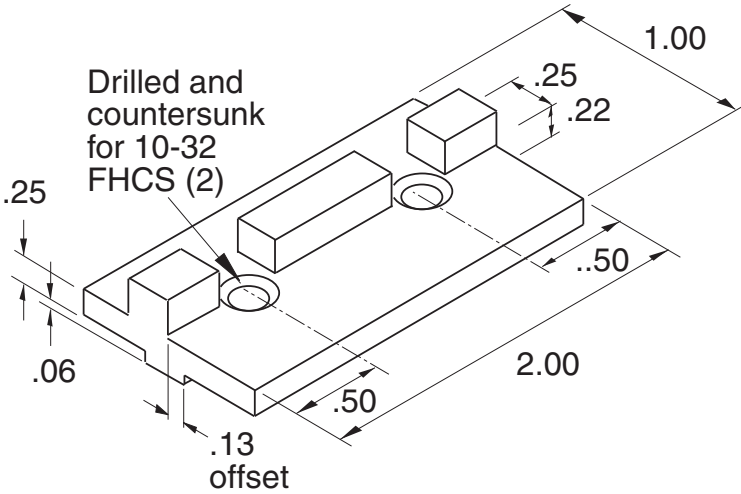

.25 Between Doors with (2) 11-290  
.125 Between Doors with (1) 11-290 and (1) 11-291

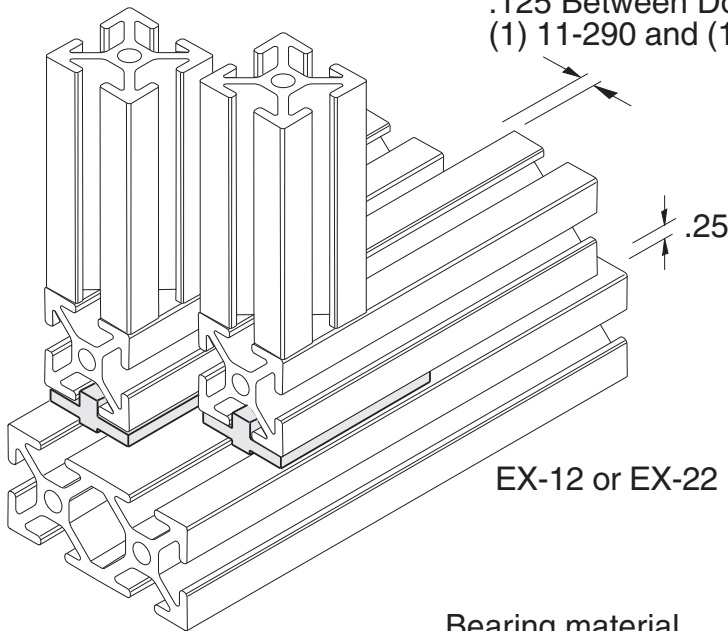

1/4" SLOTS

Bearing material is DELRIN (White)

Hardware Included

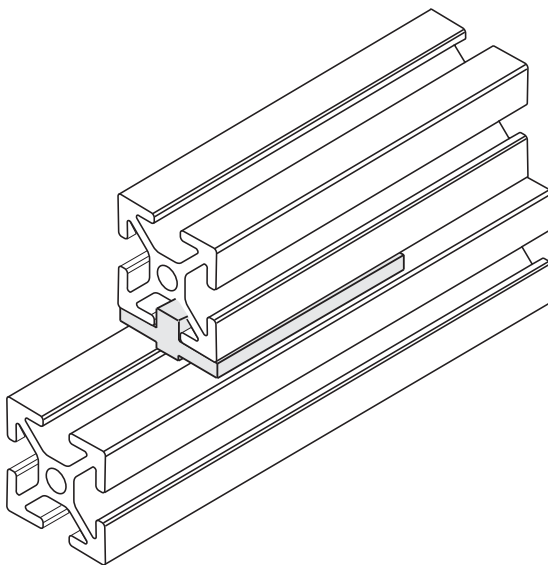
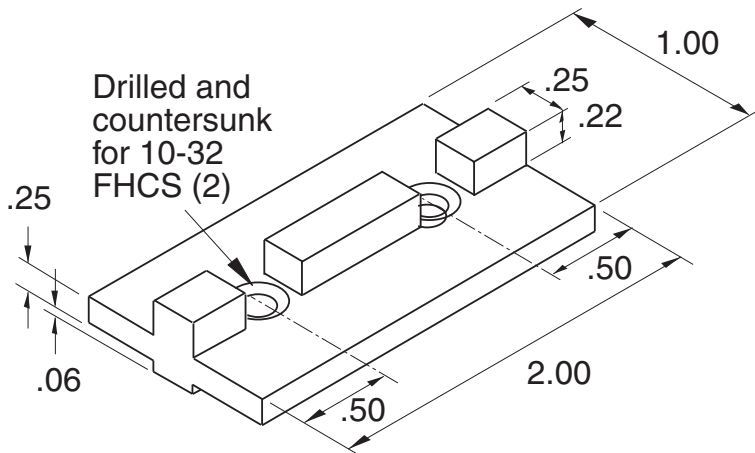

**1/4" SLOTS**

Bearing material is DELRIN (White)

Hardware Included

# Offset Bearing Block (Plastic)



**11-293**

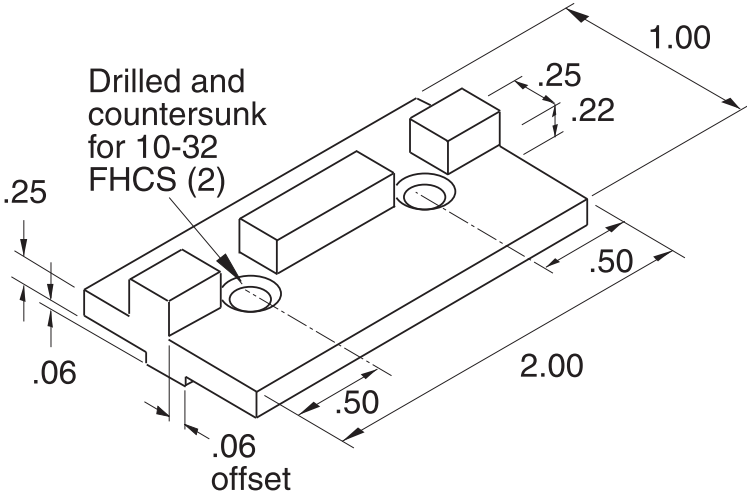

.13 Between Doors with (2) 11-293  
.06 Between Doors with (1) 11-293 and (1) 11-291

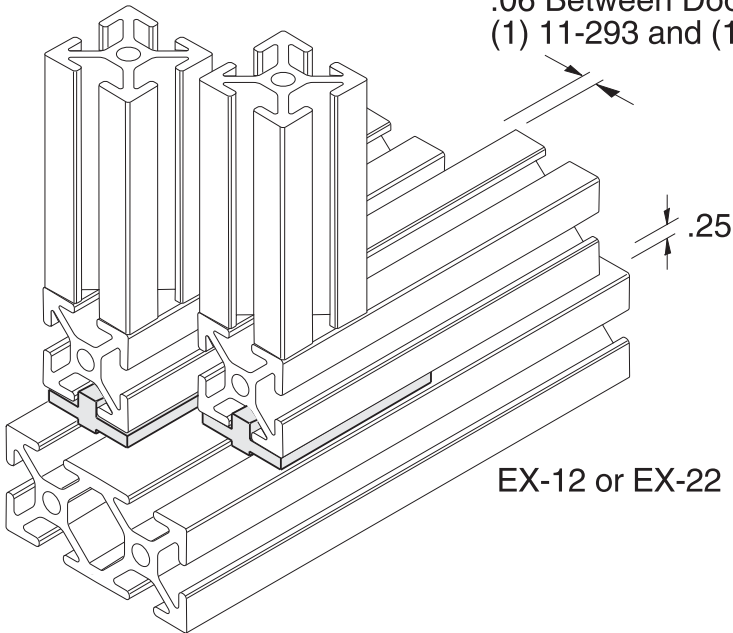

Hardware Included

Bearing material is DELRIN (White)

1/4" SLOTS

**Door Roller Block - 1/4" Slot (lift out)**

1/16" offset	<b>11-288</b>
on center	<b>11-289</b>

**Door Clearance Between Sliders**

- = .13" using (4) 11-288 and (4) 11-293
- = .06" using (2) 11-288 with (2) 11-293  
and (2) 11-289 with (2) 11-291

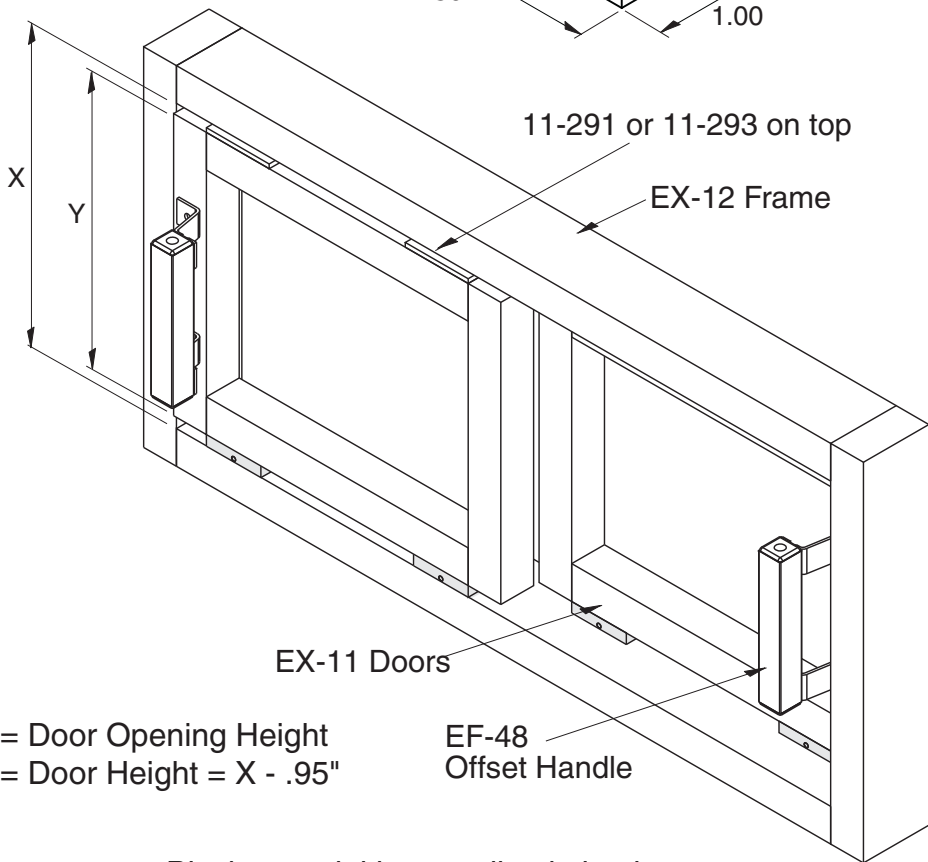
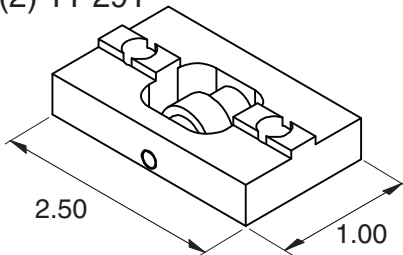

X = Door Opening Height  
Y = Door Height = X - .95"

EF-48  
Offset Handle

Block material is anodized aluminum  
Roller is DELRIN

Hardware Included

**1/4" SLOTS**

11-266

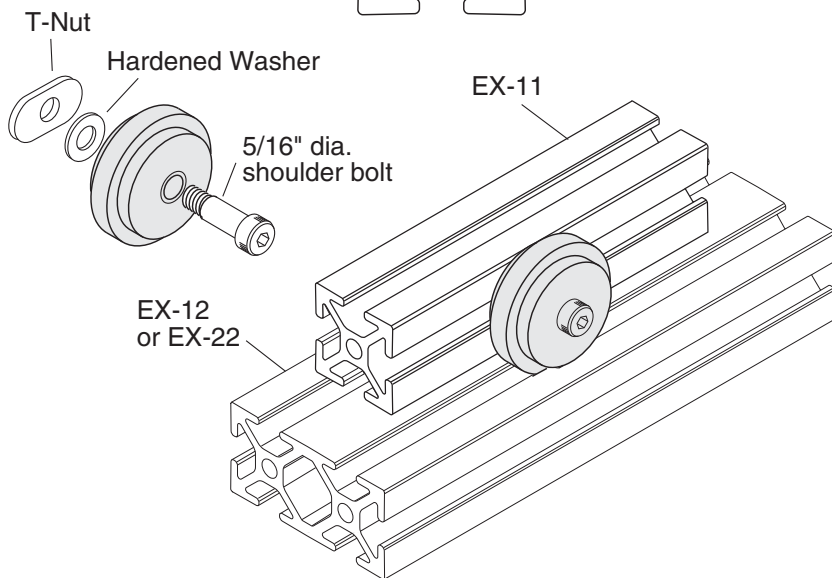
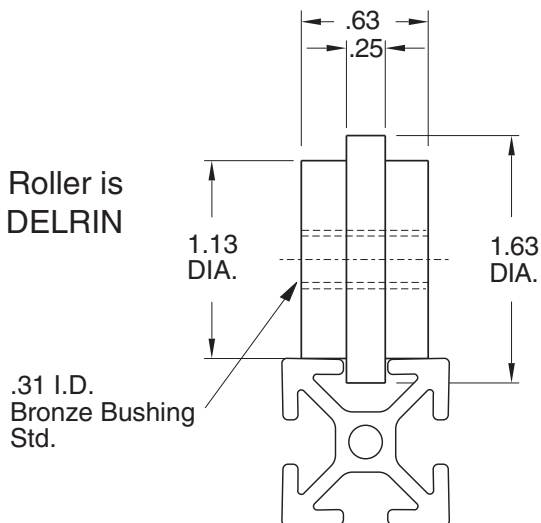

1/4" SLOTS

Hardware Included

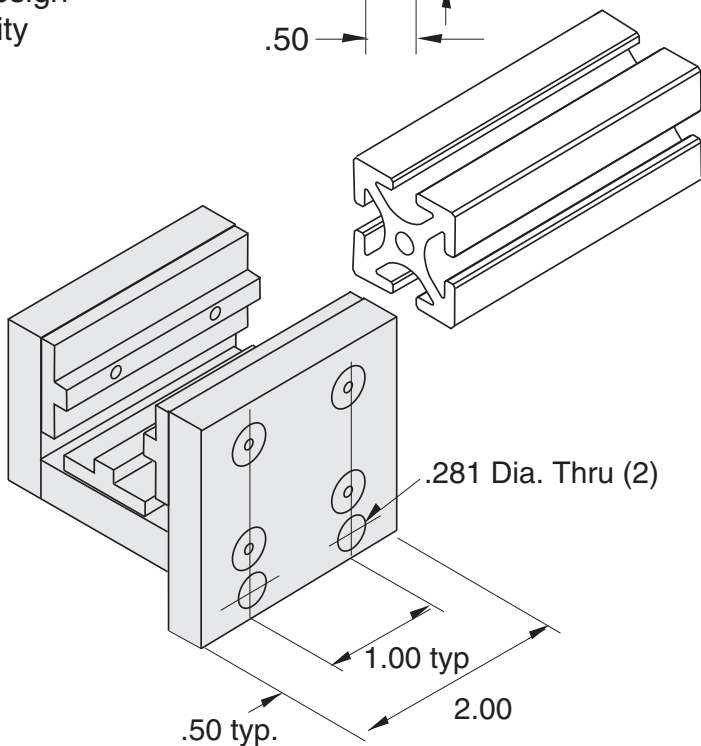
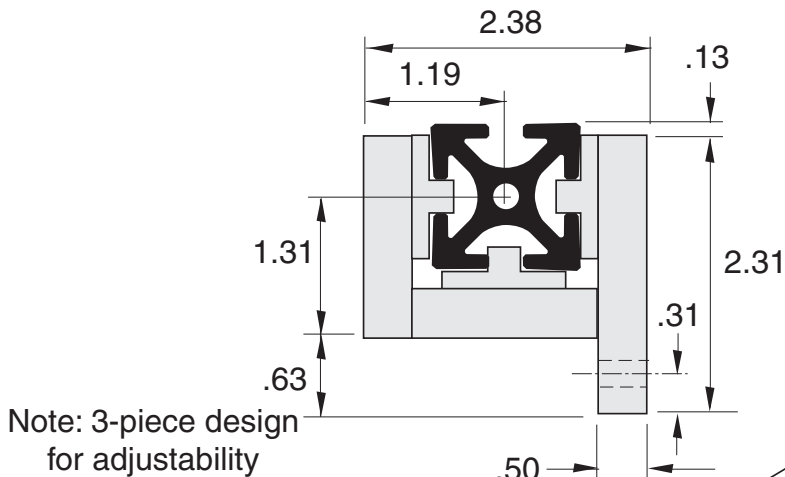

Recommended Hardware  
 (2) 11-233 BHCS  
 (2) 11-205 T-nut

Bearing Material - DELRIN  
 Plate Material - Aluminum  
 Finish - Clear Anodize



# Single Mount Linear Bearing with Locking Handle



**11-91LH**

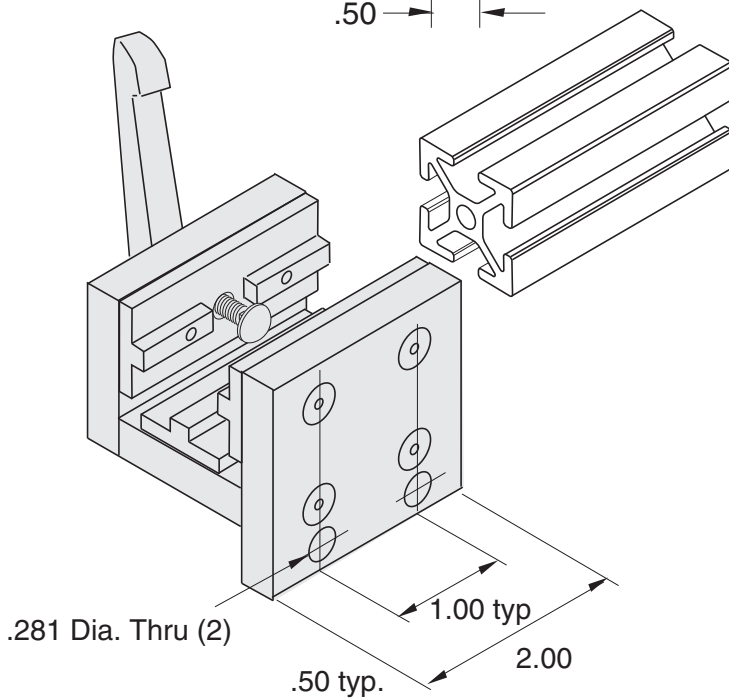
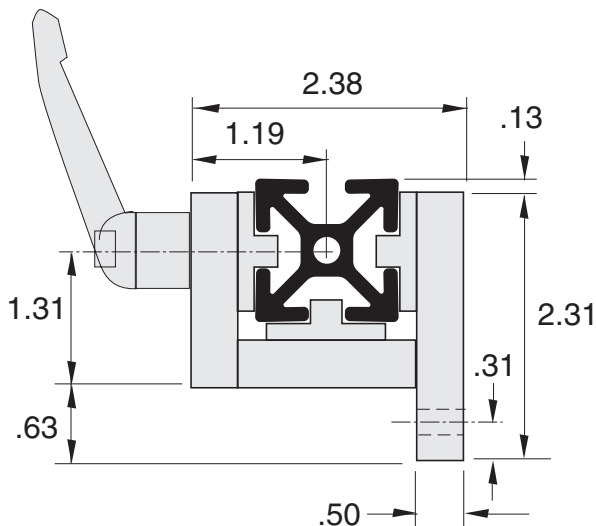

**1/4" SLOTS**

Recommended  
Hardware  
(2) 11-233 BHCS  
(2) 11-205 T-nut

Bearing Material - DELRIN  
Plate Material - Aluminum  
Finish - Clear Anodize

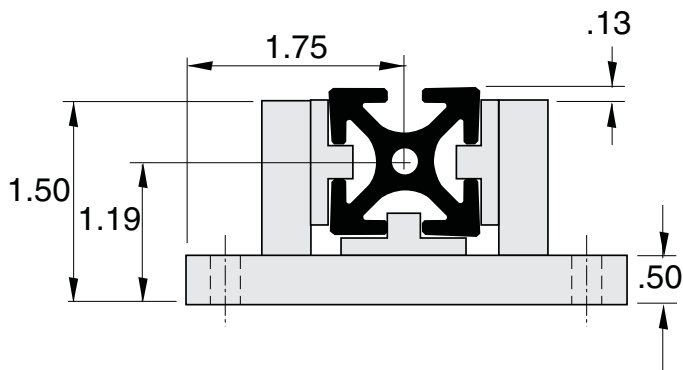

Note: 3-piece design  
for adjustability

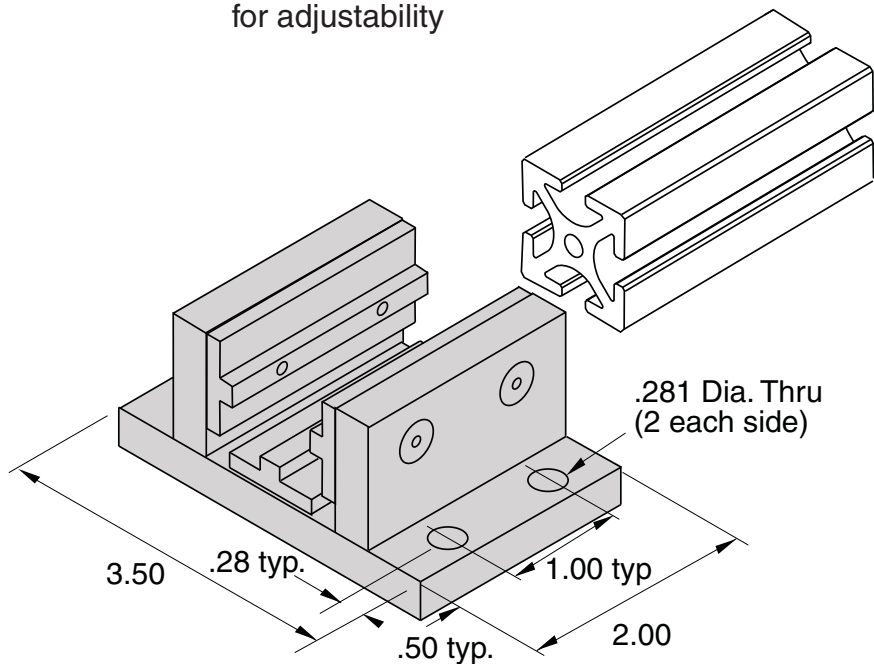

**1/4" SLOTS**

Recommended  
Hardware  
(4) 11-233 BHCS  
(4) 11-205 T-nut

Bearing Material - DELRIN  
Plate Material - Aluminum  
Finish - Clear Anodize

# Single Mount Linear Bearing with Locking Handle



**11-93LH**

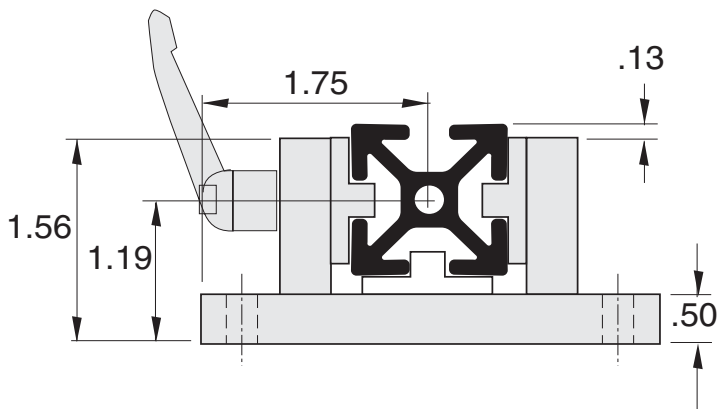

Note: 3-piece  
design for adjust-  
ability

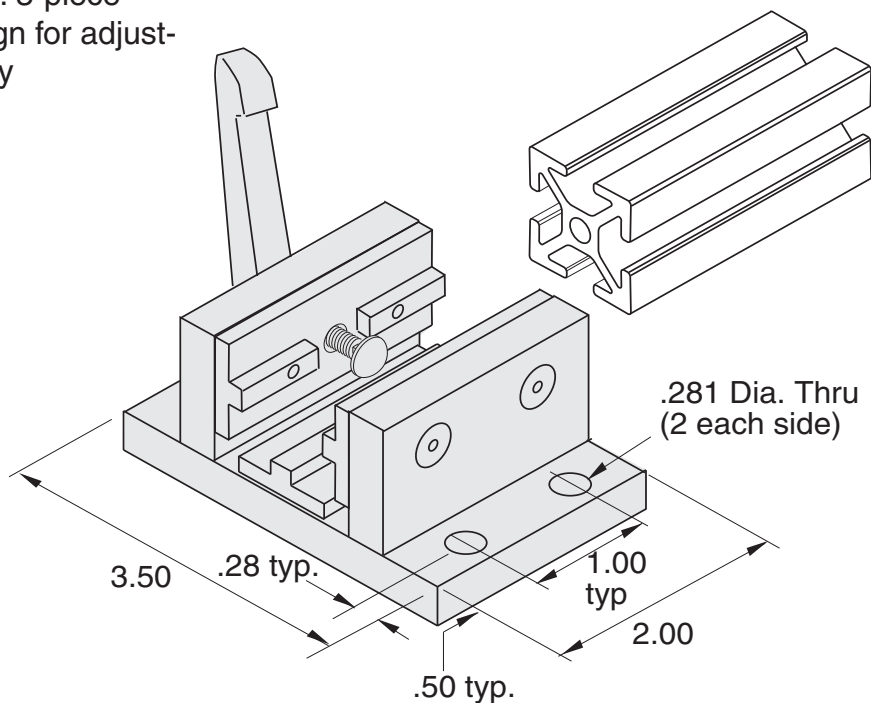

**1/4" SLOTS**

Recommended  
Hardware  
(4) 11-233 BHCS  
(4) 11-205 T-nut

Bearing Material - DELRIN  
Plate Material - Aluminum  
Finish - Clear Anodize

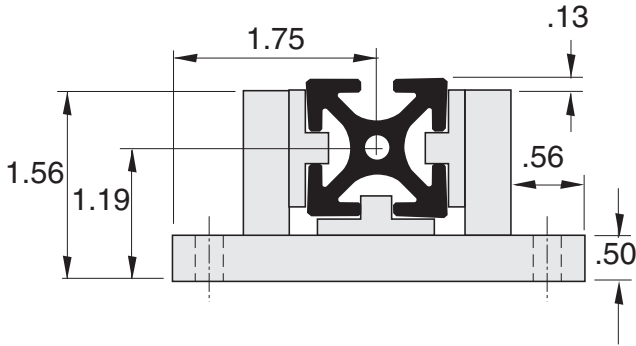

Note: 3-piece design  
for adjustability

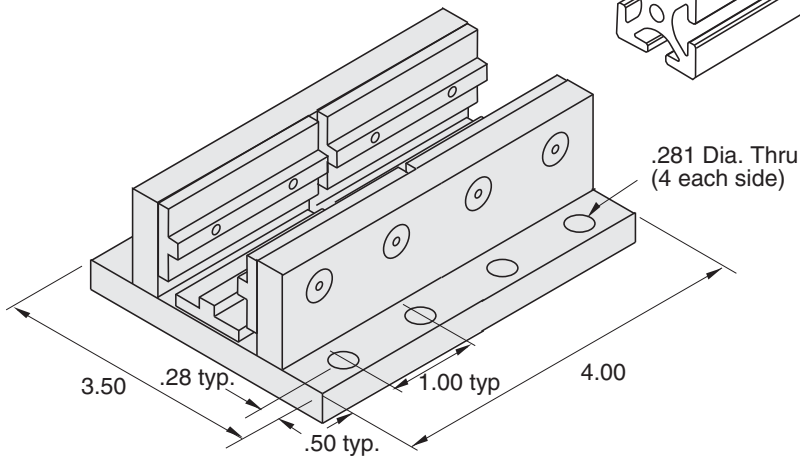
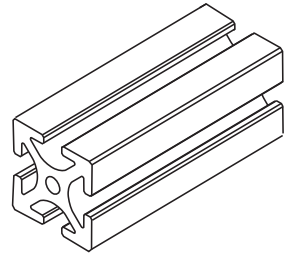

**1/4" SLOTS**

Recommended  
Hardware  
(8) 11-233 BHCS  
(8) 11-205 T-nut

Bearing Material - DELRIN  
Plate Material - Aluminum  
Finish - Clear Anodize

# Double Mount Linear Bearing with Locking Handle



**11-92LH**

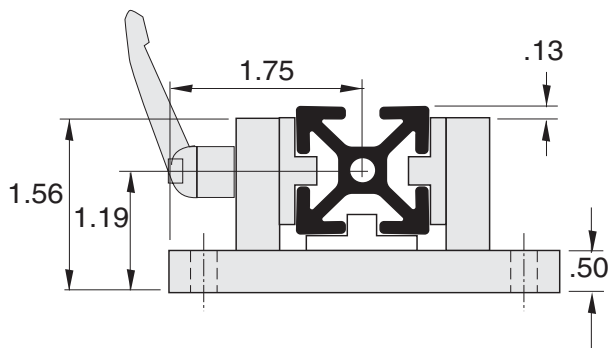

Note: 3-piece design for adjustability

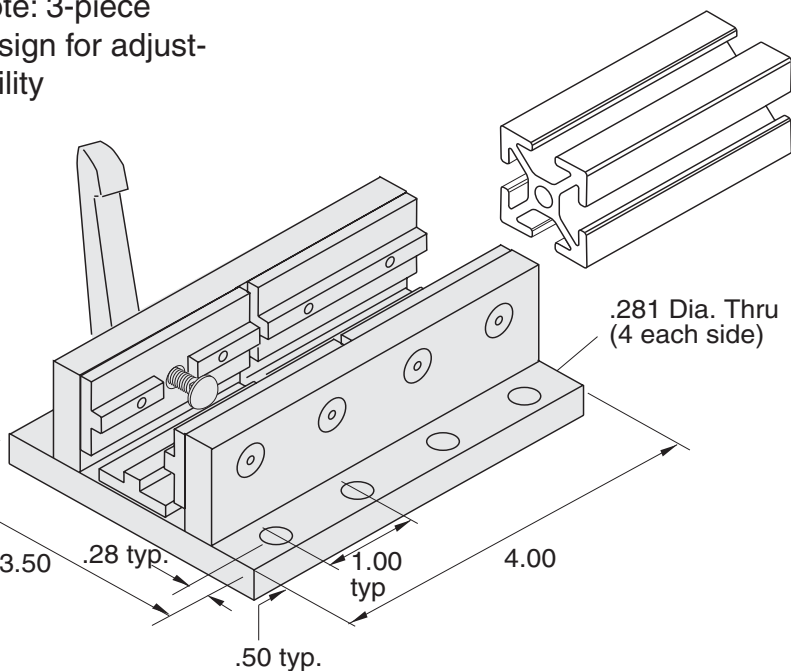

**1/4" SLOTS**

Recommended Hardware  
 (8) 11-233 BHCS  
 (8) 11-205 T-nut

Bearing Material - DELRIN  
 Plate Material - Aluminum  
 Finish - Clear Anodize

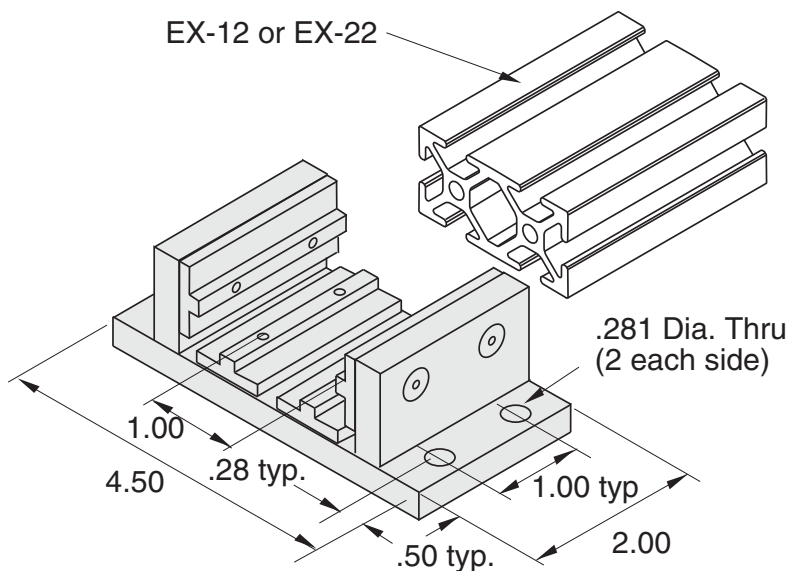
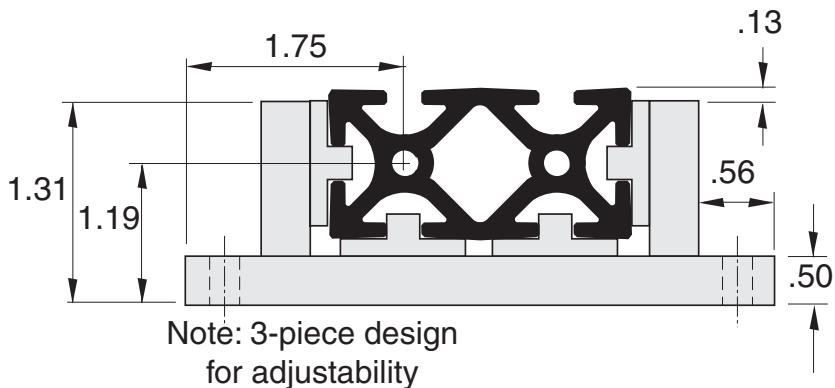

Recommended  
Hardware  
(4) 11-233 BHCS  
(4) 11-205 T-nut

Bearing Material - DELRIN  
Plate Material - Aluminum  
Finish - Clear Anodize

**1/4" SLOTS**

# Single Mount Linear Bearing with Locking Handle



**11-94LH**

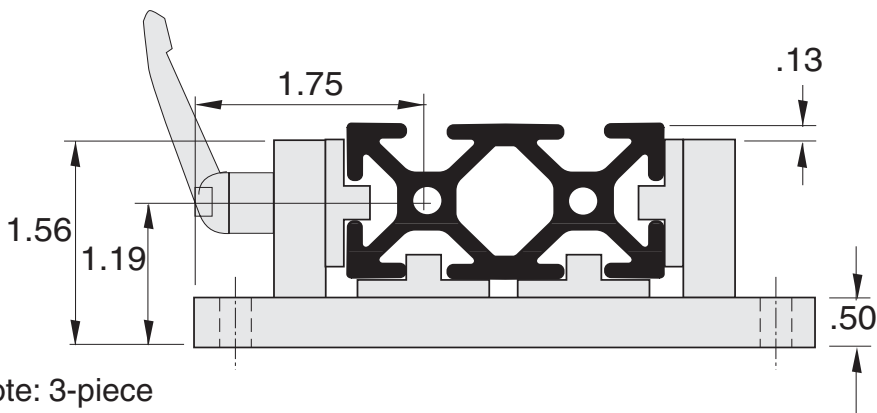

Note: 3-piece  
design for adjust-  
ability

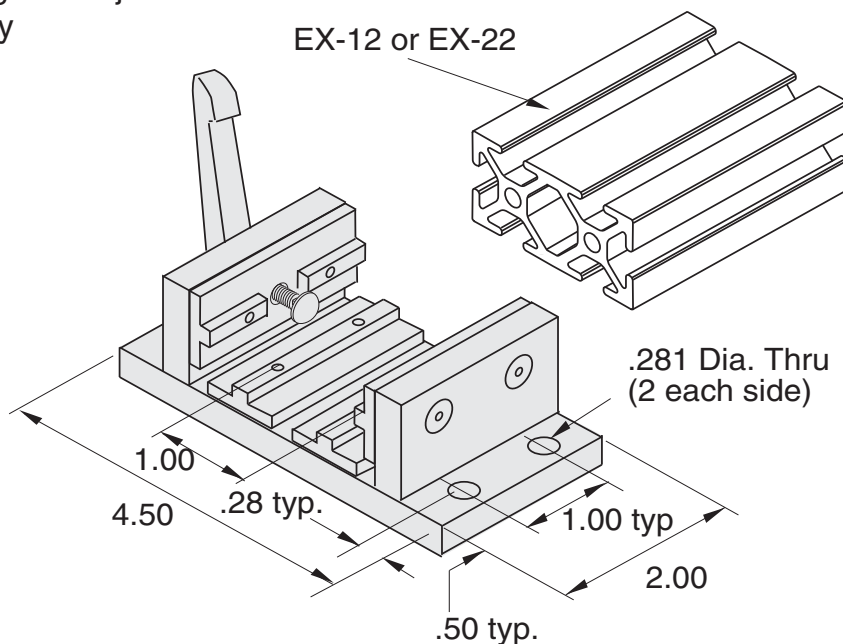

**1/4" SLOTS**

Recommended  
Hardware  
(4) 11-233 BHCS  
(4) 11-205 T-nut

Bearing Material - DELRIN  
Plate Material - Aluminum  
Finish - Clear Anodize

**11-95**

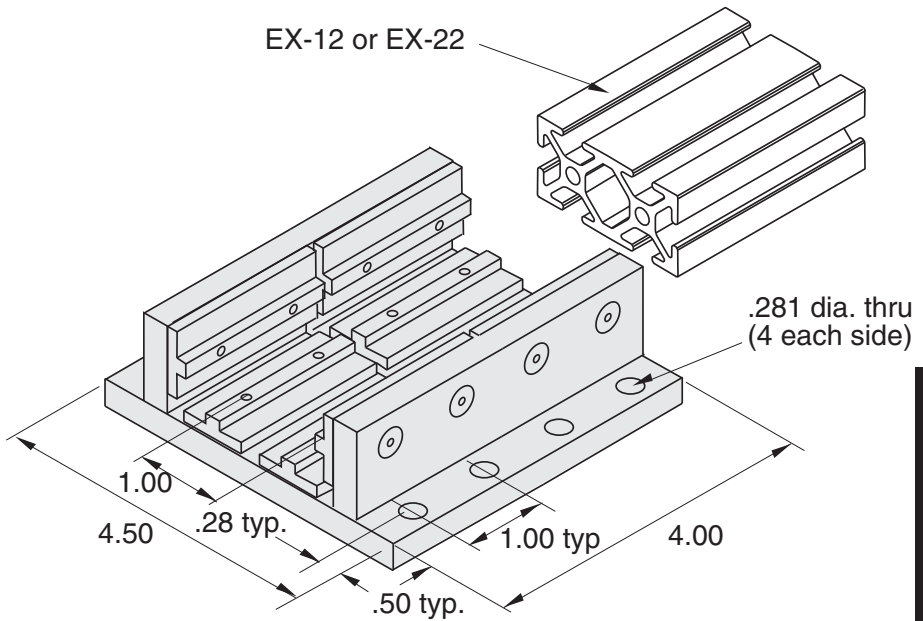
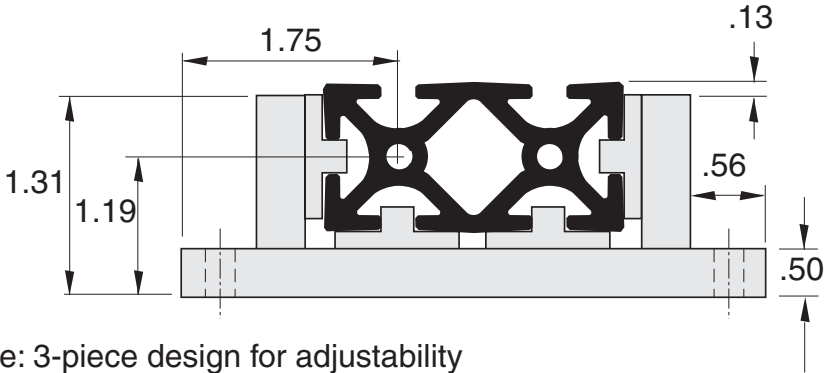

**1/4" SLOTS**

Recommended  
Hardware  
(8) 11-233 BHCS  
(8) 11-205 T-nut

Bearing Material - DELRIN  
Plate Material - Aluminum  
Finish - Clear Anodize



# Double Mount Linear Bearing with Locking Handle



**11-95LH**

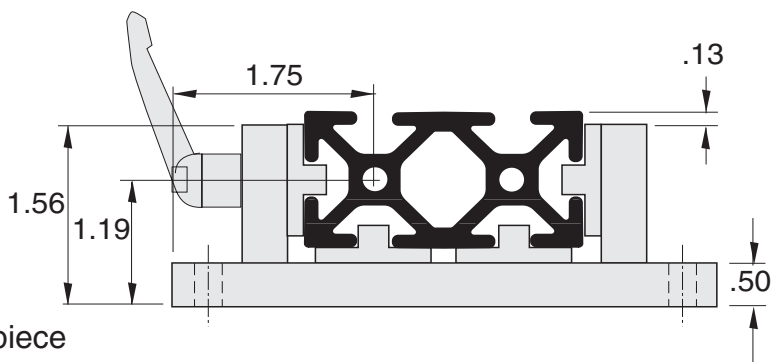

Note: 3-piece design for adjustability

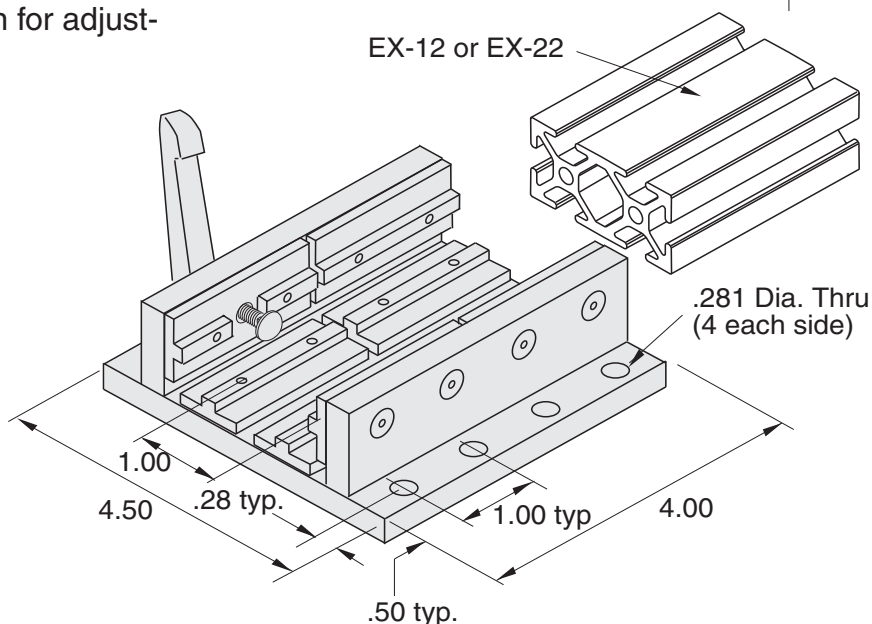

**1/4" SLOTS**

Recommended Hardware  
 (8) 11-233 BHCS  
 (8) 11-205 T-nut

Bearing Material - DELRIN  
 Plate Material - Aluminum  
 Finish - Clear Anodize

with locking handle	<b>11-500</b>
with locking 5/16 SHCS	<b>11-501</b>

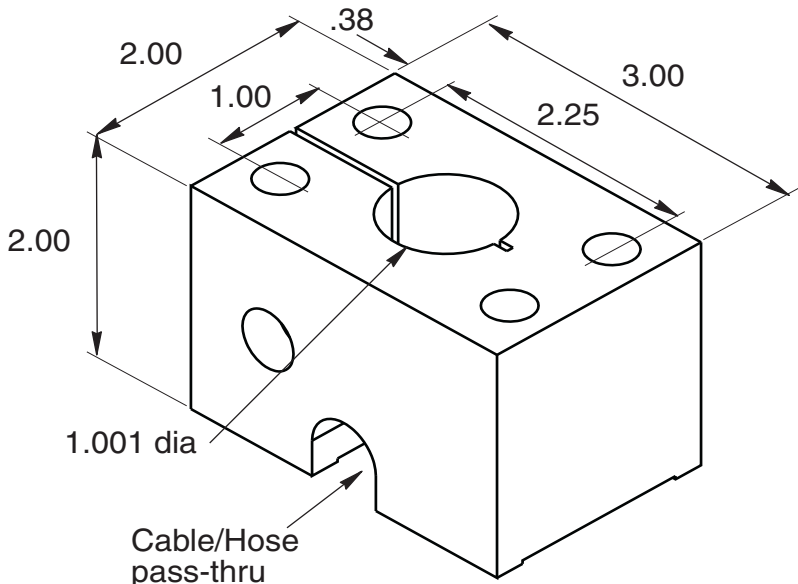

For shafts, see page 496

Recommended  
Hardware  
(4) 11-226 SHCS  
(4) 11-205 T-nut

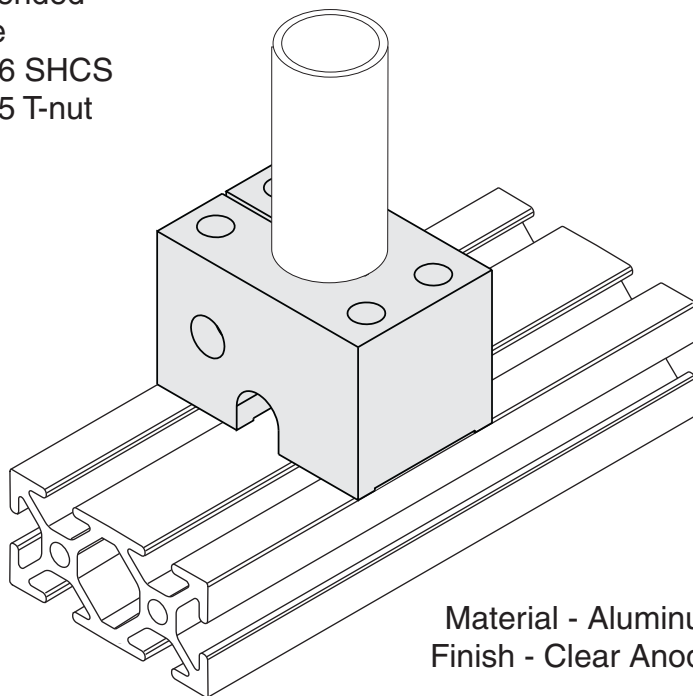

Material - Aluminum  
Finish - Clear Anodize

**1/4" SLOTS**

# Double Shaft Base



<b>11-502</b>	<b>with locking handle</b>
<b>11-503</b>	<b>with locking 5/16 SHCS</b>

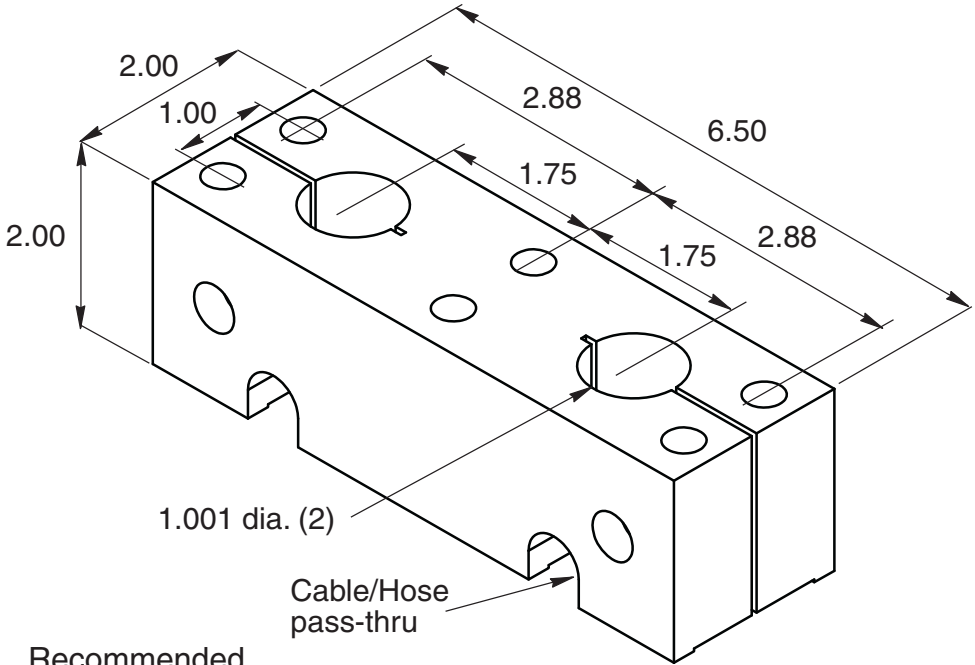

Recommended Hardware

- (6) 11-226 SHCS
- (6) 11-205 T-nut

For shafts, see page 496

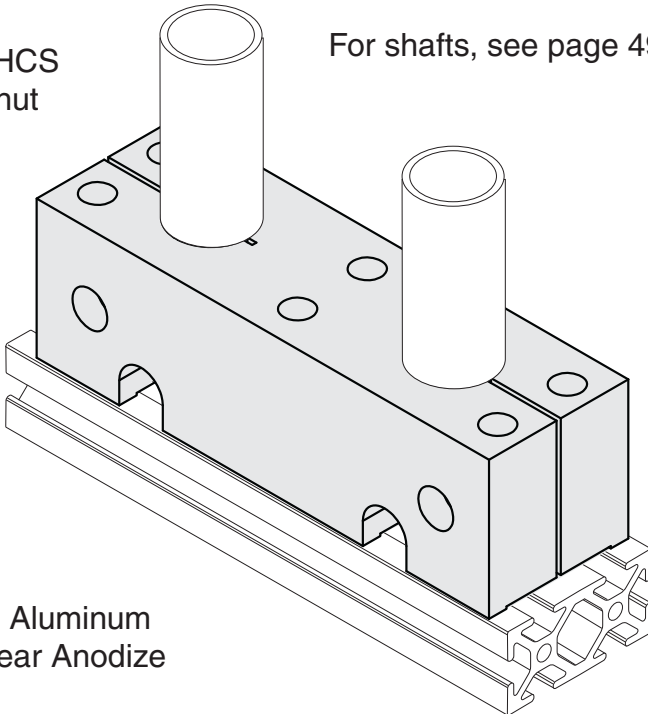

Material - Aluminum  
Finish - Clear Anodize

1/4" SLOTS

with locking handle	<b>11-504</b>
with locking 5/16 SHCS	<b>11-505</b>

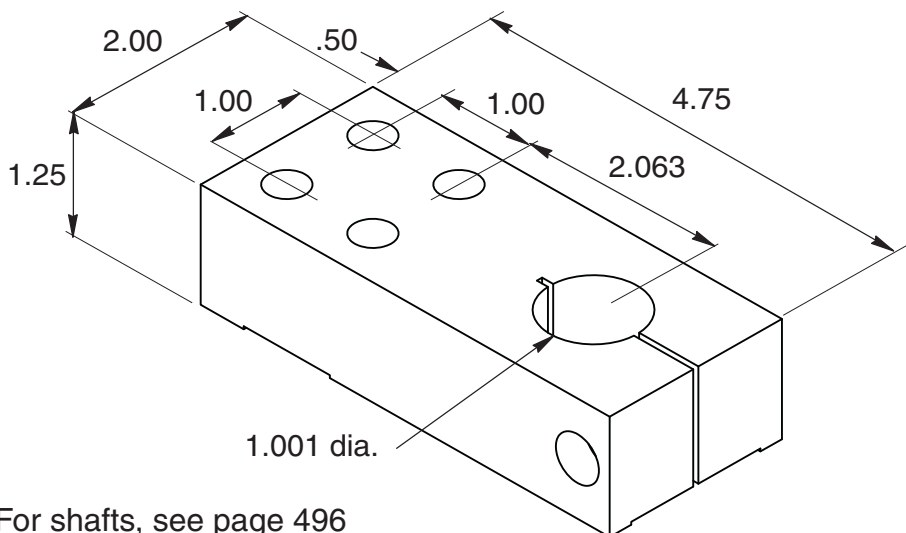

For shafts, see page 496

Recommended  
Hardware  
(4) 11-223 SHCS  
(4) 11-205 T-nut

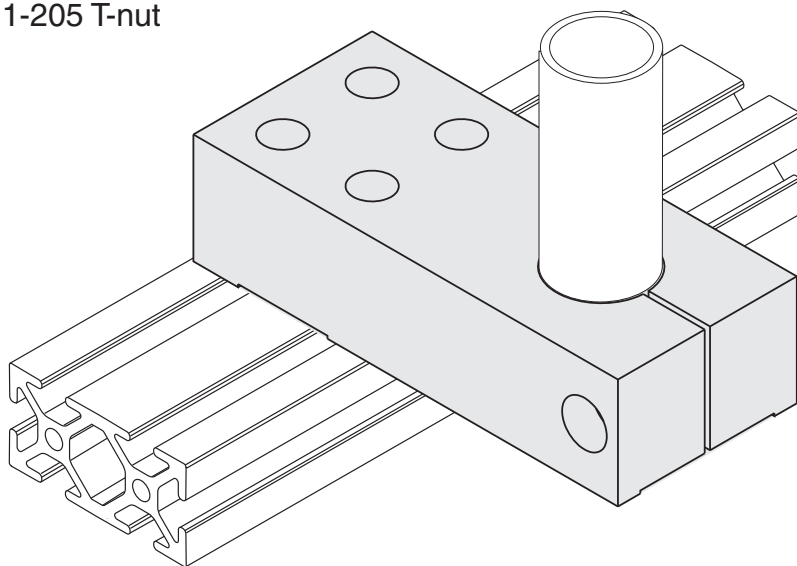

Material - Aluminum  
Finish - Clear Anodize

**1/4" SLOTS**

# Double Shaft Mounting Base



<b>11-506</b>	<b>with locking handle</b>
<b>11-507</b>	<b>with locking 5/16 SHCS</b>

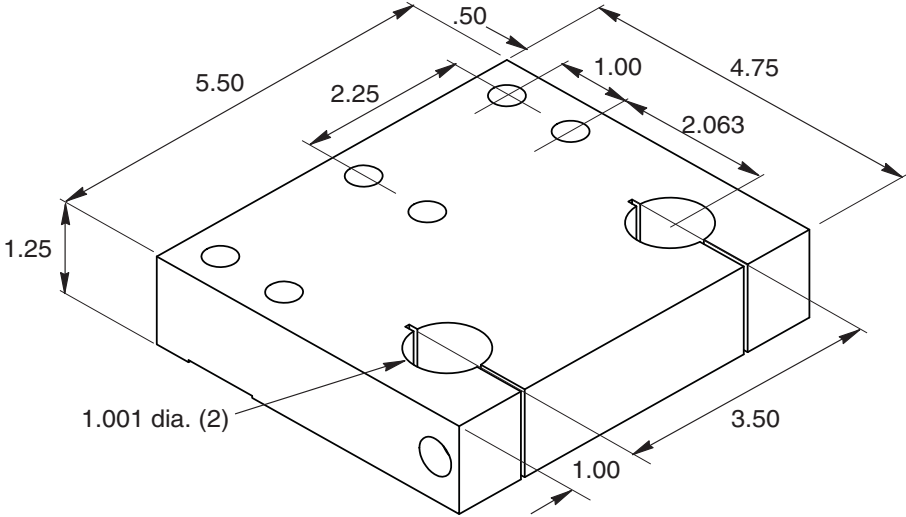

For shafts, see page 496

- Recommended  
Hardware
- (6) 11-223 SHCS
  - (6) 11-205 T-nut

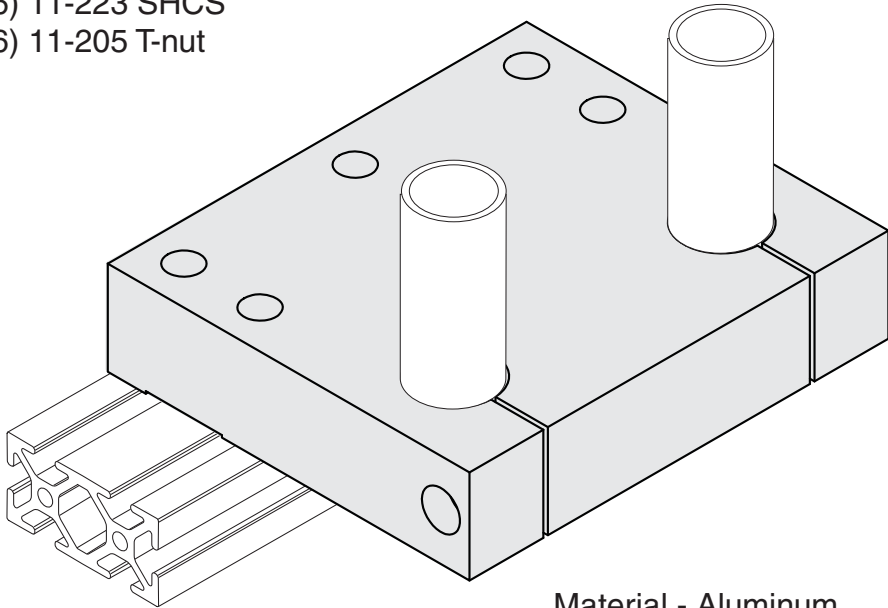

1/4" SLOTS

Material - Aluminum  
Finish - Clear Anodize

with locking handle	<b>11-508</b>
with locking 5/16 SHCS	<b>11-509</b>

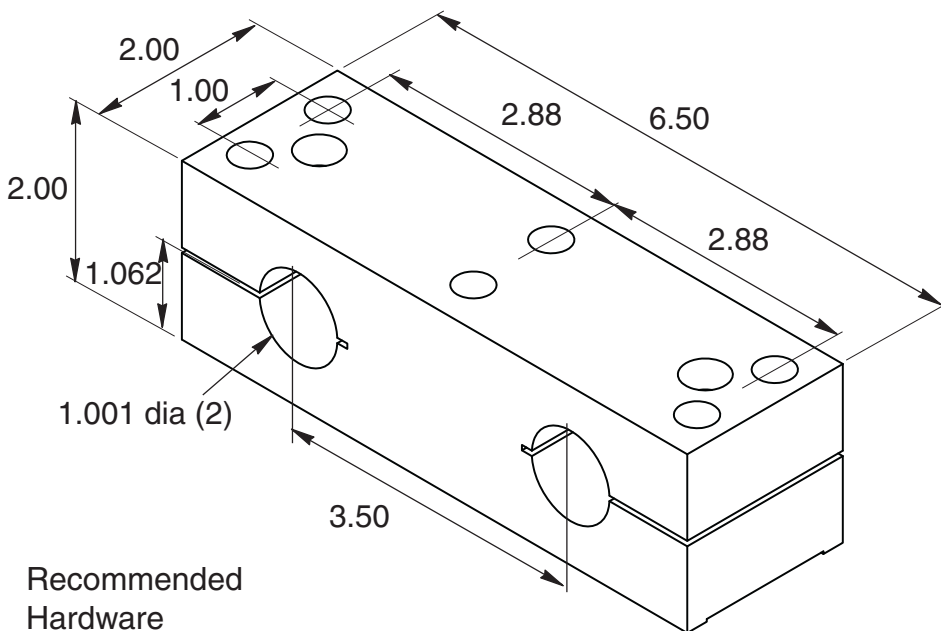

Recommended  
Hardware  
(4) 11-224 SHCS  
(4) 11-205 T-nut

For shafts, see page 496

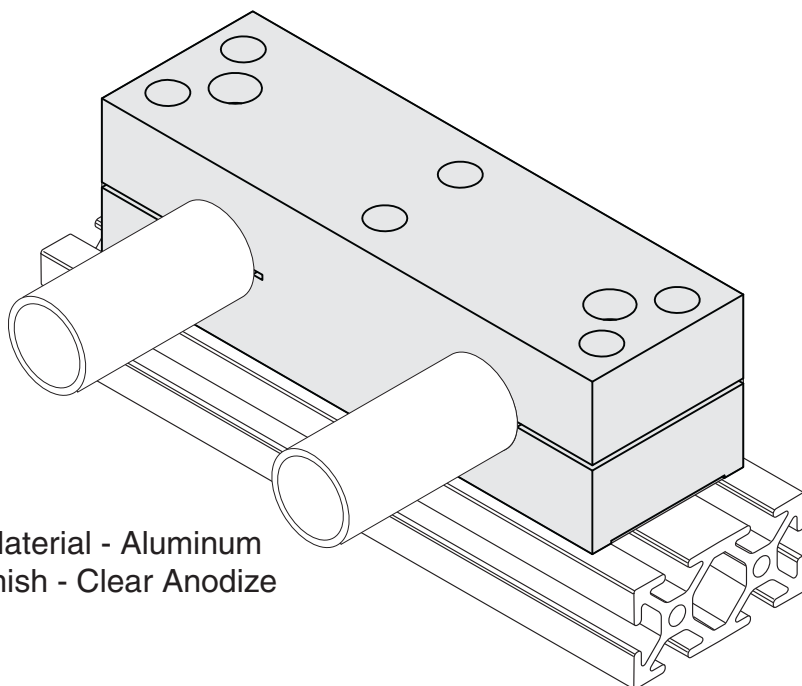

Material - Aluminum  
Finish - Clear Anodize

**1/4" SLOTS**

# Single Shaft Mounting Block



<b>11-510</b>	with locking handle
<b>11-511</b>	with locking 5/16 SHCS

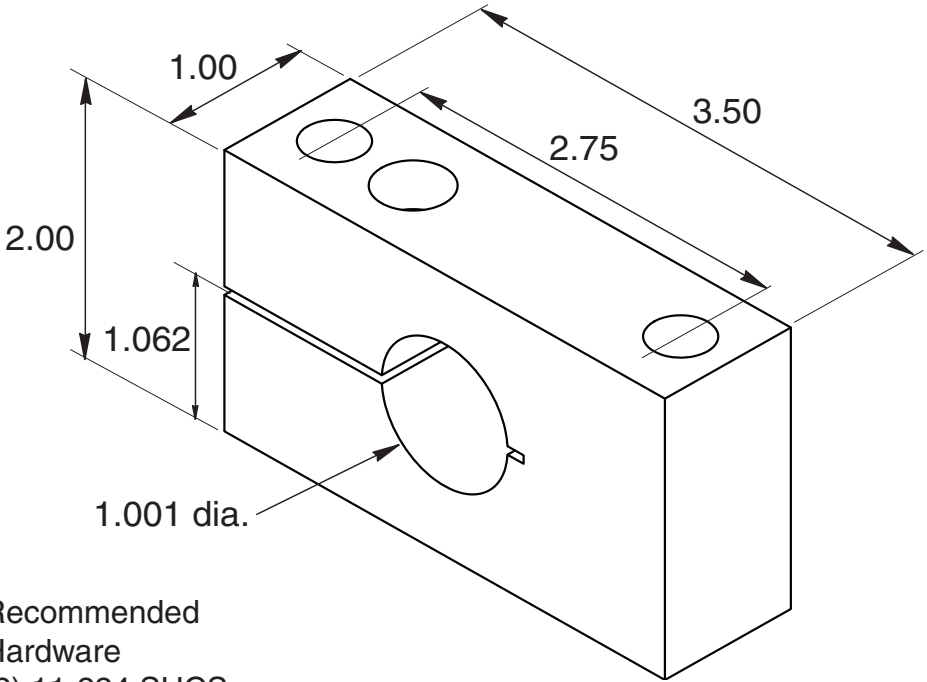

Recommended Hardware  
(2) 11-224 SHCS  
(2) 11-205 T-nut

For shafts, see page 496

**1/4" SLOTS**

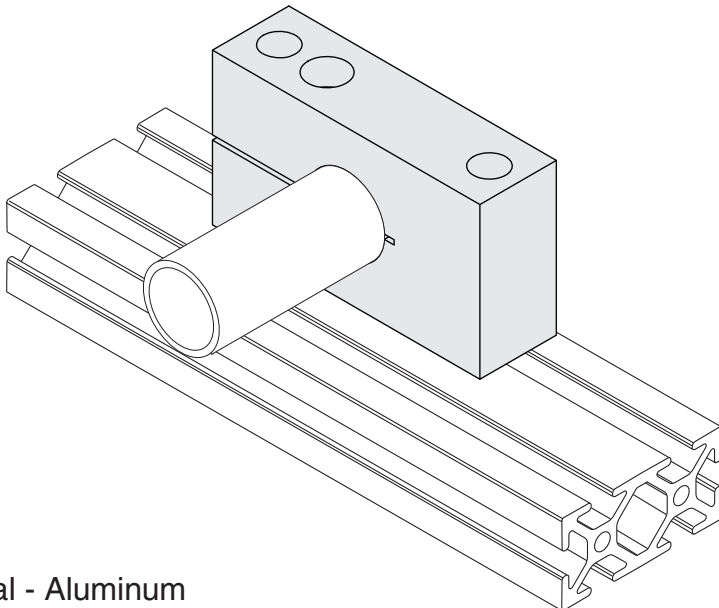

Material - Aluminum  
Finish - Clear Anodize

<b>with locking handle</b>	<b>11-512</b>
<b>with locking 5/16 SHCS</b>	<b>11-513</b>

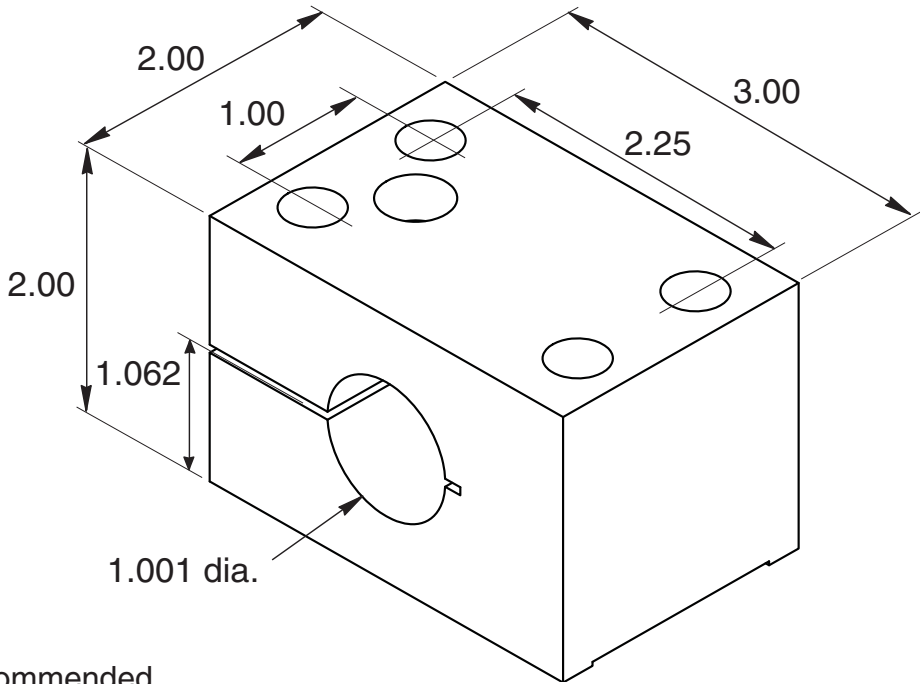

Recommended  
Hardware  
(4) 11-226 SHCS  
(4) 11-205 T-nut

For shafts, see page 496

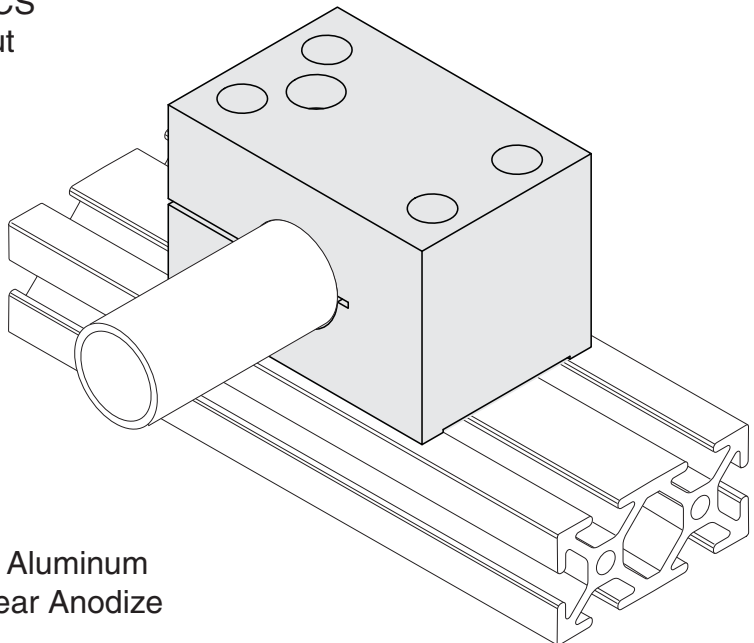

**1/4" SLOTS**

Material - Aluminum  
Finish - Clear Anodize



**EB-218**

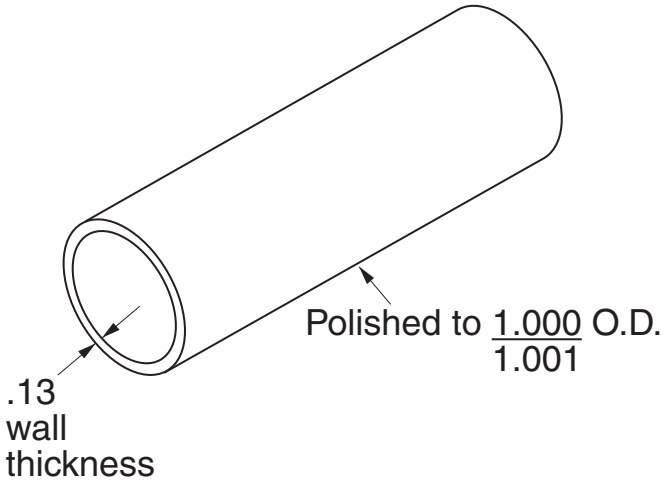

**EB-218** Anodized Aluminum  
Stock Length = 71"

**EB-219** Polished Steel  
Stock Length = 71"

1/4" SLOTS

Note: For any length other than stock length for all of the above, add EM-1 cutting charge

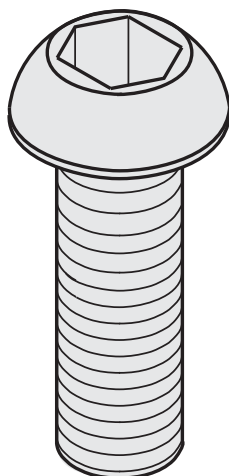

<b>11-230</b>
<b>11-231</b>
<b>11-232</b>
<b>11-233</b>
<b>11-234</b>
<b>11-235</b>

<b>Part No.</b>	
11-230	1/4"-20 thd x 3/8" long
11-231	1/4"-20 thd x 1/2" long
11-232	1/4"-20 thd x 5/8" long
11-233	1/4"-20 thd x 3/4" long
11-234	1/4"-20 thd x 1.0" long
11-235	1/4"-20 thd x 1.25" long

Finish - Black Oxide

**Stainless Steel  
Button Head Cap Screw**

**11-456**

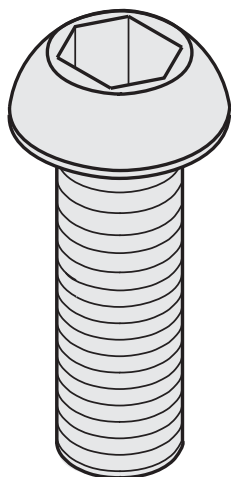

1/4-20 thd
L- inch
<b>11-456 -.38</b>
<b>11-456 -.50</b>
<b>11-456 -.63</b>
<b>11-456 -.75</b>

**1/4" SLOTS**

Metric Button Head Cap Screw



**11-454**

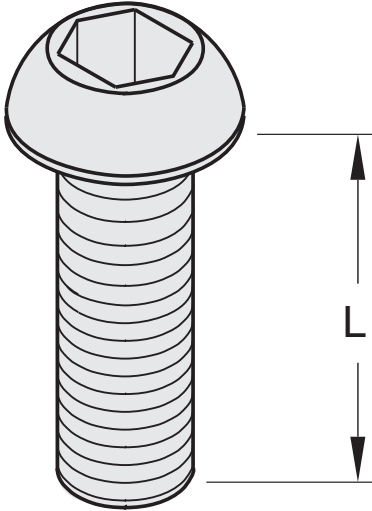

	length
<b>11-454-10</b>	10mm
<b>11-454-12</b>	12mm
<b>11-454-16</b>	16mm
<b>11-454-20</b>	20mm
<b>11-454-25</b>	25mm

m6 thd

Material - Steel  
Finish - Black Oxide

**11-350**  
**11-351**  
**11-352**

**Flanged Button Head Cap Screw**

Part No.	
11-350	$\frac{1}{4}$ -20 thd x $\frac{3}{8}$ " long
11-351	$\frac{1}{4}$ -20 thd x $\frac{1}{2}$ " long
11-352	$\frac{1}{4}$ -20 thd x $\frac{3}{4}$ " long

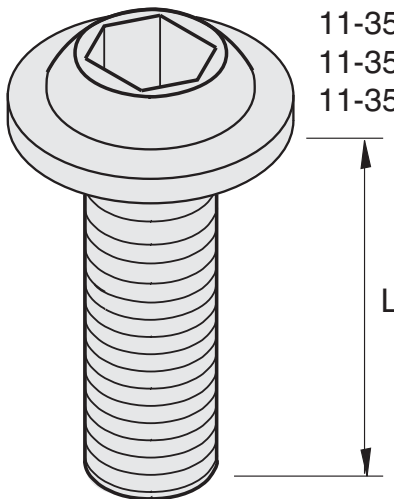

Finish - Black Oxide

1/4" SLOTS

<b>11-220</b>
<b>11-221</b>
<b>11-222</b>
<b>11-223</b>
<b>11-224</b>
<b>11-225</b>
<b>11-226</b>

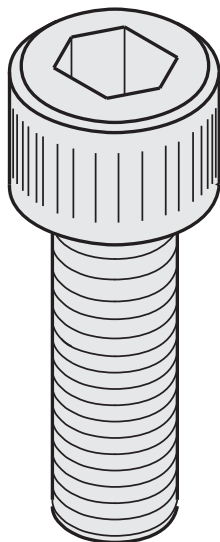

<b>Part No.</b>	
11-220	$\frac{1}{4}$ -20 thd x $\frac{3}{8}$ " long
11-221	$\frac{1}{4}$ -20 thd x $\frac{1}{2}$ " long
11-222	$\frac{1}{4}$ -20 thd x $\frac{5}{8}$ " long
11-223	$\frac{1}{4}$ -20 thd x $\frac{3}{4}$ " long
11-224	$\frac{1}{4}$ -20 thd x 1.0" long
11-225	$\frac{1}{4}$ -20 thd x 1.25" long
11-226	$\frac{1}{4}$ -20 thd x 1.50" long

**1/4" SLOTS**

**Finish - Black Oxide**

# Metric Socket Head Cap Screw



**11-450**

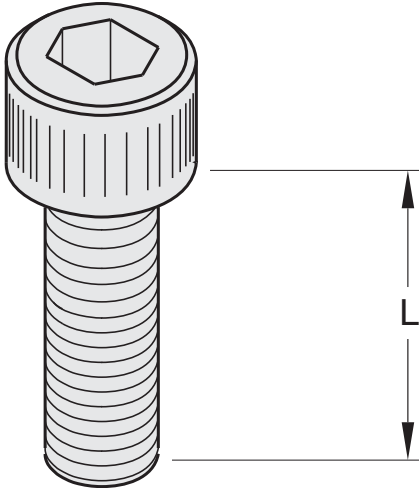

m6 thd

	length
<b>11-450-10</b>	10mm
<b>11-450-12</b>	12mm
<b>11-450-16</b>	16mm
<b>11-450-20</b>	20mm
<b>11-450-25</b>	25mm

Material - Steel  
Finish - Black Oxide

# Stainless Steel Socket Head Cap Screw

**11-452**

**1/4" SLOTS**

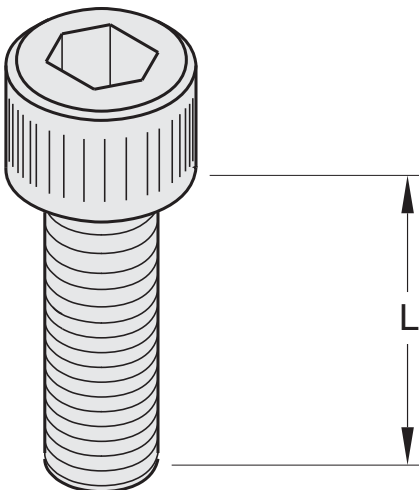

1/4-20 thd

	L-inch
<b>11-452 -.5</b>	
<b>11-452 -.63</b>	
<b>11-452 -.75</b>	
<b>11-452 -1.0</b>	

**Socket Head** **11-220K**

Fractional  
(1/4 - 20 thd)

Part No	Thread Length
11-220K	.375
11-221K	.50
11-222K	.63
11-223K	.75
11-224K	1.00

Metric  
(M6 x 1.0 thd)

Part No	Thread Length
11-450K-10	10
11-450K-12	12
11-450K-16	16
11-450K-20	20
11-450K-25	25

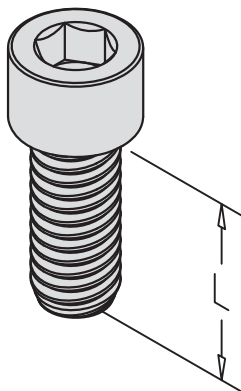

Material - Steel  
Finish - Bright Zinc Plated

**Button Head** **11-230K**

Fractional  
(1/4 - 20 thd)

Part No	Thread Length
11-230K	.375
11-231K	.50
11-232K	.63
11-233K	.75
11-234K	1.00

Metric  
(M6 x 1.0 thd)

Part No	Thread Length
11-454K-10	10
11-454K-12	12
11-454K-16	16
11-454K-20	20
11-454K-25	25

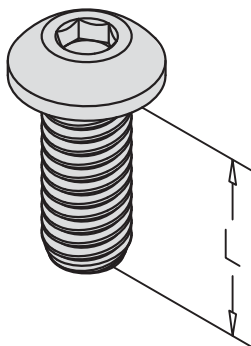

Material - Steel  
Finish - Bright Zinc Plated

**1/4" SLOTS**

## Zinc Plated Hex Cap Screw



**11-458**

Fractional  
(1/4" - 18 thd) L = inch

11-458-.38  
11-458-.50  
11-458-.63  
11-458-.75  
11-458-1.00  
11-458-1.25

Material - Steel  
Finish - Bright Zinc Plated

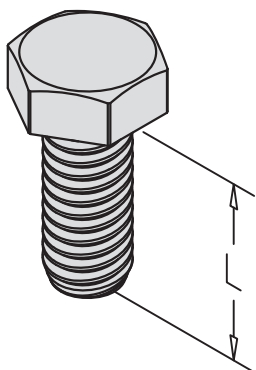

Metric  
(M6 x 1.25 thd) L = mm

11-458M-12  
11-458M-16  
11-458M-20  
11-458M-25  
11-458M-30

Material - Steel  
Finish - Yellow Zinc Plated

## Flat Head Socket Cap Screws

**EF-157**

1/4-20 thd.

**EF-158**

#10-32 thd.

**Steel**

(1/4" - 20 thd) L = inch

EF-157-.50  
EF-157-.63  
EF-157-.75  
EF-157-1.0

(#10-32 thd) L = inch

EF-158-.50  
EF-158-.63

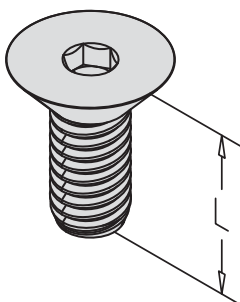

**Stainless Steel**

(1/4" - 20 thd) L = inch

EF-157SS-.50  
EF-157SS-.63

(#10-32 thd) L = inch

EF-158SS-.50  
EF-158SS-.63

Material - Steel  
Finish - Black Oxide

Material - Stainless Steel

<b>11-210</b>
<b>11-211</b>
<b>11-212</b>
<b>11-213</b>
<b>11-214</b>
<b>11-239</b>

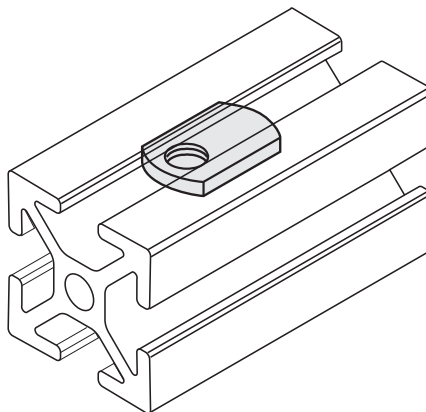

- Part No.  
**11-210** 1/4-20 thd  
**11-211** 10-32 thd  
**11-212** m6 thd  
**11-213** 8-32 thd  
**11-214** 6-32 thd  
**11-239** m5 thd

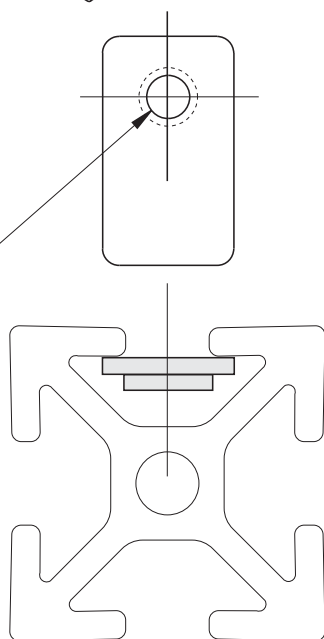

**1/4" SLOTS**

**Material - Steel**  
**Finish - Zinc Plated**



# Economy T-Nut (Centered Thread)



<b>11-215</b>
<b>11-216</b>
<b>11-217</b>
<b>11-219</b>
<b>11-215SS</b>

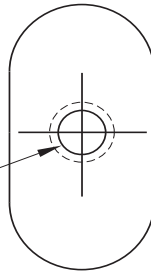
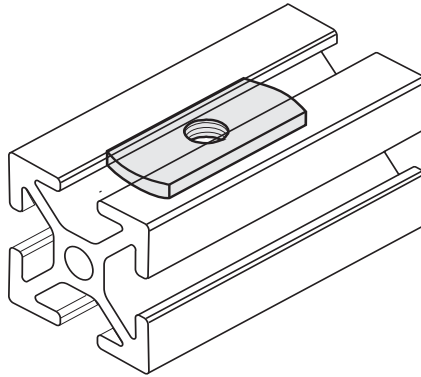

- Part No.  
**11-215** 1/4-20 thd  
**11-216** 10-32 thd  
**11-217** 8-32 thd  
**11-219** 6-32 thd  
**11-215SS** 1/4-20 thd  
 Stainless  
 Steel T-nut

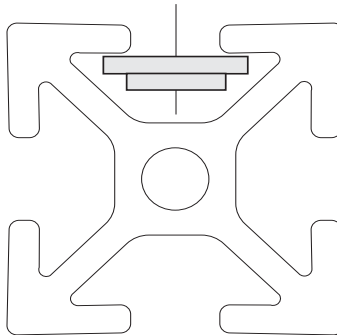

**1/4" SLOTS**

Material - Steel  
 Finish - Zinc Plated

1/4-20 thd (x2)

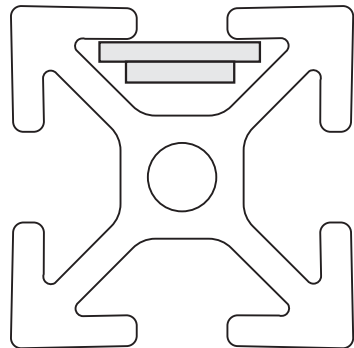
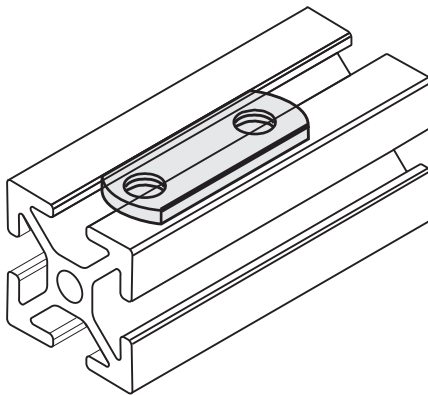
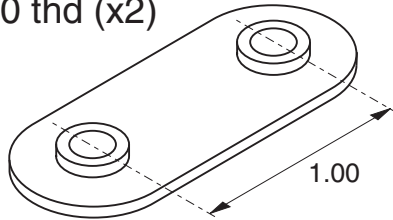

**1/4" SLOTS**

Material - Steel  
Finish - Zinc Plated

# Pivot T-Nut with Rubber Bumper



11-201
11-202
11-203
11-227

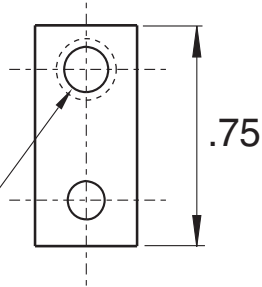
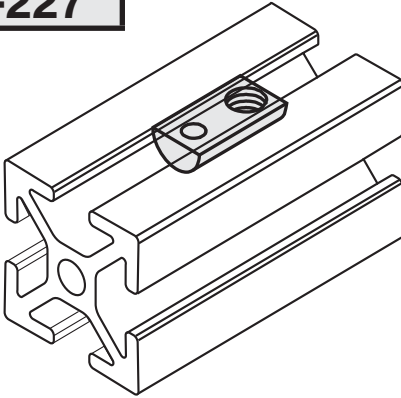

- Part No.  
**11-201** 1/4-20 thd  
**11-202** 10-32 thd  
**11-203** m6 thd  
**11-227** 8-32 thd

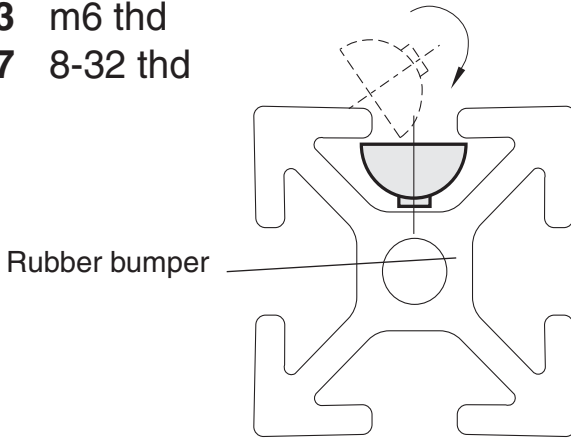

1/4" SLOTS

Material - Steel  
Finish - Zinc Plated

<b>11-340</b>
<b>11-341</b>
<b>11-342</b>

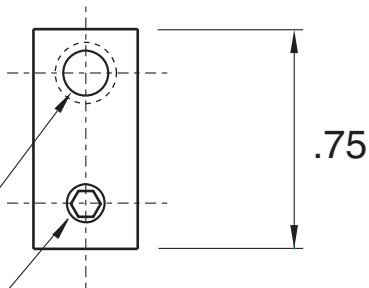
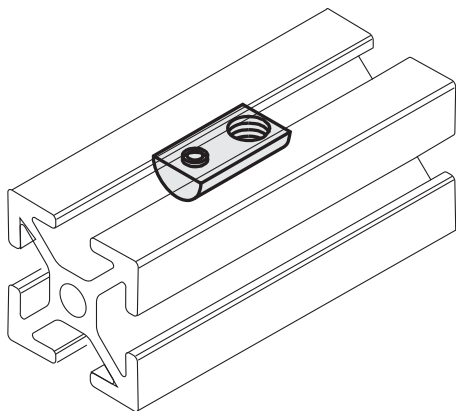

- 11-340** 1/4-20 thd
- 11-341** 10-32 thd
- 11-342** m6 thd

10-32 setscrew  
included

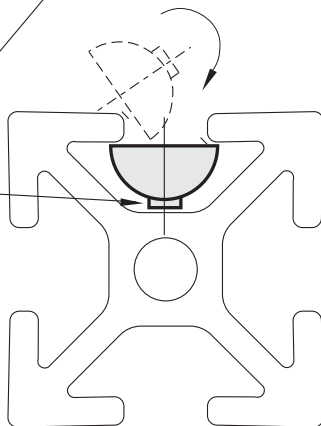

**1/4" SLOTS**

Material - Steel  
Finish - Zinc Plated

# Heavy Duty T-Nut



<b>11-205</b>
<b>11-206</b>
<b>11-207</b>
<b>11-208</b>
<b>11-209</b>

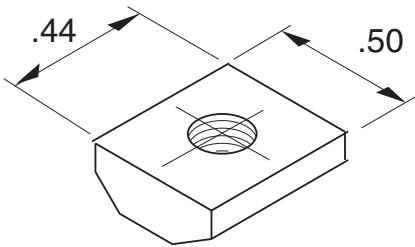

- 11-205** 1/4-20 thd
- 11-206** 10-32 thd
- 11-207** m6 thd
- 11-208** 8-32 thd
- 11-209** 6-32 thd

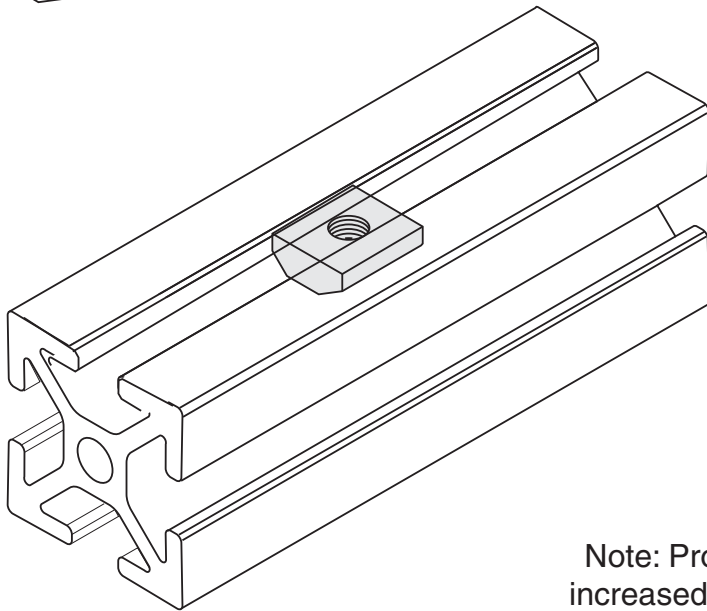

Note: Provides increased thread engagement

Material - Steel  
Finish - Zinc Plated

1/4" SLOTS

.26 slot width

**11-218**

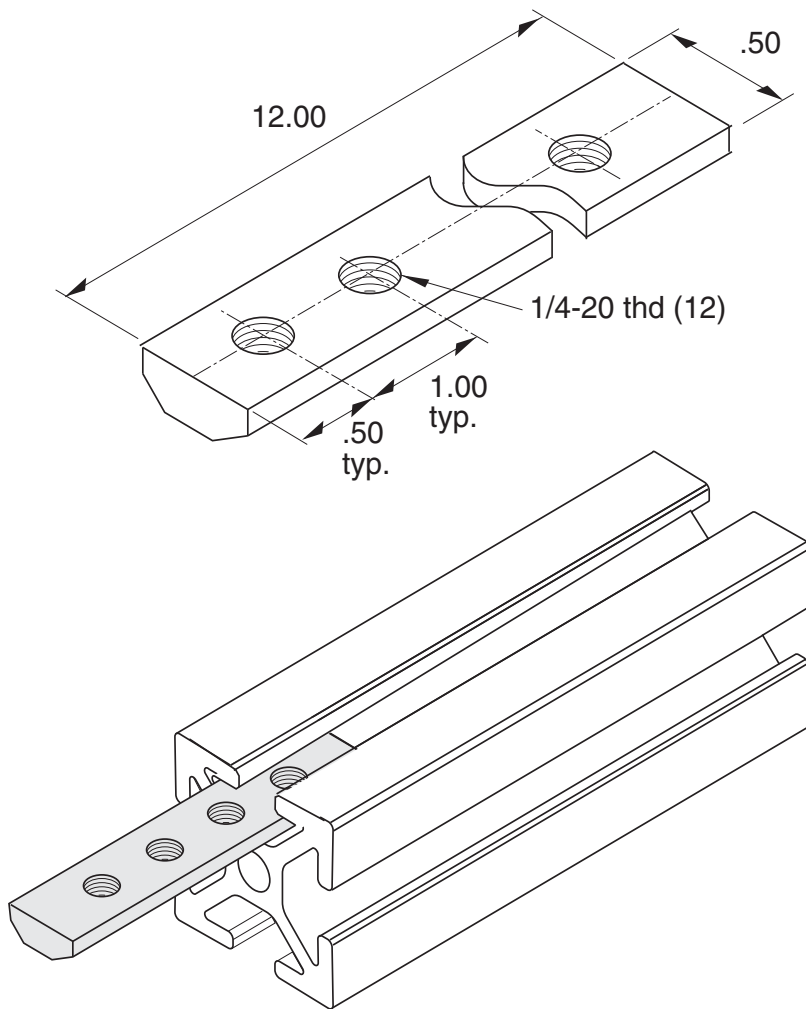

Special Lengths can be provided on request  
Material is zinc plated steel

Material - Steel  
Finish - Zinc Plated

**1/4" SLOTS**

# Blank Continuous T-nut



**11-218B** .25 inch slot size

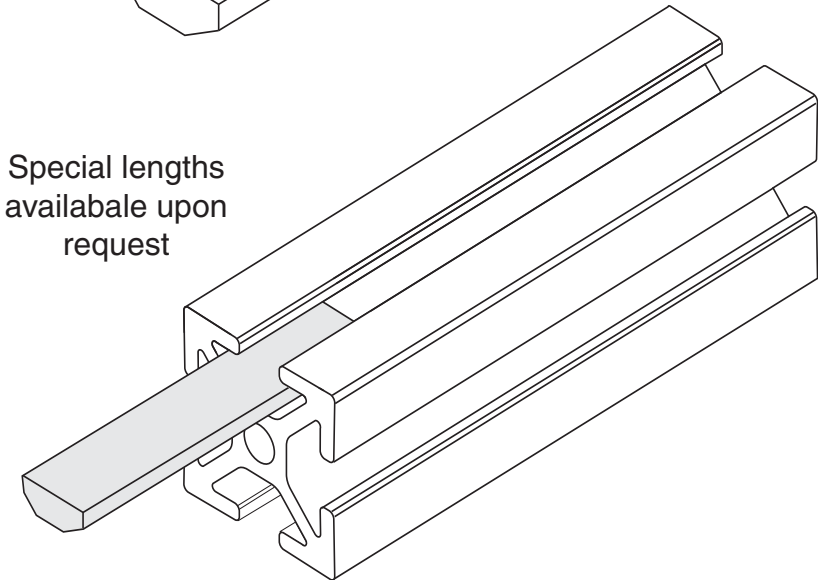
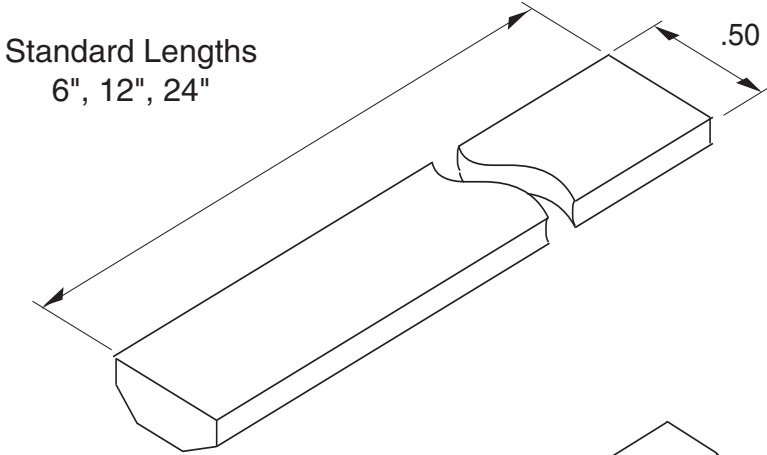

Note: Factory supplied tapped  
holes can be supplied per  
customer specification

Material - Steel  
Finish - Zinc Plated

1/4" SLOTS

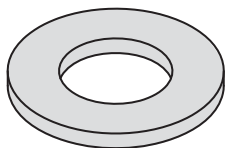

- 11-240** Washer Hardened Steel Heavy Duty (Black Oxide)
- 11-240SS** Washer (Stainless Steel)
- 11-240S** Washer (Zinc Plated)

Material - Steel  
Finish - Black Oxide

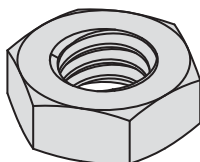

- 11-241** 1/4-20 Hex Nut
- 11-241M** M6-1.0 Hex Nut

Material - Steel  
Finish - Zinc Plated

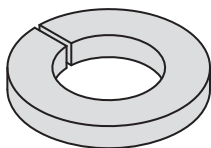

- 11-240L** Locking Washer

Material - Steel  
Finish - Zinc Plated



# Plastic End Plates



<b>11-250</b>
<b>11-257</b>
<b>11-258</b>
<b>11-259</b>
<b>11-277</b>

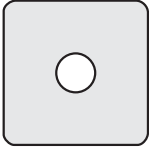

**11-250**  
use with Extrusion EX-11

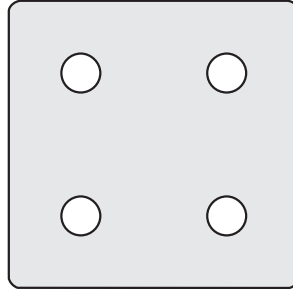

**11-258**  
use with Extrusion EX-22

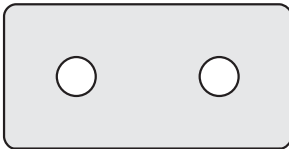

**11-257**  
use with Extrusion EX-12

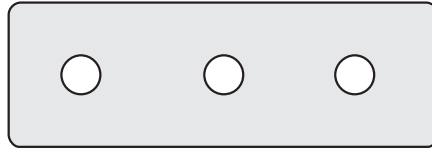

**11-259**  
use with Extrusion EX-13

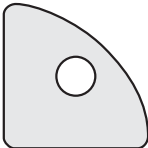

**11-277**  
use with Extrusion EX-14

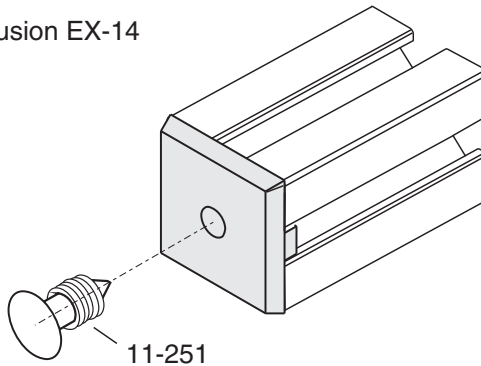

Note: For metal covers,  
consult the factory

Push Lock Fasteners  
Included with each end plate

Material - Black ABS

1/4" SLOTS

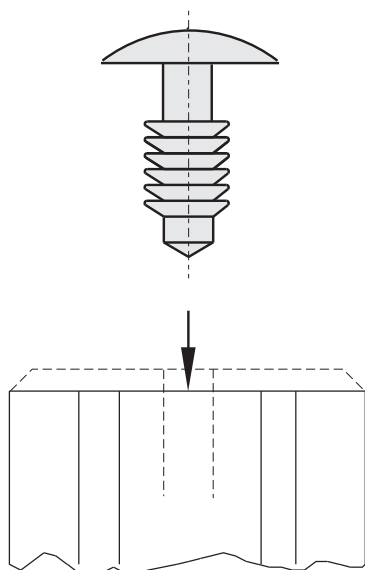

Note: thread bolt hole for permanent installation

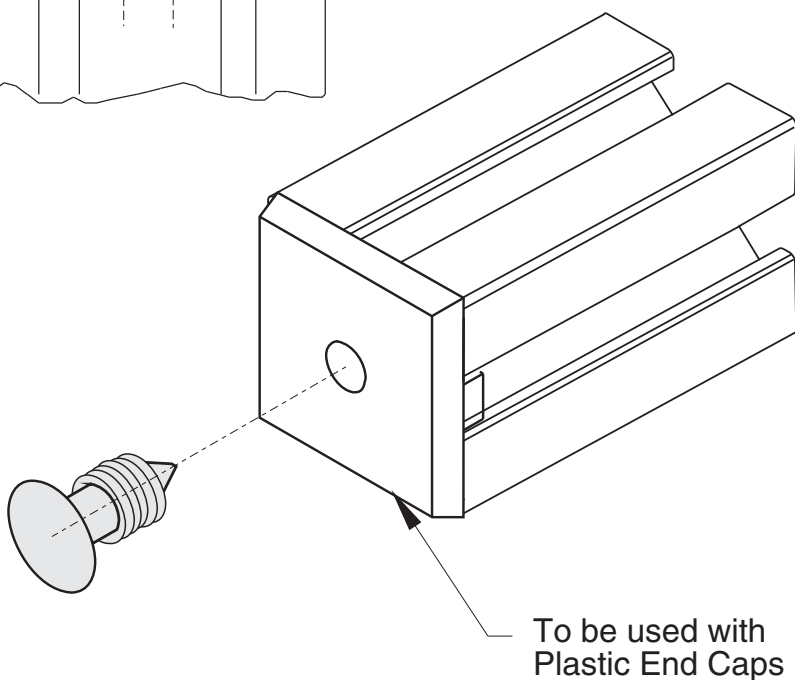

To be used with Plastic End Caps

**1/4" SLOTS**

Material - Nylon

# Pressure Manifold Plate



**11-100**

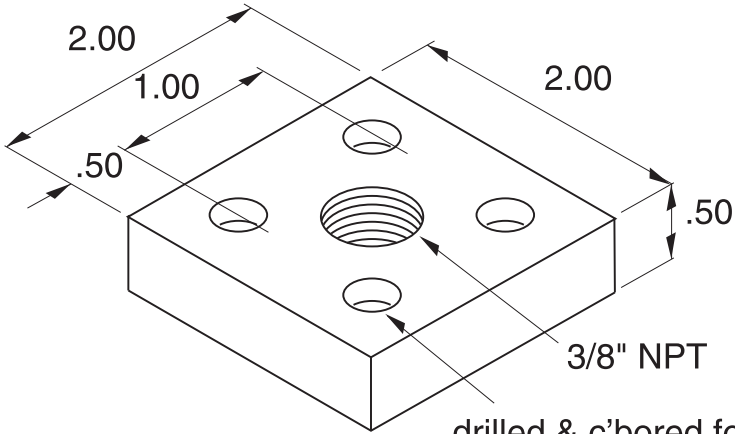

Cross Sectional  
Area = 1.63 sq. in.

drilled & c'bored for  
1/4-20 shcs (4)

Note: for side porting,  
use 11-101 or 11-102

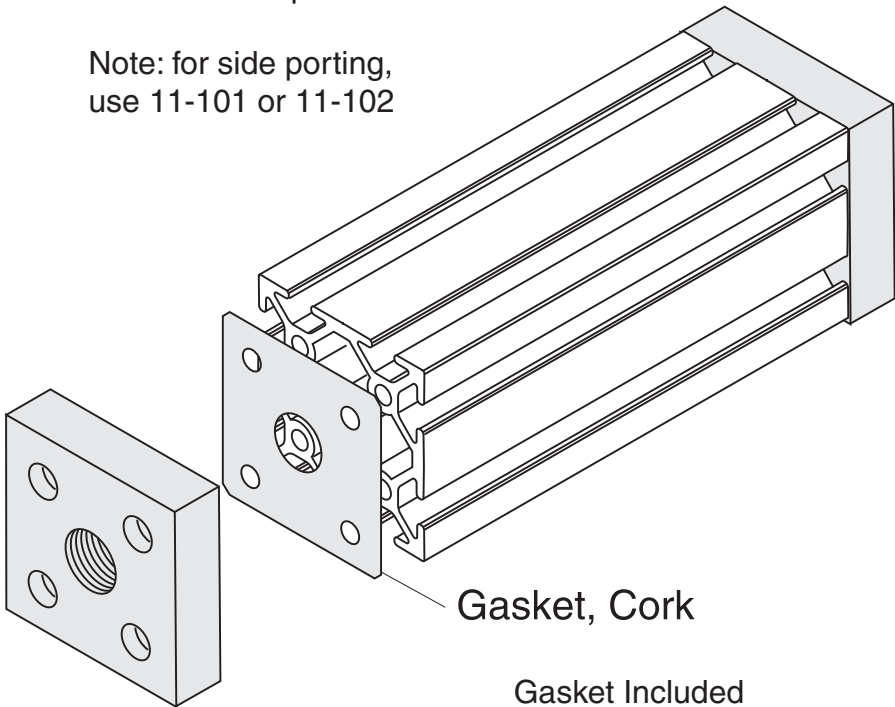

Gasket, Cork

Gasket Included  
Requires (4)11- 224 SHCS

Material - Aluminum  
Finish - Clear Anodize

**11-101**

**11-102**

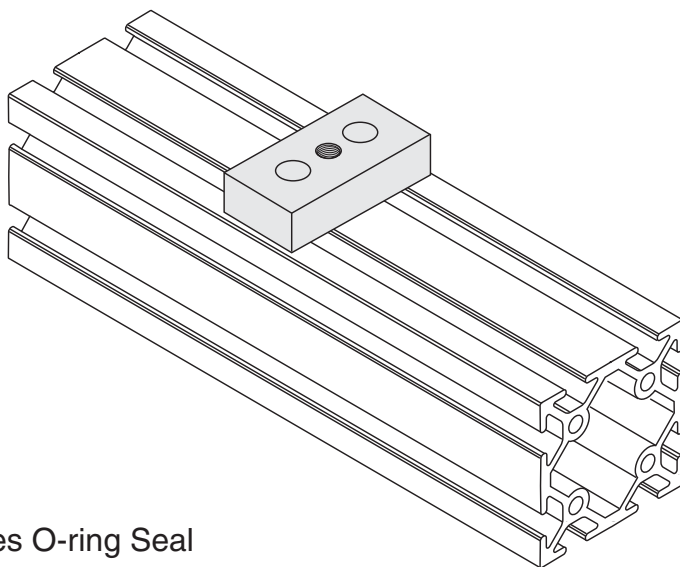
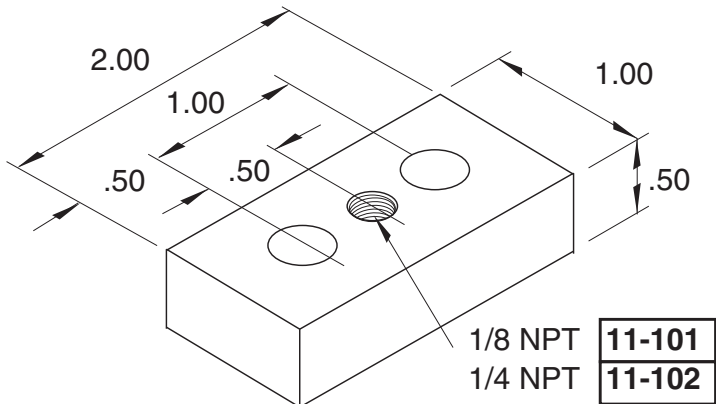

Includes O-ring Seal

Requires

(2) 11-221 SHCS

(2) 11-210 T-Nut

O-ring Material - Buna N

Material - Aluminum

Finish - Clear Anodize

**1/4" SLOTS**

# Hanger Clip



11-190

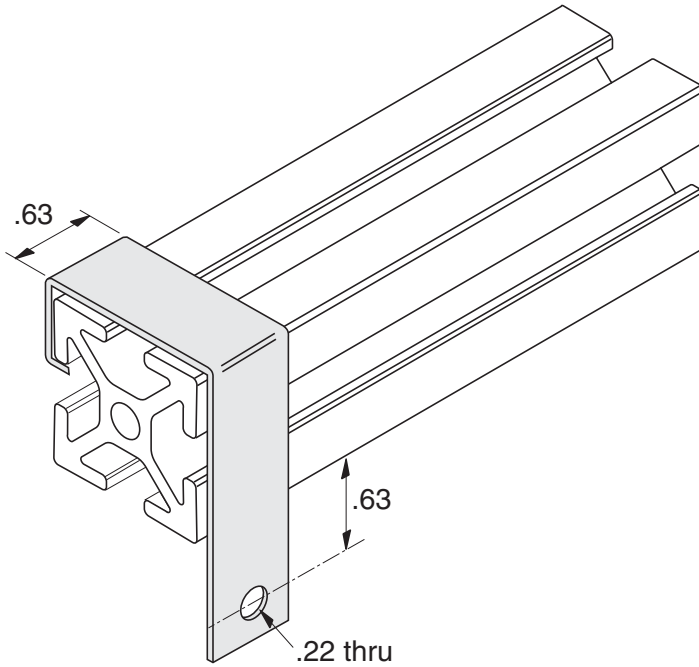

1/4" SLOTS

Material Steel  
Finish: Zinc Plated

use on all 1/4" slot extrusions  
with 1.0" sides

**11-320**

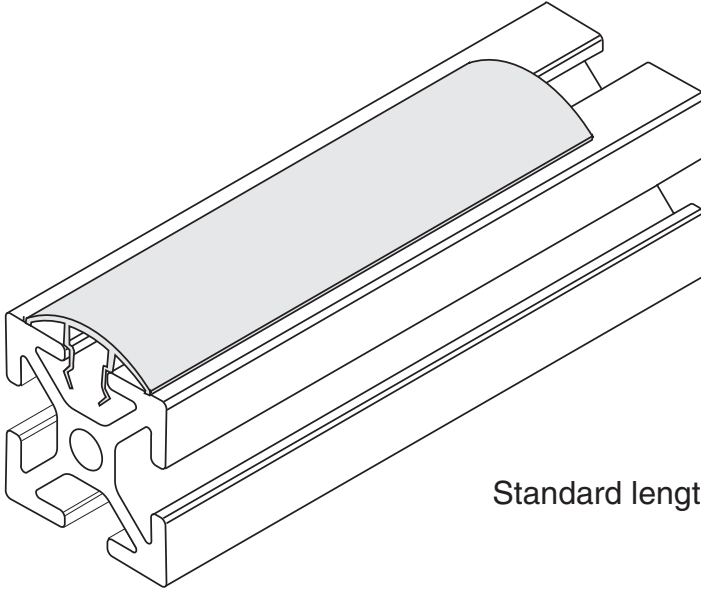

Standard length 72"

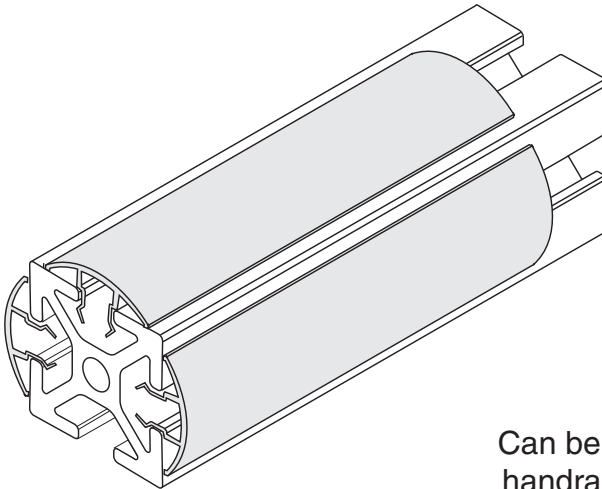

Can be used as  
handrail covers

Material - Rigid PVC  
Color - Black

**1/4" SLOTS**

# Drill Fixture



<b>11-150</b>
<b>11-151</b>

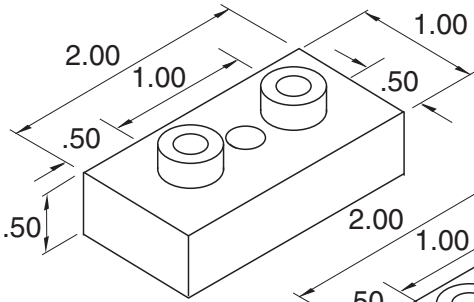

Hardware Included

**11-150**

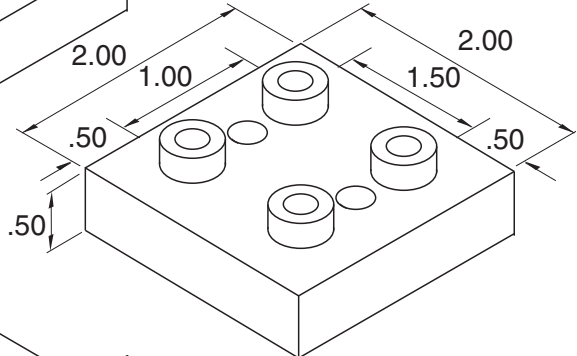

**11-151**

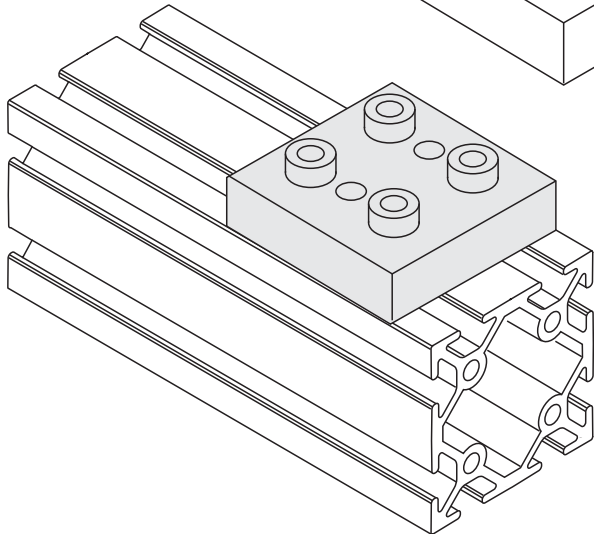

**1/4" SLOTS**

Use on EX-11, EX-12, EX-13, EX-22 for drilling access holes for universal style corners

Material - Aluminum  
Finish - Clear Anodize





## FRAME-WORLD Extruded Aluminum Specifications and Tolerances

- **Flatness:** within .004" per inch of width
- **Twist:** will not exceed .25° per foot with a maximum of 1.5° total in (16) feet.
- **Straightness:** within .0125" per foot and within a maximum of .120 in (16) feet
- **Length:** +.125" for standard length  
+.015" for cut pieces
- **Yield Strength:** 35,000 PSI
- **Tensile Strength:** 38,000 PSI
- **Surface Finish:** Etch and clear anodize standard  
Powder Coating in color is also available.

## Metric Sizes for FRAME-WORLD Extrusions and Accessories

FRAME-WORLD extrusions and accessories are designed using standard American dimensions, and use American dimension fasteners. Metric size fasteners are stocked as catalog items and conversion of extrusion profile to nominal or nearest metric size in whole mm is simple: 1 inch = 25 mm, 1.5 inches = 38 mm, 3 inches = 76 mm.

## Self Locking Feature (5/16" wide slots)

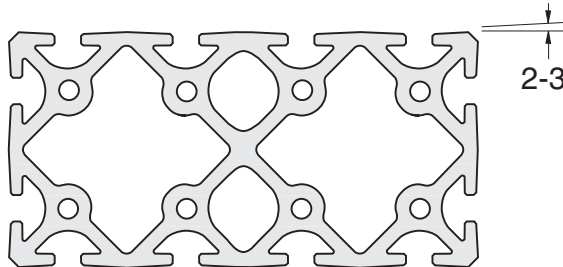

Our EX-1, EX-2, EX-26, EX-3 and EX-36 extrusion has a 2-3 degree decline form the extrusion edge to slot centerline.

## Self Locking Feature (5/16" wide slots)

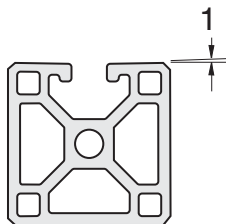

Our EX-6, EX-7, EX-8, EX-52, EX-54, EX-61, EX-63, EX-64, EX-65, EX-66, EX-67, EX-68 and EX-69 extrusions have a 1 degree decline from the extrusion edge.

When fasteners are properly tightened, this feature serves as a lock mechanism to form a shake-proof connection.

### Recommended torque on fasteners

5/16-18 or m8 thread - 15 to 20 ft/lbs.

## Self Locking Feature (1/4" wide slots)

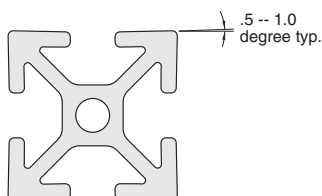

The FRAME-WORLD EX-11, EX-12, EX-13, EX-14, EX-22, EX-70, EX-71, EX-72, EX-73 and EX-24 extrusions have a .5 – 1.0 degree decline from extrusion edge to slot centerline.

This feature serves as a lock mechanism forming a shake-proof connection to keep all fasteners tight.

### Recommended torque on fasteners

1/4-20 or m6 thread - 12 to 17 ft/lbs.

## EX-1

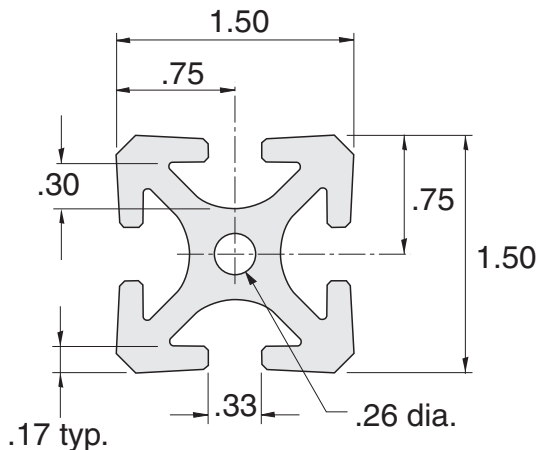

- Finish = Clear anodized
- Material = 6105-T5 Aluminum
- Est. Area = 1.164 Sq. In.
- Weight/ft = 1.4522 lbs.
- 96", 144.25", 192.63" Lengths standard.

### Section Properties:

Moment of Intertia in <sup>4</sup>	.242
Section modulus in <sup>3</sup>	.323

Load condition:  
Fixed at both ends, load at center  
Deflection = y (inches)

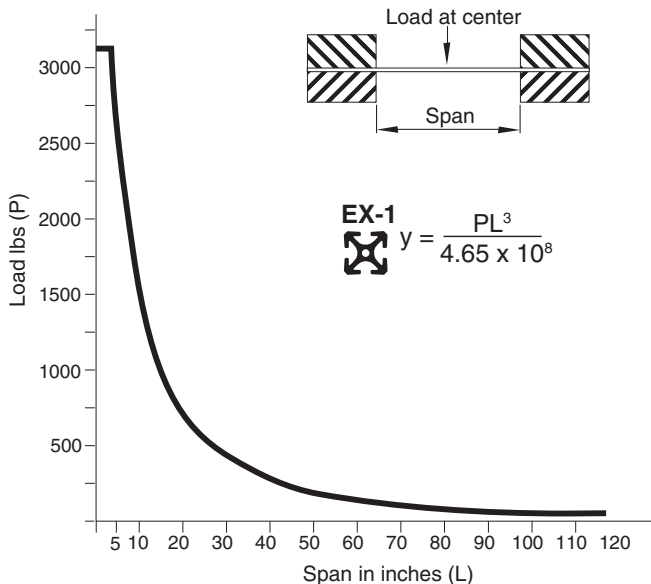

**EX-1**

Load condition:  
Fixed at one end, sliding at one end,  
load at center  
Deflection = Y (inches)

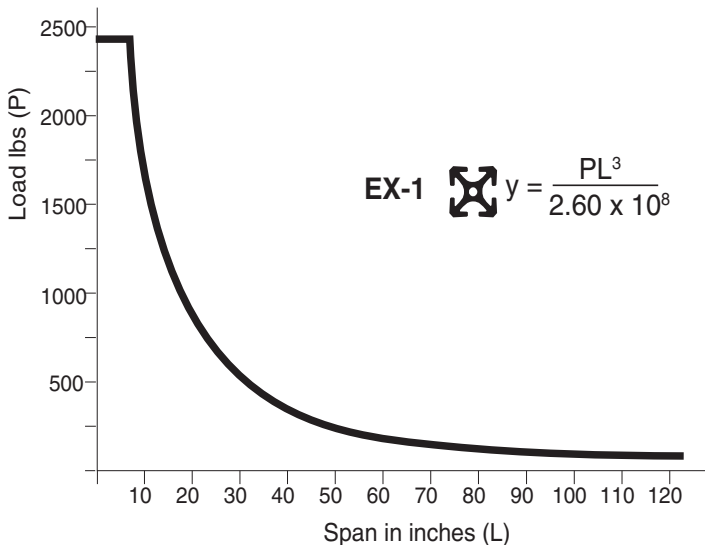
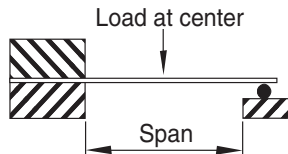

Load condition:  
Fixed at one end,  
load at unsupported end  
Deflection = Y (inches)

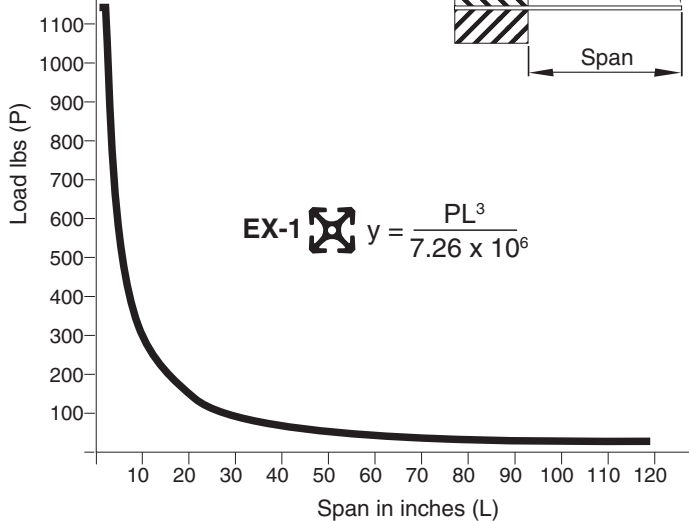
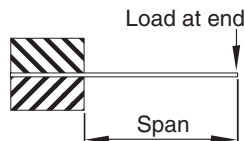

**TECHNICAL**

## EX-2

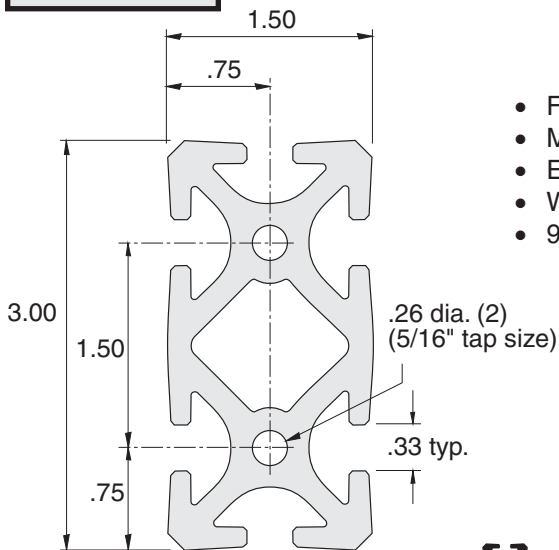

- Finish = Clear anodized
- Material = 6105-T5 Aluminum
- Est. Area = 2.051 Sq. In.
- Weight/ft = 2.471 lbs.
- 96", 144.25", 192.63" Lengths standard.

### Section Properties:

Moment of Intertia in <sup>4</sup>	1.76	.481
Section modulus in <sup>3</sup>	1.173	.641



Load condition:  
Fixed at both ends, load at center  
Deflection = y (inches)

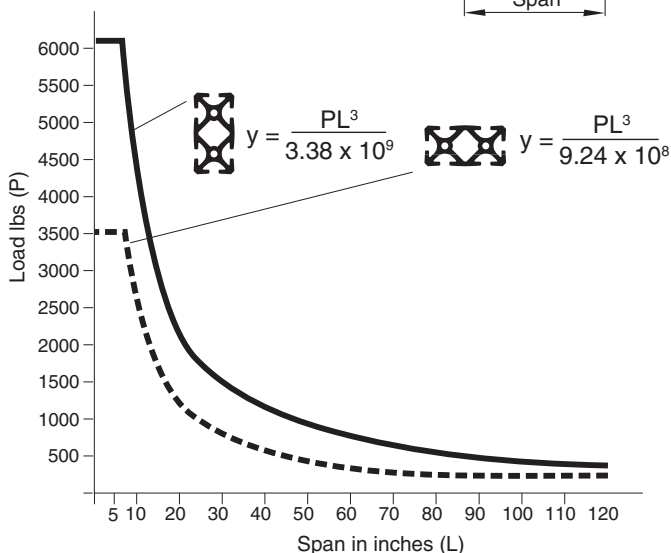
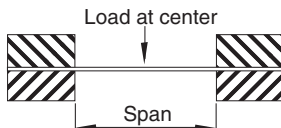

**EX-2**

Load condition:  
Fixed at one end, sliding at one end,  
load at center  
Deflection = Y (inches)

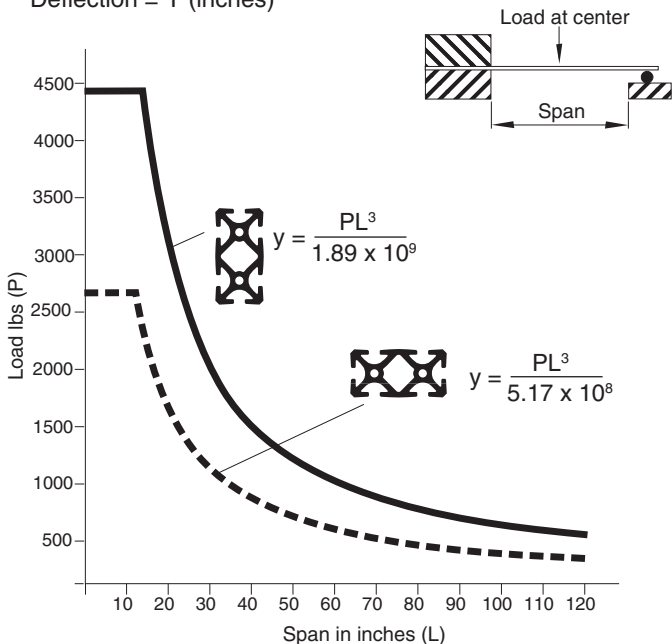

Load condition:  
Fixed at one end,  
load at unsupported end  
Deflection = Y (inches)

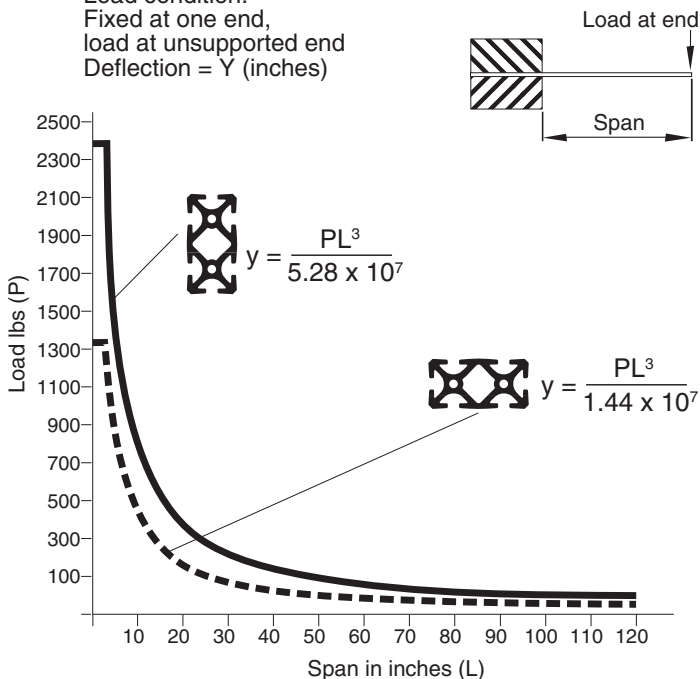

**EX-3**

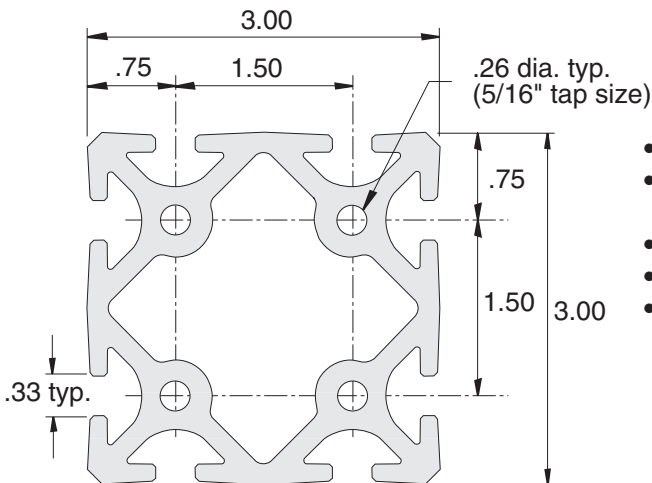

- Finish = Clear anodized
- Material = 6105-T5 Aluminum
- Est. Area = 3.188 Sq. In.
- Weight/ft = 4.037 lbs.
- 96", 144.25", 192.63" Lengths standard.



**Section Properties:**

Moment of Intertia in <sup>4</sup>	3.26
Section modulus in <sup>3</sup>	2.173

Load condition:  
Fixed at both ends, load at center  
Deflection = y (inches)

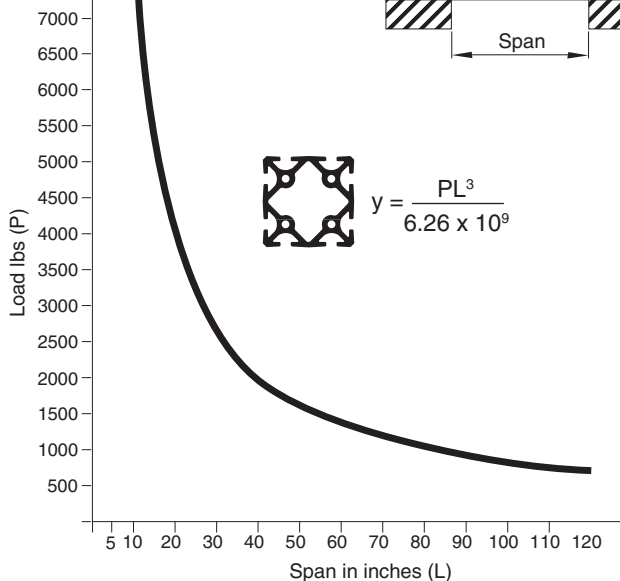
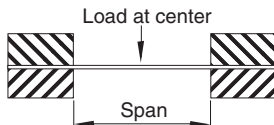

**EX-3**

Load condition:  
Fixed at one end, sliding at one end,  
load at center  
Deflection = Y (inches)

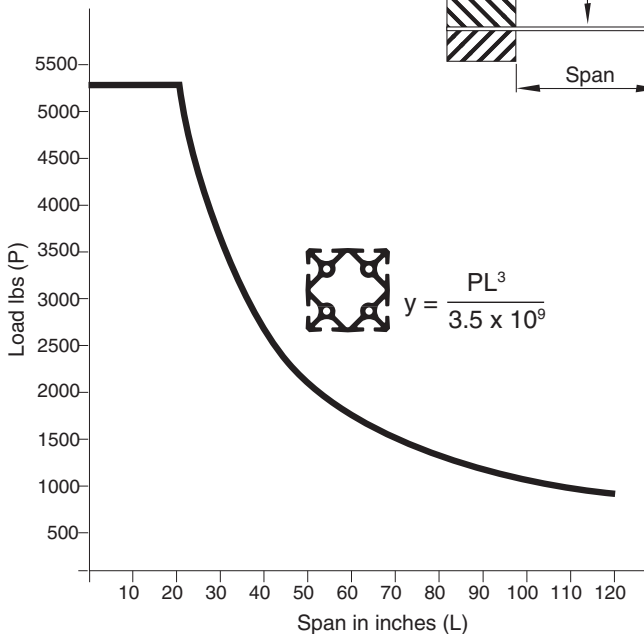

Load condition:  
Fixed at one end,  
load at unsupported end  
Deflection = Y (inches)

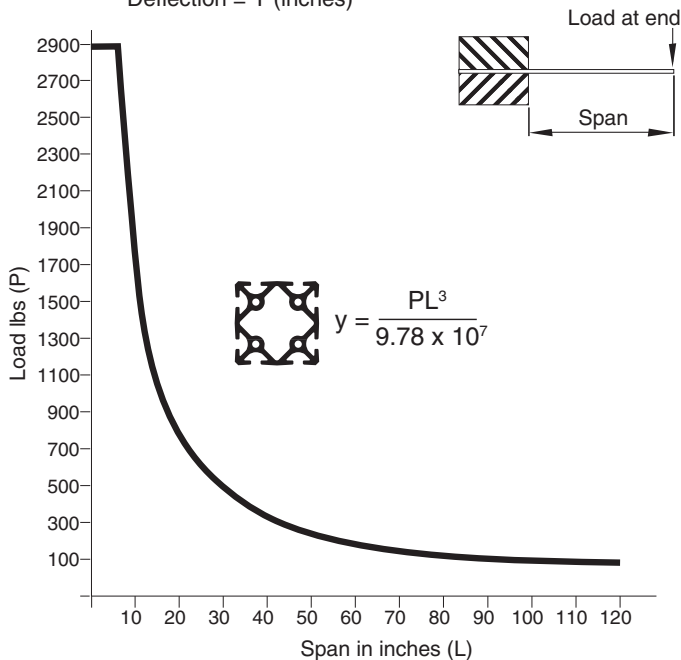



## EX-6

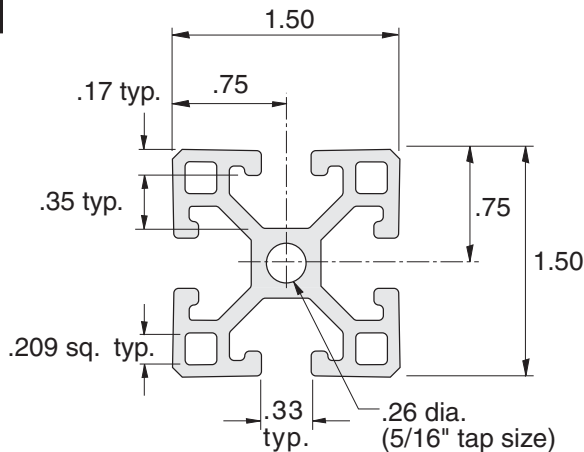

- Finish = Clear anodized
- Material = 6105-T5 Aluminum
- Est. Area = .878 Sq. In.
- Weight/ft = 1.029 lbs.
- 96", 144.25", 192.63" Lengths standard.

### Section Properties:

Moment of Inertia in <sup>4</sup>	.199
Section modulus in <sup>3</sup>	.265

Load condition:  
Fixed at both ends, load at center  
Deflection = y (inches)

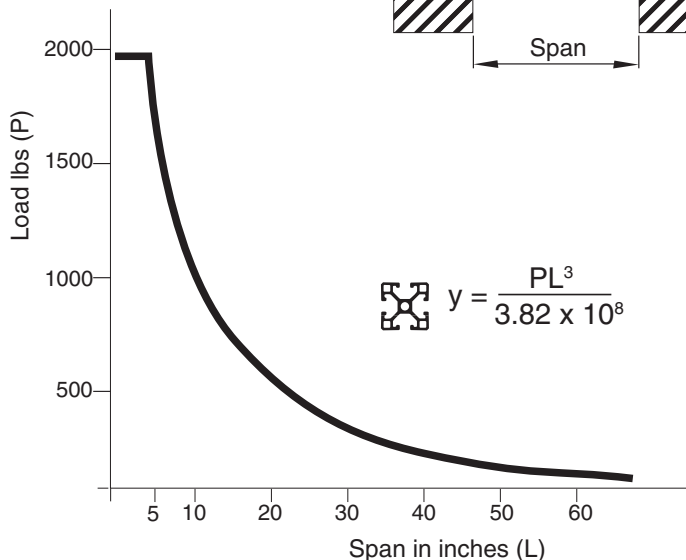
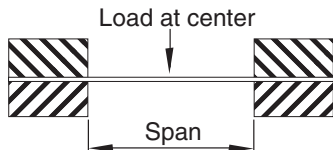

**EX-6**

Load condition:  
Fixed at one end, sliding at one end,  
load at center  
Deflection = Y (inches)

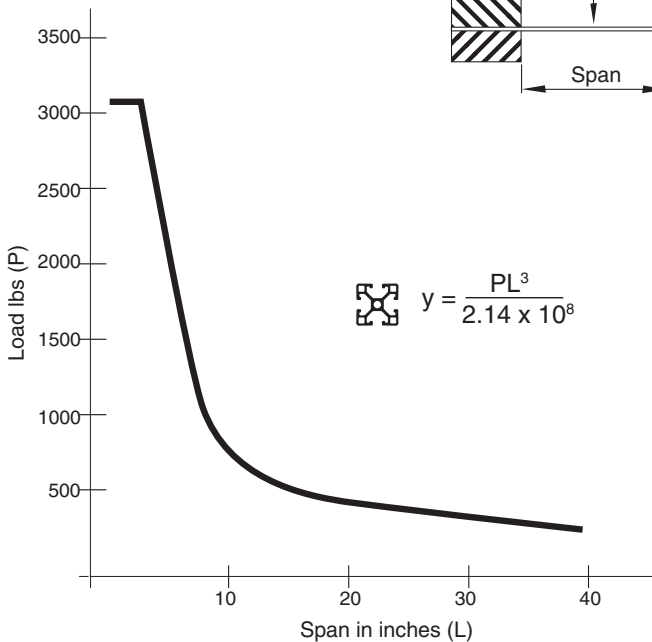
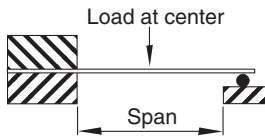

  $y = \frac{PL^3}{2.14 \times 10^8}$

Load condition:  
Fixed at one end,  
load at unsupported end  
Deflection = Y (inches)

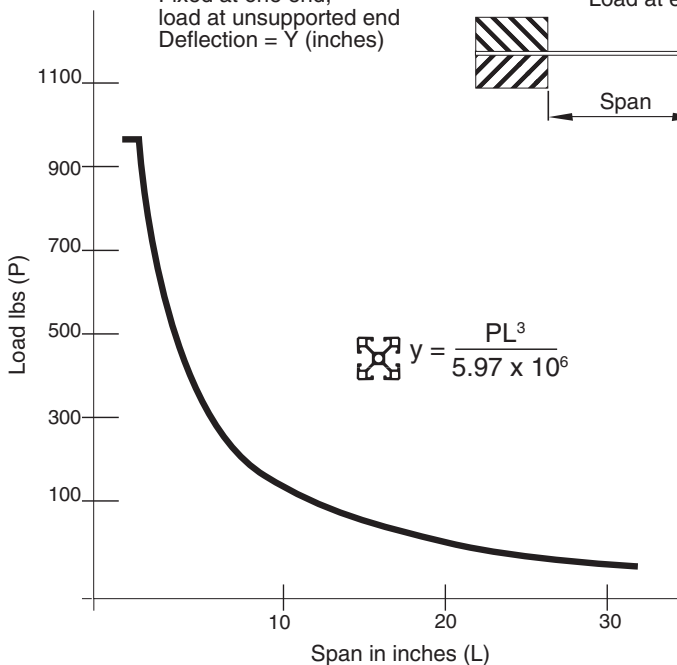
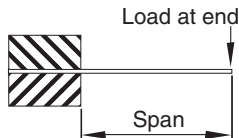

  $y = \frac{PL^3}{5.97 \times 10^6}$

## EX-7

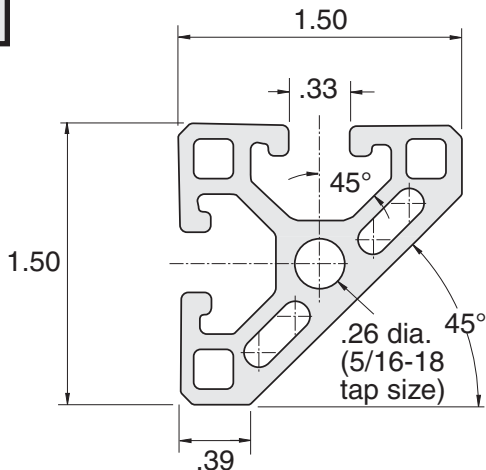

- Finish = Clear anodized
- Material = 6105-T5 Aluminum
- Est. Area = .729 Sq. In.
- Weight/ft = .854 lbs.
- 96", 192.63" Lengths standard.

### Section Properties:

Moment of Intertia in <sup>4</sup>	.137
Section modulus in <sup>3</sup>	.195

Load condition:

Fixed at both ends, load at center

Deflection = y (inches)

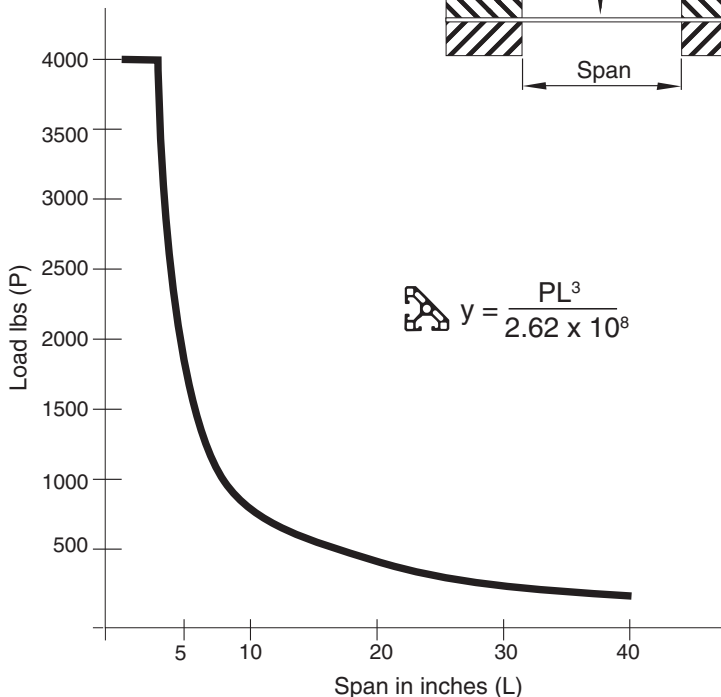
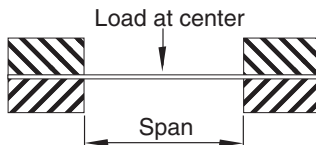

**EX-7**

Load condition:  
Fixed at one end, sliding at one end,  
load at center  
Deflection = Y (inches)

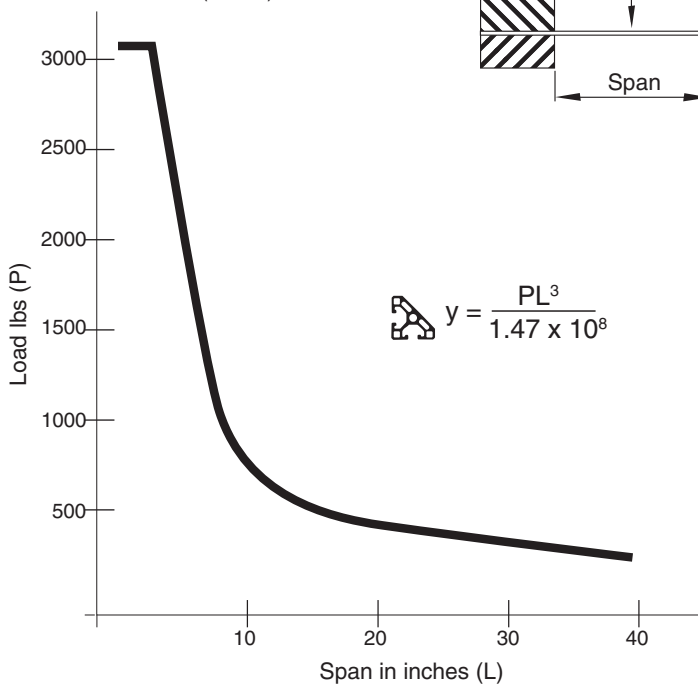

Load condition:  
Fixed at one end,  
load at unsupported end  
Deflection = Y (inches)

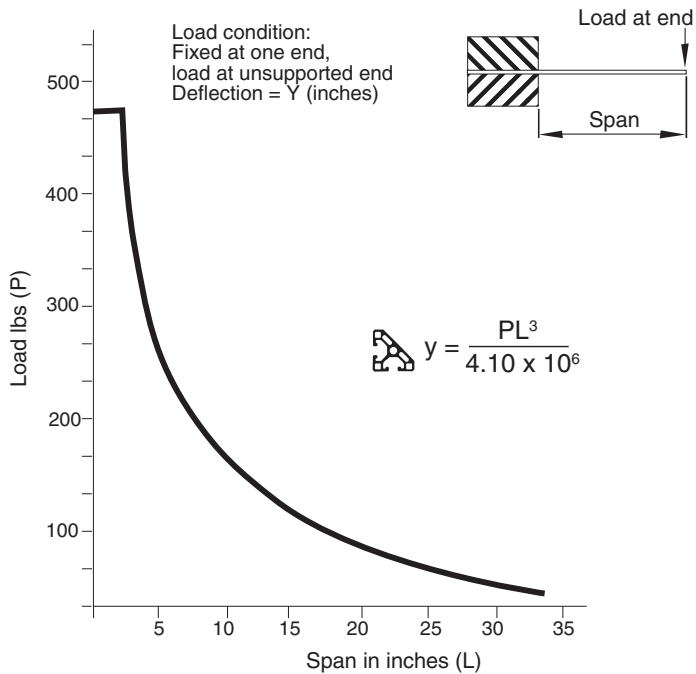

## EX-8

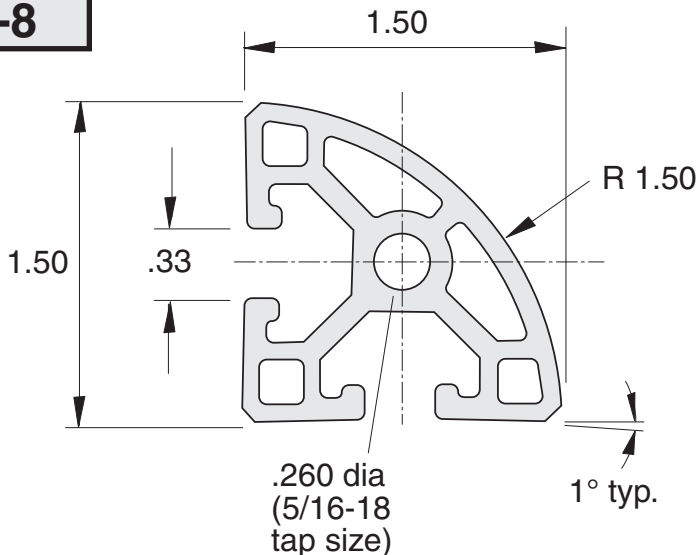

- Finish = Clear anodized
- Material = 6105-T6 Aluminum
- Est. Area = .803 Sq. In.
- Weight/ft = .945 lbs.
- 96", 192.63" Lengths standard.

### Section Properties:

Moment of Intertia in <sup>4</sup>	.156
Section modulus in <sup>3</sup>	.188

Load condition:  
Fixed at both ends, load at center  
Deflection = y (inches)

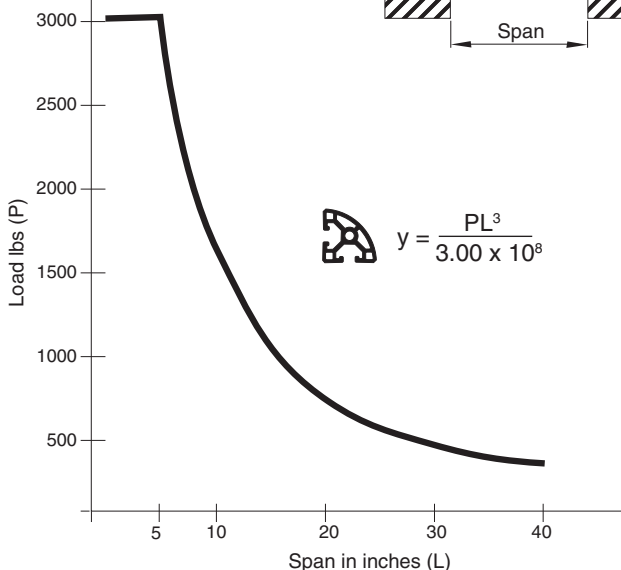
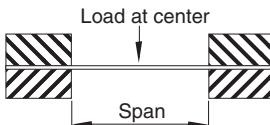

## EX-8

Load condition:  
Fixed at one end, sliding at one end,  
load at center  
Deflection = Y (inches)

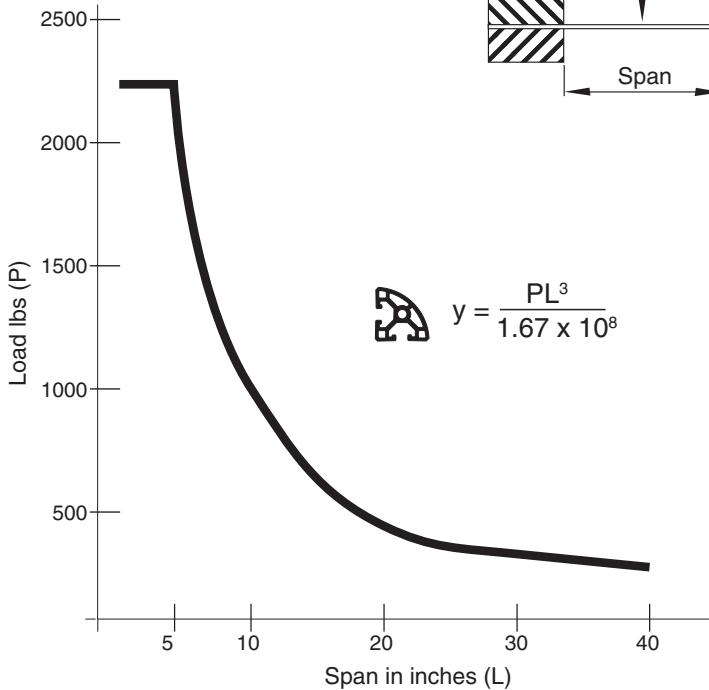
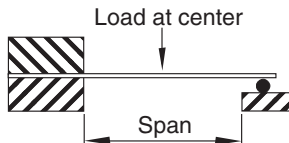

$$y = \frac{PL^3}{1.67 \times 10^8}$$

Load condition:  
Fixed at one end,  
load at unsupported end  
Deflection = Y (inches)

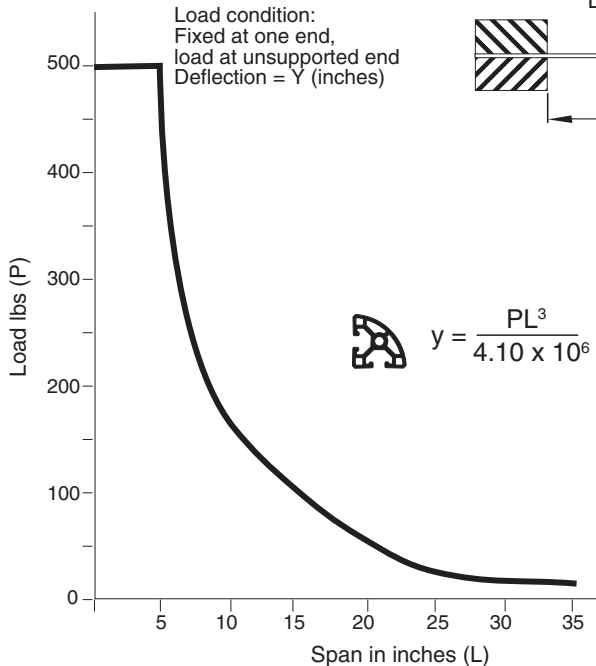
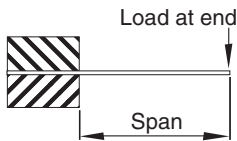

$$y = \frac{PL^3}{4.10 \times 10^6}$$

# 45 Degree Light Extrusion



## EX-82

- 5/16" Slot Size
- Weight/Ft = 1.02 lbs.
- Est. Area = .85 Sq. In.
- Finish = Clear Anodized
- Material = 6105-T5 Aluminum
- 96", 192.63" Standard Lengths

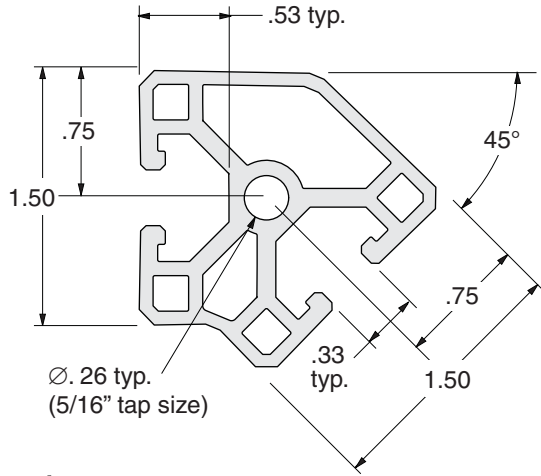

### Section Properties:

Moment of Intertia in <sup>4</sup>	0.1872	0.1854
Section modulus in <sup>3</sup>	0.2035	0.1817



Load condition:  
Fixed at both ends, load at center  
Deflection = y (inches)

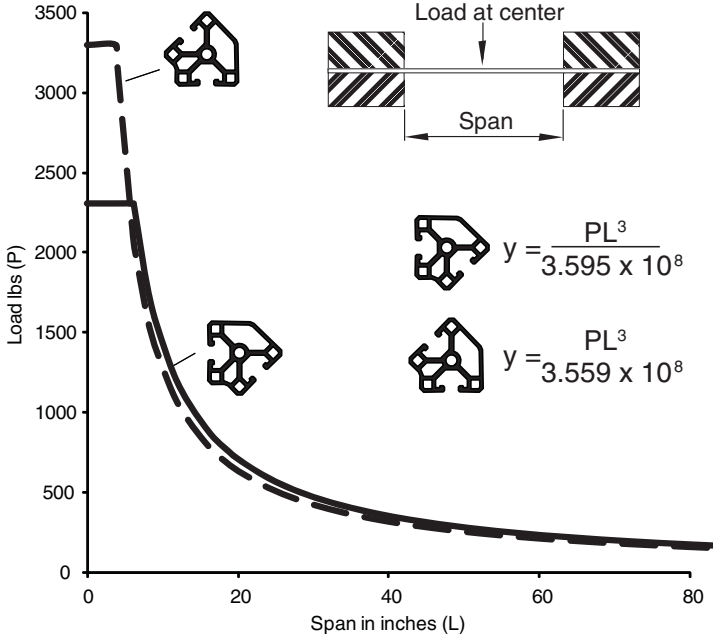

TECHNICAL

**EX-82**

Load condition:  
Fixed at one end, sliding at one end,  
load at center  
Deflection = Y (inches)

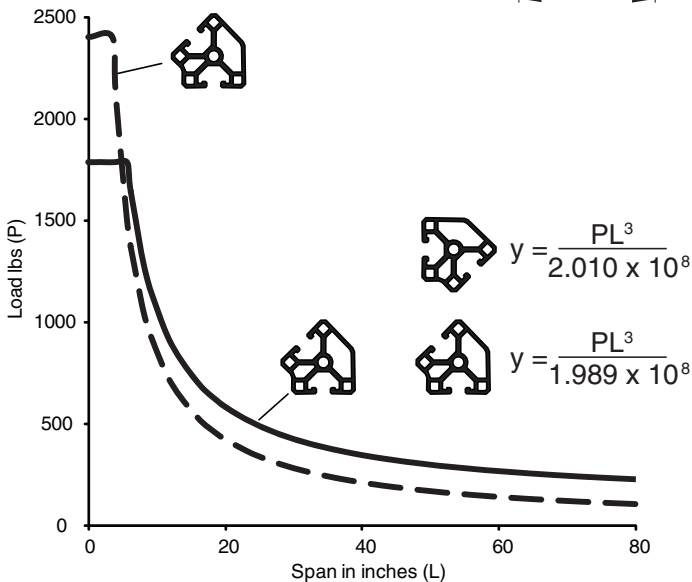
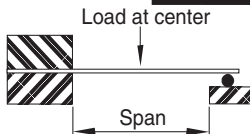

Load condition:  
Fixed at one end,  
load at unsupported end  
Deflection = Y (inches)

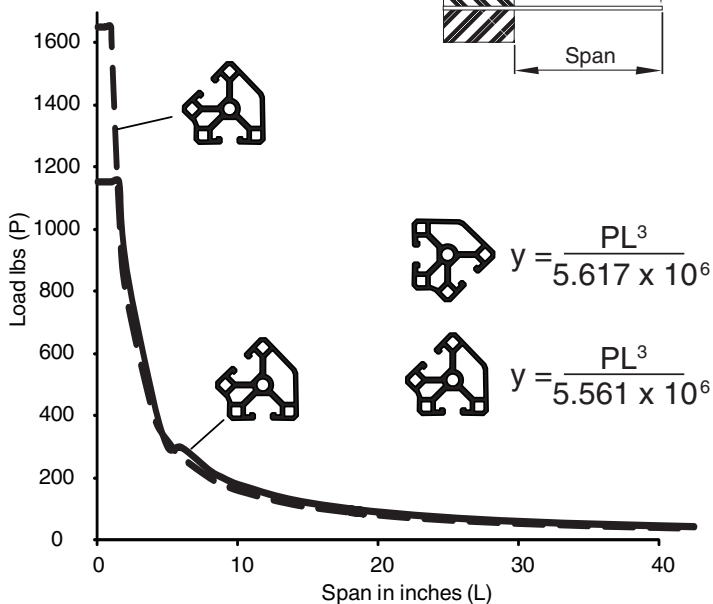
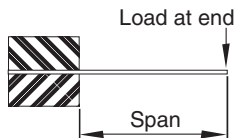



# 1.5" x 1.5" Ultra-Light Extrusion



## EX-9

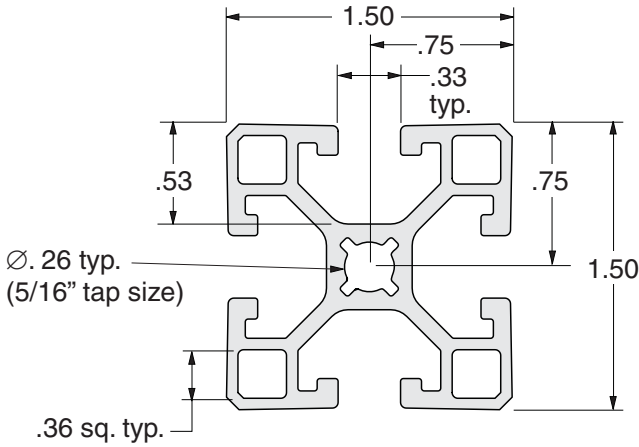

- 5/16" Slot Size
- Weight/Ft = .85 lbs.
- Est. Area = .73 Sq. In.
- Finish = Clear Anodized
- Material = 6105-T5 Aluminum
- 96", 192.63" Standard Lengths

### Section Properties:

Moment of Inertia in <sup>4</sup>	.1623
Section modulus in <sup>3</sup>	.2164

Load condition:  
Fixed at both ends, load at center  
Deflection = y (inches)

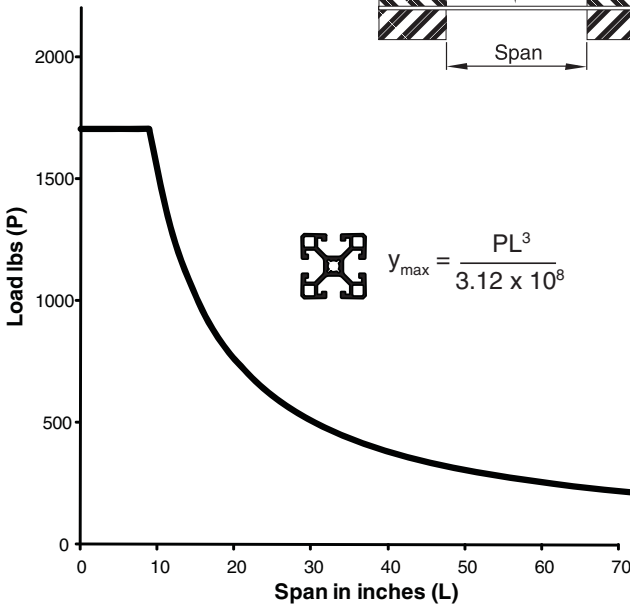
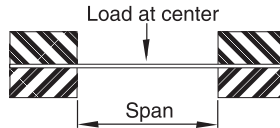

TECHNICAL

**EX-9**

Load condition:  
Fixed at one end, sliding at one end,  
load at center  
Deflection = Y (inches)

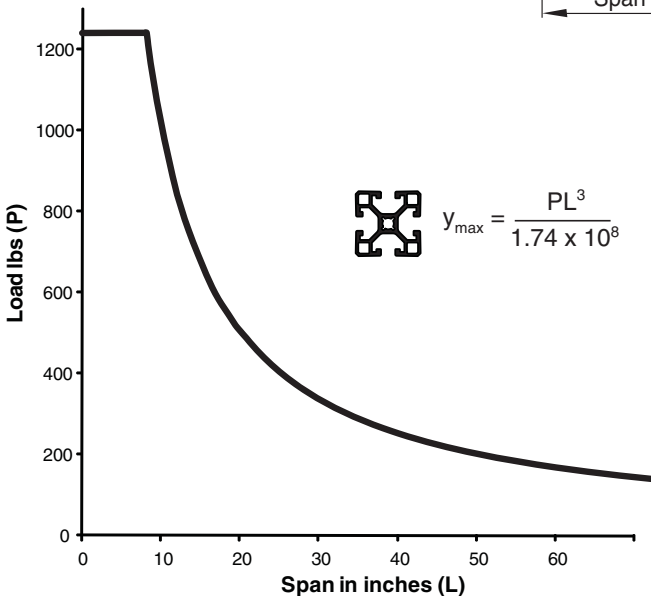
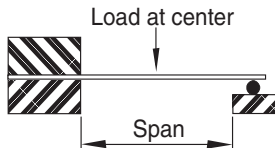

Load condition:  
Fixed at one end,  
load at unsupported end  
Deflection = Y (inches)

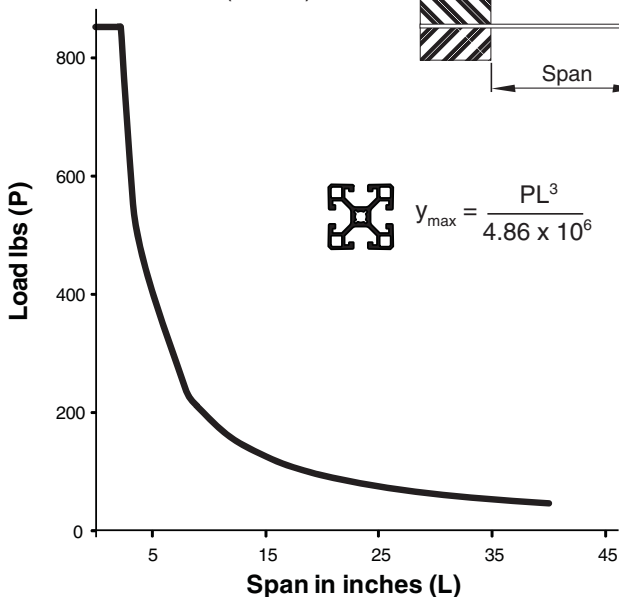
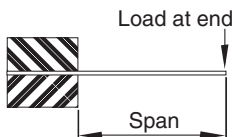

## EX-26

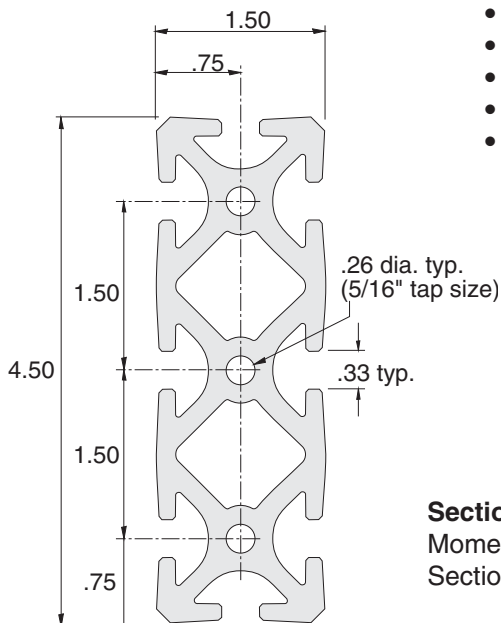

- Finish = Clear anodized
- Material = 6105-T5 Aluminum
- Est. Area = 3.02 Sq. In.
- Weight/ft = 3.552 lbs.
- 96", 192.63" Lengths standard.

### Section Properties:

Moment of Inertia in <sup>4</sup>	5.6781	.6911
Section modulus in <sup>3</sup>	2.5236	.9215



Load condition:  
Fixed at both ends, load at center  
Deflection = y (inches)

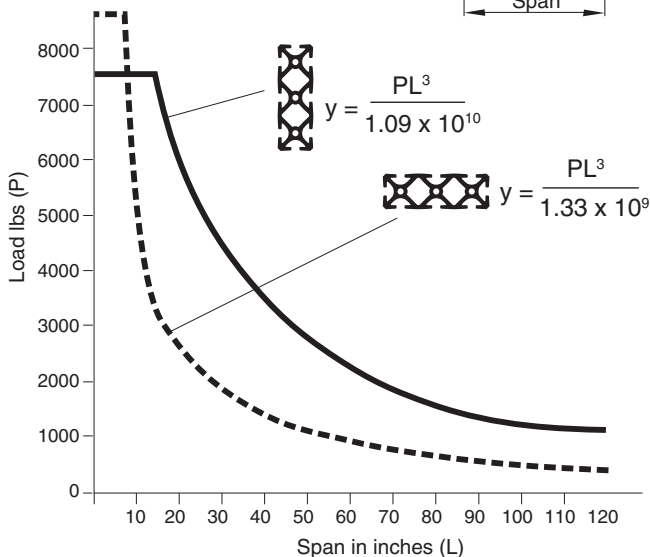
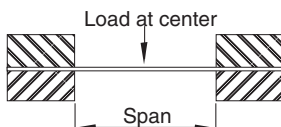

**EX-26**

Load condition:  
Fixed at one end, sliding at one end,  
load at center  
Deflection = Y (inches)

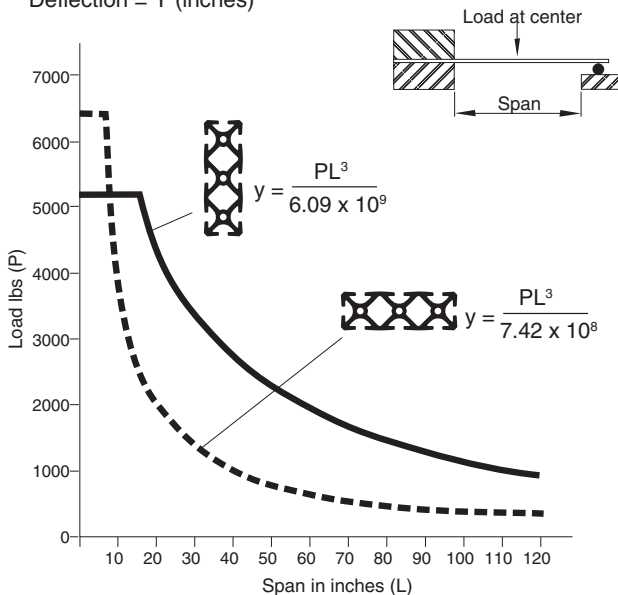

Load condition:  
Fixed at one end,  
load at unsupported end  
Deflection = Y (inches)

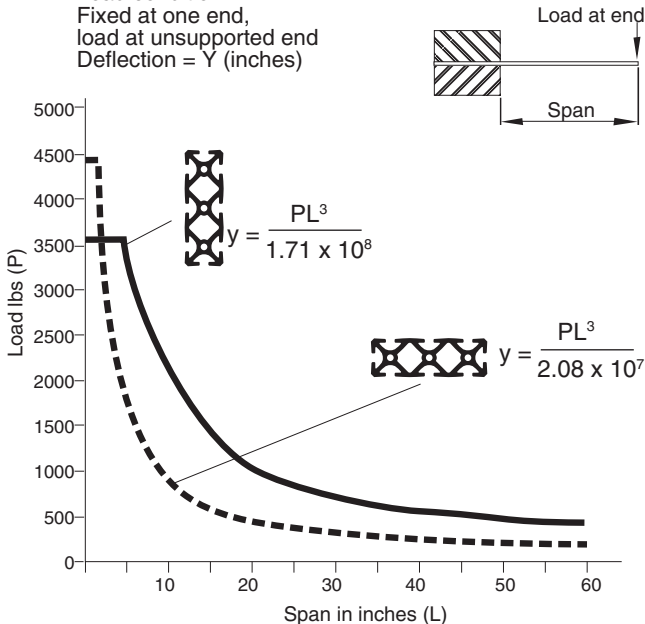

## EX-36

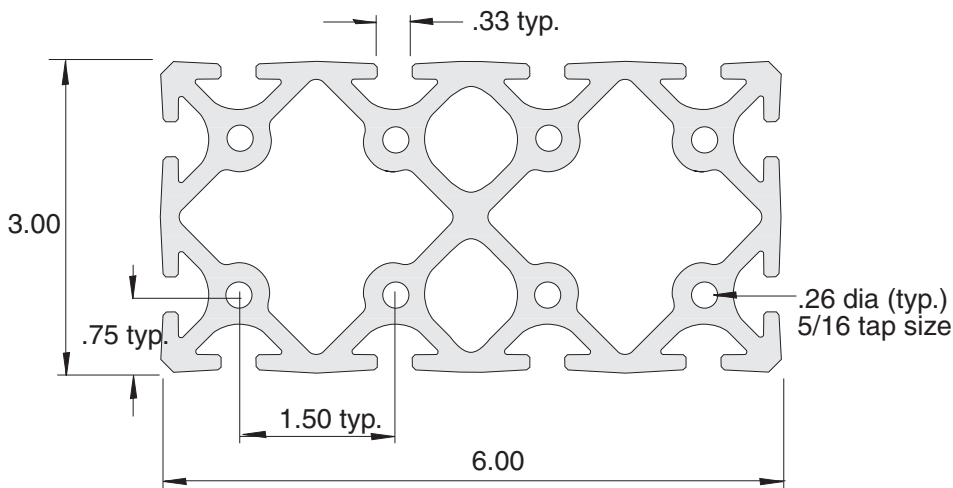

- Finish = Clear anodized
- Material = 6063-T6 Aluminum
- Est. Area = 5.924 Sq. In.
- Weight/ft = 6.967 lbs.
- 96", 192.63" Lengths standard.

### Section Properties:

Moment of Inertia in <sup>4</sup>	22.05	6.41
Section modulus in <sup>3</sup>	7.35	4.28

Load condition:  
Fixed at both ends, load at center  
Deflection = y (inches)

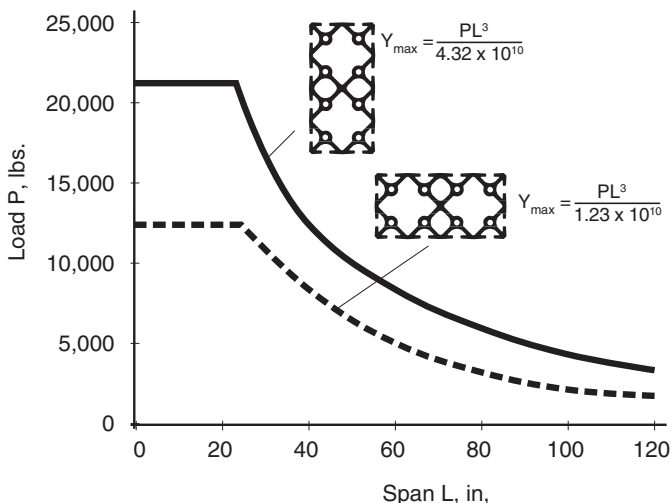
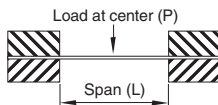

Load condition:  
Fixed at one end, sliding at one end,  
load at center  
Deflection = Y (inches)

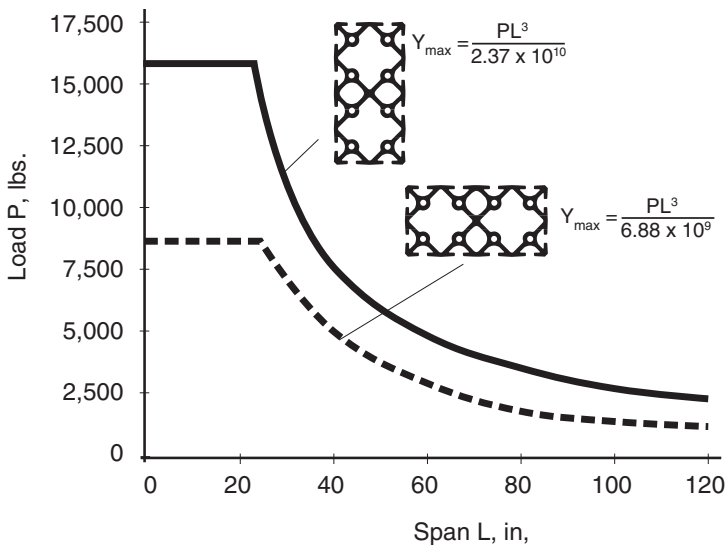
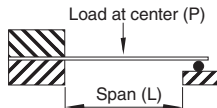

Load condition:  
Fixed at one end,  
load at unsupported end  
Deflection = Y (inches)

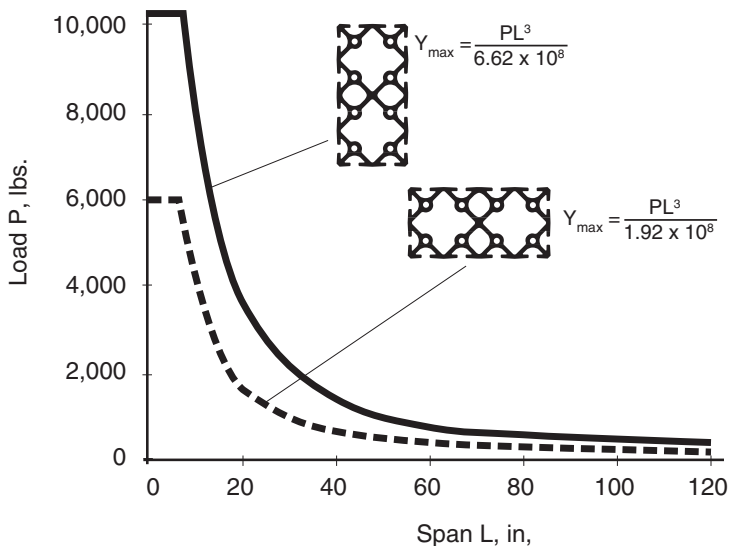
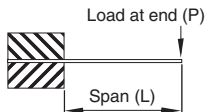

# 3" x 3" Light Extrusion



## EX-37

- 5/16" Slot Size
- Weight/Ft = 2.81 lbs.
- Est. Area = 2.35 Sq. In.
- Finish = Clear Anodized
- Material = 6105-T5 Aluminum
- 96", 192.63" Standard Lengths

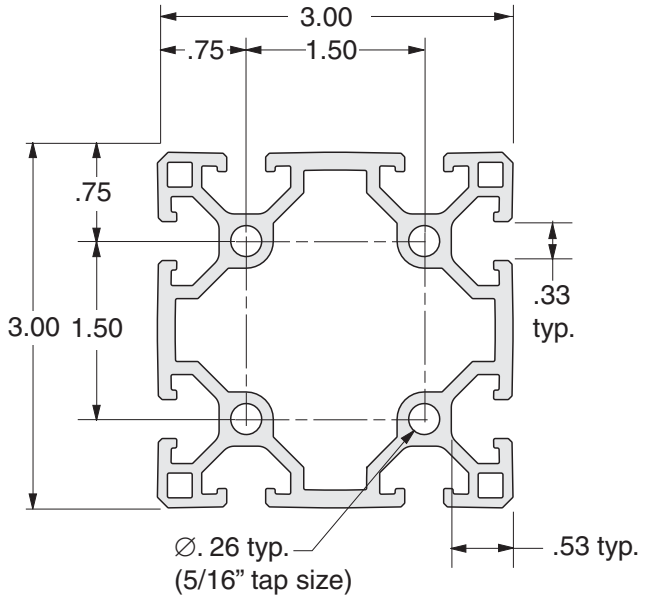

### Section Properties:

Moment of Intertia in <sup>4</sup>	2.44
Section modulus in <sup>3</sup>	1.63

Load condition:  
 Fixed at both ends, load at center  
 Deflection = y (inches)

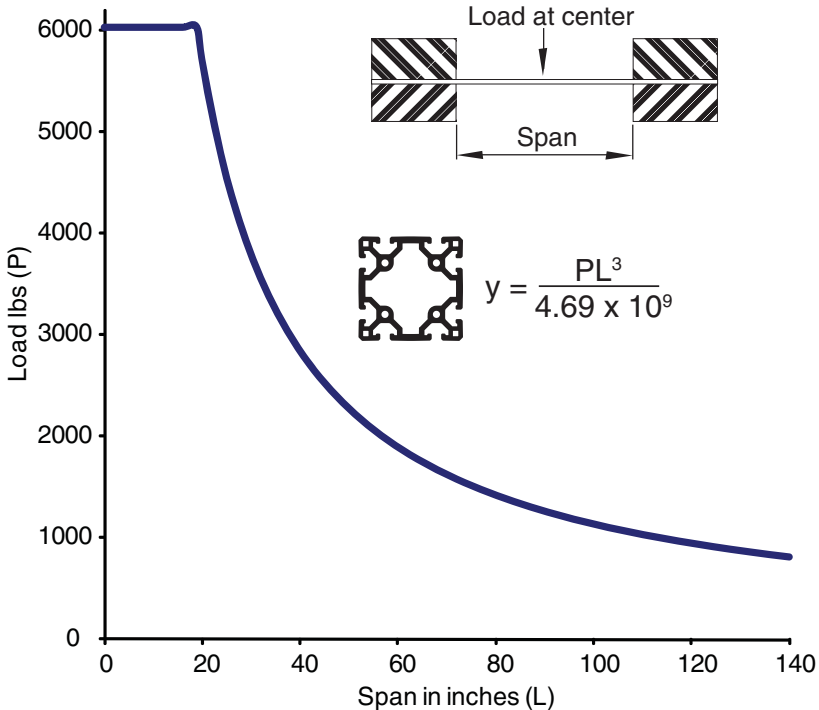

TECHNICAL

**EX-37**

Load condition:  
Fixed at one end, sliding at one end,  
load at center  
Deflection = Y (inches)

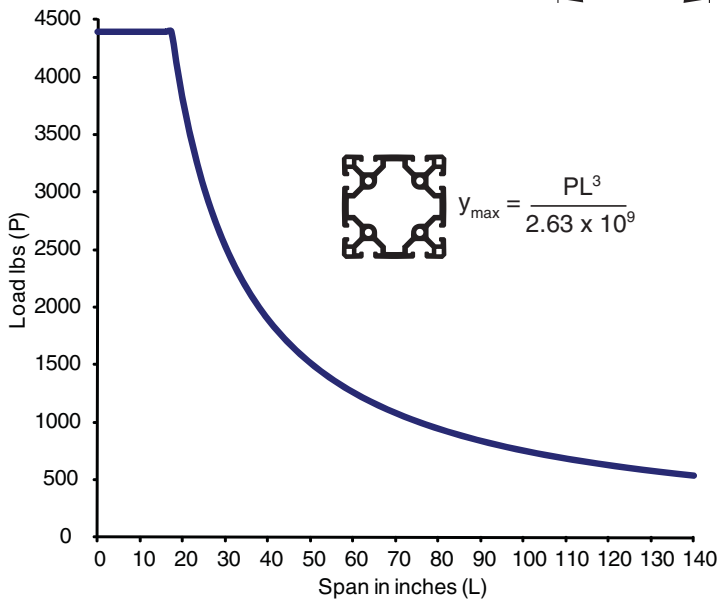
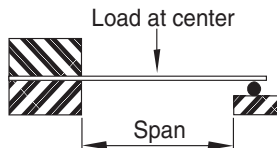

Load condition:  
Fixed at one end,  
load at unsupported end  
Deflection = Y (inches)

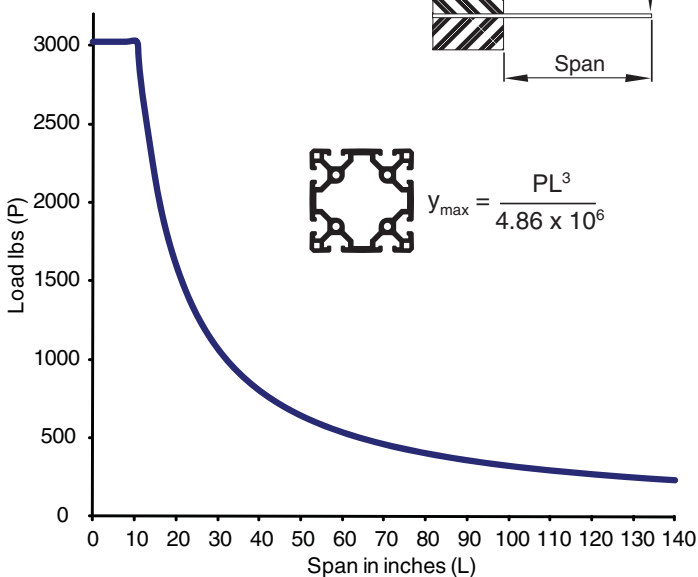
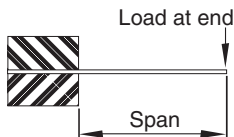

**TECHNICAL**



## EX-52

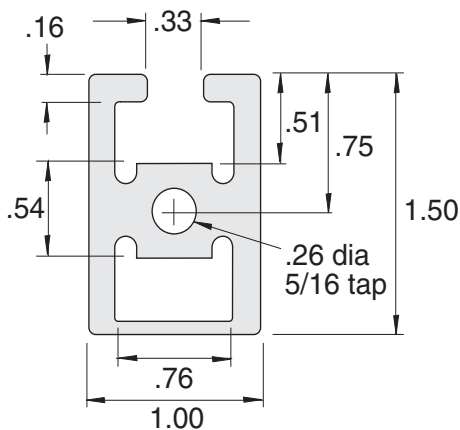

- Finish = Clear anodized
- Material = 6105-T5 Aluminum
- Est. Area = .818 Sq. In.
- Weight/ft = .954 lbs.
- 96", 192.63" Lengths standard.



### Section Properties:

Moment of Intertia in <sup>4</sup>	0.417	0.099
Section modulus in <sup>3</sup>	0.549	0.198

Load condition:  
Fixed at both ends, load at center  
Deflection = y (inches)

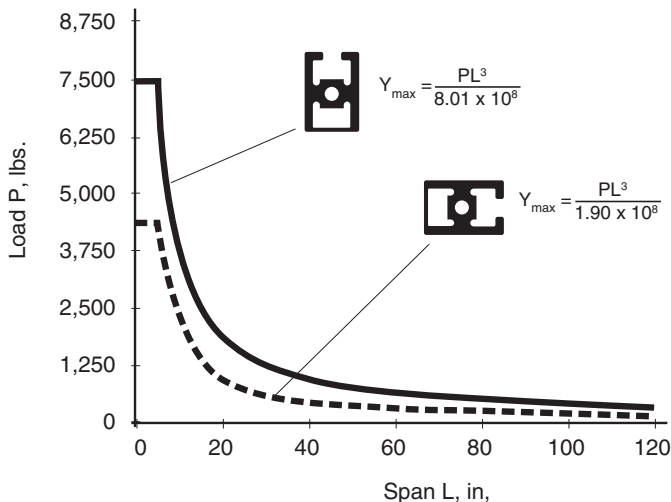
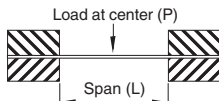

Load condition:  
Fixed at one end, sliding at one end,  
load at center  
Deflection = Y (inches)

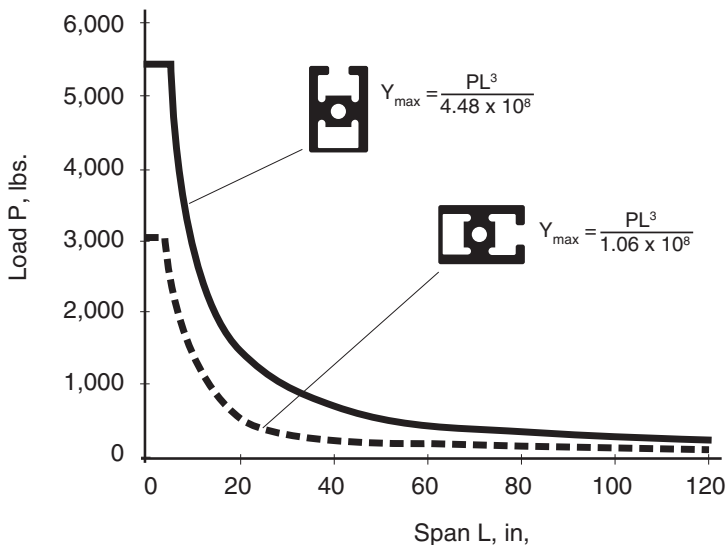
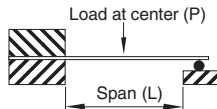

Load condition:  
Fixed at one end,  
load at unsupported end  
Deflection = Y (inches)

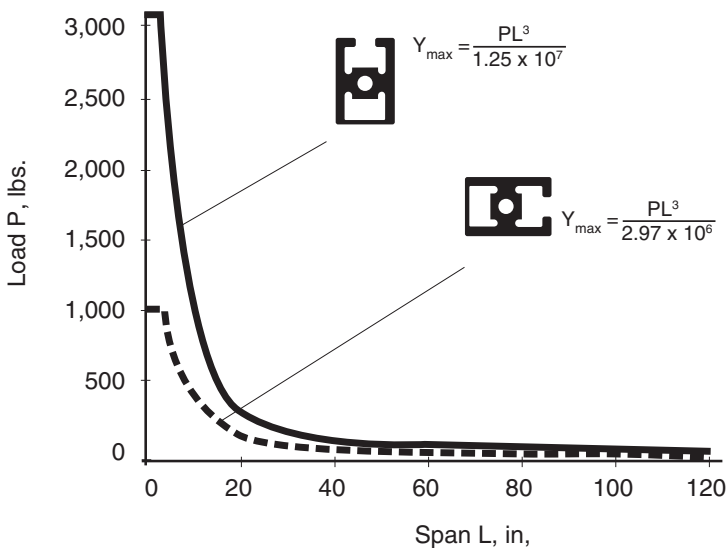
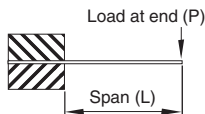

## EX-54

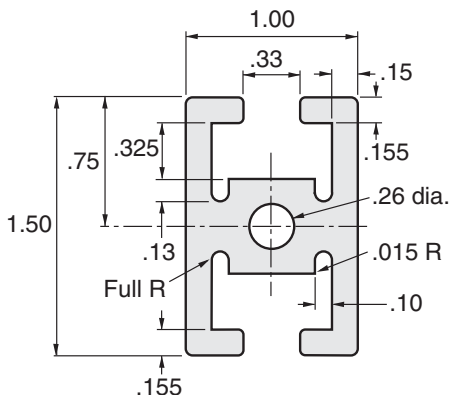

- Finish = Clear anodized
- Material = 6105-T5 Aluminum
- Est. Area = .840 Sq. In.
- Weight/ft = 1.008 lbs.
- 96", 192.63" Lengths standard.



### Section Properties:

Moment of Intertia in <sup>4</sup>	0.142	0.100
Section modulus in <sup>3</sup>	0.189	0.200

Load condition:  
Fixed at both ends, load at center  
Deflection = y (inches)

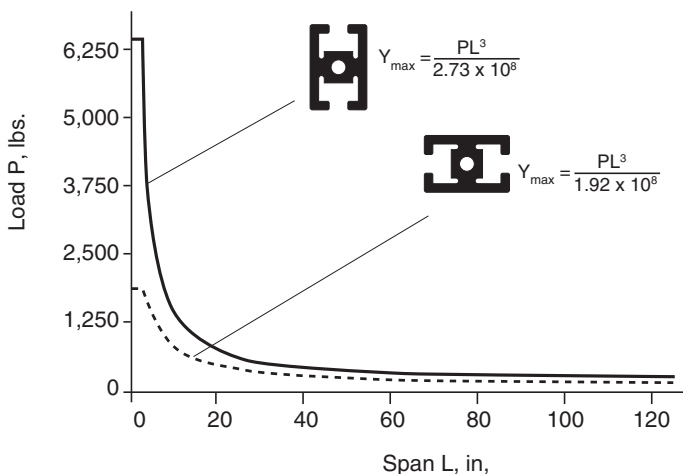
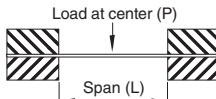

Load condition:  
Fixed at one end, sliding at one end,  
load at center  
Deflection = Y (inches)

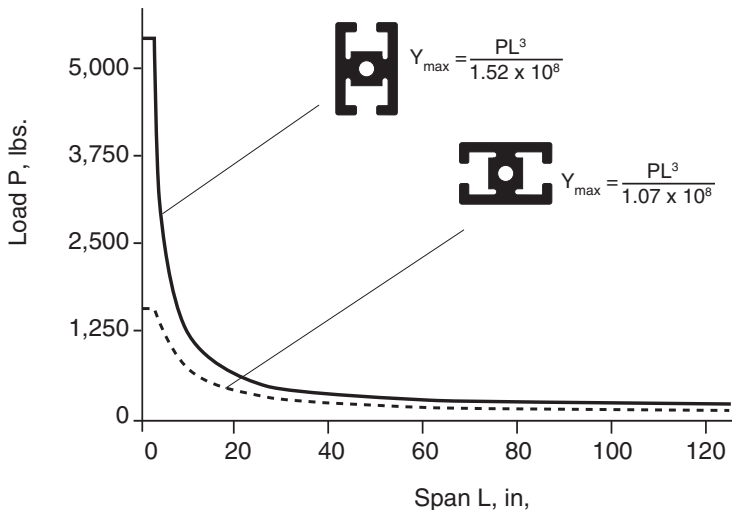
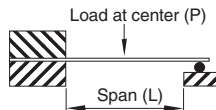

Load condition:  
Fixed at one end,  
load at unsupported end  
Deflection = Y (inches)

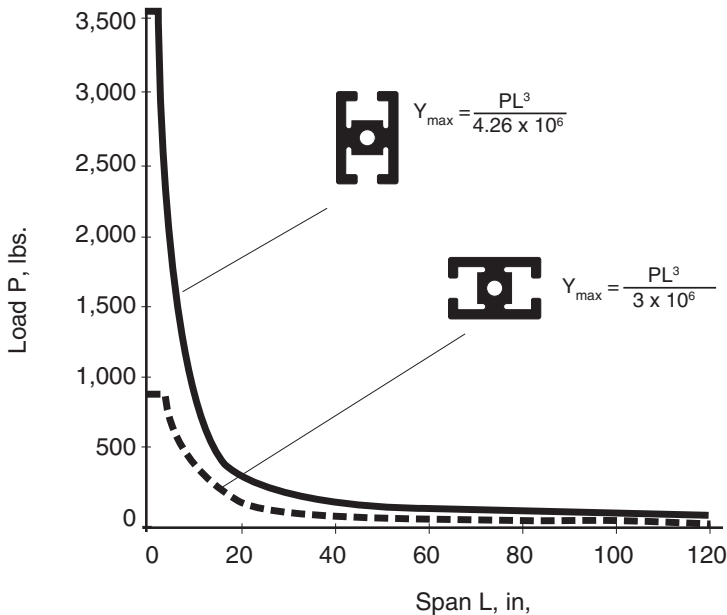
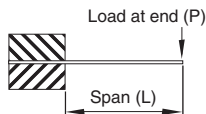

## EX-60

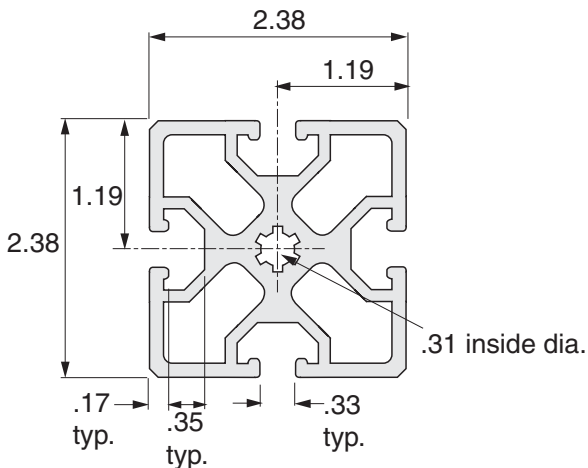

- Finish = Clear anodized
- Material = 6105-T6 Aluminum
- Est. Area = 2.041 Sq. In.
- Weight/ft = 2.400 lbs
- 96", 192.63" Lengths standard.

### Section Properties:

Moment of Inertia in<sup>4</sup> 1.0211  
 Section modulus in<sup>3</sup> 0.860

Load condition:  
 Fixed at both ends, load at center  
 Deflection = y (inches)

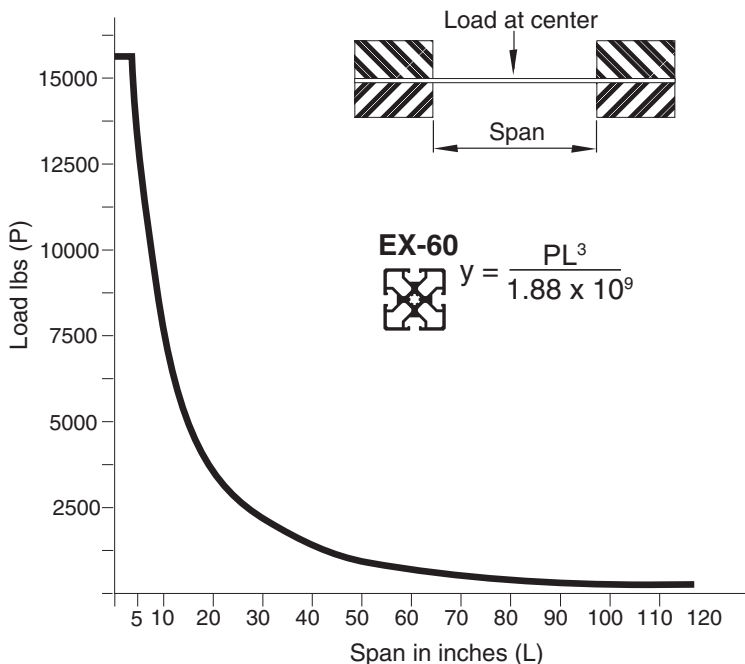

**EX-60**

Load condition:  
Fixed at one end, sliding at one end,  
load at center  
Deflection = Y (inches)

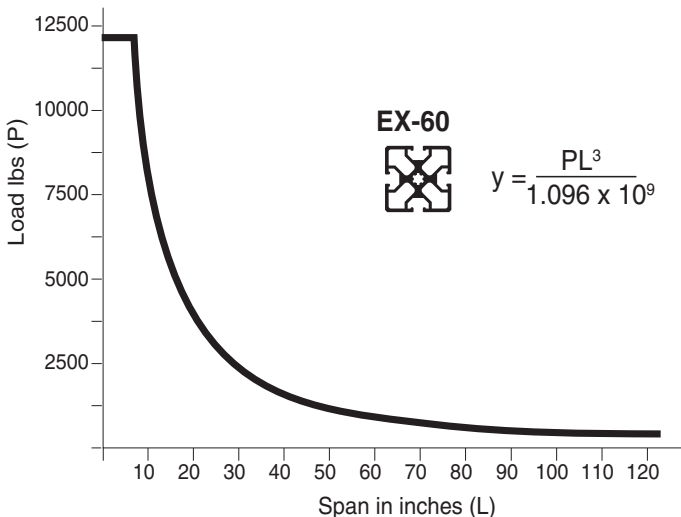
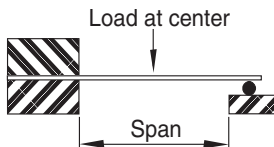

Load condition:  
Fixed at one end,  
load at unsupported end  
Deflection = Y (inches)

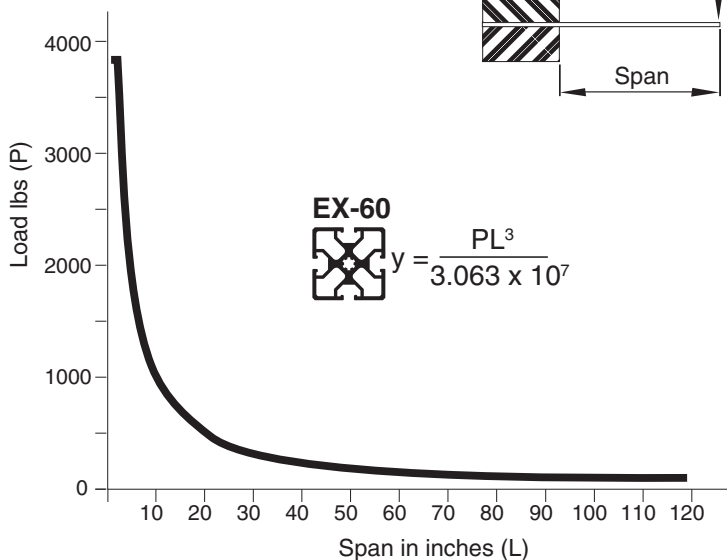
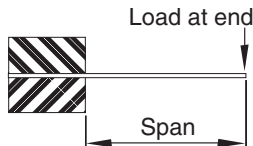

**TECHNICAL**

## EX-61

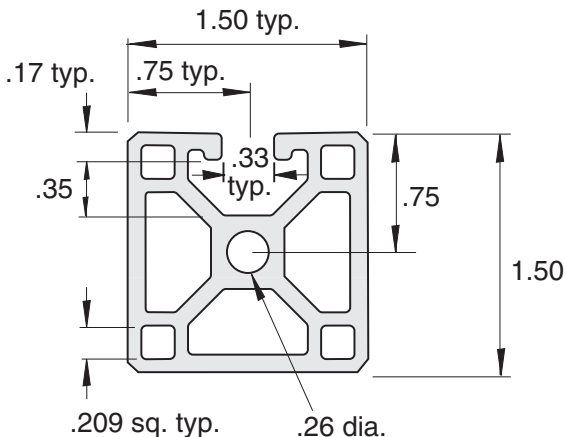

- Finish = Clear anodized
- Material = 6105-T5 Aluminum
- Est. Area = .866 Sq. In.
- Weight/ft = 1.018 lbs
- 96", 192.63" Lengths standard.

### Section Properties:

Moment of Intertia in<sup>4</sup>  
Section modulus in<sup>3</sup>



0.200	0.210
0.267	0.276

Load condition:  
Fixed at both ends, load at center  
Deflection = y (inches)

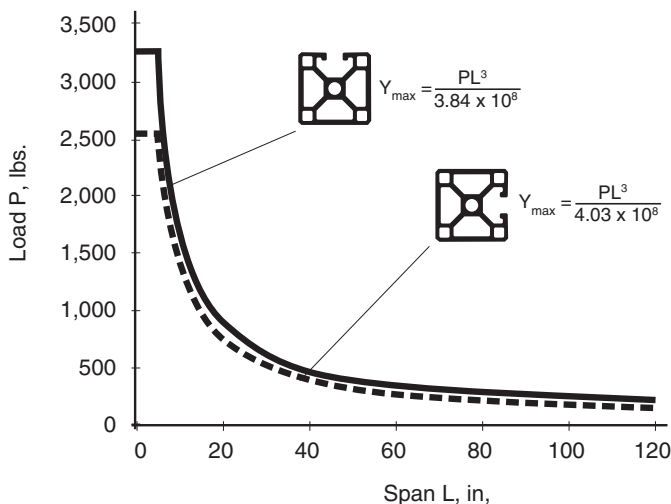
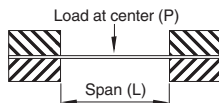

## EX-61

Load condition:  
Fixed at one end, sliding at one end,  
load at center  
Deflection = Y (inches)

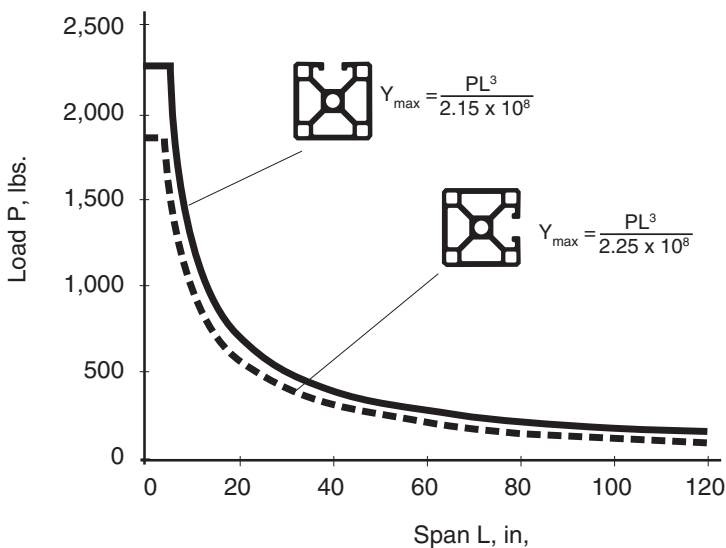
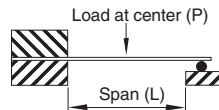

Load condition:  
Fixed at one end,  
load at unsupported end  
Deflection = Y (inches)

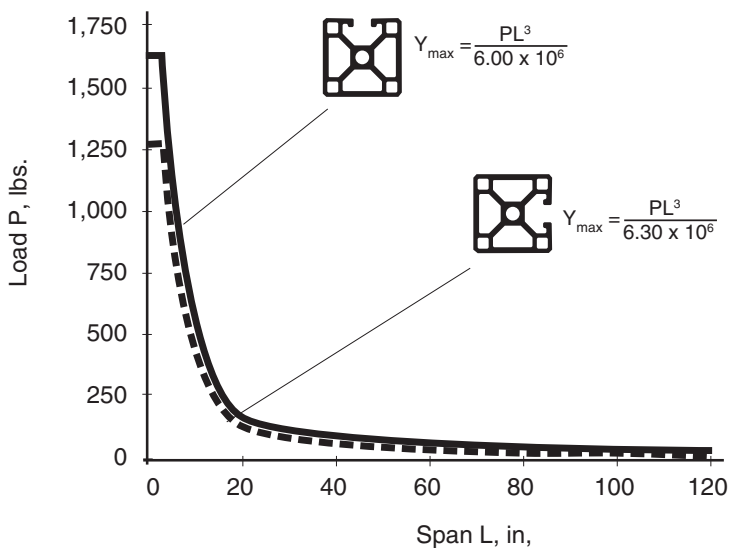
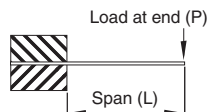



## EX-63

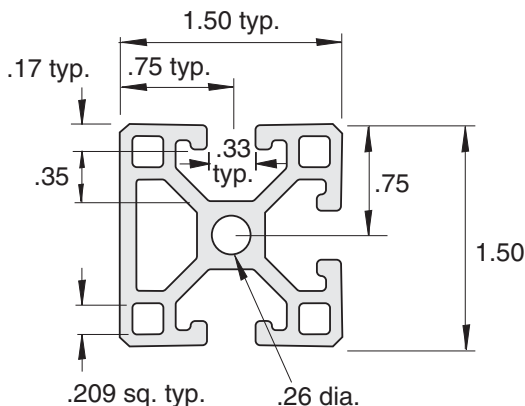

- Finish = Clear anodized
- Material = 6105-T5 Aluminum
- Est. Area = .833 Sq. In.
- Weight/ft = .980 lbs.
- 96", 192.63" Lengths standard.

### Section Properties:

Moment of Intertia in <sup>4</sup>	0.195	0.203
Section modulus in <sup>3</sup>	0.260	0.267



Load condition:  
Fixed at both ends, load at center  
Deflection = y (inches)

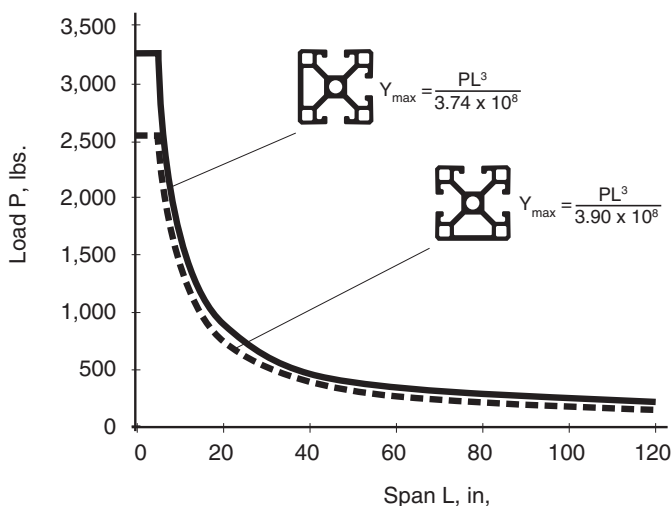
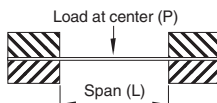

Load condition:  
Fixed at one end, sliding at one end,  
load at center  
Deflection = Y (inches)

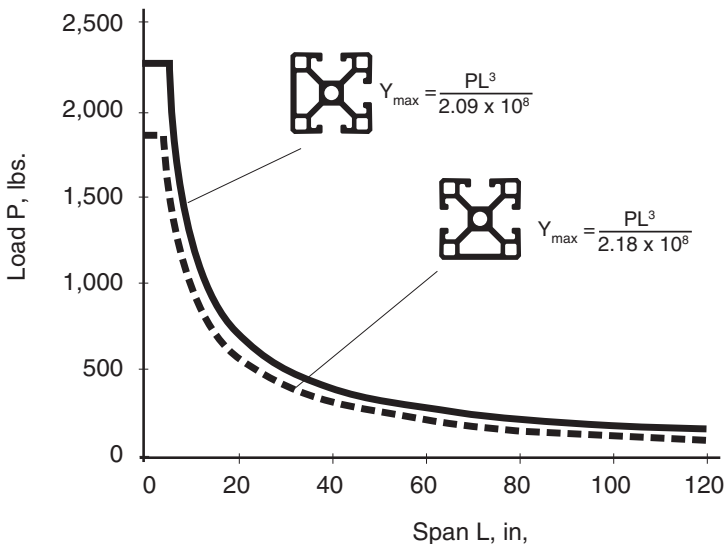
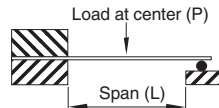

Load condition:  
Fixed at one end,  
load at unsupported end  
Deflection = Y (inches)

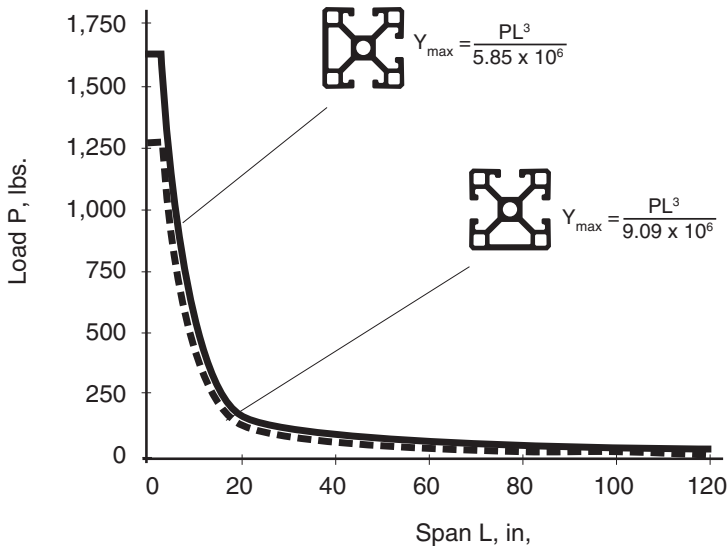
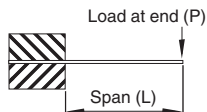

**TECHNICAL**

## EX-64

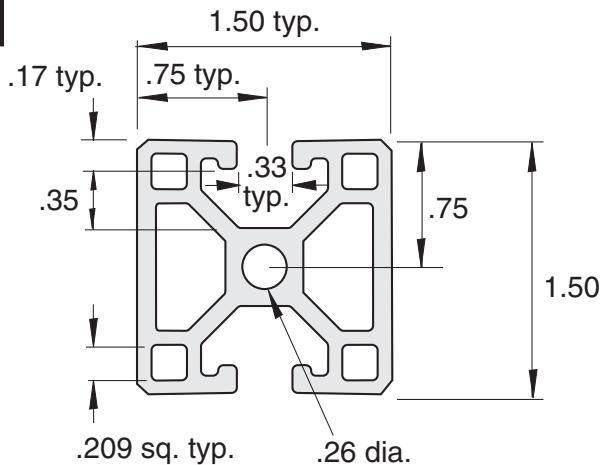

- Finish = Clear anodized
- Material = 6105-T5 Aluminum
- Est. Area = .849 Sq. In.
- Weight/ft = .998 lbs
- 96", 192.63" Lengths standard.

### Section Properties:

Moment of Intertia in<sup>4</sup>  
Section modulus in<sup>3</sup>



0.190  
0.253



0.210  
0.280

Load condition:  
Fixed at both ends, load at center  
Deflection = y (inches)

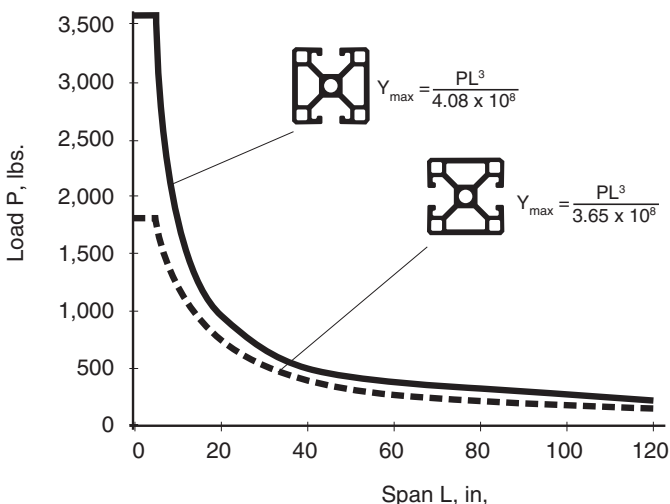
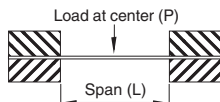

Load condition:  
Fixed at one end, sliding at one end,  
load at center  
Deflection = Y (inches)

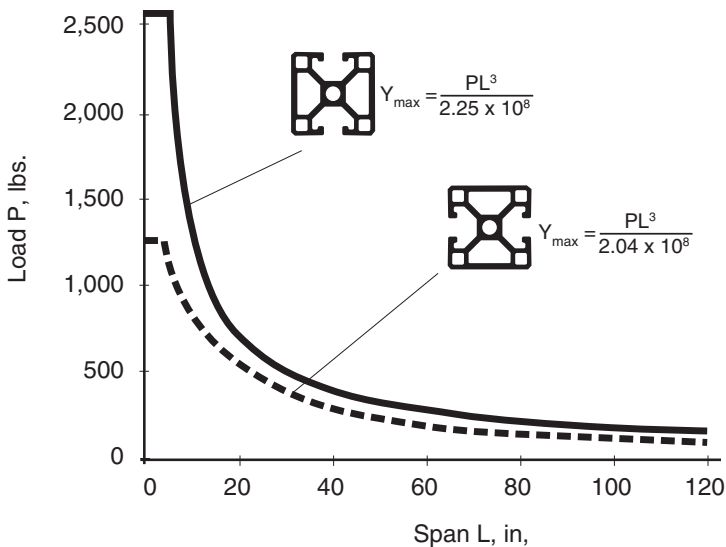
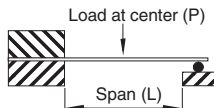

Load condition:  
Fixed at one end,  
load at unsupported end  
Deflection = Y (inches)

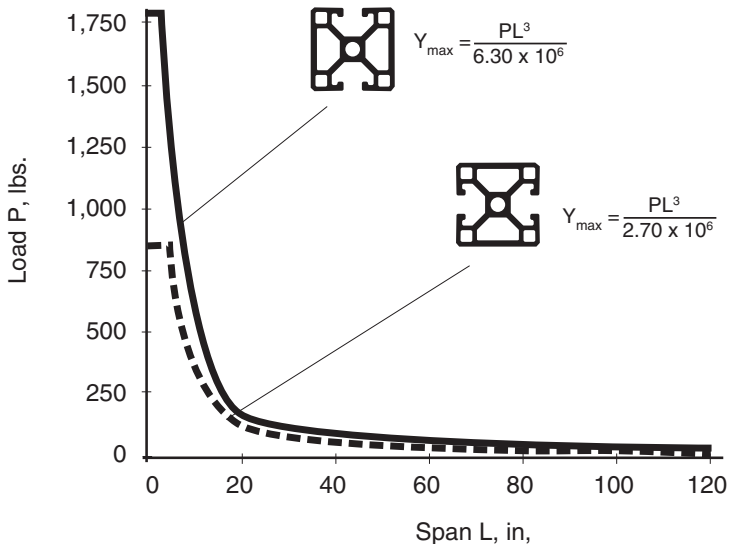
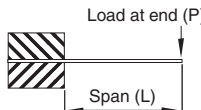

## EX-65

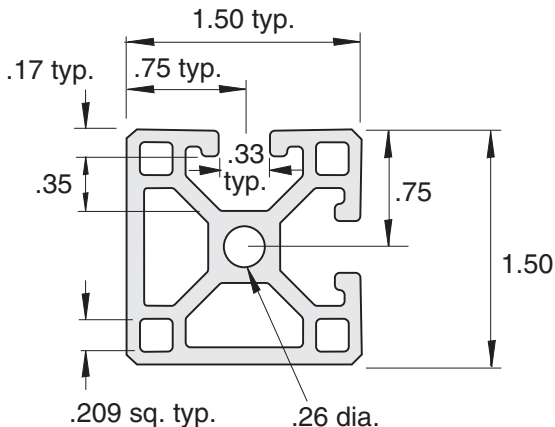

- Finish = Clear anodized
- Material = 6105-T5 Aluminum
- Est. Area = .849 Sq. In.
- Weight/ft = .998 lbs.
- 96", 192.63" Lengths standard.

### Section Properties:



Moment of Inertia in<sup>4</sup> 0.200  
 Section modulus in<sup>3</sup> 0.267

Load condition:  
 Fixed at both ends, load at center  
 Deflection = y (inches)

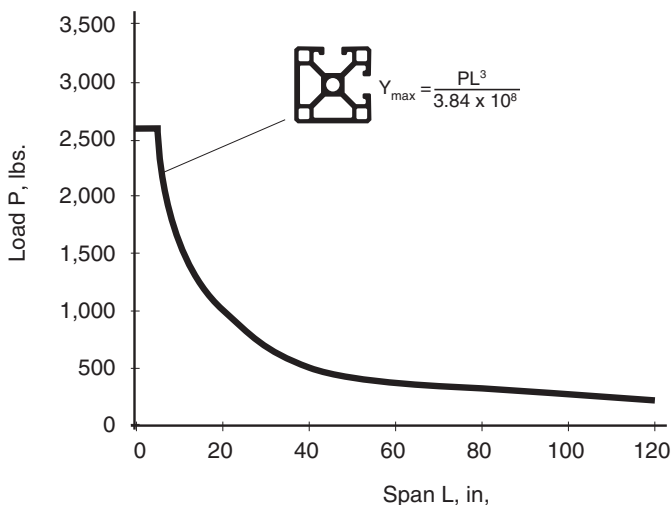
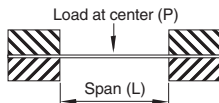

Load condition:  
Fixed at one end, sliding at one end,  
load at center  
Deflection = Y (inches)

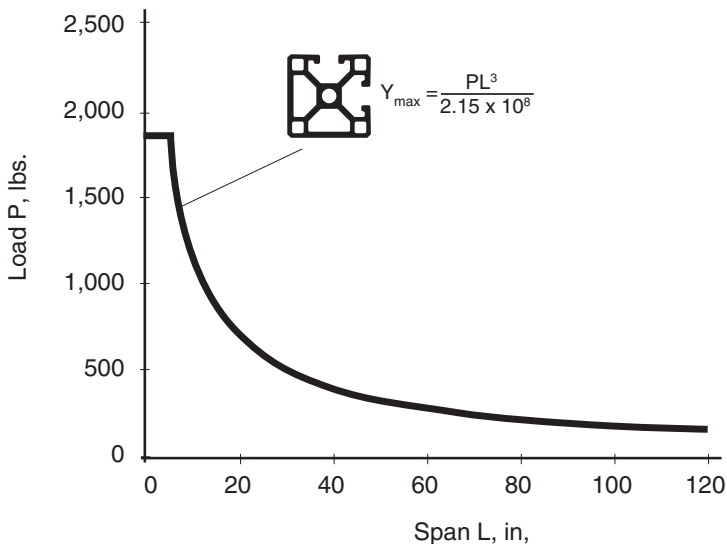
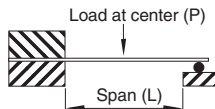

Load condition:  
Fixed at one end,  
load at unsupported end  
Deflection = Y (inches)

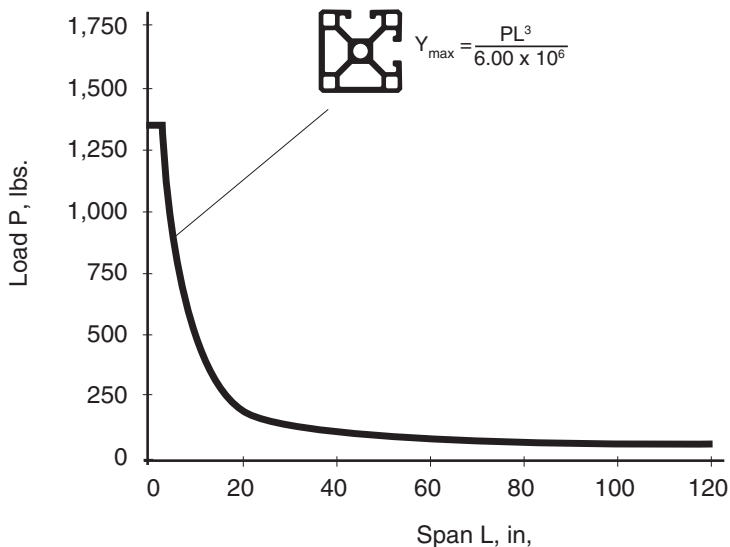
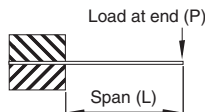

## EX-66

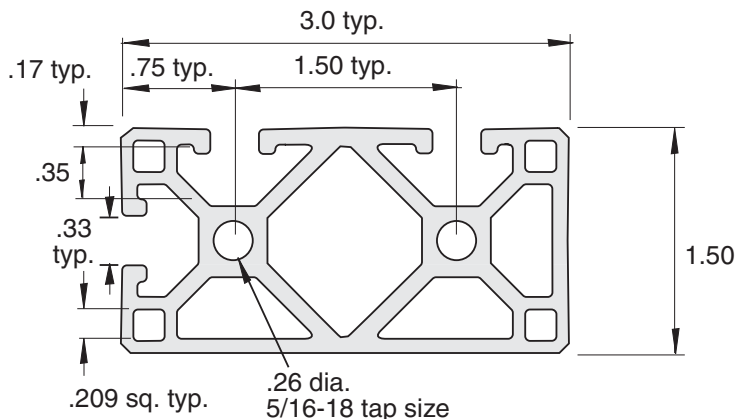

- Finish = Clear anodized
- Material = 6105-T5 Aluminum
- Est. Area = 1.559 Sq. In.
- Weight/ft = 1.833 lbs.
- 96", 192.63" Lengths standard.

### Section Properties:

Moment of Inertia in<sup>4</sup>

Section modulus in<sup>3</sup>



1.385

0.923



0.401

0.535

Load condition:  
Fixed at both ends, load at center  
Deflection = y (inches)

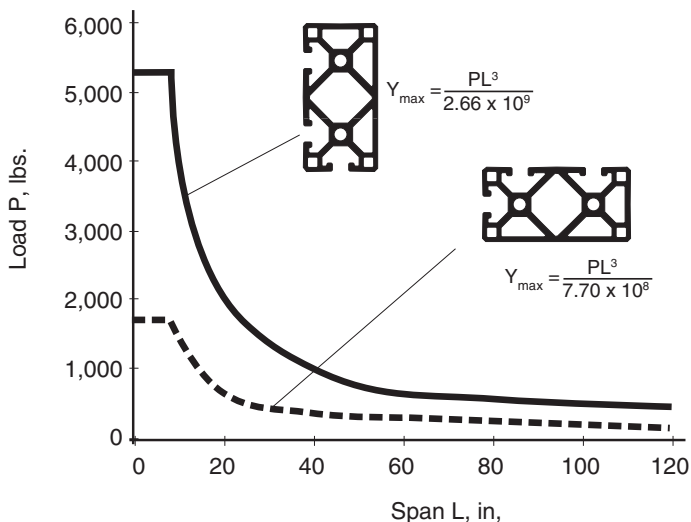
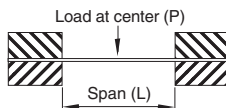

Load condition:  
Fixed at one end, sliding at one end,  
load at center  
Deflection = Y (inches)

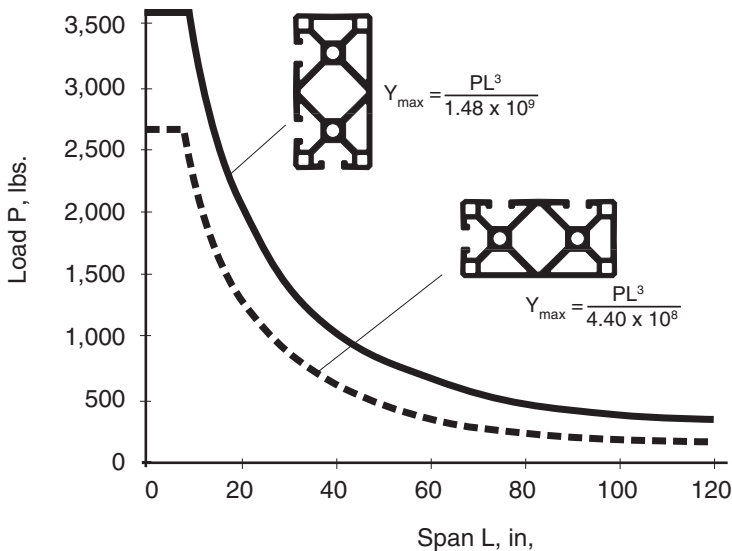
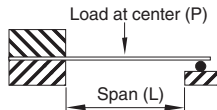

Load condition:  
Fixed at one end,  
load at unsupported end  
Deflection = Y (inches)

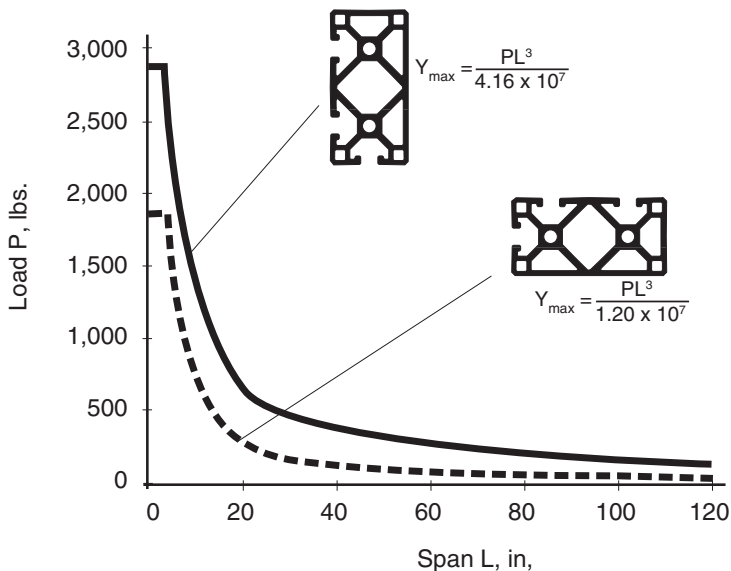
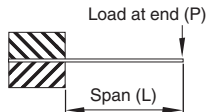



**EX-67**

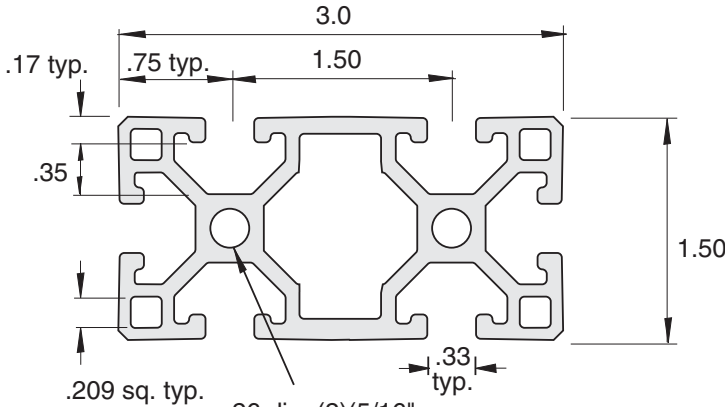

- Finish = Clear anodized
- Material = 6105-T5 Aluminum
- Est. Area = 1.569 Sq. In.
- Weight/ft = 1.845 lbs
- 96", 144.25", 192.63" Lengths standard.

**Section Properties:**

Moment of Intertia in <sup>4</sup>	1.376	0.387
Section modulus in <sup>3</sup>	0.917	0.516

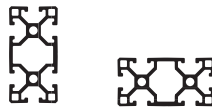

Load condition:  
Fixed at both ends, load at center  
Deflection = y (inches)

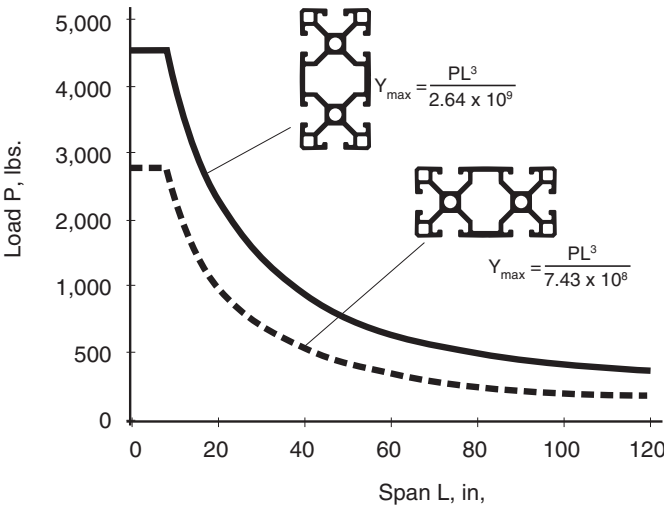
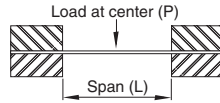

TECHNICAL

Load condition:  
Fixed at one end, sliding at one end,  
load at center  
Deflection = Y (inches)

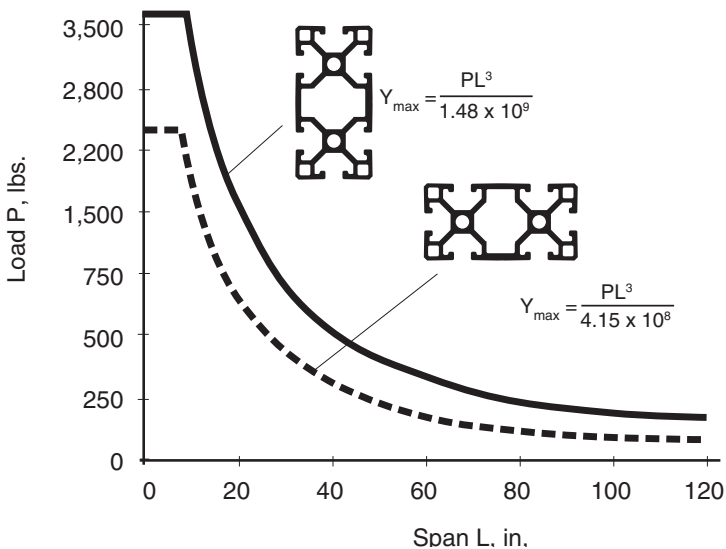
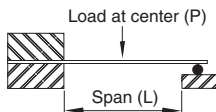

Load condition:  
Fixed at one end,  
load at unsupported end  
Deflection = Y (inches)

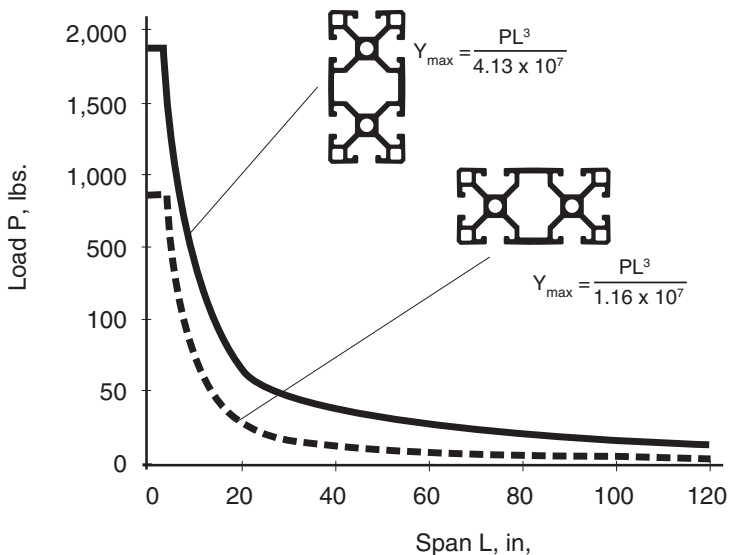
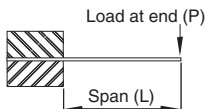

## EX-68

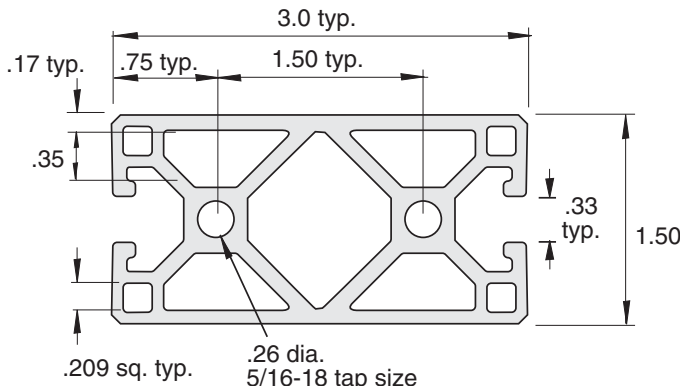

- Finish = Clear anodized
- Material = 6105-T5 Aluminum
- Est. Area = 1.599 Sq. In.
- Weight/ft = 1.880 lbs.
- 96", 192.63" Lengths standard.

### Section Properties:

Moment of Intertia in <sup>4</sup>	1.385	0.401
Section modulus in <sup>3</sup>	0.923	0.535

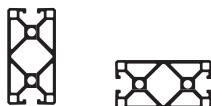

Load condition:  
Fixed at both ends, load at center  
Deflection = y (inches)

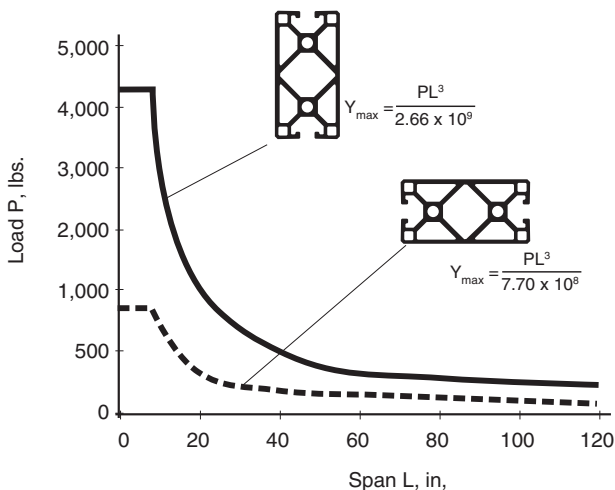
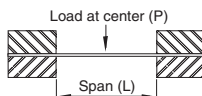

TECHNICAL

Load condition:  
Fixed at one end, sliding at one end,  
load at center  
Deflection = Y (inches)

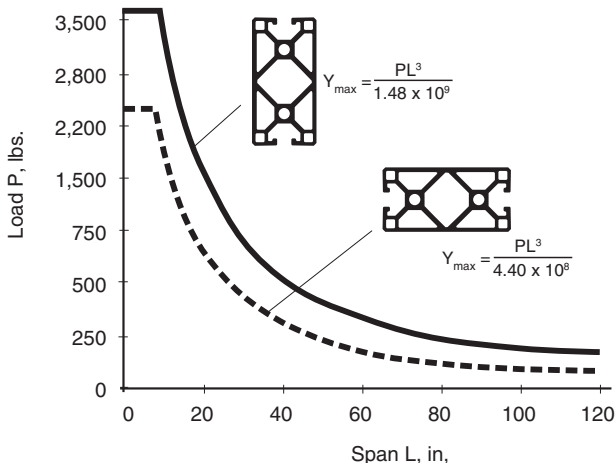
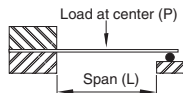

Load condition:  
Fixed at one end,  
load at unsupported end  
Deflection = Y (inches)

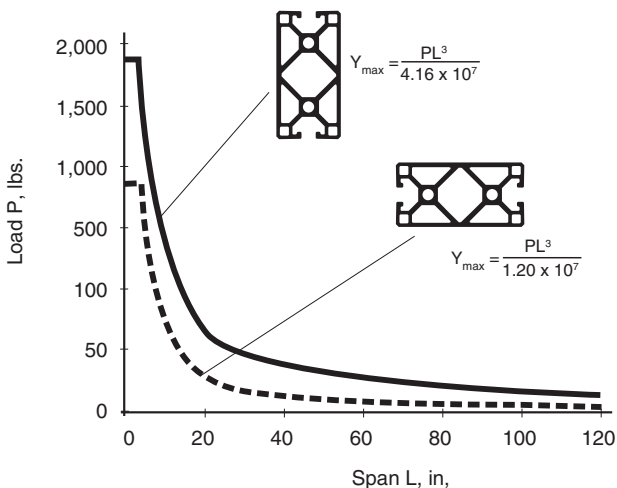
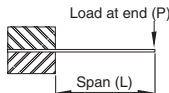

## EX-69

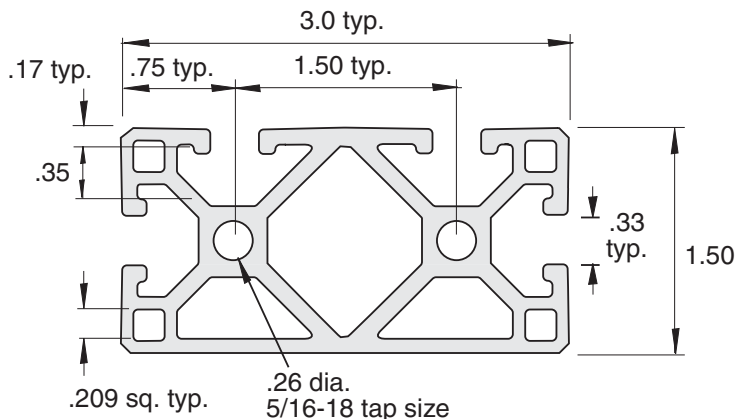

- Finish = Clear anodized
- Material = 6105-T5 Aluminum
- Est. Area = 1.554 Sq. In.
- Weight/ft = 1.828 lbs.
- 96", 192.63" Lengths standard.

### Section Properties:

Moment of Inertia in <sup>4</sup>	1.385	0.401
Section modulus in <sup>3</sup>	0.923	0.535



Load condition:  
Fixed at both ends, load at center  
Deflection = y (inches)

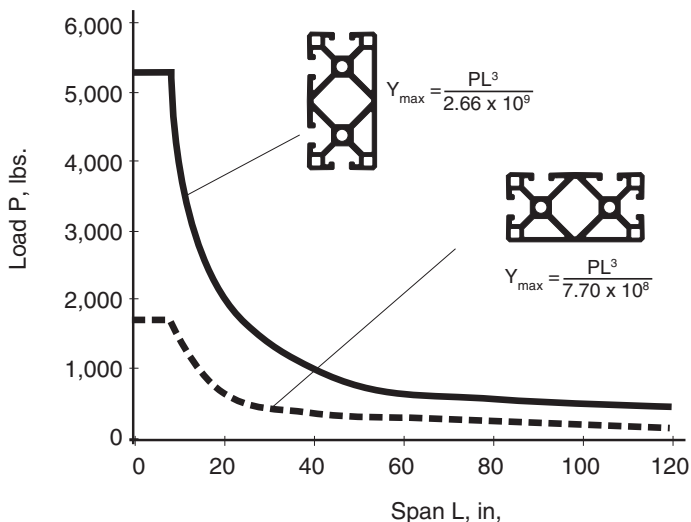
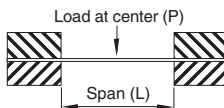

Load condition:  
Fixed at one end, sliding at one end,  
load at center  
Deflection = Y (inches)

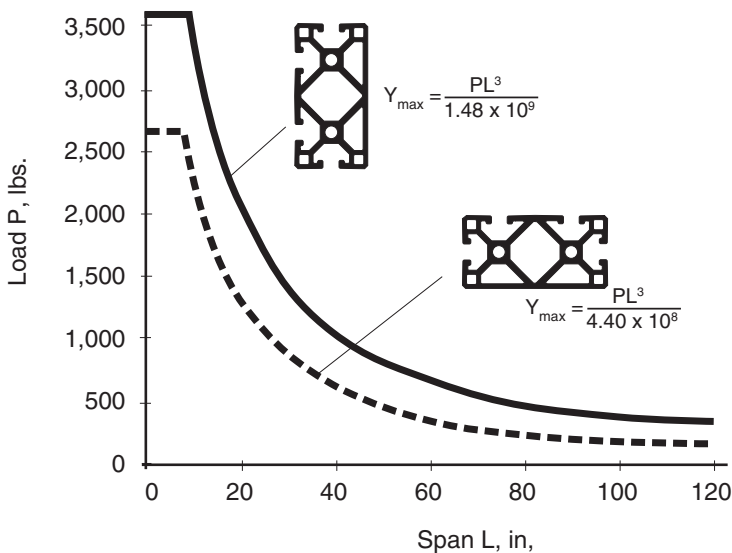
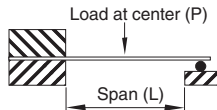

Load condition:  
Fixed at one end,  
load at unsupported end  
Deflection = Y (inches)

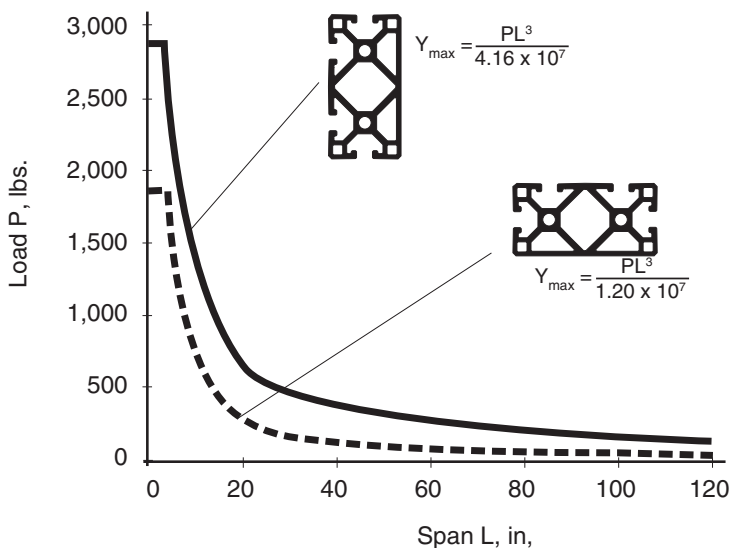
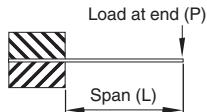

**TECHNICAL**

**EX-83**

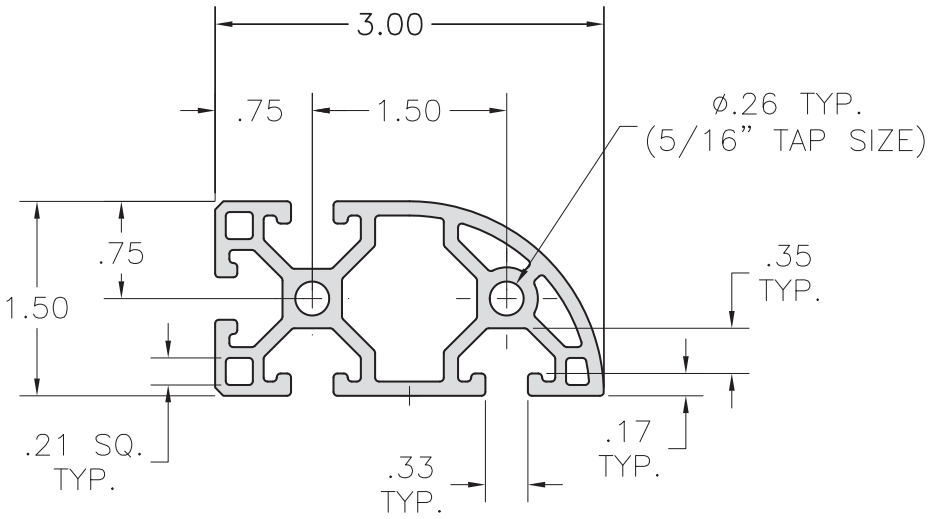

Finish: Clear Anodize  
 Material: 6105-T6 Aluminum  
 Est. Area: 1.464 Sq In.  
 Wt./Ft. 1.722 lbs.  
 Std. Length: 144.25"

Section Properties:  
 Moment of Inertia in<sup>4</sup>  
 Section Modulus in<sup>3</sup>



1.229  
 0.779



0.338  
 0.424

**EX-45HD**

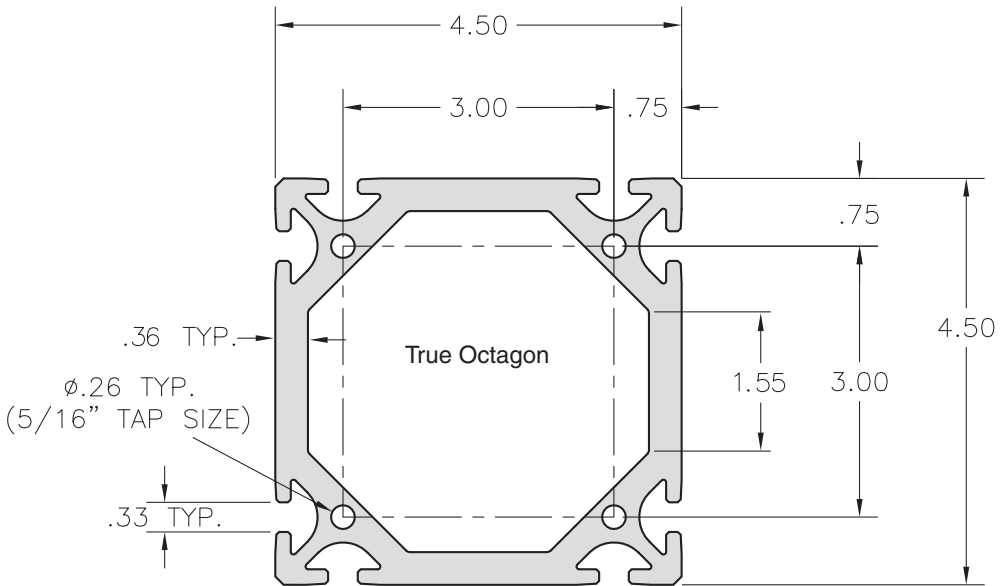

Finish: Mill Finish  
 Material: 6105-T6 Aluminum  
 Est. Area: 6.330 Sq In.  
 Wt./Ft. 7.445 lbs.  
 Std. Length: 192.63"  
 Special cut charge required for  
 non-standard length (EM-1-EX45)

Section Properties:  
 Moment of Inertia in<sup>4</sup>  
 Section Modulus in<sup>3</sup>



16.4  
 6.56



## EX-11

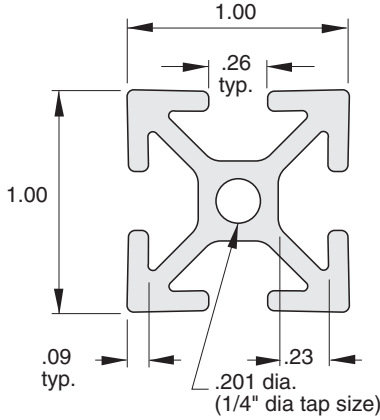

- Finish = Clear anodized
- Material = 6105-T5 Aluminum
- Est. Area = .451 Sq. In.
- Weight/ft = .530 lbs.
- 96", 144.25", 192.63" Lengths standard.

### Section Properties:

Moment of Intertia in<sup>4</sup> .049  
 Section modulus in<sup>3</sup> .097

Load condition:  
 Fixed at both ends, load at center  
 Deflection = y (inches)

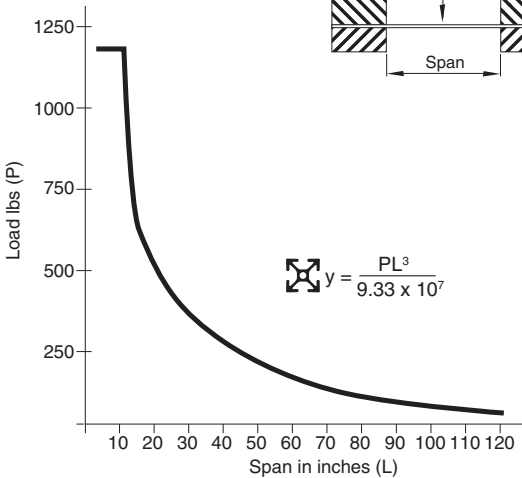
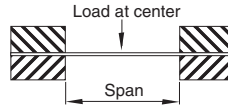

**EX-11**

Load condition:  
Fixed at one end, sliding at one end,  
load at center  
Deflection = Y (inches)

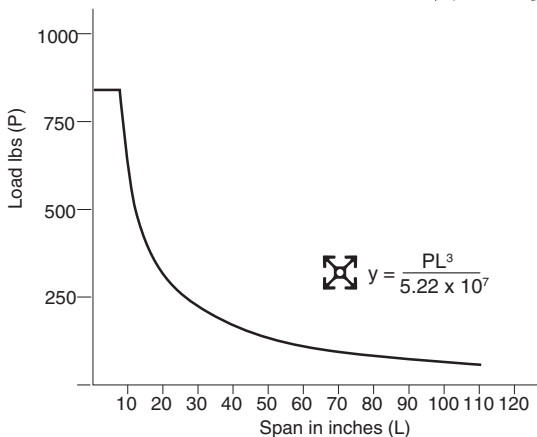
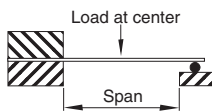

Load condition:  
Fixed at one end,  
load at unsupported end  
Deflection = Y (inches)

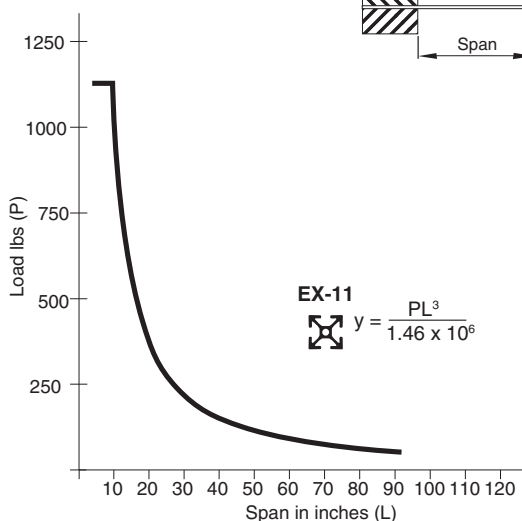
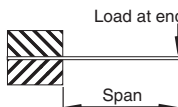

**TECHNICAL**

## EX-12

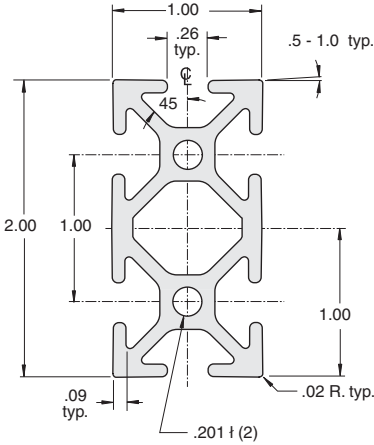

- Finish = Clear anodized
- Material = 6105-T5 Aluminum
- Est. Area = .807 Sq. In.
- Weight/ft = .949 lbs.
- 96", 192.63" Lengths standard.

### Section Properties:

Moment of Intertia in <sup>4</sup>	.316	.088
Section modulus in <sup>3</sup>	.316	.176



Load condition:  
Fixed at both ends, load at center  
Deflection = y (inches)

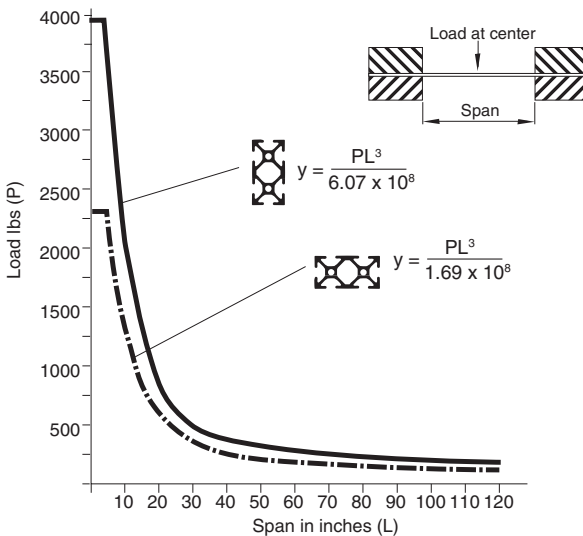

**EX-12**

Load condition:  
Fixed at one end, sliding at one end,  
load at center  
Deflection = Y (inches)

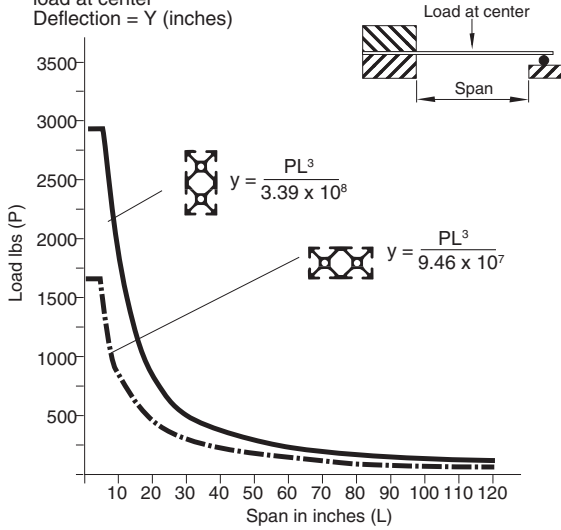

Load condition:  
Fixed at one end,  
load at unsupported end  
Deflection = Y (inches)

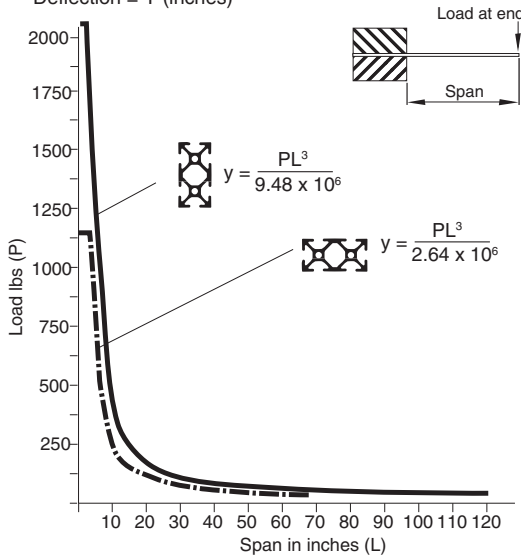

## EX-13

- Finish = Clear anodized
- Material = 6105-T5 Aluminum
- Est. Area = 1.162 Sq. In.
- Weight/ft = 1.367 lbs.
- 96", 192.63" Lengths standard.

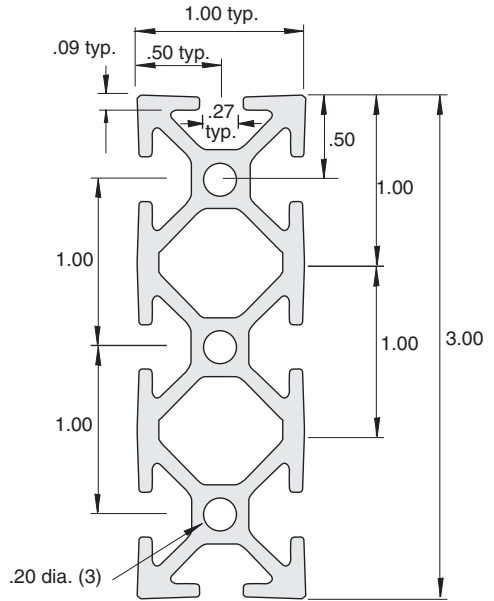

### Section Properties:

Moment of Intertia in <sup>4</sup>	1.376	0.387
Section modulus in <sup>3</sup>	0.917	0.516

Load condition:  
Fixed at both ends, load at center  
Deflection = y (inches)

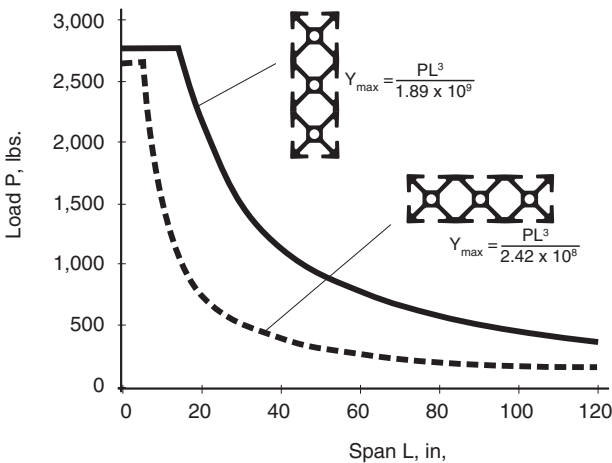
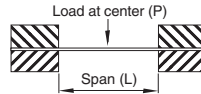

TECHNICAL

Load condition:  
Fixed at one end, sliding at one end,  
load at center  
Deflection = Y (inches)

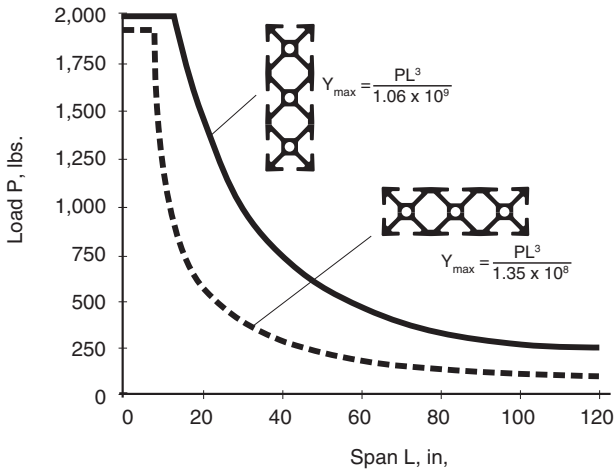
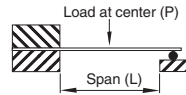

Load condition:  
Fixed at one end,  
load at unsupported end  
Deflection = Y (inches)

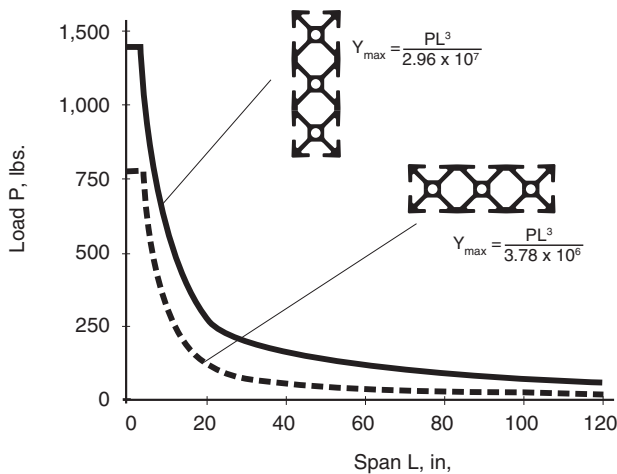
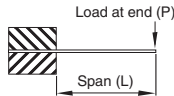

**EX-14**

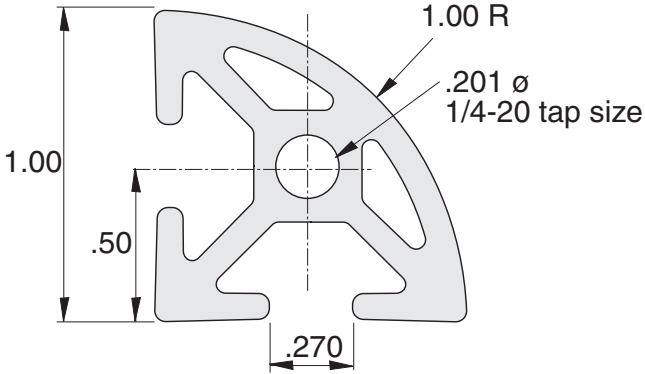

- Finish = Clear anodized
- Material = 6105-T6 Aluminum
- Est. Area = .438 Sq. In.
- Weight/ft = .515 lbs.
- 96", 192.63" Lengths standard.

**Section Properties:**

Moment of Intertia in <sup>4</sup>	.037
Section modulus in <sup>3</sup>	.068

Load condition:  
Fixed at both ends, load at center  
Deflection = y (inches)

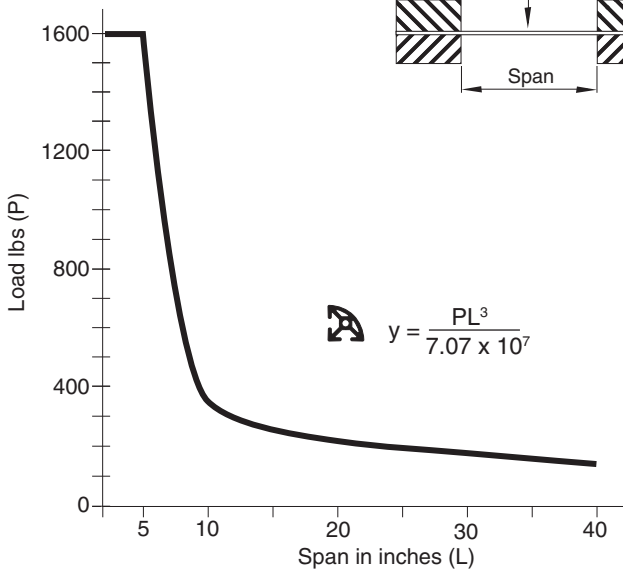
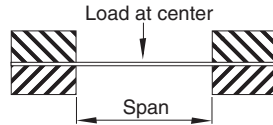

TECHNICAL

**EX-14**

Load condition:  
Fixed at one end, sliding at one end,  
load at center  
Deflection = Y (inches)

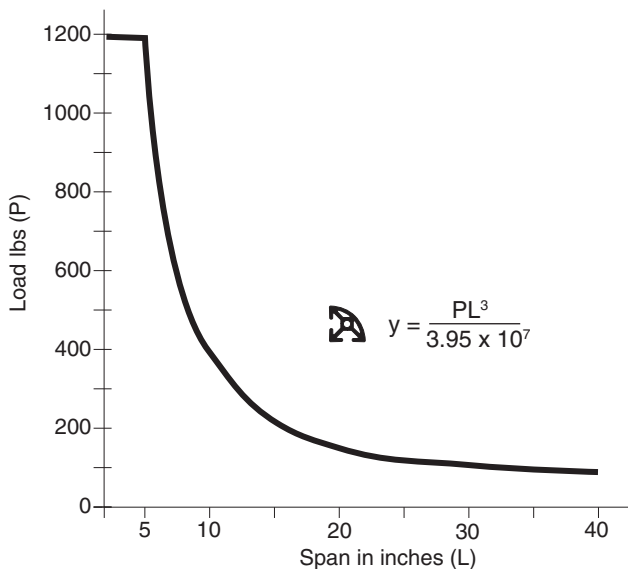
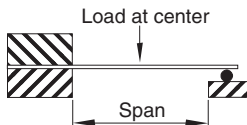

Load condition:  
Fixed at one end,  
load at unsupported end  
Deflection = Y (inches)

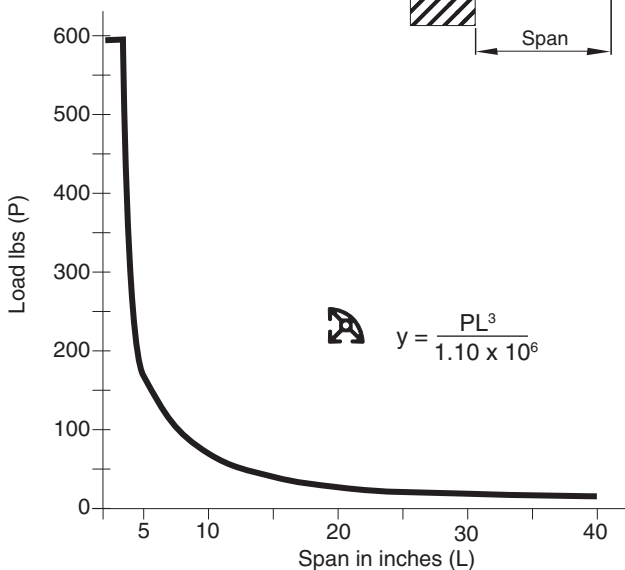
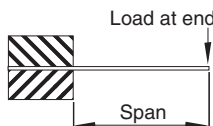

**TECHNICAL**



## EX-22

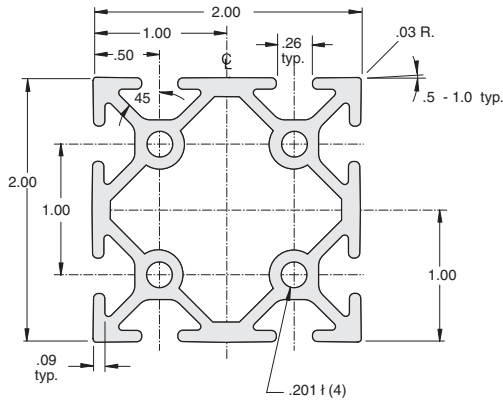

- Finish = Clear anodized
- Material = 6105-T5 Aluminum
- Est. Area = 1.249 Sq. In.
- Weight/ft = 1.468 lbs.
- 96", 192.63" Lengths standard.

### Section Properties:

Moment of Inertia in <sup>4</sup>	.569
Section modulus in <sup>3</sup>	.569

Load condition:  
Fixed at both ends, load at center  
Deflection = y (inches)

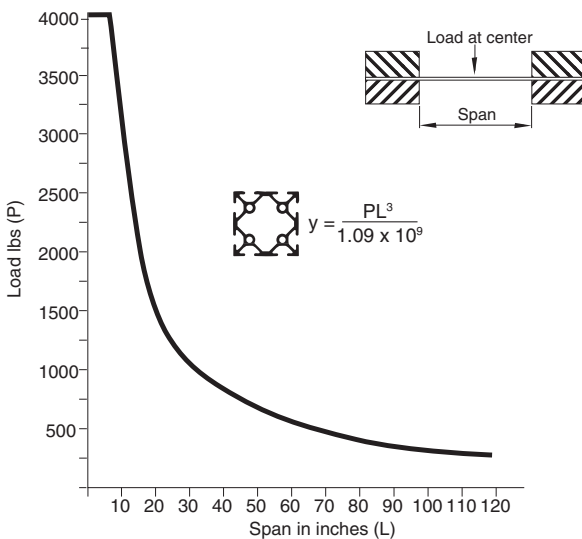

**EX-22**

Load condition:  
Fixed at one end, sliding at one end,  
load at center  
Deflection = Y (inches)

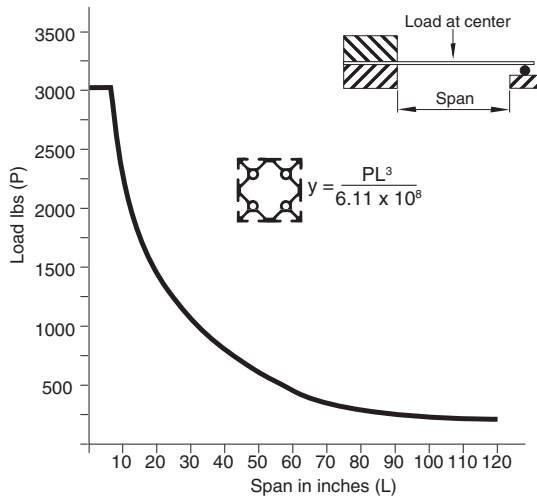

Load condition:  
Fixed at one end,  
load at unsupported end  
Deflection = Y (inches)

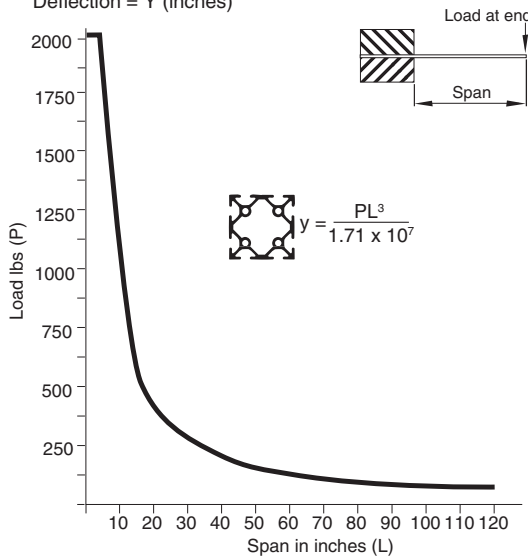

## EX-24

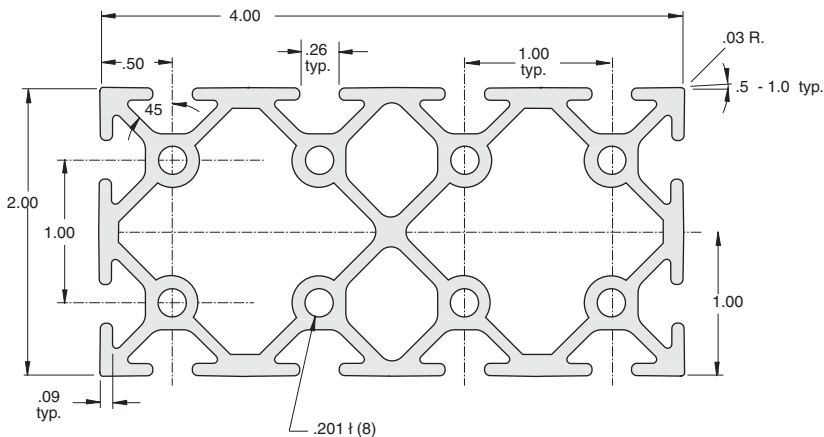

- Finish = Clear anodized
- Material = 6063-T6HT Aluminum
- Est. Area = 2.352 Sq. In.
- Weight/ft = 2.766 lbs.
- 96", 192.63" Lengths standard.

### Section Properties:

Moment of Intertia in <sup>4</sup>	3.634	1.078
Section modulus in <sup>3</sup>	1.817	1.078

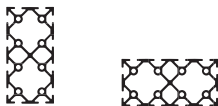

Load condition:  
Fixed at both ends, load at center  
Deflection = y (inches)

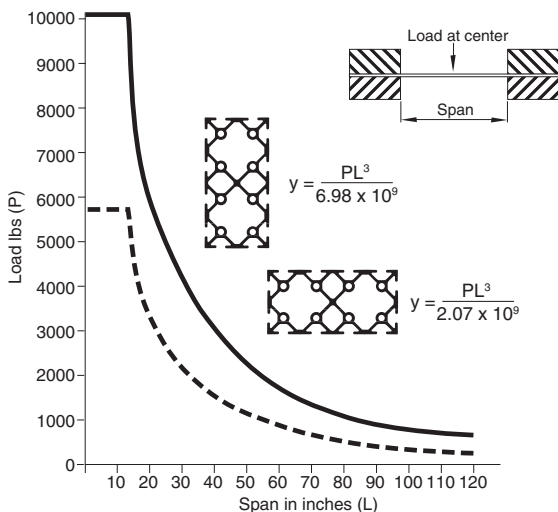

TECHNICAL

Load condition:  
Fixed at one end, sliding at one end,  
load at center  
Deflection = Y (inches)

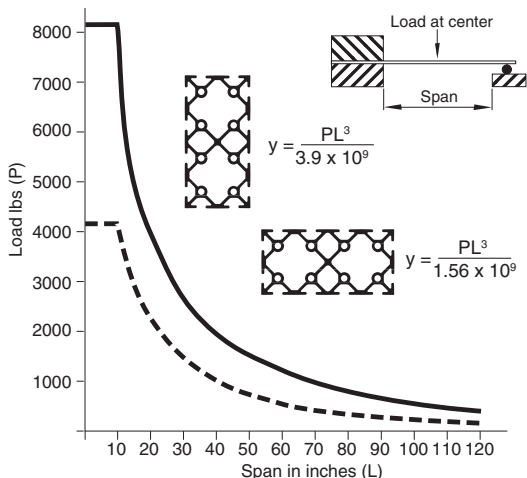

Load condition:  
Fixed at one end,  
load at unsupported end  
Deflection = Y (inches)

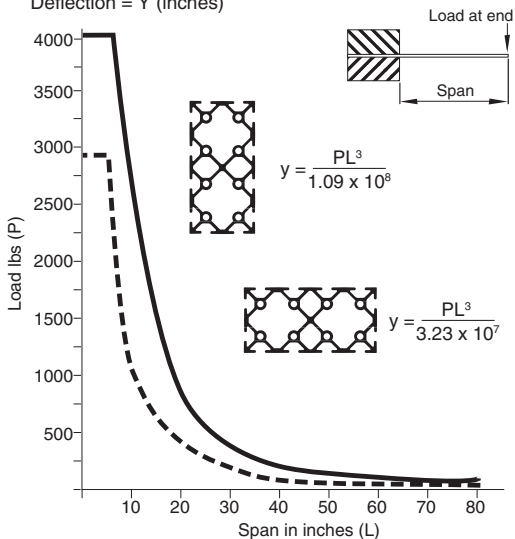

## EX-70

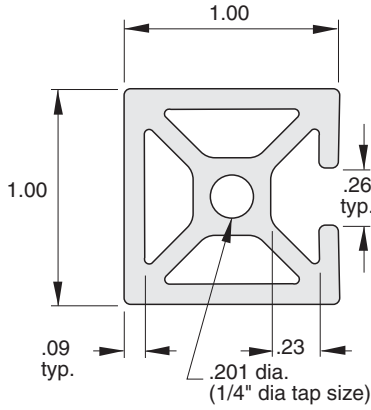

- Finish = Clear anodized
- Material = 6105-T5 Aluminum
- Est. Area = .451 Sq. In.
- Weight/ft = .576 lbs.
- 96", 192.63" Lengths standard.

### Section Properties:

Moment of Intertia in <sup>4</sup>	.057	.052
Section modulus in <sup>3</sup>	.114	.099



Load condition:  
Fixed at both ends, load at center  
Deflection = y (inches)

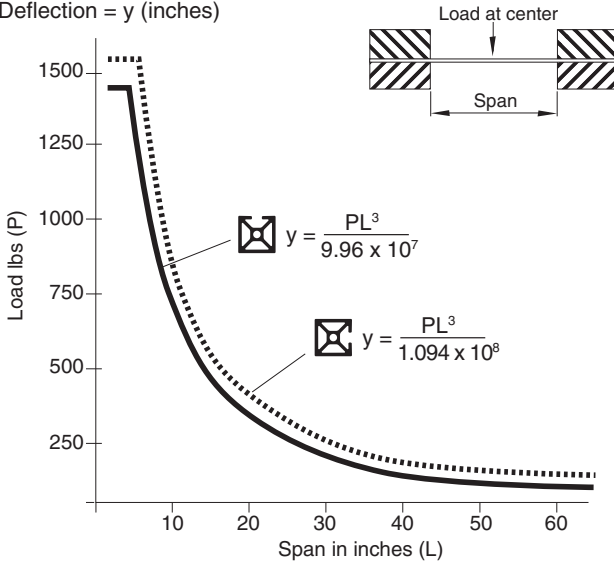

Load condition:  
Fixed at one end, sliding at one end,  
load at center  
Deflection = Y (inches)

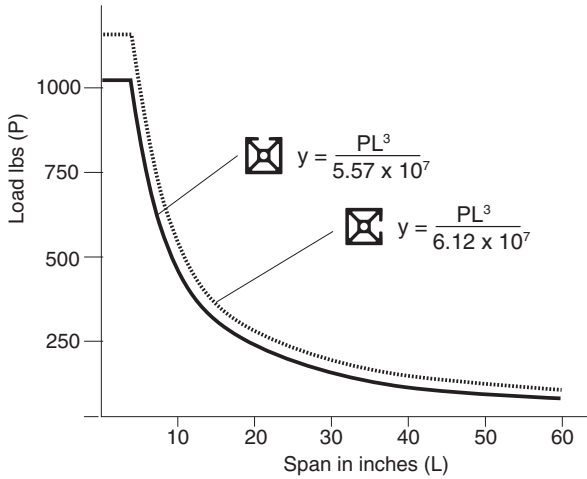
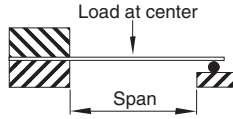

Load condition:  
Fixed at one end,  
load at unsupported end  
Deflection = Y (inches)

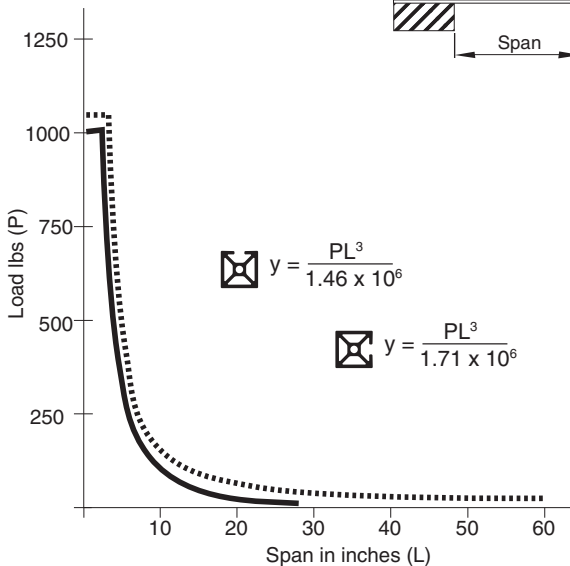
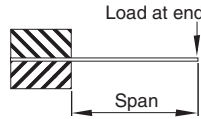

## EX-71

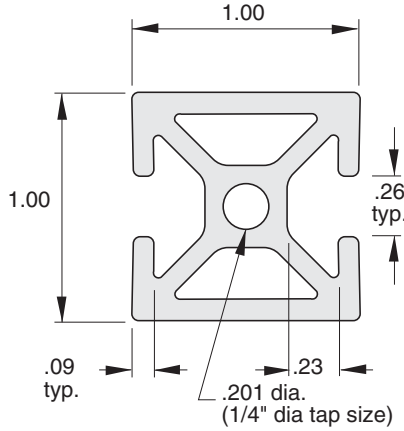

- Finish = Clear anodized
- Material = 6105-T5 Aluminum
- Est. Area = .451 Sq. In.
- Weight/ft = .550 lbs.
- 96", 192.63" Lengths standard.

### Section Properties:

Moment of Intertia in <sup>4</sup>	.057	.046
Section modulus in <sup>3</sup>	.114	.093



Load condition:  
Fixed at both ends, load at center  
Deflection = y (inches)

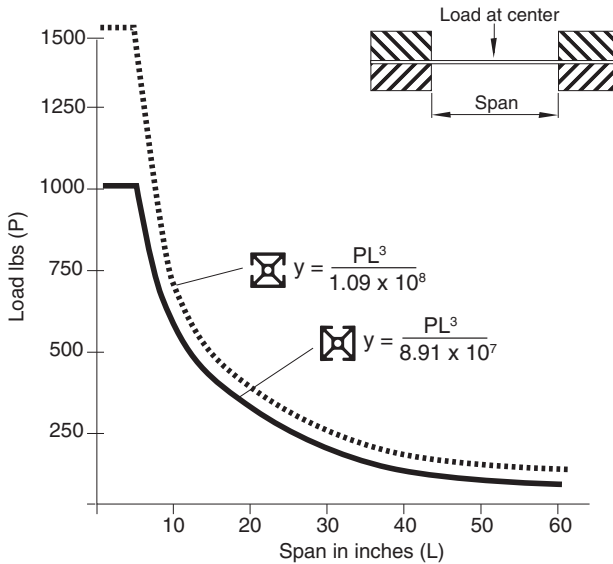

Load condition:  
Fixed at one end, sliding at one end,  
load at center  
Deflection = Y (inches)

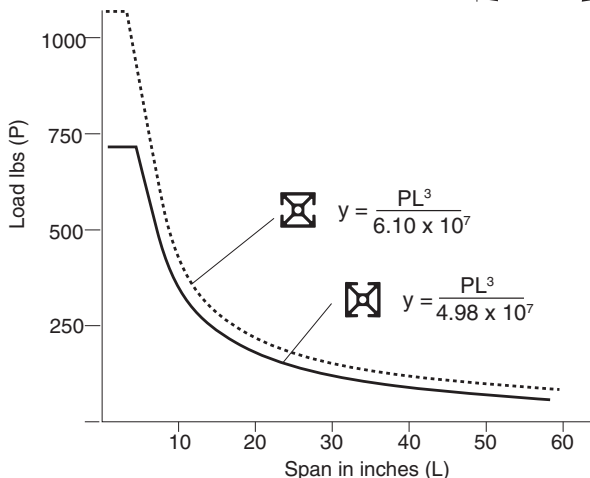
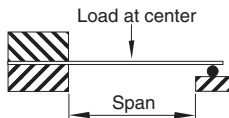

Load condition:  
Fixed end at one end,  
load at unsupported end  
Deflection = Y (inches)

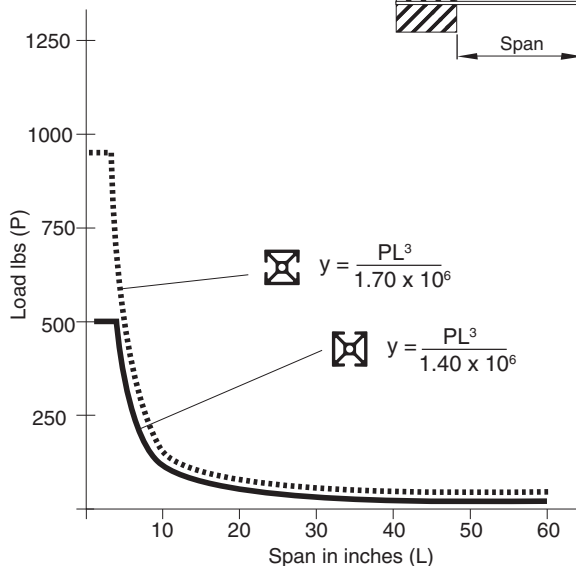
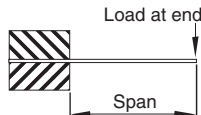



## EX-72

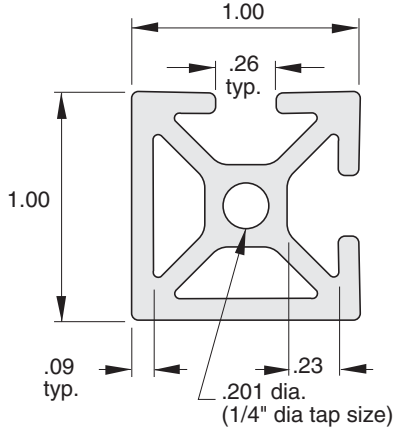

- Finish = Clear anodized
- Material = 6105-T5 Aluminum
- Est. Area = .451 Sq. In.
- Weight/ft = .546 lbs.
- 96", 192.63" Lengths standard.

### Section Properties:

Moment of Intertia in<sup>4</sup> .051  
 Section modulus in<sup>3</sup> .098

Load condition:  
 Fixed at both ends, load at center  
 Deflection = y (inches)

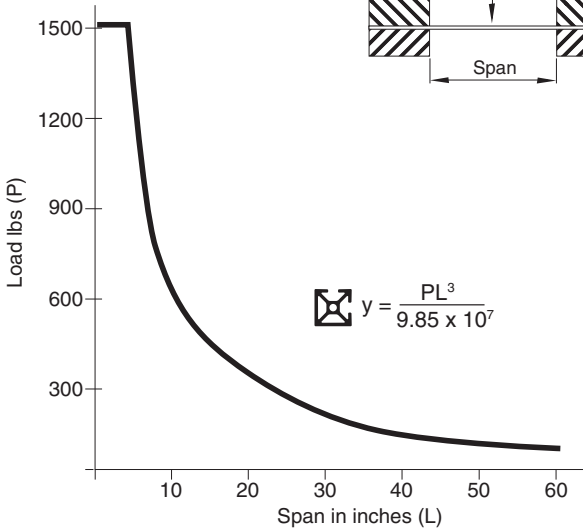
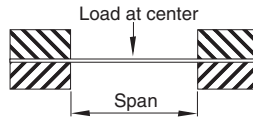

Load condition:  
Fixed at one end, sliding at one end,  
load at center  
Deflection = Y (inches)

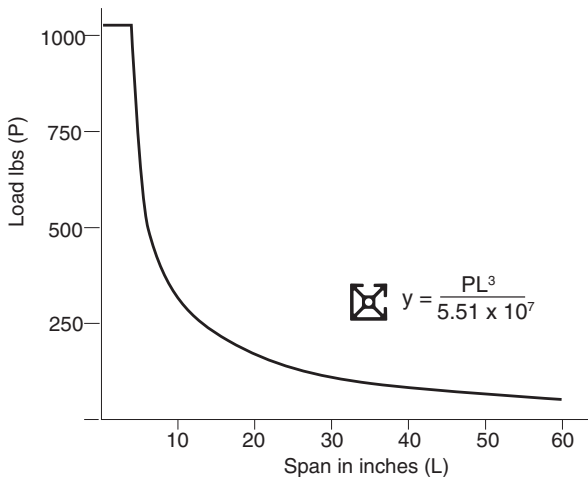
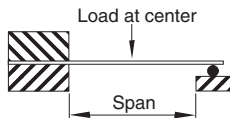

Load condition:  
Fixed at one end,  
load at unsupported end  
Deflection = Y (inches)

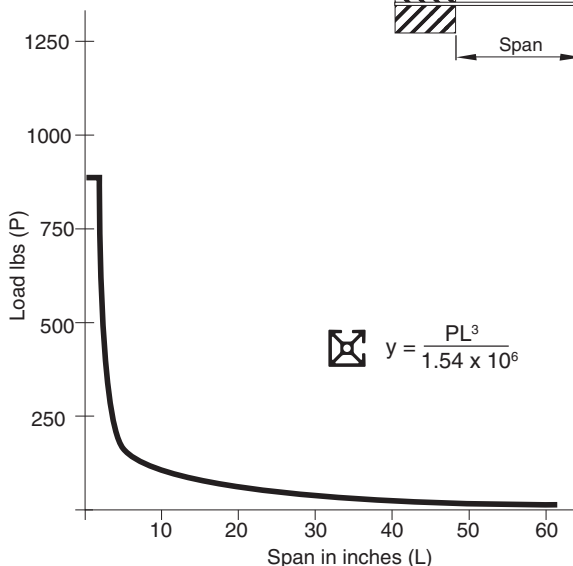
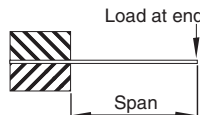

## EX-73

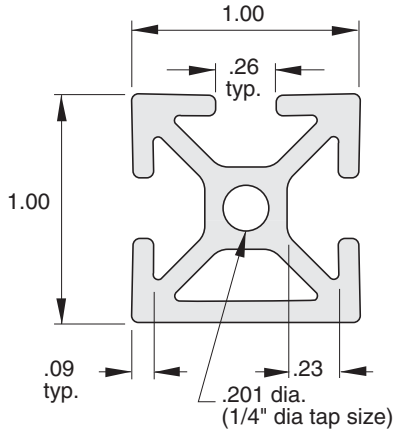

- Finish = Clear anodized
- Material = 6105-T5 Aluminum
- Est. Area = .451 Sq. In.
- Weight/ft = .523 lbs.
- 96", 192.63" Lengths standard.

### Section Properties:

Moment of Intertia in <sup>4</sup>	.051	.046
Section modulus in <sup>3</sup>	.099	.092



Load condition:  
Fixed at both ends, load at center  
Deflection = y (inches)

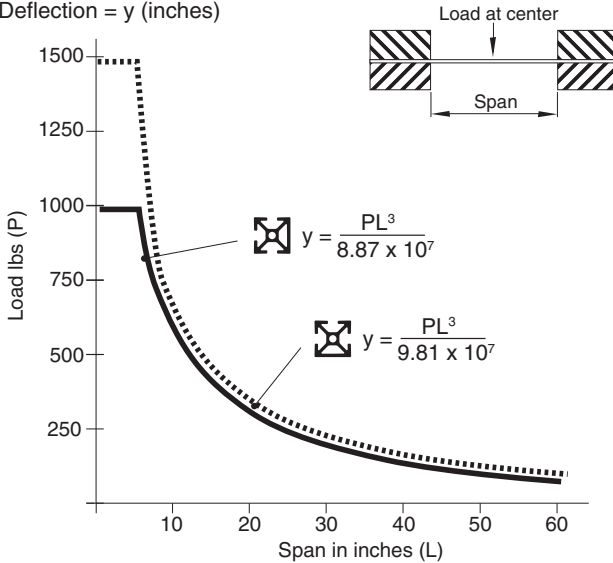

Load condition:  
Fixed at one end, sliding at one end,  
load at center  
Deflection = Y (inches)

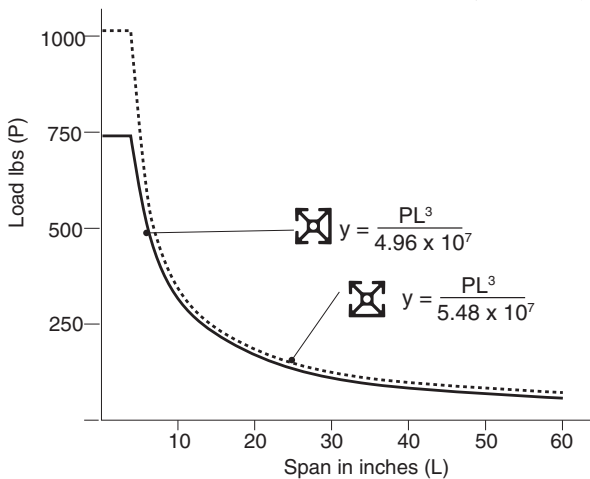
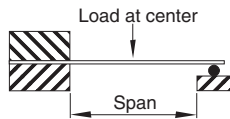

Load condition:  
Fixed at one end,  
load at unsupported end  
Deflection = Y (inches)

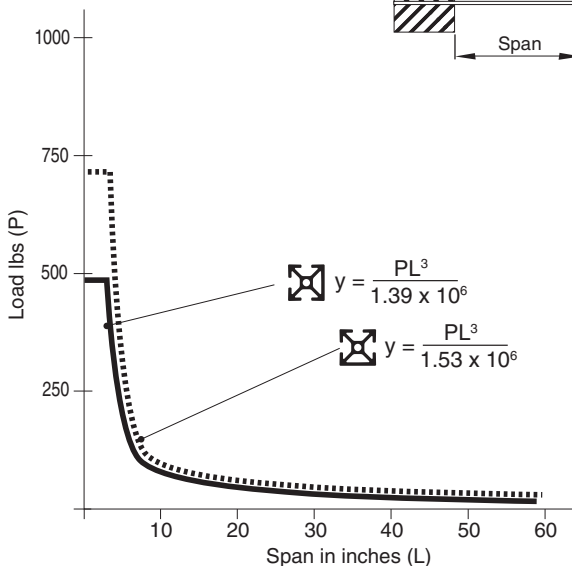
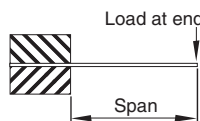

FRAME-WORLD's blank angle bracket profiles are made from aluminum and are provided with a standard mill finish. Clear anodized finish is also available. They are stocked in 8 ft. and 12 ft. lengths.

## EX-15

### EX-15-ANDZ

1.68 lb/ft

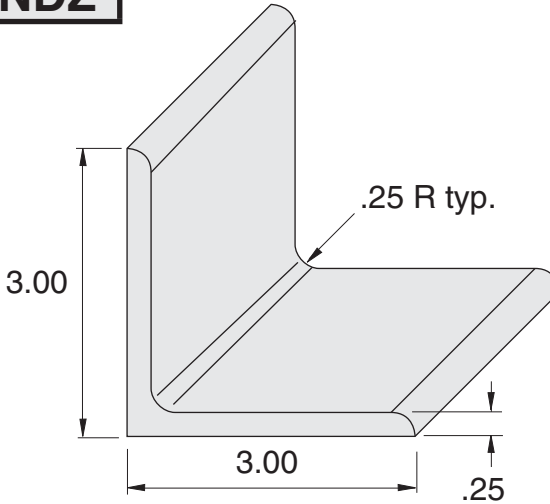

## EX-16

### EX-16-ANDZ

.81 lb/ft

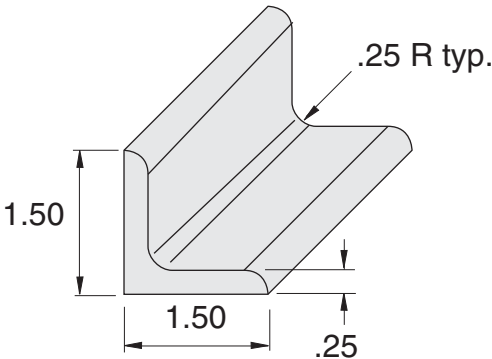

For special lengths, consult the factory.

FRAME-WORLD's blank angle bracket profiles are made from aluminum and are provided with a standard mill finish. Clear anodized finish is also available. They are stocked in 8 ft. and 12 ft. lengths.

**EX-17****EX-17-ANDZ**

.83 lb/ft

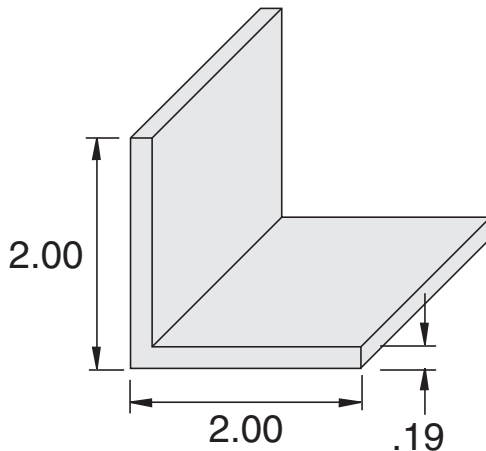
**EX-18****EX-18-ANDZ**

.40 lb/ft

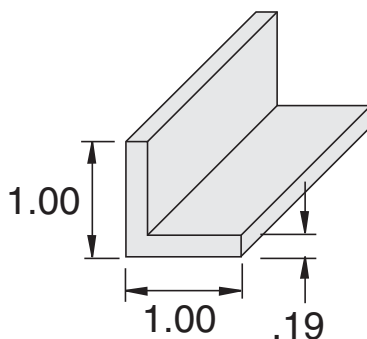

For special lengths, consult the factory.

FRAME-WORLD Blank Angle Profiles are made from aluminum and are provided with a standard mill finish. They are stocked in 8 ft. and 12 ft. lengths

**EX-34**

**EX-34-ANDZ**

1.25 lb/ft

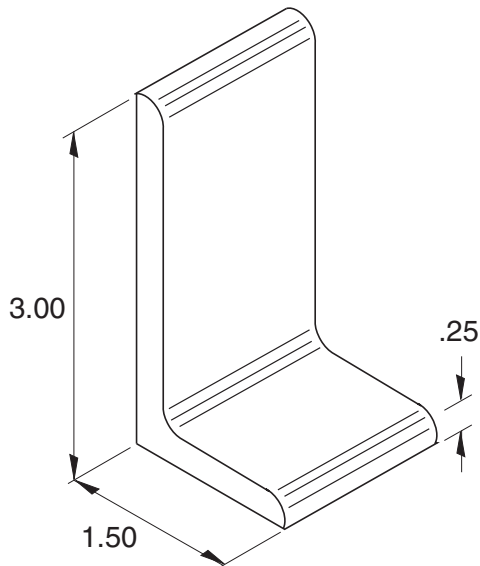

For special lengths, consult the factory.

**Mill Finish**

**EX-53**

.24 lb/ft

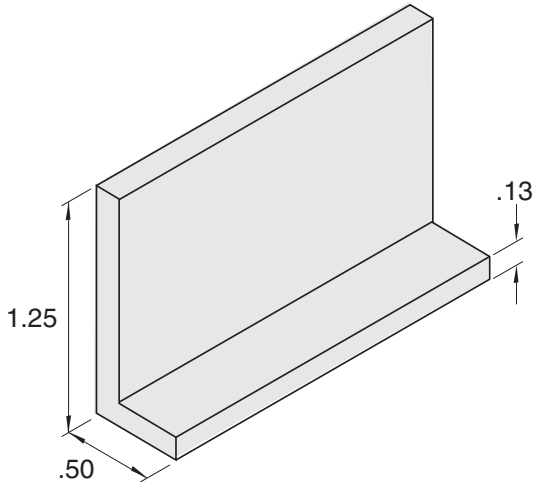

Standard Length 96", 192.63"

Material: Aluminum  
Finish: Mill Finish

For special lengths, consult the factory.



# Angle Bracket Profiles



FRAME-WORLD's blank angle bracket profiles are made from aluminum and are provided with a standard mill finish. Clear anodized finish is also available. They are stocked in 8 ft. and 12 ft. lengths.

**EX-30**  
**EX-30-ANDZ**

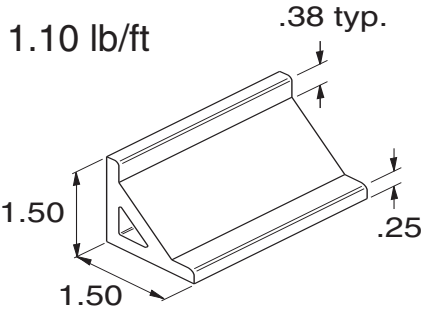

**EX-32**  
**EX-32-ANDZ**

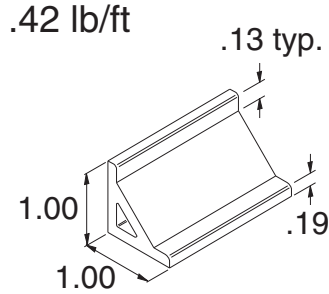

**EX-31**  
**EX-31-ANDZ**

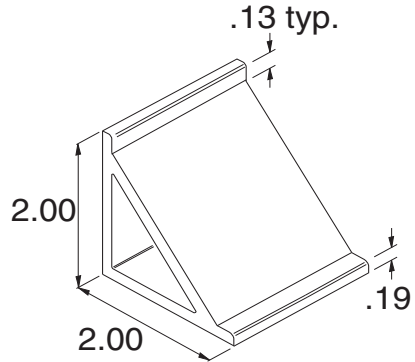
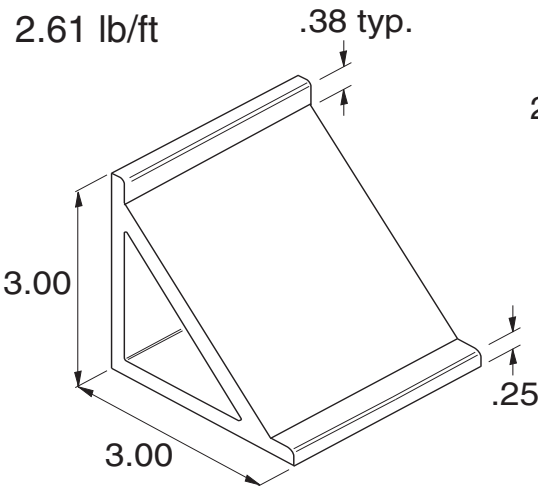

**EX-33**  
**EX-33-ANDZ**

1.33 lb/ft

For special lengths, consult the factory.

TECHNICAL

FRAME-WORLD can provide you with a kit that is ready to assemble. We will provide machining services such as access holes, taps, cuts and counterbores. We can also provide miter cuts and any special milling, drilling or tapping requirements that you may have.

In addition to the items within this catalog, FRAME-WORLD can also provide panels cut to size. Materials can be Acrylic (Plexiglass®), Polycarbonate (Lexan®) expanded PVC (Sintra®) or ABS (Haircell). This also includes any drilling, tapping or machining required for panel mounting.

Customized packaging is also available, such as kits for multiple quantities of the same item (i.e. frame, fixture, panel, etc.) or labeling individual components of one item.

For all special services and for any parts not shown in this catalog, please contact our Application Group.

**Standard Machining Services****Part No.**

1. Cut to length 5/16" or 1/4" slot profiles
  - Any profile shape (except EX-45HD)
  - Length tolerance = +.015"
  - Squareness = .002" per inch

**EM-1**

2. Cut to length EX-45HD
  - Length tolerance = +.015"
  - Squareness = .002" per inch

**EM-1-EX-45**

3. End hole tap
  - A. 5/16" slot profiles
    - 5/16"-18 x 1.0 deep thread
      - .260 dia. extruded hole size
      - m8 x 1.25 on request
  - B. 1/4" slot profiles
    - 1/4"-20 x .75 deep thread
      - .201 dia. extruded hole size
      - m6 x 1.0 on request

**EM-2****EM-2**

4. T-slot identification

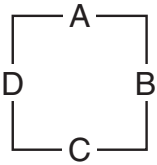

**EX-1  
EX-6  
EX-9  
EX-11**

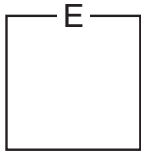

**EX-61  
EX-70  
EX-52**

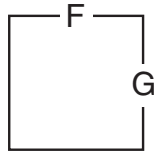

**EX-65  
EX-72**

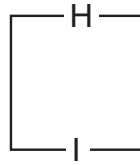

**EX-64  
EX-71  
EX-54**

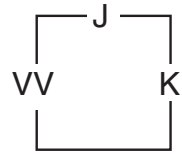

**EX-63  
EX-73**

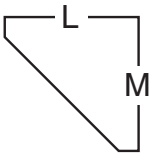

**EX-7  
EX-14  
EX-8  
EX-82**

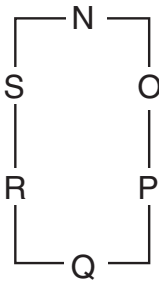

**EX-67  
EX-2  
EX-12**

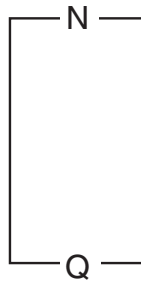

**EX-68**



**EX-66**

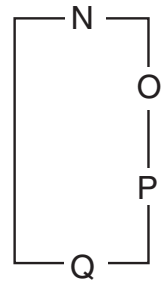

**EX-69**

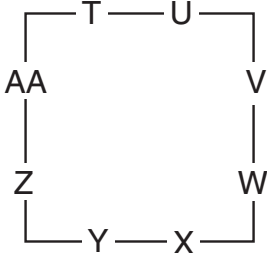

**EX-3  
EX-37  
EX-22**

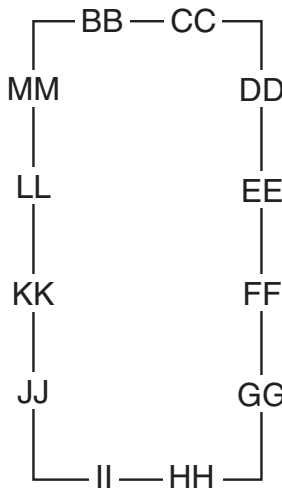

**EX-36  
EX-24**

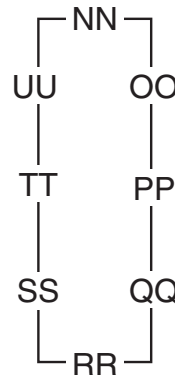

**EX-26**

Part No.

5. Access Hole Drill

- A. For 5/16" wide slot profiles  
the drill dia. = .31"  
all the way through
- B. For 1/4" wide slot profiles  
the drill dia. = .25"  
all the way through.

EM-3

EM-3

Example:

(2) pcs EX-1 x 60.0" with EM-3's on A & B at .75 from each end and on B at 30.0"

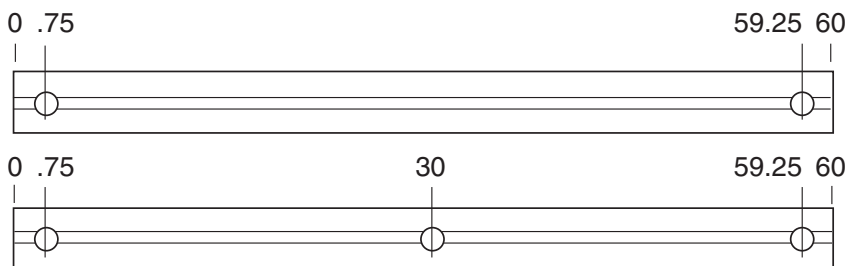

Total EM-1 cuts = 2

Total EM-3 Drills = 10

6. C'bore or C'sink Hole Drill

EM-3C

Specify type and location for a countersink hole in a panel or extrusion.

Example:

For a panel: Drill and C'sink for 5/16-18 FHCS per dwg (must submit sketch of panel)

For an extrusion: Drill and C'bore for 5/16-18 SHCS slot [A] @ 0.75, 2.25 from end.

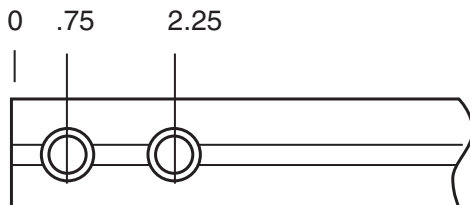

Part No.

7. Anchor Fastener Counter Bores

- A. For 5/16" slot profiles the counterbore  
dia. = .812 x .650 deep  
location is .875 from the end

**EM-5**

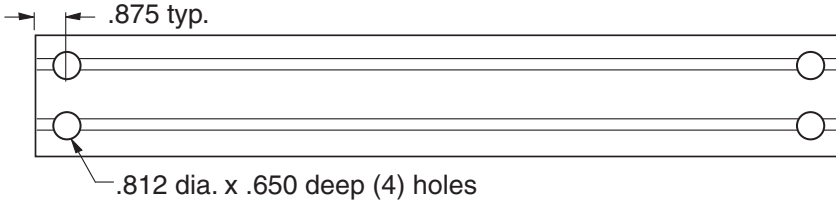

Example

(2) EX-2 x 30.0" with EM-5's at O & P both ends

Total EM-1 cuts = 2

Total EM-5 counterbores = 8

Total EF-62 anchor fasteners = 8

- B. For 1/4" slot profiles the counterbore  
dia. = .562 x .445 deep  
location is .500 from the end

**EM-7**

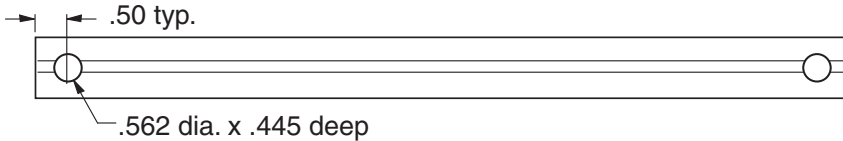

Example

(2) EX-12 x 50.0" with EM-7's at N & Q both ends

Total EM-1 cuts = 2

Total EM-7 counterbores = 8

Total 11-242 anchor fasteners = 8

**Part No.**

- C. For 5/16" slot profiles using double anchor fasteners EF-63 & EF-64 the counterbore dia. = .812 x .650 location is .875 from the end

**EM-5**

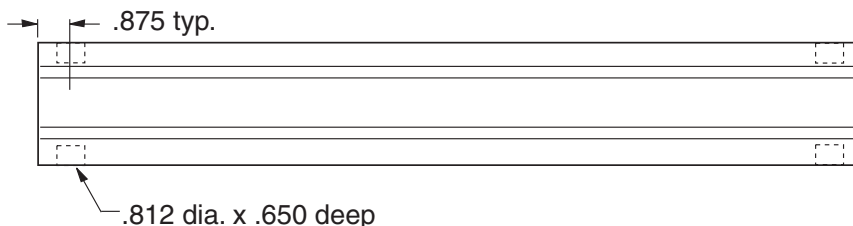

Example

- (2) EX-2 x 30.0" with EM-5's at N & Q both ends  
Total EM-1 cuts = 2  
Total EM-5 counterbores = 8  
Total EF-64 anchor fasteners = 4

- D. For 1/4" slot profiles using double anchor fasteners 11-248 & 11-249, the counterbore dia. = .562 x .445 deep location is .500 from the end

**EM-7**

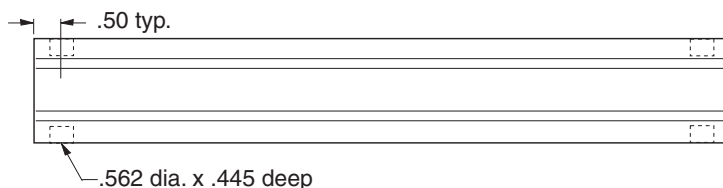

Example

- (2) EX-12 x 20.0" with EM-7's at N & Q both ends  
Total EM-1 cuts = 2  
Total EM-7 counterbores = 8  
Total 11-249 anchor fasteners = 4

Part No.

8. Anchor Butt Fastener Counterbores

- A. For 5/16" wide slot profiles the counterbore dia. = .812 x .650 deep. Location is .75 from the end

**EM-8**

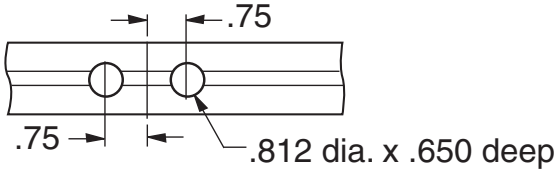

Example: (for a 300" long piece)

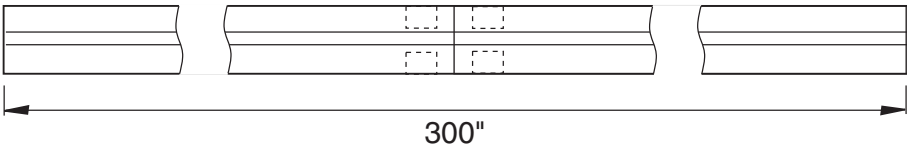

- (2) EX-1 x 150.0
- (2) EM-1
- (4) EM-8
- (2) EF-61

- B. For 1/4" wide slot profiles the counterbore dia. = .562 x .445 deep. Location is .438 from the end

**EM-9**

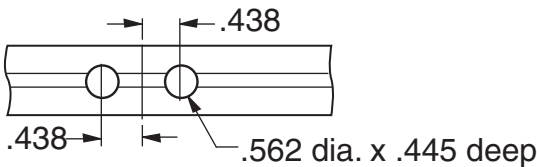

Example: (for a 200" long piece)

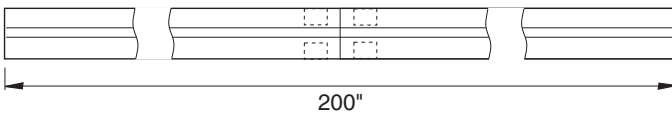

- (2) EX-11 x 100.0
- (2) EM-1
- (4) EM-9
- (2) 11-243

**Part No.  
EM-13**

9. Set Screw Anchor Fastener Counterbore

For 5/16" wide slot profiles using and EF-49 fastener,  
an EM-13 counterbore dia = .625 dia x 1.00 deep  
at a distance of 1.312" from the end of the extrusion.

Example:

EX-65 ; 32.000" ; EM-13 [F] @ 1.312, 30.688

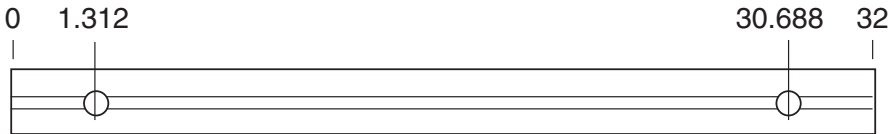

10. Wire Mesh and Plastic Panels Cut to Size

Panels any side  $\leq$  48.0"

Panels any side  $>$  48.0"

**EM-4S**  
**EM-4L**

- A. Wire Mesh and Plastic Panels  
are sold by the number of square feet
- B. To calculate square feet,  
multiply the length by width (in inches)  
and then divide by 144.  
Round up to nearest square foot.

C. Example:

(1) EB-38-1 that is 24" x 47"

Order:

(8) sq ft EB-38-1 (1) @ 24" x 47"

(1) EM-4S

Total Sq. Ft. =  $\frac{47.0 \times 24.0}{144.0} = (8)$  sq. ft. EB-38-1



11. Clearance Hole in a Panel **EM-3P**  
For clearance holes drilled into panel material,  
include an EM-3P. Please provide a sketch.

12. Notch in Panel or Mesh **EM-4N**  
For notches in panels or mesh, include  
an EM-4N for each notch. Please provide a sketch.

13. Extrusion Mitre Cuts & Counter Bores **EM-6**  
Miter cut per end **EM-10**  
Counter bore & hardware per end

(1) EM-6/Cut Piece

Example:

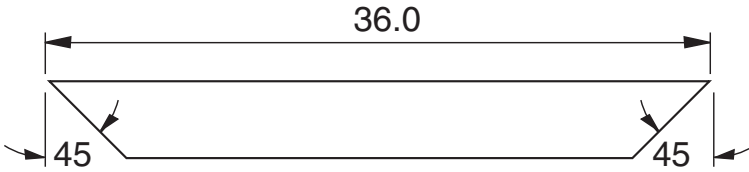

Order:

- (1) EX-1 x 36.0
- (2) EM-6
- (2) EM-10 (times (2) for double slot, i.e. EX-2)

Note: for custom angles, consult the factory.

When comparing all costs in the fabrication of a typical machine or table frame using FRAME-WORLD components versus steel weldments, most users realize a 15 to 25% savings. Here are the reasons, or extra steps and equipment in weldment structures:

- Welding fixtures and clamps
- Welding time
- Grinding equipment and grinding of welds
- Clean and degrease
- Drill, tapping or reaming mounting holes
- Deburr
- Primer
- Paint frame and touch up after mounting

It's easy to see the savings and esthetic effect of FRAME-WORLD.

### Parts List

- 8 - EX-3-30 Extrusion
- 2 - EX-3-48 Extrusion
- 2 - EX-3-42 Extrusion
- 4 - EB-9 Angle Bracket
- 12 - EB-12 Angle Bracket
- 4 - EBP-2 Leveling Plate
- 4 - EAL Adjustable Leg
- 4 - EF-19-C Plastic End Plate
- 16 - EF-62 Anchor Fastener

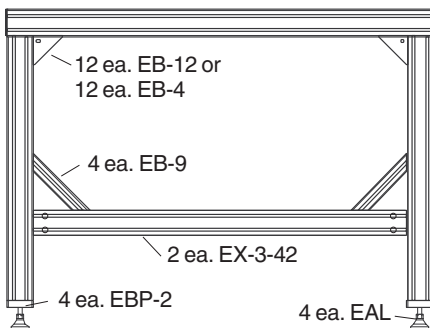
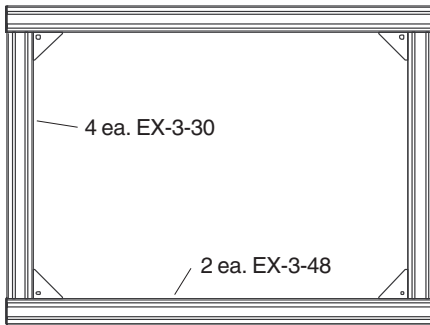

4 ea. EF-19-C

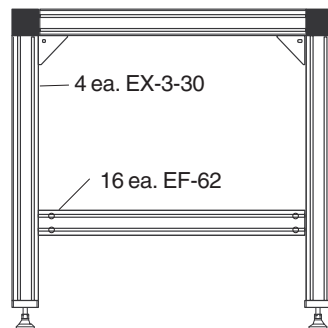



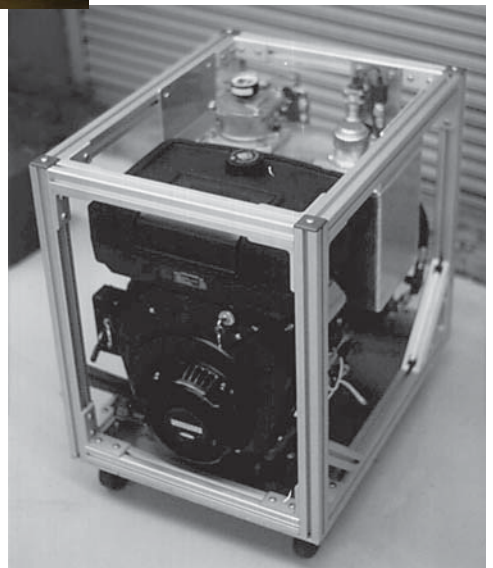
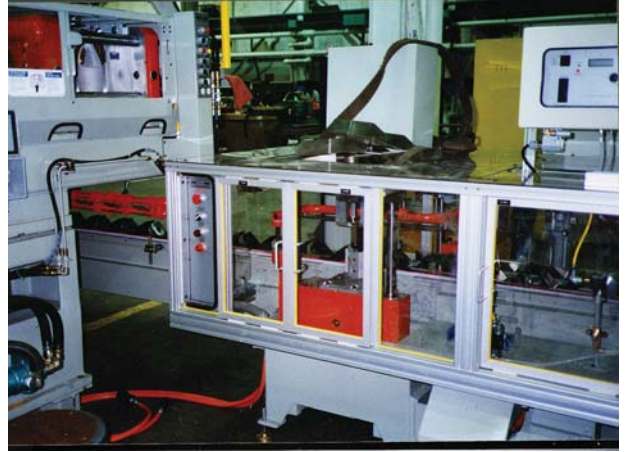



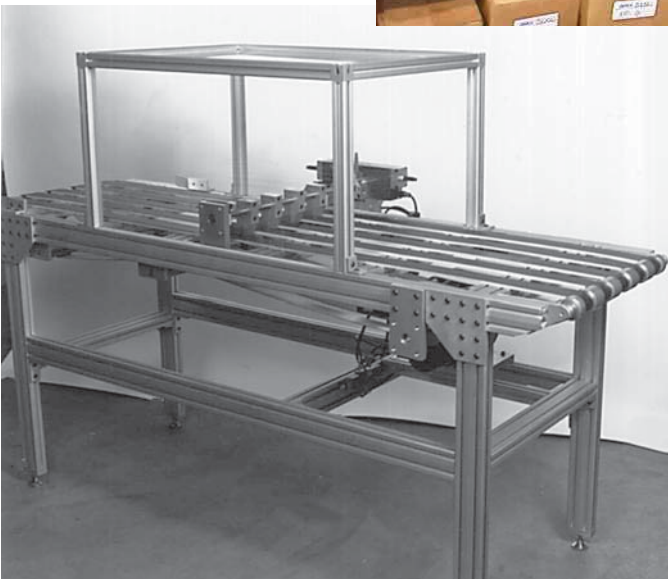

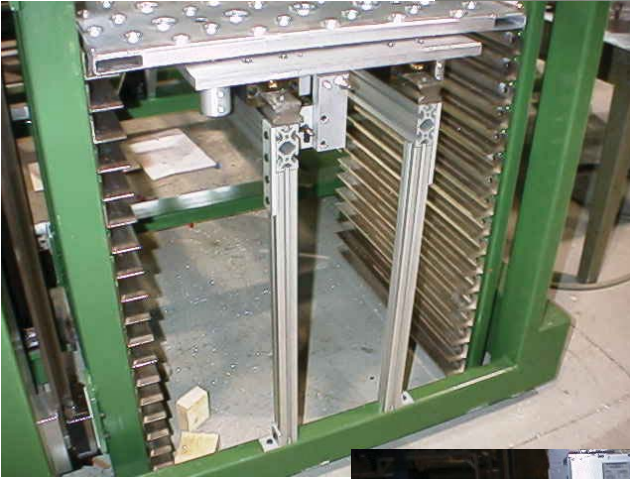

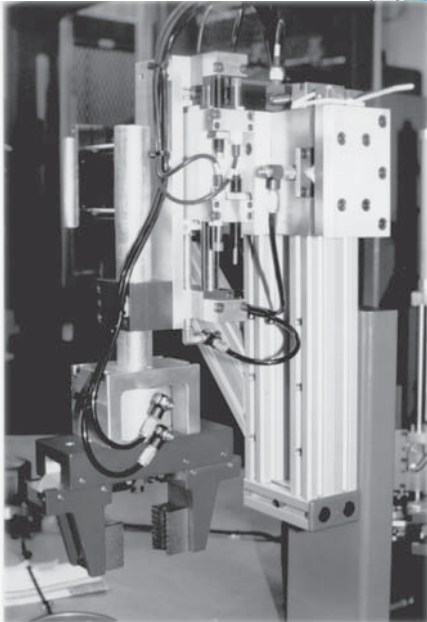
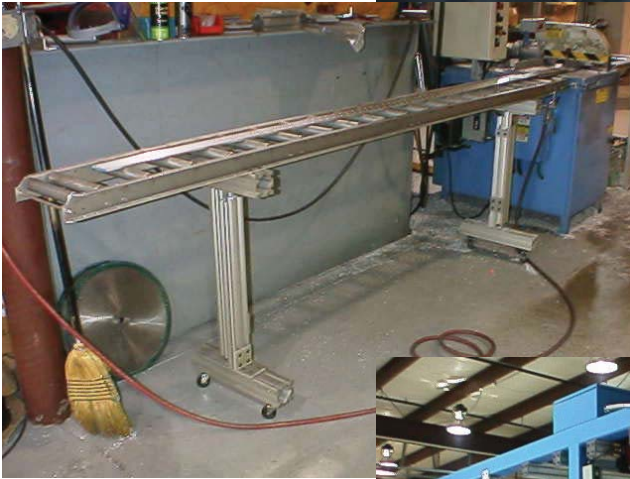



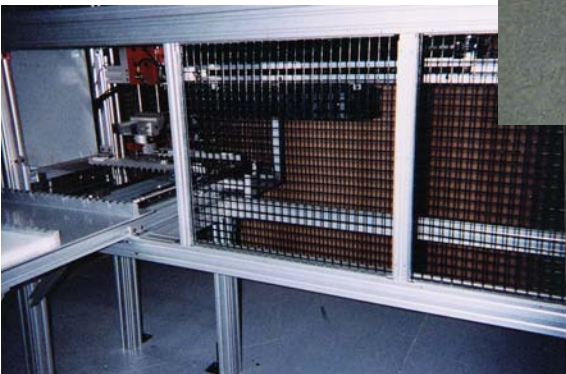

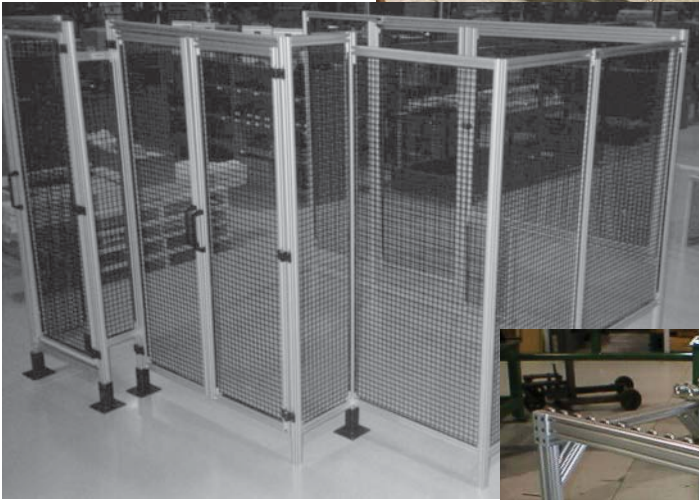
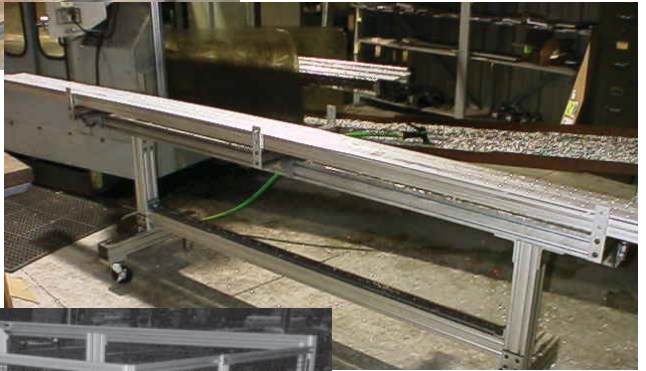

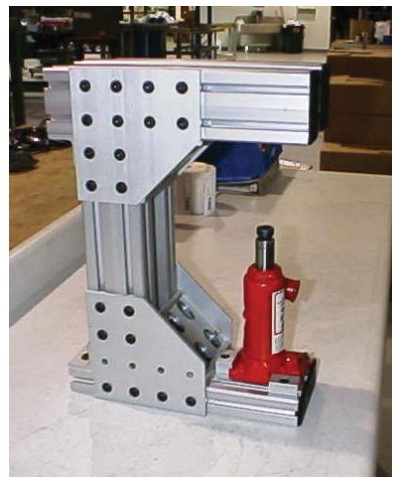
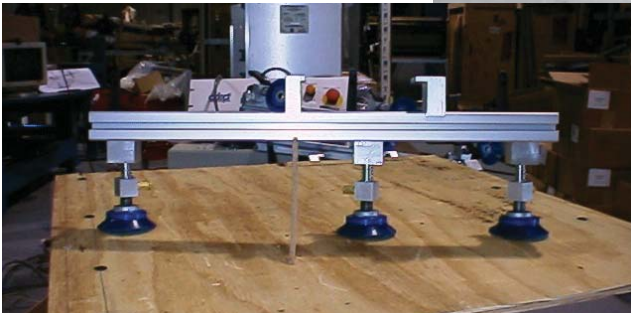
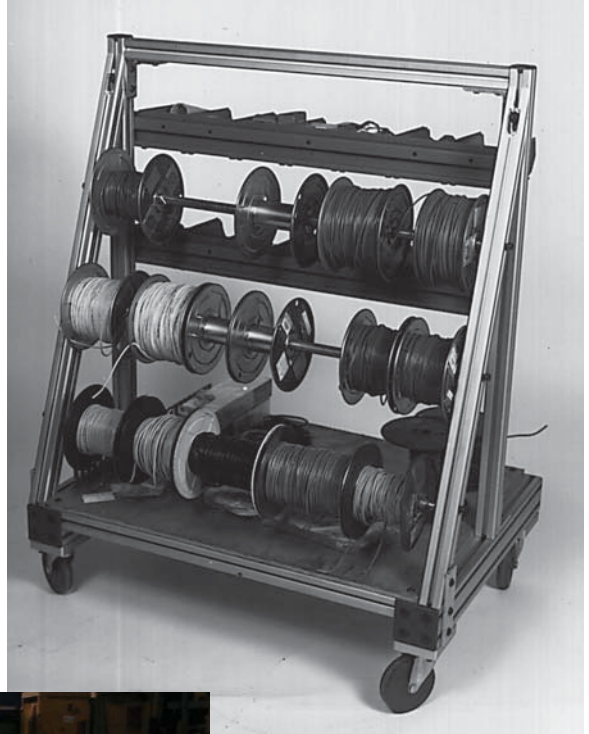





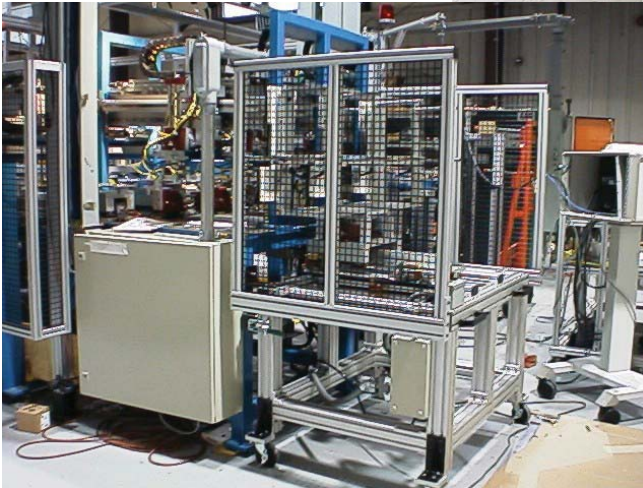

11-1	Corner Angle.....	351	11-52	Deluxe Leg.....	433
11-2	Corner Angle.....	352	11-53	Transition Corner Angle.....	365
11-3	Corner Angle.....	353	11-54	Transition Corner Angle.....	367
11-4	Corner Angle.....	354	11-55	Caster Mounting Plate.....	431
11-5	Transition Corner Angle.....	366	11-56	Castle Corner.....	394
11-6	Corner Angle.....	355	11-57	Castle Corner.....	395
11-7-SP	Extrusion Gusset.....	379	11-58	Castle Corner.....	396
11-7	Extrusion Gusset.....	379	11-60	Steel Angle Bracket.....	382
11-8	Double Steel Corner Bracket.....	381	11-61	Welded Steel Angle Bracket - Left Hand.....	384
11-9	Adjustable Corner Post.....	399	11-62	Welded Steel Angle Bracket - Right Hand.....	384
11-10	Adjustable Corner Post.....	398	11-63	Welded Steel Angle Bracket.....	386
11-11	Adjustable Corner Post Arm.....	397	11-64	Steel Angle Bracket.....	383
11-12-SP	Extrusion Gusset.....	380	11-65	Steel Angle Bracket.....	385
11-12	Extrusion Gusset.....	380	11-66A	Leveling Anchor Plate.....	425
11-13	Corner Angle.....	357	11-66B	Leveling Anchor Plate.....	425
11-14	Corner Angle.....	358	11-70	Steel Flanged Foot.....	434
11-15	Corner Angle.....	359	11-71	Steel Flanged Foot.....	435
11-16	Slotted Corner Angle.....	360	11-72	Steel Flanged Foot.....	436
11-17	Corner Angle.....	362	11-73	Economy Aluminum Floor Mount.....	437
11-19	Corner Angle.....	363	11-74	Economy Aluminum Floor Mount.....	438
11-20	Joining Plate.....	412	11-80	Corner Angle.....	356
11-21	Joining Plate.....	416	11-81	Corner Angle.....	361
11-22	Joining Plate.....	407	11-91LH	Single Mount Linear Bearing with Locking Handle.....	480
11-23	Joining Plate.....	406	11-91	Single Mount Linear Bearing.....	479
11-24	3-way Castle Corner.....	393	11-92LH	Double Mount Linear Bearing with Locking Handle.....	484
11-25	Joining Plate.....	414	11-92	Double Mount Linear Bearing.....	483
11-26	Joining Plate.....	418	11-93LH	Single Mount Linear Bearing with Locking Handle.....	482
11-27	Joining Plate.....	410	11-93	Single Mount Linear Bearing.....	481
11-28	Joining Plate.....	409	11-94LH	Single Mount Linear Bearing with Locking Handle.....	486
11-29	Corner Gusset.....	376	11-94	Single Mount Linear Bearing.....	485
11-30	Wire Mesh Bracket (Steel).....	439	11-95LH	Double Mount Linear Bearing with Locking Handle.....	488
11-31	Wire Mesh Retaining Strip (Rubber)....	440	11-95	Double Mount Linear Bearing.....	487
11-32	Upper Door Slide (3 track).....	441	11-96	Slider Bracket.....	472
11-33	Lower Door Slide (3 track).....	441	11-97	Plastic Slider.....	471
11-34	Corner Gusset.....	377	11-98	Slider Assembly.....	470
11-35	Adjustable Leg.....	433	11-99	Slider Assembly.....	470
11-36	Adjustable Leg.....	433	11-100	Pressure Manifold Plate.....	514
11-37	Corner Angle.....	364	11-101	Pressure Manifold Plate.....	515
11-38	Joining Plate.....	405	11-102	Pressure Manifold Plate.....	515
11-39	Joining Plate.....	408	11-103	Angle Block.....	378
11-40	Joining Plate.....	420	11-104	Angle Block.....	378
11-41	Joining Plate.....	411	11-105	Pivoting Post Arm with Bushing.....	400
11-42	Joining Plate.....	413	11-106	Adjustable Post Angle.....	401
11-43	Joining Plate.....	417	11-107	Pivoting Post Angle with Bushing.....	402
11-44	Joining Plate.....	415	11-108	Pivoting Corner Post.....	403
11-45A	Leveling Plate.....	421	11-109	Pivoting Corner Post.....	404
11-45B	Leveling Plate.....	421	11-110	Swivel Plate Caster w/brake.....	428
11-46A	Leveling Plate.....	423	11-111	Swivel Plate Caster w/brake.....	428
11-46B	Leveling Plate.....	423	11-112	Swivel Plate Caster w/brake.....	428
11-47A	Leveling Anchor Plate.....	424	11-120	Fixed Plate Caster.....	429
11-47B	Leveling Anchor Plate.....	424			
11-48A	Leveling Anchor Plate.....	422			
11-48B	Leveling Anchor Plate.....	422			
11-49A	Leveling Plate.....	426			
11-49B	Leveling Plate.....	426			
11-50	Caster Plate.....	430			
11-51	Joining Plate.....	419			

11-121	Fixed Plate Caster .....	429	11-234K	Zinc Plated Button Head Cap Screw ....	501
11-122	Fixed Plate Caster .....	429	11-234	Button Head Cap Screw .....	497
11-150	Drill Fixture .....	518	11-235	Button Head Cap Screw .....	497
11-151	Drill Fixture .....	518	11-239	Economy T-Nut (Offset Thread) .....	503
11-160	Corner Gusset.....	368	11-240L	Locking Washer .....	511
11-161	Corner Gusset.....	369	11-240S	Washer (Zinc Plated) .....	511
11-162	Corner Gusset.....	370	11-240SS	Washer (Stainless Steel).....	511
11-163	Corner Gusset.....	371	11-240	Washer Hardened Steel Heavy Duty ....	511
11-170	Corner Gusset.....	372	11-241M	Hex Nut.....	511
11-171	Corner Gusset.....	373	11-241	Hex Nut.....	511
11-172	Corner Gusset.....	374	11-242M	Anchor Fastener .....	387
11-173	Corner Gusset.....	375	11-242P	Anchor Fastener .....	387
11-190	Hanger Clip.....	516	11-242	Anchor Fastener .....	387
11-201	Pivot T-Nut with Rubber Bumper.....	506	11-243M	Anchor Butt Fastener .....	389
11-202	Pivot T-Nut with Rubber Bumper.....	506	11-243	Anchor Butt Fastener .....	389
11-203	Pivot T-Nut with Rubber Bumper.....	506	11-244	T-Slot Cover.....	442
11-205	Heavy Duty T-Nut.....	508	11-245	T-Slot Cover.....	442
11-206	Heavy Duty T-Nut.....	508	11-246	T-Slot Cover.....	442
11-207	Heavy Duty T-Nut.....	508	11-247	T-Slot Cover.....	442
11-208	Heavy Duty T-Nut.....	508	11-248M	Double Anchor Fastener .....	388
11-209	Heavy Duty T-Nut.....	508	11-248	Double Anchor Fastener .....	388
11-210	Economy T-Nut (Offset Thread) .....	503	11-249M	Double Anchor Fastener .....	388
11-211	Economy T-Nut (Offset Thread) .....	503	11-249	Double Anchor Fastener .....	388
11-212	Economy T-Nut (Offset Thread) .....	503	11-250	Plastic End Plate.....	512
11-213	Economy T-Nut (Offset Thread) .....	503	11-251	Push Lock Fastener .....	513
11-214	Economy T-Nut (Offset Thread) .....	503	11-252	Aluminum Hinge.....	450
11-215	Economy T-Nut (Centered Thread) .....	504	11-253	Steel Lift-Off Hinge (left hand).....	454
11-215SS	Economy T-Nut (Stainless Steel) .....	504	11-254	Steel Lift-Off Hinge (right hand) .....	454
11-216	Economy T-Nut (Centered Thread) .....	504	11-255	Plastic Hinge.....	455
11-217	Economy T-nut .....	289	11-256	Plastic Handle.....	463
11-217	Long Economy T-nut .....	292	11-257	Plastic End Plate.....	512
11-217	Economy T-Nut (Centered Thread) .....	504	11-258	Plastic End Plate.....	512
11-218B	Blank Continuous T-nut .....	510	11-259	Plastic End Plate.....	512
11-218	Continuous T-nut .....	509	11-260	Panel Mounting Bracket.....	446
11-219	Long Economy T-nut .....	292	11-261	Internal Corner Bracket.....	448
11-219	Economy T-Nut (Centered Thread) .....	504	11-262SS	Universal Connector .....	390
11-220K	Zinc Plated Socket Head Cap Screw ....	501	11-262	Universal Connector .....	390
11-220	Socket Head Cap Screw.....	499	11-263	Heavy Duty Magnetic Door Latch Assembly .....	469
11-221K	Zinc Plated Socket Head Cap Screw ....	501	11-264	Single Door Mechanical Latch .....	466
11-221	Socket Head Cap Screw.....	499	11-265	Double Door Mechanical Latch .....	466
11-222K	Zinc Plated Socket Head Cap Screw ....	501	11-266	T-slot Roller.....	478
11-222	Socket Head Cap Screw.....	499	11-267SS	Universal Panel Connector.....	390
11-223K	Zinc Plated Socket Head Cap Screw ....	501	11-267	Universal Panel Connector.....	390
11-223	Socket Head Cap Screw.....	499	11-268	Universal Connector .....	391
11-224K	Zinc Plated Socket Head Cap Screw ....	501	11-269	Universal Connector .....	392
11-224	Socket Head Cap Screw.....	499	11-270	Threaded Stem Caster Bracket (Steel) .	432
11-225	Socket Head Cap Screw.....	499	11-272	Deluxe Dead Bolt Latch.....	467
11-226	Socket Head Cap Screw.....	499	11-273	Deadbolt Latch .....	468
11-227	Pivot T-Nut with Rubber Bumper.....	506	11-275	Panel Mounting Bracket.....	447
11-230K	Zinc Plated Button Head Cap Screw ....	501	11-277	Plastic End Plate.....	512
11-230	Button Head Cap Screw .....	497	11-279	Steel Slotted Hinge .....	453
11-231K	Zinc Plated Button Head Cap Screw ....	501	11-280	Aluminum Transition Hinge .....	456
11-231	Button Head Cap Screw .....	497	11-282	Mechanical Latch 1/4" slots .....	464
11-232K	Zinc Plated Button Head Cap Screw ....	501	11-283	Transition Mechanical Latch .....	465
11-232	Button Head Cap Screw .....	497	11-285	Hidden Steel Hinge .....	452
11-233K	Zinc Plated Button Head Cap Screw ....	501	11-287	Steel Hinge .....	451
11-233	Button Head Cap Screw .....	497			



11-288	Door Roller Block .....	477	11-456-.50	Stainless Steel Button Head Cap Screw .....	497
11-289	Door Roller Block .....	477	11-456-.63	Stainless Steel Button Head Cap Screw .....	497
11-290	Offset Bearing Block (Plastic) .....	474	11-456-.75	Stainless Steel Button Head Cap Screw .....	497
11-291	Bearing Block (Plastic) .....	475	11-458-.38	Zinc Plated Hex Cap Screw .....	502
11-293	Offset Bearing Block (Plastic) .....	476	11-458-.50	Zinc Plated Hex Cap Screw .....	502
11-295	Plastic Panel Retaining Gasket.....	443	11-458-.63	Zinc Plated Hex Cap Screw .....	502
11-296	Thin Panel Gasket .....	445	11-458-.75	Zinc Plated Hex Cap Screw .....	502
11-298	Plastic Panel Retaining Gasket.....	444	11-458-1.00	Zinc Plated Hex Cap Screw .....	502
11-299	Plastic Panel Retaining Gasket.....	444	11-458-1.25	Zinc Plated Hex Cap Screw .....	502
11-302	Blank Bearing Pad UHMW .....	473	11-458M-12	Zinc Plated Hex Cap Screw .....	502
11-310	Bi-fold Door Pad .....	449	11-458M-16	Zinc Plated Hex Cap Screw .....	502
11-320	Extrusion Molding .....	517	11-458M-20	Zinc Plated Hex Cap Screw .....	502
11-340	Pivot T-nut with Set Screw .....	507	11-458M-25	Zinc Plated Hex Cap Screw .....	502
11-341	Pivot T-nut with Set Screw .....	507	11-458M-30	Zinc Plated Hex Cap Screw .....	502
11-342	Pivot T-nut with Set Screw .....	507	11-500	Single Shaft Base.....	489
11-350	Flanged Button Head Cap Screw.....	498	11-501	Single Shaft Base.....	489
11-351	Flanged Button Head Cap Screw.....	498	11-502	Double Shaft Base .....	490
11-352	Flanged Button Head Cap Screw.....	498	11-503	Double Shaft Base .....	490
11-360	Double Economy T-nut .....	505	11-504	Single Shaft Mounting Base .....	491
11-400	Heavy Duty Hinge .....	457	11-505	Single Shaft Mounting Base .....	491
11-402L	Left Hand Lift-Off Hinge.....	458	11-506	Double Shaft Mounting Base .....	492
11-402S	Left Hand Lift-Off Hinge.....	458	11-507	Double Shaft Mounting Base .....	492
11-402	Left Hand Lift-Off Hinge.....	458	11-508	Double Shaft Mounting Block.....	493
11-403L	Right Hand Lift-Off Hinge .....	459	11-509	Double Shaft Mounting Block.....	493
11-403S	Right Hand Lift-Off Hinge .....	459	11-510	Single Shaft Mounting Block .....	494
11-403	Right Hand Lift-Off Hinge .....	459	11-511	Single Shaft Mounting Block .....	494
11-450-25	Metric Socket Head Cap Screw.....	500	11-512	Single Horizontal Base.....	495
11-450-20	Metric Socket Head Cap Screw.....	500	11-513	Single Horizontal Base.....	495
11-450-16	Metric Socket Head Cap Screw.....	500	C2-XXXX-X	FastFrame Cart .....	20
11-450-12	Metric Socket Head Cap Screw.....	500	D-XXXX-XX-X	FastFrame Door .....	18
11-450-10	Metric Socket Head Cap Screw.....	500	EAL-1	Adjustable Leg (Economy).....	162
11-450K-10	Zinc Plated Socket Head Cap Screw .....	501	EAL-2	Adjustable Leg (Economy).....	162
11-450K-12	Zinc Plated Socket Head Cap Screw .....	501	EAL-3	Adjustable Swivel Leg .....	165
11-450K-16	Zinc Plated Socket Head Cap Screw .....	501	EAL-4	Adjustable Swivel Leg .....	165
11-450K-20	Zinc Plated Socket Head Cap Screw .....	501	EAL-5	Adjustable Swivel Leg.....	165
11-450K-25	Zinc Plated Socket Head Cap Screw .....	501	EAL-6	Adjustable Swivel Leg.....	165
11-452-.1.0	Stainless Steel Socket Head Cap Screw .....	500	EAL-7	Adjustable Leg (cushioned) .....	166
11-452-.5	Stainless Steel Socket Head Cap Screw .....	500	EAL-8	Adjustable Leg (cushioned) .....	166
11-452-.63	Stainless Steel Socket Head Cap Screw .....	500	EAL-9	Adjustable Leg (cushioned) .....	166
11-452-.75	Stainless Steel Socket Head Cap Screw .....	500	EAL-10	Adjustable Swivel Leg .....	165
11-454-25	Metric Button Head Cap Screw .....	498	EAL-E1	Adjustable Leg (Economy).....	163
11-454-20	Metric Button Head Cap Screw .....	498	EAL-E2	Adjustable Leg (Economy).....	163
11-454-16	Metric Button Head Cap Screw .....	498	EAL-E3	Adjustable Leg (Economy).....	164
11-454-12	Metric Button Head Cap Screw .....	498	EB-1	Corner Angle.....	56
11-454-10	Metric Button Head Cap Screw .....	498	EB-2	Corner Angle.....	57
11-454K-10	Zinc Plated Button Head Cap Screw .....	501	EB-3	Corner Angle.....	58
11-454K-12	Zinc Plated Button Head Cap Screw .....	501	EB-4	Corner Angle.....	59
11-454K-16	Zinc Plated Button Head Cap Screw .....	501	EB-5	Panel Mounting Angle .....	193
11-454K-20	Zinc Plated Button Head Cap Screw .....	501	EB-6	1.5 x 1.5 Extrusion Corner Gusset.....	82
11-454K-25	Zinc Plated Button Head Cap Screw .....	501	EB-7SP	1.5 x 1.5 Extrusion Corner Gusset.....	83
11-456-38	Stainless Steel Button Head Cap Screw .....	497	EB-7	1.5 x 1.5 Extrusion Corner Gusset.....	83
			EB-8	1.5 x 3.0 Extrusion Corner Gusset.....	87
			EB-9SP	1.5 x 3.0 Extrusion Corner Gusset.....	88
			EB-9	1.5 x 3.0 Extrusion Corner Gusset.....	88

EB-10A	Cast Corner Gusset.....	89	EB-50	Castle Corner.....	115
EB-10	Cast Corner Gusset.....	89	EB-51	Castle Corner.....	116
EB-11	Cast Corner Gusset.....	90	EB-52	Castle Corner 1.5 x 1.5 Profiles .....	111
EB-12	Cast Corner Gusset.....	91	EB-53	Castle Corner 1.5 x 1.5 Profiles .....	113
EB-13LH	Pivot Joint with Locking Handle .....	119	EB-54	Castle Corner 1.5 x 1.5 Profiles .....	114
EB-13P	Pivoting Hinge.....	118	EB-55	Corner Angle.....	62
EB-13	Adjustable Joint Connector.....	117	EB-56	Corner Angle.....	63
EB-14G	Steel Welded Corner Angle .....	97	EB-57	Corner Angle.....	72
EB-14P	Steel Corner Angle.....	96	EB-58	Corner Gusset.....	73
EB-15AL	Economy Aluminum Floor Mount .....	175	EB-59	Corner Angle.....	60
EB-15AL3	Economy Aluminum Floor Mount .....	176	EB-60	Corner Angle.....	61
EB-15LH	Steel Welded Corner Angle .....	95	EB-61	Double Panel Bracket.....	191
EB-15P	Steel Corner Angle.....	94	EB-62	Panel Bracket.....	192
EB-15RH	Steel Welded Corner Angle .....	95	EB-63	Wire Mesh Bracket .....	186
EB-16	Steel Welded Corner Angle .....	93	EB-64	Double Wire Mesh Bracket .....	187
EB-17-FT	Floor Mounting Bracket .....	177	EB-65	Pivoting Post Arm with Bushing .....	124
EB-17	Steel Double Angle Bracket.....	92	EB-66	Adjustable Post Angle.....	123
EB-20	Corner Gusset.....	86	EB-67	Pivoting Post Angle with Bushing.....	125
EB-22	Joining Plate.....	138	EB-68	Pivoting Corner Post .....	126
EB-23	Joining Plate.....	143	EB-69	Pivoting Corner Post .....	127
EB-24	Joining Plate.....	146	EB-70	Adjustable Leveling Foot.....	178
EB-25	Corner Angle.....	71	EB-71	Joining Plate.....	139
EB-26	Joining Plate.....	133	EB-73	Joining Plate.....	142
EB-27	Joining Plate.....	141	EB-74	Joining Plate.....	144
EB-28	Joining Plate.....	130	EB-76	Joining Plate.....	147
EB-29	Joining Plate.....	131	EB-77	45° Joining Plate .....	149
EB-30	Corner Angle.....	70	EB-78	Joining Plate.....	148
EB-31	Joining Plate.....	129	EB-79	Joining Plate.....	137
EB-32	Joining Plate.....	132	EB-80	Panel Mounting Angle .....	194
EB-33S	Joining Plate.....	128	EB-81	Economy Corner Panel Angle .....	68
EB-33	Joining Plate.....	128	EB-82	Economy Corner Panel Angle .....	69
EB-34	Joining Plate.....	140	EB-83	Joining Plate.....	134
EB-35	Door Stop Bracket .....	236	EB-84	Joining Plate.....	135
EB-36	Angle Blocks.....	84	EB-85	Joining Plate.....	136
EB-37	Angle Blocks.....	84	EB-86	Castle Corner 1.5 x 1.5 Profiles .....	112
EB-38-2	Wire Mesh.....	182	EB-87	Joining Plate.....	145
EB-38-1	Wire Mesh.....	182	EB-88A	1/4 Turn Panel Bracket.....	190
EB-38-1/2	Wire Mesh.....	182	EB-88B	1/4 Turn Panel Bracket.....	190
EB-38-1/2Y	Wire Mesh.....	182	EB-88C	1/4 Turn Panel Bracket.....	190
EB-38-1Y	Wire Mesh.....	182	EB-91LH	Single Mount Linear Bearing with Locking Handle .....	256
EB-38G	Wire Mesh Retaining Strip.....	183	EB-91	Single Mount Linear Bearing .....	255
EB-39A	Wire Mesh Bracket .....	184	EB-92LH	Double Mount Linear Bearing with Locking Handle .....	260
EB-39B	Wire Mesh Bracket .....	184	EB-92	Double Mount Linear Bearing .....	259
EB-40A	Plastic Panel Retaining Gasket.....	199	EB-93LH	Single Mount Linear Bearing with Locking Handle .....	258
EB-40B	Plastic Panel Retaining Gasket.....	200	EB-93	Single Mount Linear Bearing .....	257
EB-40C	Plastic Panel Retaining Gasket.....	199	EB-94LH	Single Mount Linear Bearing with Locking Handle .....	262
EB-40	Plastic Panel Retaining Gasket.....	198	EB-94	Single Mount Linear Bearing .....	261
EB-41	Steel Flanged Foot .....	179	EB-95LH	Double Mount Linear Bearing with Locking Handle .....	264
EB-42	Steel Flanged Foot .....	180	EB-95	Double Mount Linear Bearing .....	263
EB-43	Steel Flanged Foot .....	181	EB-96	Wire Mesh Bracket .....	188
EB-44	Corner Gusset.....	85	EB-100	Corner Angle.....	64
EB-45	Thin Panel Gasket.....	201	EB-101	Corner Angle.....	65
EB-46	Adjustable Corner Post.....	120			
EB-47	Adjustable Corner Post.....	121			
EB-48	Adjustable Arm Post.....	122			
EB-49B	Wire Mesh Bracket .....	185			
EB-49Y	Wire Mesh Bracket .....	185			

EB-102	Slotted Corner Angle .....	66	EB-186	Plastic Panel .....	189
EB-103	Slotted Corner Angle .....	67	EB-187	Plastic Panel .....	189
EB-110	Safety Switch Bracket.....	308	EB-188	Plastic Panel .....	189
EB-111	Corner Gusset.....	74	EB-189	Plastic Panel .....	189
EB-112	Corner Gusset.....	75	EB-190	Plastic Panel .....	189
EB-113	Corner Gusset.....	76	EB-191	Plastic Panel .....	189
EB-114	Corner Gusset.....	77	EB-192	Plastic Panel .....	189
EB-121	Corner Gusset.....	78	EB-193	Plastic Panel .....	189
EB-122	Corner Gusset.....	79	EB-194	Plastic Panel .....	189
EB-123	Corner Gusset.....	80	EB-195	Plastic Panel .....	189
EB-124	Corner Gusset.....	81	EB-196	Plastic Panel .....	189
EB-125	30° Joining Plate .....	150	EB-197	Plastic Panel .....	189
EB-126	60° Joining Plate .....	151	EB-198	Plastic Panel .....	189
EB-127	45° Joining Plate .....	152	EB-200	Single Shaft Base.....	266
EB-128	60° Joining Plate .....	153	EB-201	Single Shaft Base.....	266
EB-129	30° Joining Plate .....	154	EB-202	Double Shaft Base .....	267
EB-130	Heavy Duty Hinge Assembly.....	219	EB-203	Double Shaft Base .....	267
EB-132L	Left Hand Lift-Off Hinge - 5/16" slots... 220		EB-204	Single Shaft Mounting Plate .....	268
EB-132S	Left Hand Lift-Off Hinge - 5/16" slots... 220		EB-205	Single Shaft Mounting Plate .....	268
EB-132	Left Hand Lift-Off Hinge - 5/16" slots... 220		EB-206	Double Shaft Mounting Plate.....	269
EB-133L	Right Hand Lift-Off Hinge - 5/16" slots .....	221	EB-207	Double Shaft Mounting Plate.....	269
EB-133S	Right Hand Lift-Off Hinge - 5/16" slots .....	221	EB-208	Cross Clamp .....	270
EB-133	Right Hand Lift-Off Hinge - 5/16" slots .....	221	EB-209	Cross Clamp .....	270
EB-140	Heavy Duty Transition 5/16 - 1/4 slots Hinge Assembly.....	222	EB-210	Single Shaft Mounting Block .....	271
EB-142L	Left Hand Transition Lift-Off Hinge 5/16 - 1/4 slots.....	223	EB-211	Single Shaft Mounting Block .....	271
EB-142S	Left Hand Transition Lift-Off Hinge 5/16 - 1/4 slots.....	223	EB-212	Double Shaft Mounting Block.....	272
EB-142	Left Hand Transition Lift-Off Hinge 5/16 - 1/4 slots.....	223	EB-213	Double Shaft Mounting Block.....	272
EB-143L	Right Hand Transition Lift-Off Hinge 5/16 - 1/4 slots .....	224	EB-214	Single Horizontal Base.....	273
EB-143S	Right Hand Transition Lift-Off Hinge 5/16 - 1/4 slots.....	224	EB-215	Single Horizontal Base.....	273
EB-143	Right Hand Transition Lift-Off Hinge 5/16 - 1/4 slots.....	224	EB-216	Single Horizontal Base.....	274
EB-151	Floor Locks.....	174	EB-217	Single Horizontal Base.....	274
EB-153	Floor Locks.....	174	EB-218	Stanchion Shafts .....	275
EB-154	Floor Lock Mounting Plate.....	161	EB-219	Stanchion Shafts .....	275
EB-160	Plastic Panel .....	189	EBP-1A	Leveling Plate .....	155
EB-161	Plastic Panel .....	189	EBP-1B	Leveling Plate .....	155
EB-162	Plastic Panel .....	189	EBP-1C	Leveling Plate .....	155
EB-165	Plastic Panel .....	189	EBP-1	Leveling Plate .....	155
EB-166	Plastic Panel .....	189	EBP-2A	Leveling Plate .....	156
EB-170	Plastic Panel .....	189	EBP-2B	Leveling Plate .....	156
EB-171	Plastic Panel .....	189	EBP-2C	Leveling Plate .....	156
EB-172	Plastic Panel .....	189	EBP-2	Leveling Plate .....	156
EB-175	Plastic Panel .....	189	EBP-3A	Leveling Plate .....	157
EB-176	Plastic Panel .....	189	EBP-3B	Leveling Plate .....	157
EB-177	Plastic Panel .....	189	EBP-3C	Leveling Plate .....	157
EB-180	Plastic Panel .....	189	EBP-3	Leveling Plate .....	157
EB-181	Plastic Panel .....	189	EBP-4A	Leveling Plate .....	158
EB-185	Plastic Panel .....	189	EBP-4B	Leveling Plate .....	158
			EBP-4C	Leveling Plate .....	158
			EBP-4	Leveling Plate .....	158
			EBP-5A	Caster Mounting Plate .....	173
			EBP-5	Caster Mounting Plate .....	172
			EBP-6A	Leveling Plate .....	159
			EBP-6B	Leveling Plate .....	159
			EBP-6C	Leveling Plate .....	159
			EBP-6	Leveling Plate .....	159
			EBP-8	Leveling Anchor Plate.....	160
			EC-3F	Fixed Plate Caster .....	168

EC-3S	Swivel Plate Caster w/brake.....	169	EF-11SS-.75	Stainless Steel Socket Head Cap Screw .....	278
EC-4F	Fixed Plate Caster .....	168	EF-11SS-1.0	Stainless Steel Socket Head Cap Screw .....	278
EC-4S	Swivel Plate Caster w/brake.....	169	EF-11SS-1.25	Stainless Steel Socket Head Cap Screw .....	278
EC-5F	Fixed Plate Caster .....	168	EF-12-.50	Button Head Cap Screw .....	280
EC-5S	Swivel Plate Caster w/brake.....	169	EF-12-.63	Button Head Cap Screw .....	280
ECC	Castle Corner.....	109	EF-12-.75	Button Head Cap Screw .....	280
ECC-A	3-way Castle Corner .....	110	EF-12-.875	Button Head Cap Screw .....	280
EC-S1	Threaded Stem Caster .....	167	EF-12-1.0	Button Head Cap Screw .....	280
EC-S2	Threaded Stem Caster .....	167	EF-12-1.25	Button Head Cap Screw .....	280
EC-S3	Threaded Stem Caster .....	167	EF-12-1.50	Button Head Cap Screw .....	280
ECT-4F	Total Lock Fixed Plate Caster .....	171	EF-12F-.50	Button Head Cap Screw (Flanged) .....	281
ECT-4S	Total Lock Swivel Plate Caster .....	170	EF-12F-.63	Button Head Cap Screw (Flanged) .....	281
EF-1	Pivot T-nut with Rubber Bumper .....	286	EF-12F-.75	Button Head Cap Screw (Flanged) .....	281
EF-2A	Economy T-nut .....	289	EF-12F-1.0	Button Head Cap Screw (Flanged) .....	281
EF-2AST	Stainless Steel Economy T-nut .....	290	EF-12K-.50	Zinc Plated Button Head Cap Screw ....	279
EF-2B	Economy T-nut .....	289	EF-12K-.63	Zinc Plated Button Head Cap Screw ....	279
EF-2C	Economy T-nut .....	289	EF-12K-.75	Zinc Plated Button Head Cap Screw ....	279
EF-2CST	Stainless Steel Economy T-nut .....	290	EF-12K-.875	Zinc Plated Button Head Cap Screw ....	279
EF-2D	Double Thread Economy T-nut .....	293	EF-12K-1.0	Zinc Plated Button Head Cap Screw ....	279
EF-2E	Economy T-nut .....	289	EF-12K-1.25	Zinc Plated Button Head Cap Screw ....	279
EF-2H	Economy T-nut .....	289	EF-12K-1.50	Zinc Plated Button Head Cap Screw ....	279
EF-2ST	Stainless Steel Economy T-nut .....	290	EF-12M-12	Button Head Cap Screw .....	280
EF-2	Economy T-nut .....	289	EF-12M-16	Button Head Cap Screw .....	280
EF-4A	Long Economy T-nut .....	292	EF-12M-20	Button Head Cap Screw .....	280
EF-4B	Long Economy T-nut .....	292	EF-12M-25	Button Head Cap Screw .....	280
EF-4C	Long Economy T-nut .....	292	EF-12M-30	Button Head Cap Screw .....	280
EF-4D	Long Economy T-nut .....	292	EF-12M-35	Button Head Cap Screw .....	280
EF-4	Long Economy T-nut .....	292	EF-12MK-12	Zinc Plated Button Head Cap Screw ....	279
EF-9	5/16-18 Turn Lock T-Bolt.....	283	EF-12MK-16	Zinc Plated Button Head Cap Screw ....	279
EF-10	T-Bolt.....	284	EF-12MK-20	Zinc Plated Button Head Cap Screw ....	279
EF-11-.5	Socket Head Cap Screw.....	278	EF-12MK-25	Zinc Plated Button Head Cap Screw ....	279
EF-11-.63	Socket Head Cap Screw.....	278	EF-12MK-30	Zinc Plated Button Head Cap Screw ....	279
EF-11-.75	Socket Head Cap Screw.....	278	EF-12MK-35	Zinc Plated Button Head Cap Screw ....	279
EF-11-1.0	Socket Head Cap Screw.....	278	EF-12SS-.50	Stainless Steel Button Head Cap Screw .....	280
EF-11-1.25	Socket Head Cap Screw.....	278	EF-12SS-.63	Stainless Steel Button Head Cap Screw .....	280
EF-11-1.5	Socket Head Cap Screw.....	278	EF-12SS-.75	Stainless Steel Button Head Cap Screw .....	280
EF-11-1.75	Socket Head Cap Screw.....	278	EF-12SS-.875	Stainless Steel Button Head Cap Screw .....	280
EF-11-2.0	Socket Head Cap Screw.....	278	EF-12SS-1.0	Stainless Steel Button Head Cap Screw .....	280
EF-11K-.50	Zinc Plated Socket Head Cap Screw ....	279	EF-12SS-1.25	Stainless Steel Button Head Cap Screw .....	280
EF-11K-.63	Zinc Plated Socket Head Cap Screw ....	279	EF-13A	5/16" Washers and Nuts .....	285
EF-11K-.75	Zinc Plated Socket Head Cap Screw ....	279	EF-13B	5/16" Washers and Nuts .....	285
EF-11K-.875	Zinc Plated Socket Head Cap Screw ....	279	EF-13C	5/16" Washers and Nuts .....	285
EF-11K-1.0	Zinc Plated Socket Head Cap Screw ....	279	EF-13CM	5/16" Washers and Nuts .....	285
EF-11K-1.25	Zinc Plated Socket Head Cap Screw ....	279	EF-13L	5/16" Washers and Nuts .....	285
EF-11K-1.50	Zinc Plated Socket Head Cap Screw ....	279	EF-13S	5/16" Washers and Nuts .....	285
EF-11MK-12	Zinc Plated Socket Head Cap Screw ....	279	EF-14	Push Lock Fastener .....	298
EF-11MK-16	Zinc Plated Socket Head Cap Screw ....	279	EF-15A	Plastic Handle.....	225
EF-11MK-20	Zinc Plated Socket Head Cap Screw ....	279			
EF-11MK-25	Zinc Plated Socket Head Cap Screw ....	279			
EF-11MK-30	Zinc Plated Socket Head Cap Screw ....	279			
EF-11MK-35	Zinc Plated Socket Head Cap Screw ....	279			
EF-11SS-.5	Stainless Steel Socket Head Cap Screw .....	278			
EF-11SS-.63	Stainless Steel Socket Head Cap Screw .....	278			

EF-15B	Plastic Handle.....	225	EF-40B	Deluxe Door Handle.....	232
EF-15C	Plastic Handle.....	225	EF-41A	Chrome Door Handle.....	233
EF-16	Aluminum Handle.....	231	EF-41B	Chrome Door Handle.....	233
EF-17-3	Upper Door Slide Track.....	204	EF-41C	Chrome Door Handle.....	233
EF-18-3	Lower Door Slide Track.....	204	EF-42A	Single Tubing Clamp.....	309
EF-19A	Plastic End Plate.....	299	EF-42B	Single Tubing Clamp.....	309
EF-19B	Plastic End Plate.....	299	EF-42C	Single Tubing Clamp.....	309
EF-19C	Plastic End Plate.....	299	EF-42D	Single Tubing Clamp.....	309
EF-19D	Plastic End Plate.....	299	EF-43A	Double Tubing Clamp.....	310
EF-19E	Plastic End Plate.....	299	EF-43B	Double Tubing Clamp.....	310
EF-19F	Plastic End Plate.....	299	EF-43C	Double Tubing Clamp.....	310
EF-19G	Plastic End Plate.....	299	EF-43D	Double Tubing Clamp.....	310
EF-20	Plastic Hinge.....	212	EF-45B	T-slot Cover or Panel Gasket.....	206
EF-21LH	Steel Lift-Off Hinge.....	215	EF-45G	T-slot Cover or Panel Gasket.....	206
EF-21RH	Steel Lift-Off Hinge.....	215	EF-45SO	T-slot Cover or Panel Gasket.....	206
EF-21	Aluminum Hinge.....	211	EF-45Y	T-slot Cover or Panel Gasket.....	206
EF-22A	Mechanical Door Latch.....	243	EF-48	Offset Extrusion Door Handle.....	226
EF-22HD	Heavy Duty Magnetic Door Latch Assembly.....	240	EF-49	Set Screw Anchor Fastener.....	101
EF-22	Magnetic Door Latch Assembly.....	239	EF-50	Economy T-nut with Set Screw.....	291
EF-23A	T-Slot Cover.....	205	EF-51	Economy T-nut with Set Screw.....	291
EF-23B	T-Slot Cover.....	205	EF-52	Economy T-nut with Set Screw.....	291
EF-23G	T-Slot Cover.....	205	EF-53B	Blank Continuous T-nut.....	296
EF-23SO	T-Slot Cover.....	205	EF-53	Continuous T-nut.....	295
EF-23Y	T-Slot Cover.....	205	EF-55	Heavy Duty T-nut.....	294
EF-24	Mechanical Latch.....	241	EF-56	Heavy Duty T-nut.....	294
EF-25B	Panel Mounting Bracket.....	196	EF-57	Heavy Duty T-nut.....	294
EF-25	Panel Mounting Bracket.....	195	EF-58	Heavy Duty T-nut.....	294
EF-26	Corner Joint and Panel Bracket.....	197	EF-59	Heavy Duty T-nut.....	294
EF-27A	Internal Corner Bracket.....	104	EF-60	Rubber Door Seal.....	203
EF-27	Internal Corner Bracket.....	103	EF-61M	Anchor Butt Fastener.....	100
EF-28	Extrusion Molding.....	306	EF-61SS	Anchor Butt Fastener.....	100
EF-29A	Universal Connector.....	106	EF-61	Anchor Butt Fastener.....	100
EF-29B	Universal Connector.....	107	EF-62M	Anchor Fastener.....	98
EF-29D	Double Universal Connector.....	108	EF-62P	Anchor Fastener.....	98
EF-29	Universal Connector.....	105	EF-62SS	Anchor Fastener.....	98
EF-30A	Clamp Bar.....	307	EF-62	Anchor Fastener.....	98
EF-30B	Clamp Bar.....	307	EF-63M	Double Anchor Fastener.....	99
EF-30C	Clamp Bar.....	307	EF-63SS	Double Anchor Fastener.....	99
EF-32-4	Adjustable Locking Handle (Male).....	234	EF-63	Double Anchor Fastener.....	99
EF-32-3	Adjustable Locking Handle (Male).....	234	EF-64	Double Anchor Fastener.....	99
EF-32-2	Adjustable Locking Handle (Male).....	234	EF-64M	Anchor Butt Fastener.....	99
EF-32-1	Adjustable Locking Handle (Male).....	234	EF-64SS	Anchor Butt Fastener.....	99
EF-33-2	Adjustable Locking Handle (Female).....	235	EF-65	Pivot T-nut with Set Screw.....	287
EF-33-1	Adjustable Locking Handle (Female).....	235	EF-66	Pivot T-nut with Set Screw.....	287
EF-34A	Bearing Block (Plastic).....	244	EF-67	Pivot T-nut with Set Screw.....	287
EF-34B	Bearing Block (Plastic).....	244	EF-68	Pivot T-nut with Set Screw.....	287
EF-35A	Offset Bearing Block (Plastic).....	245	EF-69	Pivot T-nut with Set Screw.....	287
EF-35B	Offset Bearing Block (Plastic).....	245	EF-70	Hidden Steel Hinge.....	216
EF-36	Slider Block Bracket.....	246	EF-72	Steel Hinge.....	213
EF-37A	Plastic Slider.....	247	EF-73	Die Cast Zinc Hinge.....	217
EF-37B	Plastic Slider.....	247	EF-74	Die Cast Zinc Locking Hinge.....	218
EF-38S	Slider Assembly.....	248	EF-75	Steel Slotted Hinge.....	214
EF-38	Slider Assembly.....	248	EF-77	Blank Hanging Slider Track 5/16" Slot Size.....	250
EF-39	Blank Bearing Pad UHMW.....	249	EF-78	Mechanical Door Latch 5/16" Slots.....	242
EF-40A	Deluxe Door Handle.....	232	EF-79	Hanging Slider Track 5/16" Slot Size.....	251

EF-80	Drill Fixture .....	311	EF-157SS-.63	Stainless Steel Flat Head Socket Cap Screw .....	281
EF-81	Drill Fixture .....	311	EF-158-.50	Flat Head Socket Cap Screw .....	281
EF-83	Heavy Duty T-nut .....	294	EF-158-.63	Flat Head Socket Cap Screw .....	281
EF-84	Heavy Duty T-nut .....	294	EF-158SS-.50	Stainless Steel Flat Head Socket Cap Screw .....	281
EF-88	Door Roller Block - 5/16" Slot (lift out)	253	EF-158SS-.63	Stainless Steel Flat Head Socket Cap Screw .....	281
EF-89	Door Roller Block - 5/16" Slot (lift out)	253	EF-160	Conveyor Rollers .....	277
EF-91	Ball and Spring Pivot T-nut .....	288	EF-161	Conveyor Rollers .....	277
EF-92	Ball and Spring Pivot T-nut .....	288	EF-162	Conveyor Rollers .....	277
EF-93	Ball and Spring Pivot T-nut .....	288	EF-163	Conveyor Rollers .....	277
EF-94	Ball and Spring Pivot T-nut .....	288	EF-166	Conveyor Rollers .....	277
EF-95	Ball and Spring Pivot T-nut .....	288	EF-167	Conveyor Rollers .....	277
EF-96	Z-nut .....	297	EF-168	Conveyor Rollers .....	277
EF-100M	Plate Connector .....	102	EF-170	Deluxe Dead Bolt Latch .....	237
EF-100	Plate Connector .....	102	EF-171	Deadbolt Latch .....	238
EF-110	Bi-fold Door Pad .....	208	EF-180	Extruded Door Handle .....	227
EF-111	Bi-fold Door Pad .....	209	EF-181	Extruded Door Handle .....	228
EF-115	Bi-fold Door Pad .....	210	EF-182	Extruded Door Hand Grip .....	229
EF-125	Safety Door Handle .....	230	EF-SS13A	Stainless Steel Washer .....	285
EF-126	Safety Door Handle .....	230	EF-SS29A	Universal Connector .....	106
EF-127	Safety Door Handle .....	230	EF-SS29	Universal Connector .....	105
EF-140	Stiffener for Plastic Panel .....	207	EM-1-EX-45	Standard Machining Service .....	593
EF-141	Stiffener for Plastic Panel .....	207	EM-1	Standard Machining Service .....	593
EF-145	Hanger Clip 5/16" wide slot .....	303	EM-2	Standard Machining Service .....	593
EF-146A	Tool Hanger .....	305	EM-3C	Standard Machining Service .....	595
EF-146	Tool Hanger .....	305	EM-3P	Standard Machining Service .....	600
EF-150	Conveyor Roller Mounting Block .....	276	EM-3	Standard Machining Service .....	595
EF-151	Conveyor Roller Mounting Block .....	276	EM-4L	Standard Machining Service .....	599
EF-155-.50	Zinc Plated Hex Cap Screw .....	282	EM-4N	Standard Machining Service .....	600
EF-155-.63	Zinc Plated Hex Cap Screw .....	282	EM-4S	Standard Machining Service .....	599
EF-155-.75	Zinc Plated Hex Cap Screw .....	282	EM-5	Standard Machining Service .....	596
EF-155-.875	Zinc Plated Hex Cap Screw .....	282	EM-6	Standard Machining Service .....	600
EF-155-1.0	Zinc Plated Hex Cap Screw .....	282	EM-7	Standard Machining Service .....	596
EF-155-1.25	Zinc Plated Hex Cap Screw .....	282	EM-8	Standard Machining Service .....	598
EF-155-1.50	Zinc Plated Hex Cap Screw .....	282	EM-9	Standard Machining Service .....	598
EF-155M-12	Zinc Plated Hex Cap Screw .....	282	EM-10	Standard Machining Service .....	600
EF-155M-16	Zinc Plated Hex Cap Screw .....	282	EM-13	Standard Machining Service .....	599
EF-155M-20	Zinc Plated Hex Cap Screw .....	282	ER	T-slot Roller .....	252
EF-155M-25	Zinc Plated Hex Cap Screw .....	282	ER-BL	Door Roller Block Assembly .....	254
EF-155M-30	Zinc Plated Hex Cap Screw .....	282	ETH	Tool Hanger .....	304
EF-156-.50	Flat Head Socket Cap Screw .....	281	EX-1	Structural Aluminum Extrusion .....	29
EF-156-.63	Flat Head Socket Cap Screw .....	281	EX-2	Structural Aluminum Extrusion .....	30
EF-156-.75	Flat Head Socket Cap Screw .....	281	EX-3	Structural Aluminum Extrusion .....	31
EF-156-.88	Flat Head Socket Cap Screw .....	281	EX-6	Structural Aluminum Extrusion .....	29
EF-156-1.0	Flat Head Socket Cap Screw .....	281	EX-7	SMOOTH-Series Structural Aluminum Extrusion .....	39
EF-156-1.25	Flat Head Socket Cap Screw .....	281	EX-8	SMOOTH-Series Structural Aluminum Extrusion .....	39
EF-156SS-.50	Stainless Steel Flat Head Socket Cap Screw .....	281	EX-9	Structural Aluminum Extrusion .....	30
EF-156SS-.63	Stainless Steel Flat Head Socket Cap Screw .....	281	EX-11	Aluminum Extrusion .....	336
EF-156SS-.75	Stainless Steel Flat Head Socket Cap Screw .....	281	EX-12	Aluminum Extrusion .....	336
EF-157-.50	Flat Head Socket Cap Screw .....	281	EX-13	Aluminum Extrusion .....	337
EF-157-.63	Flat Head Socket Cap Screw .....	281	EX-14	Smooth-Series Aluminum Extrusion ...	338
EF-157-.75	Flat Head Socket Cap Screw .....	281	EX-15ANDZ	Structural Angle Bracket Profile .....	588
EF-157-1.0	Flat Head Socket Cap Screw .....	281	EX-15	Structural Angle Bracket Profile .....	588
EF-157SS-.50	Stainless Steel Flat Head Socket Cap Screw .....	281	EX-16ANDZ	Structural Angle Bracket Profile .....	588

EX-16	Structural Angle Bracket Profile.....	588	MT-MCL-SN	Sensor .....	328
EX-17ANDZ	Structural Angle Bracket Profile.....	589	MT-MCL-SP	Sensor .....	328
EX-17	Structural Angle Bracket Profile.....	589	MT-MFLD-L8	Vacuum or Pneumatic Manifold.....	333
EX-18ANDZ	Structural Angle Bracket Profile.....	589	MT-MFLD-L12	Vacuum or Pneumatic Manifold.....	333
EX-18	Structural Angle Bracket Profile.....	589	MT-MFLD-S8	Vacuum or Pneumatic Manifold.....	333
EX-22	Aluminum Extrusion .....	337	MT-MFLD-S12	Vacuum or Pneumatic Manifold.....	333
EX-24	Aluminum Extrusion .....	338	MT-QCMG-A	Electromagnet Quick Change Module ..	325
EX-26	Structural Aluminum Extrusion .....	32	MT-QCMG-B	Electromagnet Quick Change Module ..	325
EX-30ANDZ	Angle Bracket Profile .....	592	MT-QCPN-A	Pneumatic Quick Change Module .....	326
EX-30	Angle Bracket Profile .....	592	MT-QCPN-B	Pneumatic Quick Change Module .....	326
EX-31ANDZ	Angle Bracket Profile .....	592	MT-SAS	Small Vacuum Assembly Plate .....	322
EX-31	Angle Bracket Profile .....	592	MT-ST-A	Small Vacuum Stem .....	317
EX-32ANDZ	Angle Bracket Profile .....	592	MT-ST-B	Small Vacuum Stem .....	317
EX-32	Angle Bracket Profile .....	592	MT-ST-C	Small Vacuum Stem .....	317
EX-33ANDZ	Angle Bracket Profile .....	592	MT-ST-D	Medium Vacuum Stem .....	318
EX-33	Angle Bracket Profile .....	592	MT-ST-E	Medium Vacuum Stem .....	318
EX-34ANDZ	Structural Angle Bracket Profile.....	590	MT-ST-F	Large Vacuum Stem .....	319
EX-34	Structural Angle Bracket Profile.....	590	MT-ST-G	Large Vacuum Stem .....	319
EX-36	Structural Aluminum Extrusion .....	33	MT-ST-H	Large Vacuum Stem .....	319
EX-37	Structural Aluminum Extrusion .....	32	MT-ST-I	Large Vacuum Stem .....	319
EX-45HD	Structural Aluminum Extrusion .....	34	MT-ST-J	Large Vacuum Stem .....	319
EX-52	SMOOTH-Series Structural Aluminum Extrusion .....	41	MT-ST-K	Large Vacuum Stem .....	319
EX-53	Door Stop .....	591	MT-STL--CL	Large Vacuum Stem Assembly.....	321
EX-54	SMOOTH-Series Structural Aluminum Extrusion .....	42	MT-STL--SP	Large Vacuum Stem Assembly.....	321
EX-56	Door Stop (Light Blocking).....	202	MT-VA-4C	Vacuum Arm.....	320
EX-60	Structural Aluminum Extrusion .....	33	MT-VA-4T	Vacuum Arm.....	320
EX-61	SMOOTH-Series Structural Aluminum Extrusion .....	37	MT-VA-6B	Vacuum Arm.....	320
EX-63	SMOOTH-Series Structural Aluminum Extrusion .....	37	MT-VA-6C	Vacuum Arm.....	320
EX-64	SMOOTH-Series Structural Aluminum Extrusion .....	38	MT-VA-6T	Vacuum Arm.....	320
EX-65	SMOOTH-Series Structural Aluminum Extrusion .....	38	MT-VA-BC	Vacuum Arm.....	320
EX-66	SMOOTH-Series Structural Aluminum Extrusion .....	40	P2-XXXX-XX-X	FastFrame Panel .....	17
EX-67	Structural Aluminum Extrusion .....	31	PM-2B	Pneumatic Manifold End Plate and Gasket .....	300
EX-68	SMOOTH-Series Structural Aluminum Extrusion .....	40	PM-2	Pneumatic Manifold End Plate and Gasket.....	300
EX-69	SMOOTH-Series Structural Aluminum Extrusion .....	41	PM-3B	Pneumatic Manifold End Plate and Gasket.....	301
EX-70	Smooth-Series Aluminum Extrusion ..	339	PM-3	Pneumatic Manifold End Plate and Gasket.....	301
EX-71	Smooth-Series Aluminum Extrusion ..	339	PM-31	Pressure Manifold Plate.....	302
EX-72	Smooth-Series Aluminum Extrusion ..	340	PM-32	Pressure Manifold Plate.....	302
EX-73	Smooth-Series Aluminum Extrusion ..	340	S-XXXX-XX-X	FastFrame Standard Duty Base.....	22
EX-82	SMOOTH-Series Structural Aluminum Extrusion .....	42	VB-5-S	Vacuum Cup .....	313
EX-83	Structural Aluminum Extrusion .....	34	VB-5	Vacuum Cup .....	313
H-XXXX-XX-X	FastFrame Heavy Duty Base.....	22	VB-10-S	Vacuum Cup .....	313
L-XXXX-XX-X	FastFrame Light Duty Base .....	22	VB-10	Vacuum Cup .....	313
MT-LAS	Large Vacuum Assembly Plate .....	324	VB-15-S	Vacuum Cup .....	313
MT-MAS	Medium Vacuum Assembly Plate .....	323	VB-15	Vacuum Cup .....	313
MT-MCA-4C	Mini Clamp Mounting Arm .....	329	VB-20-S	Vacuum Cup .....	313
MT-MCA-6C	Mini Clamp Mounting Arm .....	329	VB-20	Vacuum Cup .....	313
MT-MCL-1	90° Mini Clamp (Standard).....	327	VB-30-S	Vacuum Cup .....	313
MT-MCL-2	90° Mini Clamp (Sensor).....	328	VB-30	Vacuum Cup .....	313
			VB-50-S	Vacuum Cup .....	313
			VB-50	Vacuum Cup .....	313
			VB-75-S	Vacuum Cup .....	313
			VB-75	Vacuum Cup .....	313
			VB-110-S	Vacuum Cup .....	313
			VB-110	Vacuum Cup .....	313

---

VF-20-S	Vacuum Cup .....	315
VF-20	Vacuum Cup .....	315
VF-30-S	Vacuum Cup .....	315
VF-30	Vacuum Cup .....	315
VF-50-S	Vacuum Cup .....	315
VF-50	Vacuum Cup .....	315
VF-75-S	Vacuum Cup .....	315
VF-75	Vacuum Cup .....	315
VF-110-S	Vacuum Cup .....	315
VF-110	Vacuum Cup .....	315
VGEN-1	Vacuum Generator.....	330
VGEN-2	Vacuum Generator.....	331
VMB-20-S	Vacuum Cup .....	314
VMB-20	Vacuum Cup .....	314
VMB-30-S	Vacuum Cup .....	314
VMB-30	Vacuum Cup .....	314
VMB-50-S	Vacuum Cup .....	314
VMB-50	Vacuum Cup .....	314
VOC-35	Vacuum Cup Oval .....	316
VOC-60	Vacuum Cup Oval .....	316
VSW-1	Vacuum Switch.....	332
VU-6-S	Vacuum Cup .....	315
VU-6	Vacuum Cup .....	315
VU-10-S	Vacuum Cup .....	315
VU-10	Vacuum Cup .....	315